

PROJECT **I**MPLEMENTATION **M**ANUAL **IN 2 VOLUMES**

GOVERNMENT OF THE REPUBLIC OF ZAMBIA
MICROPROJECTS UNIT
NATIONAL COMMISSION FOR DEVELOPMENT PLANNING

for use by

PROJECT COMMUNITIES

VOLUME 2



PROJECT IMPLEMENTATION MANUAL IN 2 VOLUMES

GOVERNMENT OF THE REPUBLIC OF ZAMBIA
MICROPROJECTS UNIT
NATIONAL COMMISSION FOR DEVELOPMENT PLANNING

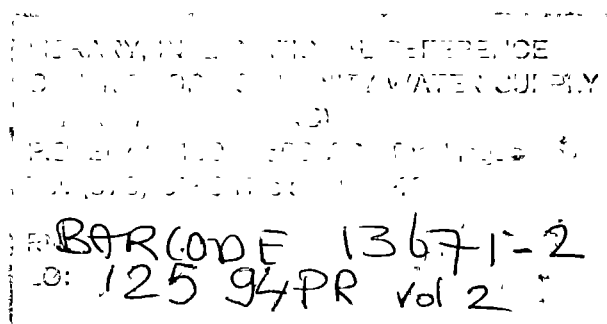

for use by

PROJECT COMMUNITIES

VOLUME 2

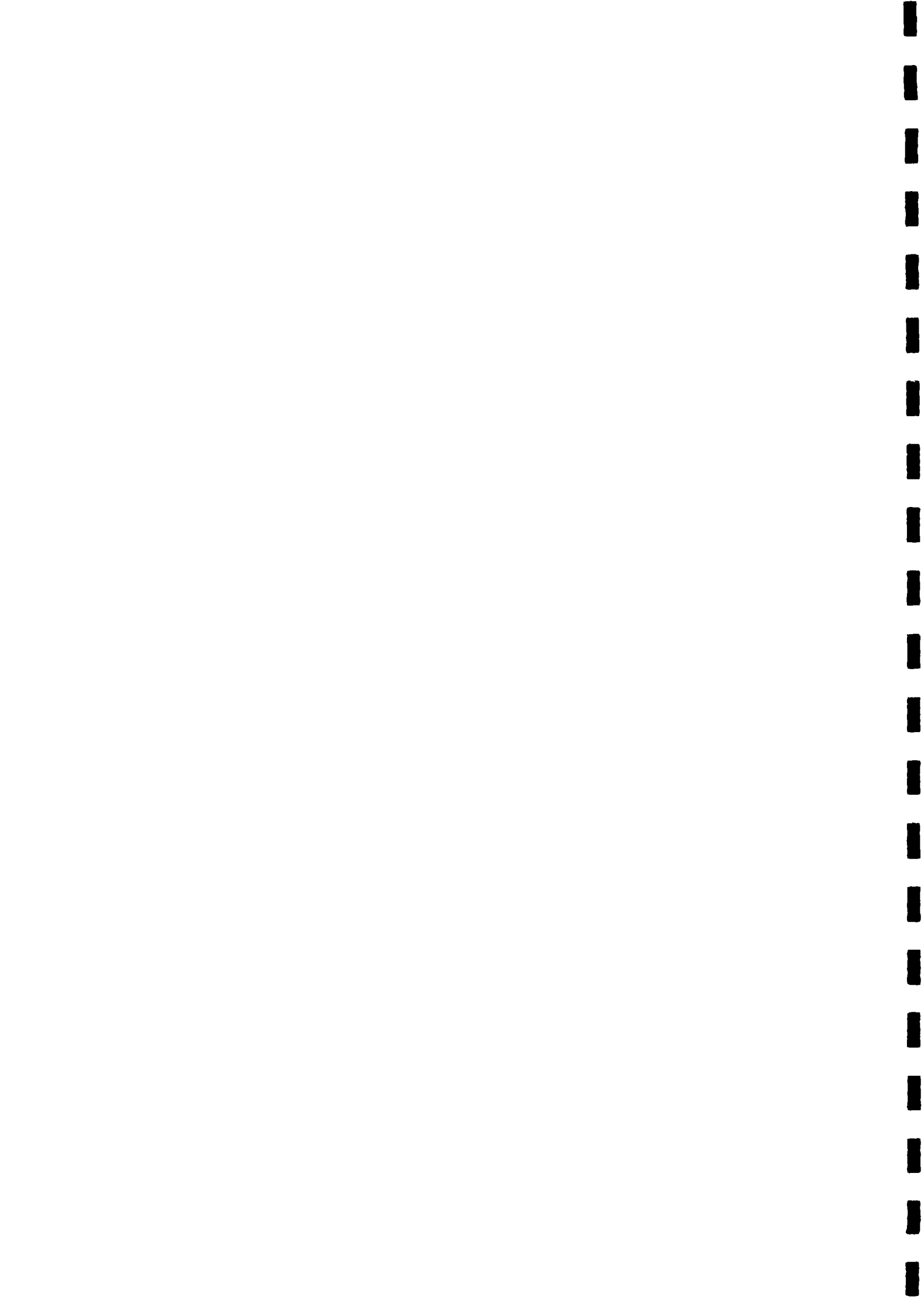

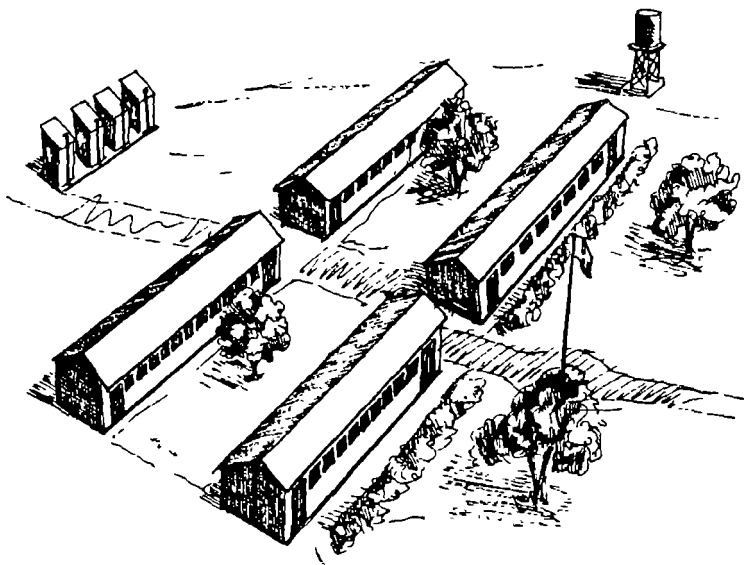
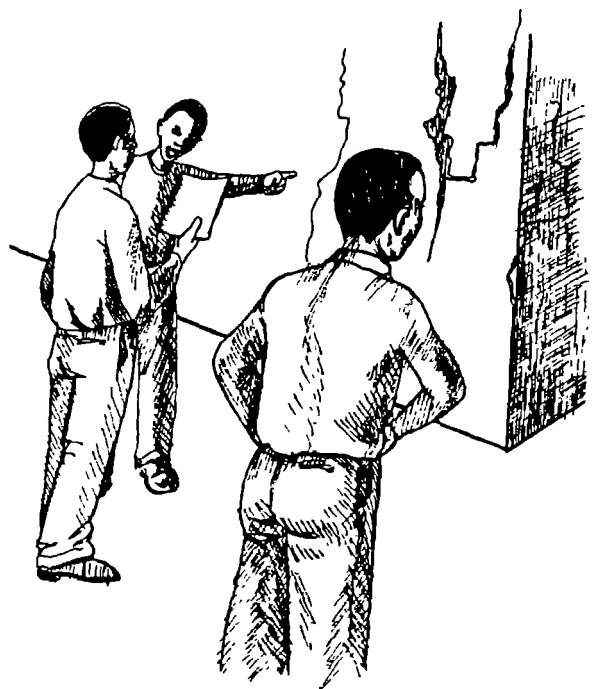
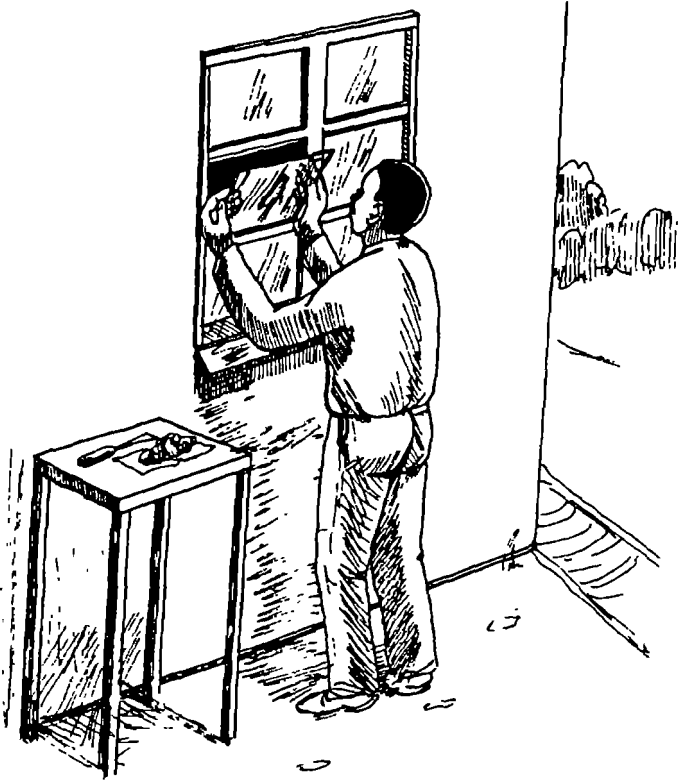

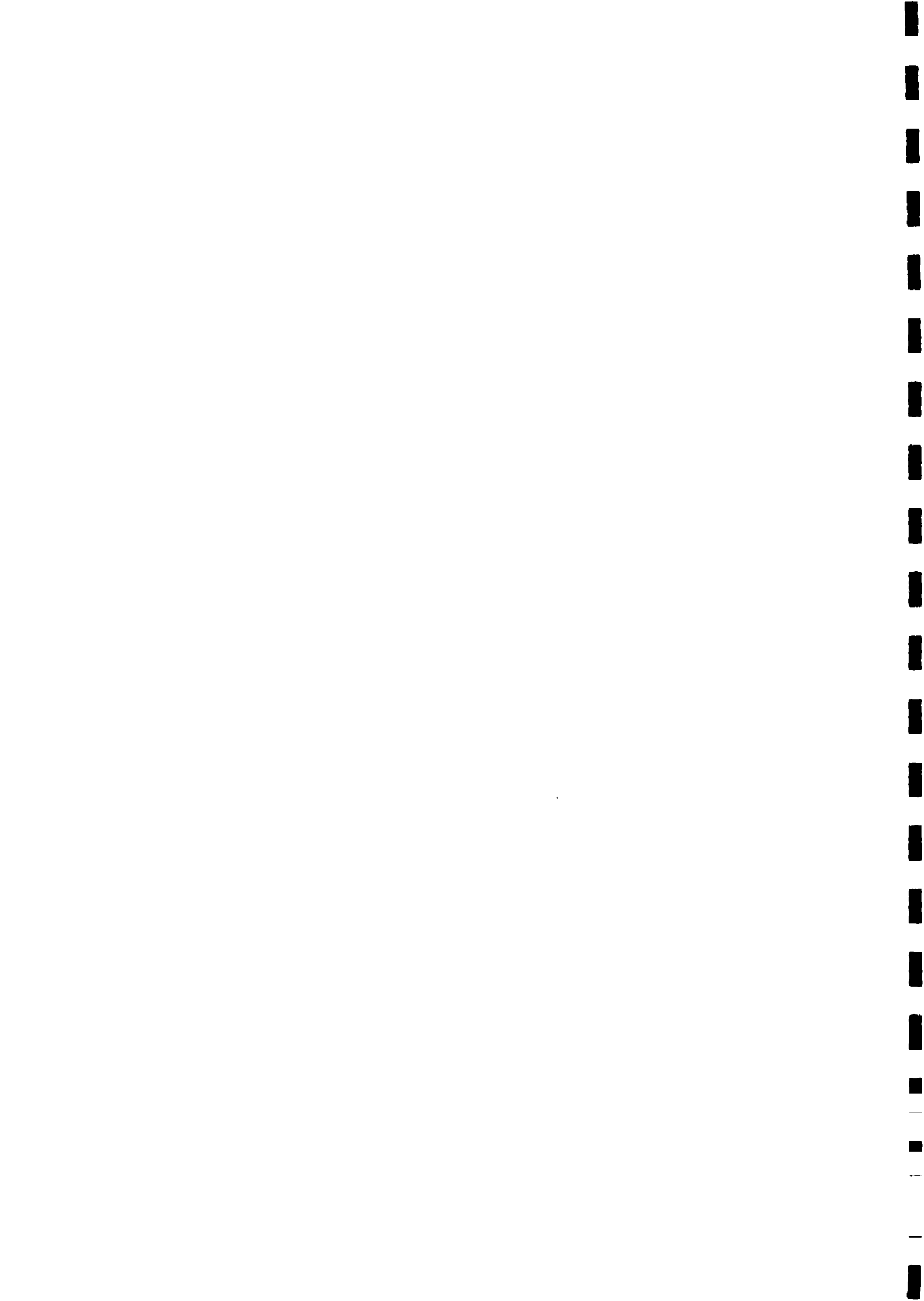

THIS MANUAL WAS PREPARED FOR THE SOCIAL RECOVERY PROJECT OF THE MICROPROJECTS UNIT, NATIONAL COMMISSION FOR DEVELOPMENT PLANNING BY.

Text:

Ms Barbara Collinson (MASDAR ZAMBIA Ltd)
Mr Boyd Sythes (TDAU, UNZA)

Illustrations:

Volume I Mr B H D Ford

Volume II Mr P Machere

Layout and Design:

Volume I Pilcher Graphics

Volume II Ms P McLellan (UNICEF)

Editing Ms B Collinson, Mr B Sythes

ZAMBIA 1994

The Microprojects Unit wishes to encourage the widest possible use of the material contained in this manual. However, full acknowledgement must be made to MPU, NCDP, Lusaka in any reference to or reproduction from the manual.

No reproduction in any form of any part of this manual may be made for any form of remuneration, including third parties, without the prior consent of MPU, NCDP.

Statements made in this manual should not be attributed to the Microprojects Unit and/or NCDP.

The contents of this manual do not refer to any person or group of persons living or having lived in Zambia.

The Microprojects Unit disclaims responsibility for any incident arising in any way from the use or interpretation of any content of this manual.

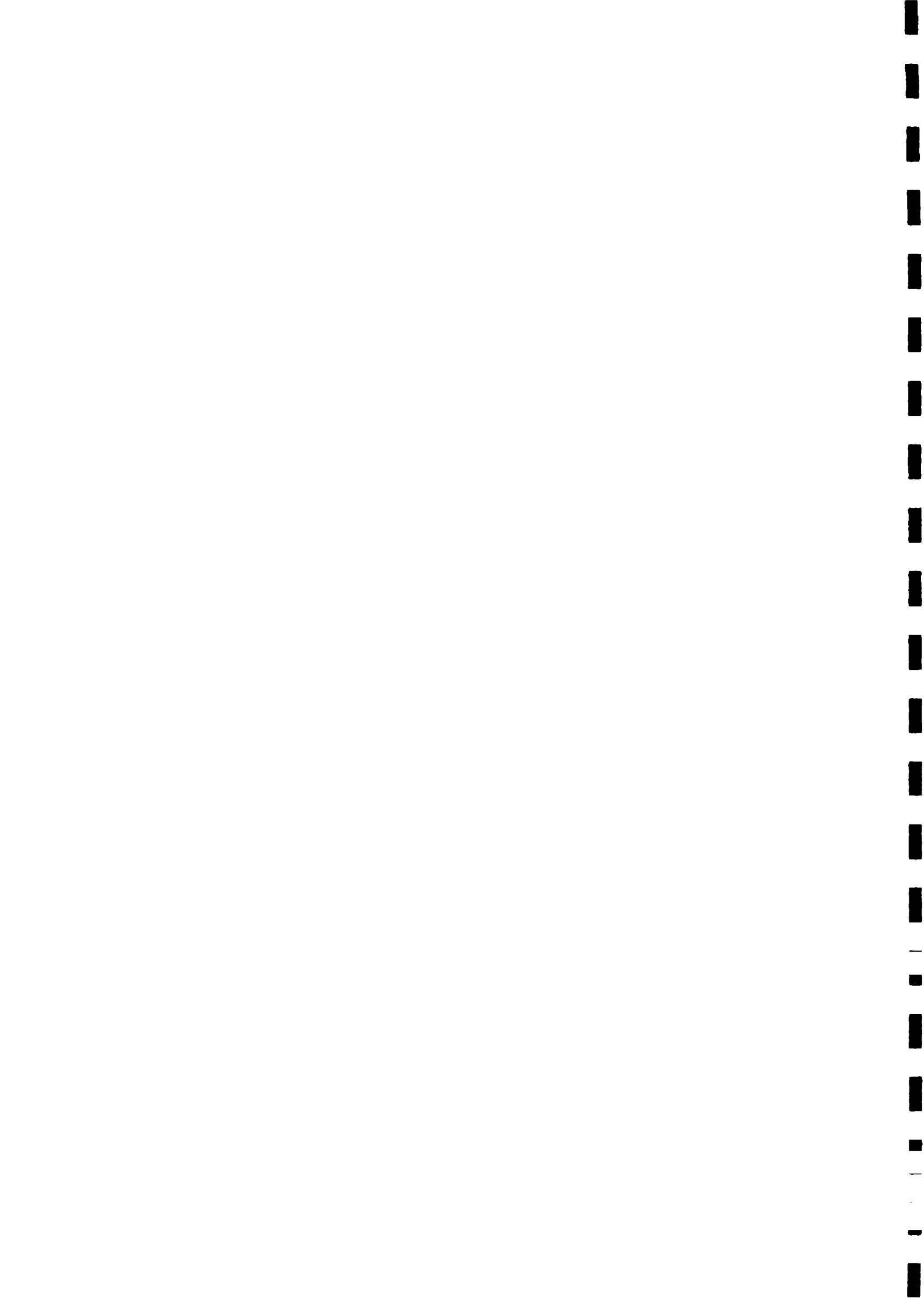

TABLE OF CONTENTS

CHAPTER 1	INTRODUCTION	1
	HOW TO USE PART 2	2
	ESSENTIALS FOR GOOD BUILDING	3
CHAPTER 2	EXERCISE	5
	THE PURPOSE OF THIS EXERCISE	6
	THE TROUBLE SHOOTERS CHECKLIST	6
CHAPTER 3	PLANS	9
	HOW THE BUILDING IS DRAWN	10
	EXAMPLE	11
	SECTIONS	12
	HOW TO USE THE PLANS	13
	TECHNICAL TERMS	13
CHAPTER 4	TOOLS	15
	THE IMPORTANCE OF TOOLS	16
	TOOLS YOU WILL NEED	16
	CARE OF TOOLS	17
CHAPTER 5	BRICKS	19
	CHOOSING THE RIGHT SOIL FOR YOUR BRICKS	20
	CHOOSING THE RIGHT SITE FOR YOUR KILN	21
	PREPARING THE SOIL	22

MOULDING THE BRICKS	23
DRYING THE BRICKS	26
PREPARING THE KILN	27
WOOD FOR THE KILN	27
FIRING THE BRICKS	29
Drying Out Excess Moisture	29
Making the Bricks Strong	30
Testing the Bricks	30
Cooling the Kiln	31
CHECKING THE RESULTS	31
CHAPTER 6	CEMENT, CONCRETE, MORTAR AND PLASTER
	33
INTRODUCTION	34
MIXES	34
Cement	35
Sand	35
Stones	37
GRADING	37
MIXING THE MATERIALS	38
Quantities	38
Mixing	39
CONCRETE	42
Pouring and Compacting	42
Curing Concrete	43
MORTAR AND PLASTER	44
REINFORCING MATERIAL	45
CHAPTER 7	VENTILATED IMPROVED PIT LATRINES (VIP's)
	49
THE LEARNING PROCESS	50
HOW A VIP WORKS	50

HOW TO BUILD A VIP LATRINE	52
Siting the VIP	53
Digging the Pit	53
The Foundation	53
The Slab	54
The Structure	56
The Vent Pipe	56
ALTERNATIVE DESIGNS	58
Urban Areas	58
Extra Light	58
Other Changes	58

CHAPTER 8 SITING 61

DECIDING WHERE TO PUT BUILDINGS 62

SELECTING A SITE	62
Soil	62
Level	62
Trees	62
Other Buildings	63

DIRECTION	63
Wind	63
Sun	63
Other Buildings	64

CLEARING THE SITE	64
Water	65
Mixing Slab	65
Paths	66

CHAPTER 9 SETTING OUT 67

SETTING OUT	68
Preparation	68
Accuracy	69

THE OUTSIDE WALLS	69
The 3-4-5 Method	70

PROFILE BOARDS	71
----------------	----

INSIDE WALLS	73
--------------	----

BUILDING ON A SLOPE	74
CHAPTER 10	THE FOUNDATION
WHAT IS THE FOUNDATION	75
DIGGING THE FOUNDATIONS	76
Digging the Foundation Trenches	78
Modifications for Weak Soil	79
Marking the Depth of Footing Concrete and Levelling	79
The Footings	80
The Foundation Wall	81
Plastering and Backfilling	82
Ant Treatment	83
Veranda Poles and Piers	83
CHAPTER 11	THE FLOOR
INTRODUCTION	85
THE FILL	86
ANT POISON	87
DAMP PROOF MEMBRANE (DPM)	87
THE SLAB	88
LAYING THE SLAB	90
Preparation	90
Dividing Up the Area to be Laid	91
Conforce	92
Pouring the Slab	93
Curing	93
SHRINKAGE AND EXPANSION GAPS	93
Inside Floors	93
Outside Floors	94
BRICK OR BLOCK SLABS	94
THE FLOOR SCREED	95

CHAPTER 12	WALLS	97
MORTAR		98
BONDING		99
LOAD BEARING AND NON-LOAD BEARING WALLS		100
LAYING THE BRICKS		100
TERMITE GUARDS		101
DAMP PROOF COURSE		102
THE FIRST COURSES		103
CORNERS		103
MAIN WALLS		104
BRICKFORCE		104
AIR BRICKS		105
ROOF TIES		105
GABLES		105
POINTING AND RAKING OUT		106
CHAPTER 13	DOORS, WINDOWS AND LINTOLS	107
METAL FRAMES OR WOODEN FRAMES		108
WHEN TO FIT DOOR AND WINDOW FRAMES		108
FIXING DOOR AND WINDOW FRAMES IN PLACE		109
GLASS OR FANCY BLOCKS		109
Glass		109
Fancy Blocks		110
FANCY BLOCKS		110

WINDOW CILLS	111
LINTOLS	111
Cast In-situ Lintols	112
Pre-cast Lintols	112
MAKING A LINTOL	112
BURGLAR BARS	114
CHAPTER 14	THE ROOF
	117
PARTS OF A ROOF	118
TIMBER	119
Seasoning	119
Choosing your Timber	119
Storing Timber	120
Ant Treatment	120
TYPES OF ROOF COVERING	121
Asbestos Cement Sheets	121
Galvanised Iron Sheets	121
Tiles	121
PLANNING THE ROOF	122
Length of Sheets	122
Number of Each Sheet	122
Number and Spacing of Purlins	123
CONSTRUCTING THE ROOF	123
The Wall Plate	123
Trusses	124
Purlins	126
Buildings Without Trusses	126
Roof Connections	127
Mitring	128
Fixing Roof Sheets	128
The Ridge	129
CHAPTER 15	FINISHING
	131
PLASTERING	131
WHEN TO PLASTER	132
APPLICATION OF PLASTER	132

JOINTS	133
CURING	136
PAINTING	136
TYPES OF PAINT	136
HOW MUCH PAINT	137
THINNERS	137
WHICH PAINT TO USE	138
GLASS	139
THICKNESS OF GLASS	139
PUTTY	140
DOORS	140
CHAPTER 16	ELECTRICAL AND PLUMBING
	143
SECURITY	144
MAINS ELECTRICITY	144
SOLAR POWER	145
MAINTENANCE OF SOLAR SYSTEMS	146
PLUMBING	147
CHAPTER 17	DRAINS
	149
THE IMPORTANCE OF PROPER DRAINAGE	150
3 BRICK DISH DRAIN	150
CONCRETE DRAIN	151

CHAPTER 18	REHABILITATION	153
REASONS FOR REHABILITATION		154
HOW TO CARRY OUT REHABILITATION		154
STRUCTURAL REHABILITATION		155
Foundations		155
Floor Slab		155
Floor Screed		155
Walls		155
Doors and Windows		156
Ceilings		157
Roof		157
REHABILITATION OF SERVICES		158
Water		158
Electricity		158
Sewerage		158
Drainage		159
Access		159
Environment		159
USEFUL TIPS		159
CHAPTER 19	WELLS	161
TYPES OF WELL		162
SITING		162
DIGGING THE WELL		163
RING MOULDS		164
TRANSPORTING RINGS		166
INSTALLING RINGS		166
DRAINAGE		168
CLEANING THE WELL		169
EDUCATION		170

CHAPTER 20	ROADS	171
	ROADS	172
	MITRE DRAINS	173
	CULVERTS	173
CHAPTER 21	A-Z OF TIPS	175
CHAPTER 22	GLOSSARY OF TECHNICAL TERMS	181
CHAPTER 23	INDEX	187

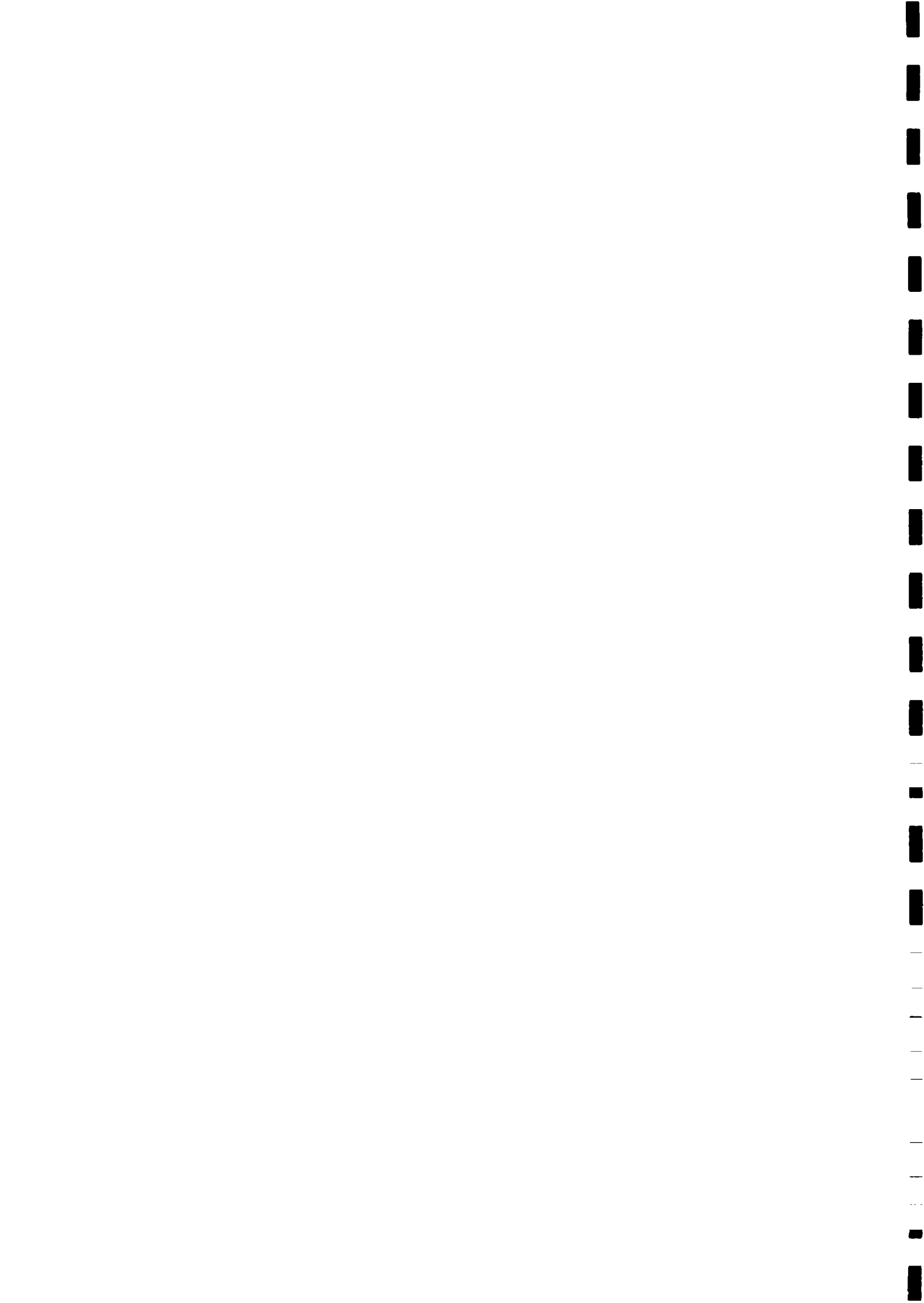



Introduction

What this book is for

How to use it

Essentials for good building

WHAT THIS BOOK IS FOR

The Project Implementation Manual is in 2 volumes. This is Volume 2. It should help you understand and answer many of the technical questions you may have during your project

Building does not have to be a mystery. It is not difficult to understand the theory of building - to know what is important and why.

However, the information in Volume 2 is ONLY A GUIDE.

It will not make you building experts. Building is a highly skilled job which takes years of practice to get right.

You have a qualified Supervisor, and experienced Foreman and skilled labourers working on your project. They are your experts.

HOW TO USE VOLUME 2

Each chapter deals with one stage of construction, from clearing the site, to painting the finished building. It also includes chapters on rehabilitation, roads, wells and VIP's.

Use this book to:

- help you understand what the builders are doing and why.
- check for yourselves that the builders are doing things right.
- ask the builders and Supervisor questions about what they are doing, so that they know you are going to make sure things are done right.

Some skilled labourers may be building in a certain way simply because they have not been told there are better ways. Watch what they are doing. Compare it to what is in this book. Discuss the different methods with your Supervisor, Foreman, Regional Officer, Buildings Officer and skilled labour.

Work together to make the best buildings possible.

ESSENTIALS FOR GOOD BUILDING

There are 7 things that you definitely need if your construction is going to be successful.

- 1. Supervisor:** you must have one He must be qualified and experienced and he must visit your site regularly, if he is not resident
- 2. Materials:** your materials must be good quality and be at the site when they are needed. They must be stored properly and securely
- 3. Plans:** you must have a full set of plans for all your buildings and make sure they are followed closely
- 4. Money:** you must manage your finances so that you always have money available to buy materials and pay your labour, or else building will be delayed
- 5. Time:** you must meet the time schedules specified by MPU
- 6. Labour:** the labour you employ must be highly skilled and enthusiastic
- 7. Committee:** the Committee is there to manage the project You should have at least one person with technical knowledge who can judge how well things are going. If you use this book properly, most of the committee should be able to understand what is going on

Above all else, **PAY ATTENTION TO DETAILS** and your building will last a long time.

There are often alternative ways of doing things If you read this book carefully you will be able to discuss these alternatives with your Supervisor and choose the methods most appropriate for your project

Exercise

To assess existing buildings in your area

To become familiar with common problems in building

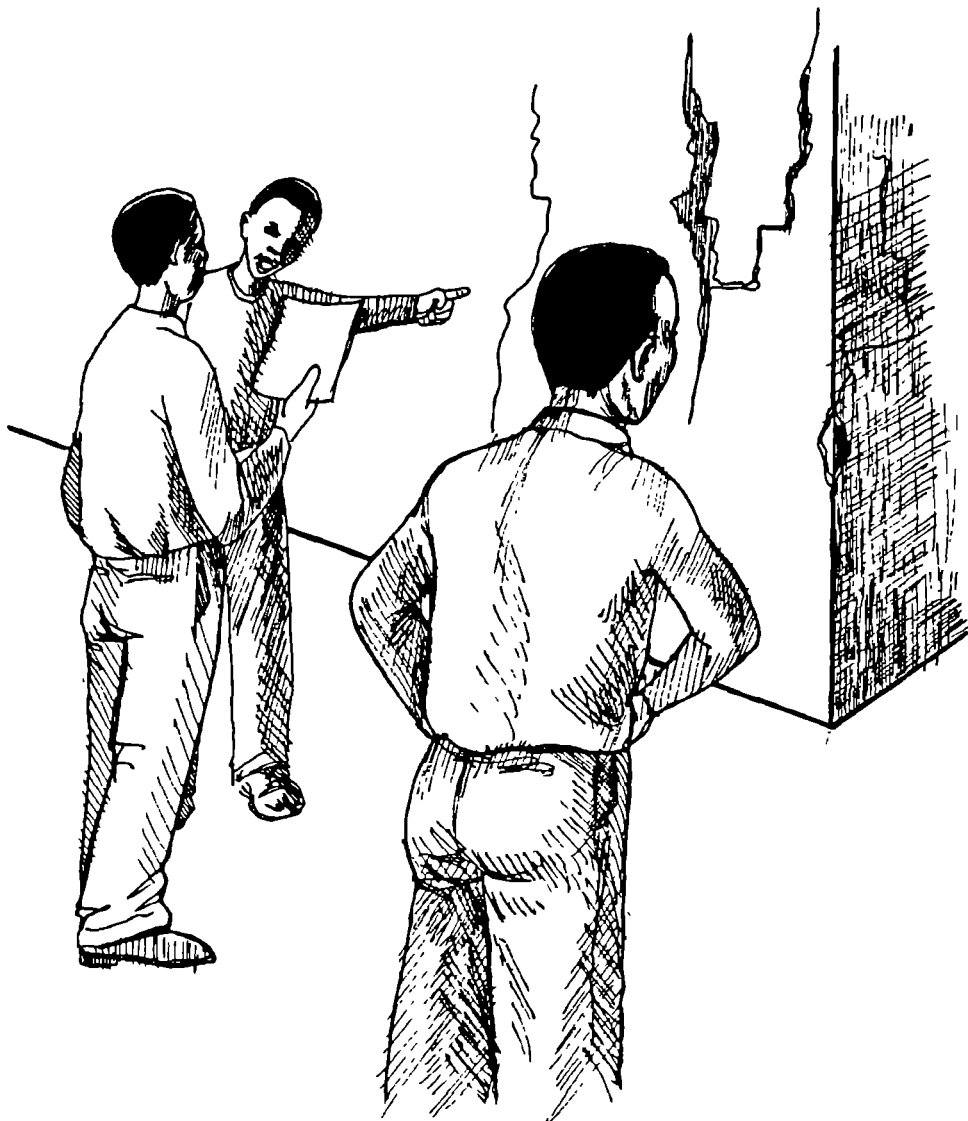

THE PURPOSE OF THE EXERCISE

This exercise is intended to give you some idea of the importance of the topics that we will discuss in this book.

-Take this Trouble-Shooters Checklist and go around buildings in your project area.

-Look at each of the main areas and see if you can spot any of the problems mentioned.

-If you do find some of these problems, the checklist tells you what might have caused them and what should have been done to prevent them.

As you read the rest of this book, remember what you have seen in your existing buildings

Take care not to let the same problems occur in your new buildings.

THE TROUBLE-SHOOTERS CHECKLIST

AREA	PROBLEMS	CAUSES	SOLUTIONS
SLAB	small cracks	concrete shrinking as it cures	keep concrete damp as it cures
		stress	more care with compacting the hardcore base
	large cracks	no reinforcement in the slab	use reinforcement
		poor concrete mix	take care with quantities and mixing, slab should be 1:2:4

AREA	PROBLEMS	CAUSES	SOLUTIONS
LINTOLS	does it sag or have cracks in it, or are there diagonal cracks from the corners of doors and windows	no reinforcement	use rebar in lintels
		poor mix	take care with quantities and mixing, lintels should be 1:2:4
		large stones in mix	largest stones should be 25mm across
WALLS	are there large cracks in the wall	possible subsidence due to weak foundations	foundations needed to be deeper or strengthened
	is the mortar thickness very uneven	careless brick-laying	more care needed
		bricks are different sizes	all bricks must be the same size
are there cracks in the bricks or blocks	poor quality bricks or blocks	more care needed to make good bricks or blocks	
ROOF	have termites attacked the timber	untreated timber	all timber must be treated
	has the timber twisted	they used wet timber, which twists as it dries	ensure your timber is completely dried
	are the trusses bent and sagging	poor carpentry	ensure you use skilled carpenters
TERMITES	are there lots of termite trails on the building	no termite poison	put poison in slab and foundation
		no termite guards	build termite guards into your building
PLASTER	are there small cracks in the plaster	plaster shrinks as it cures	allow plaster to dry properly
	are there large holes or cracks in the plaster or is it loose	poor mix	take care with quantities, materials and mix

KEY POINTS

- remember the *problems you have seen*
- *do not let the same problems occur in your new buildings*

Plans

The purpose of plans

How plans are drawn

Using plans

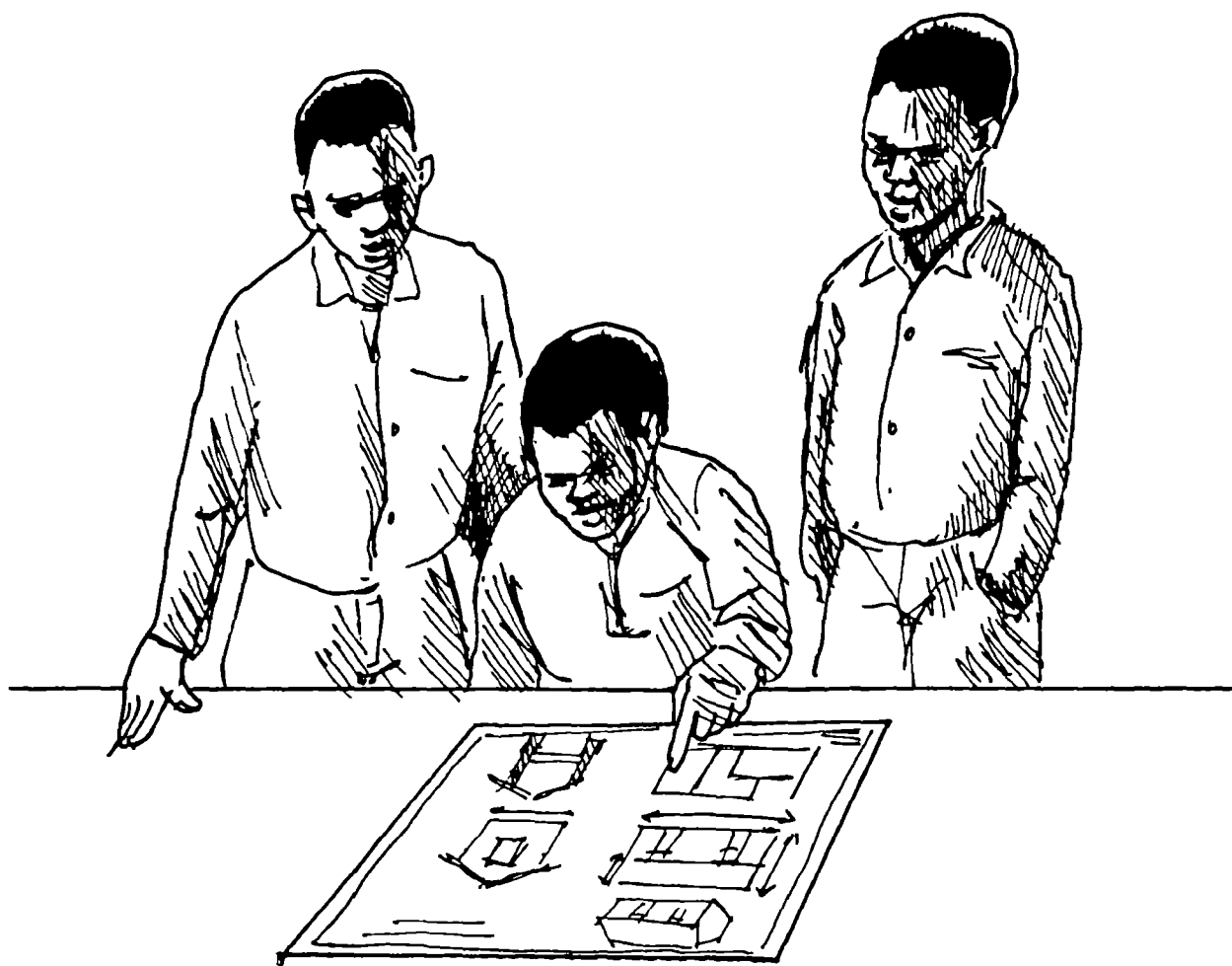

INTRODUCTION

The building plans should contain all the information you need to construct each building - measurements, construction notes and special materials.

Take time to understand these plans. Ask your Supervisor to help you. It is the only way to check what the builders are doing.

HOW THE BUILDING IS DRAWN

Building plans are drawn in a special way, giving as much information as possible in a limited space.

Each drawing on a plan has a different name. The main ones are.

1) The FRONT ELEVATION

What you would see if you looked straight at the front of the building. There might also be a BACK (or REAR) ELEVATION.

2) The SIDE ELEVATION

What you would see if you looked straight at the side of the building. There might be a LEFT SIDE ELEVATION and a RIGHT SIDE ELEVATION.

3) The ROOF PLAN

What you would see if you looked down from the sky, directly on top of the building. It is often drawn without the roof sheets shown.

4) The FLOOR PLAN

Looking down from the sky on top of the building BEFORE the roof is fitted.

5) The FOUNDATION PLAN

Looking down from the sky on top of the building BEFORE the slab is laid.

6) SECTIONS

Imagine that you have cut the building in two. The section is what you would see if you looked straight at one cut piece. There may be several sections.

7) DETAILS

These are small areas of the building and are drawn larger to give more information about how they are constructed.

EXAMPLE

Look at this building.

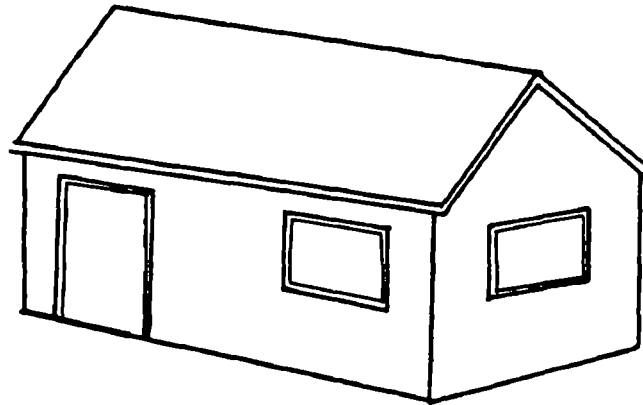

A simplified plan for this building is shown below. A proper plan would include much more information, but try to understand this one first. Then compare it to the plans MPU sent you for your buildings.

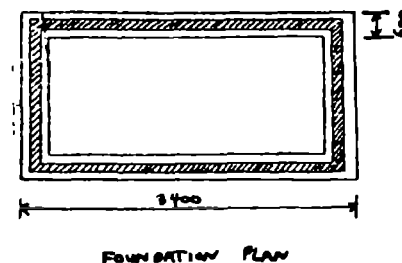
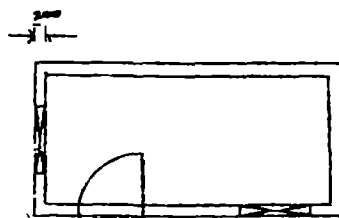
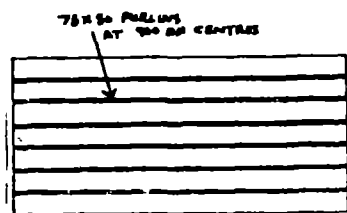
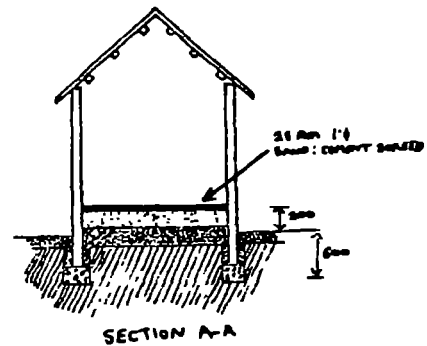
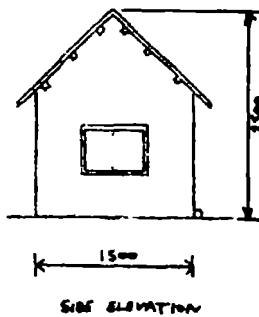
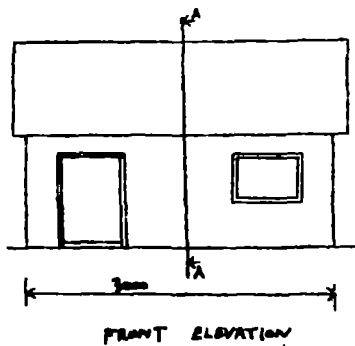

Can you see that the measurements are given on different elevations. It will be the same with your building plans. If you cannot find a measurement on one elevation, look for it on other elevations. Everything should have a measurement somewhere on the plan.

SECTIONS

Sections are necessary to be able to see details of things that would be hidden in the other views.

There may be several sections on your plans. Each section will have its own name, such as Section AA, Section BB and so on. Look for a line in one of the elevations that has an "A" at each end. This is where Section AA came from

Look at the example again. Do you see how the section was drawn? Imagine the building being cut in two along the line with an "A" at each end

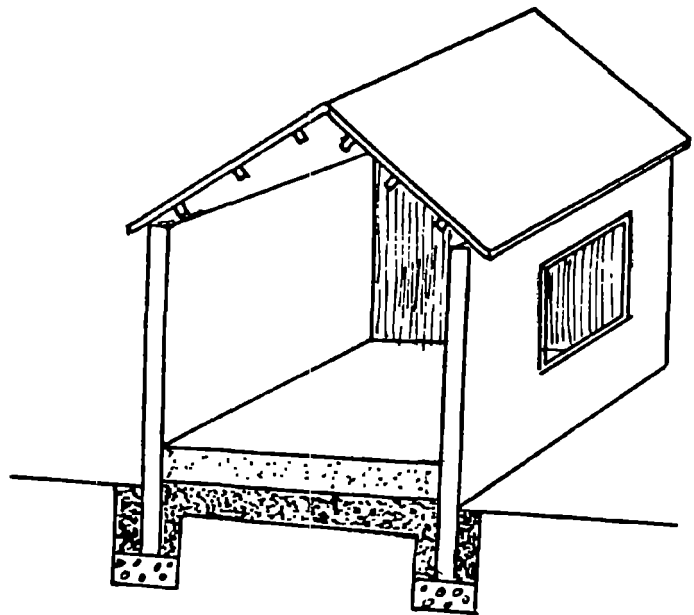

Do you see how this looks like the view called Section AA? If not, get the Supervisor to help you.

Do you see why the section is important? Without it you would not know how deep the foundations are, or be able to see details of the floor. The section gives us information that no other elevations can

Take time to understand about sections. There will be sections on all your plans and there are also some used in this book.

HOW YOU SHOULD USE PLANS

Your Supervisor and Foreman will be using the plans all the time to construct the building properly. You should use the plans to check:-

- (1) SHAPE:** is the building going to be the right shape?
- (2) SIZE:** all the dimensions are on the plans.
- (3) MATERIALS:** the plans will often say what type of materials should be used.
- (4) METHODS:** the plans also give written notes on construction of certain things.

TECHNICAL TERMS

The plans will include technical terms. Look up the Glossary to find out what these terms mean.



Tools

Importance of tools

Tools you will need

Care of tools

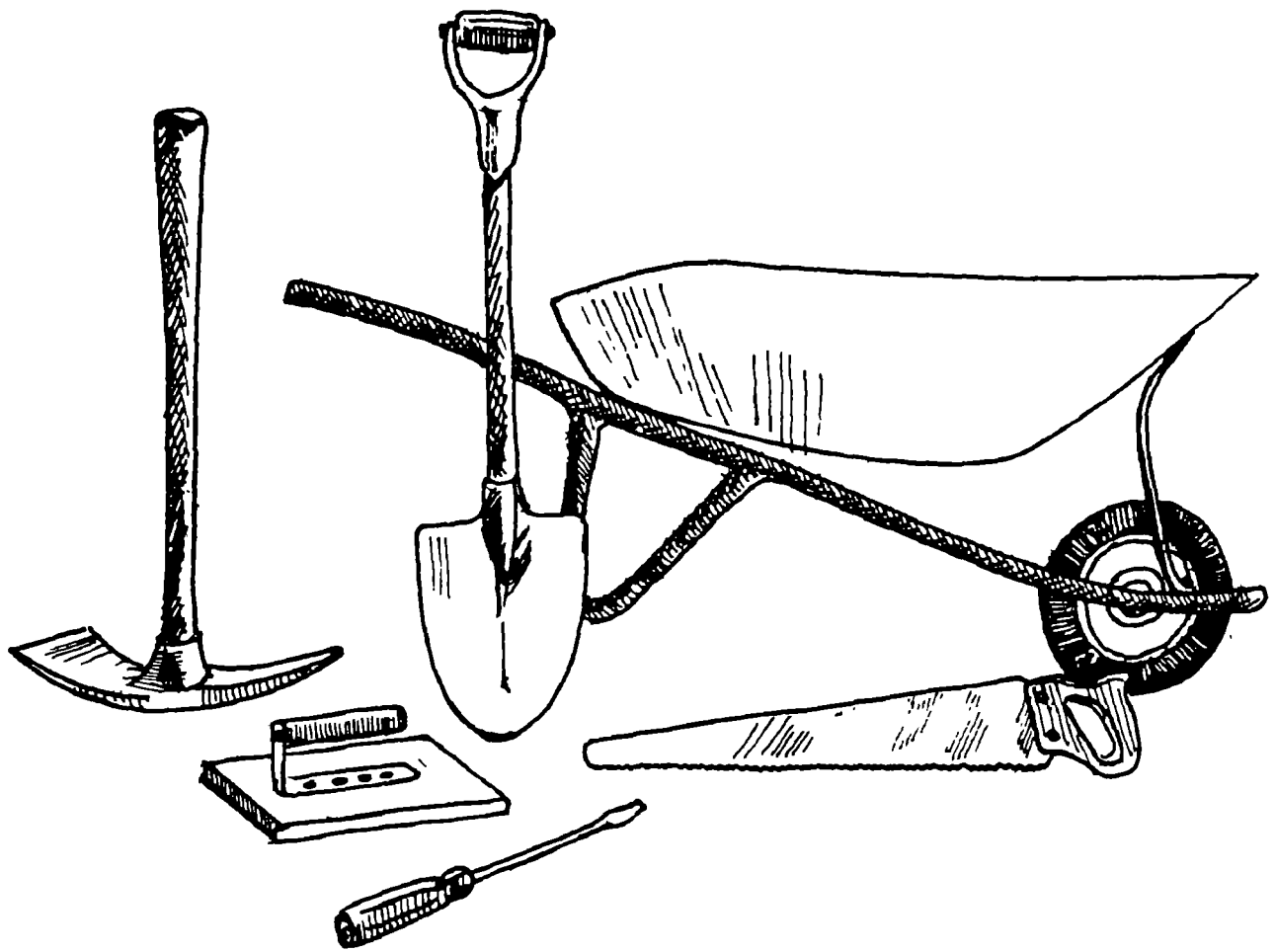

THE IMPORTANCE OF TOOLS

It is very difficult to produce good quality work using bad tools.

Many people judge a skilled worker by the tools he uses. A good craftsman will usually have his own tools, which he has kept in good condition over many years. He will only use a tool for the job it was intended to do.

If the craftsman has kept his tools carefully, there is a good chance he will also build carefully.

On the other hand if he has few tools and they are damaged or broken, he may well produce bad work.

TOOLS YOU WILL NEED

The main tools you will require for your project are listed below. If you have some of these, make sure they are in good condition.

MPU will usually include some of these in your project budget:

- iron buckets
- shovels with metal handles
- picks
- building trowels
- building lines
- large paint brushes
- small paint brushes
- claw hammers
- glass cutters
- pointing trowels
- metal float
- wooden floats
- spirit levels
- measuring tapes
- wheelbarrows
- building square
- outside corner
- inside corner
- large and small wood saws
- lump hammer
- hacksaw and blades
- pit saw (optional)

CARE OF TOOLS

- Store your tools carefully.
- Ensure they are cleaned at the end of each day by the people using them.
- Keep them sharp where necessary.

Your tools should last long after your project is completed and be available for maintenance in the future.

The Maintenance Committee should be made responsible for the proper care of all tools once the project is complete.

KEY POINTS

- keep tools sharp
- oil tools thoroughly before storing them
- you can judge a worker by his tools

Brick-Making

Choosing the right soil

Moulding the bricks

Firing the bricks

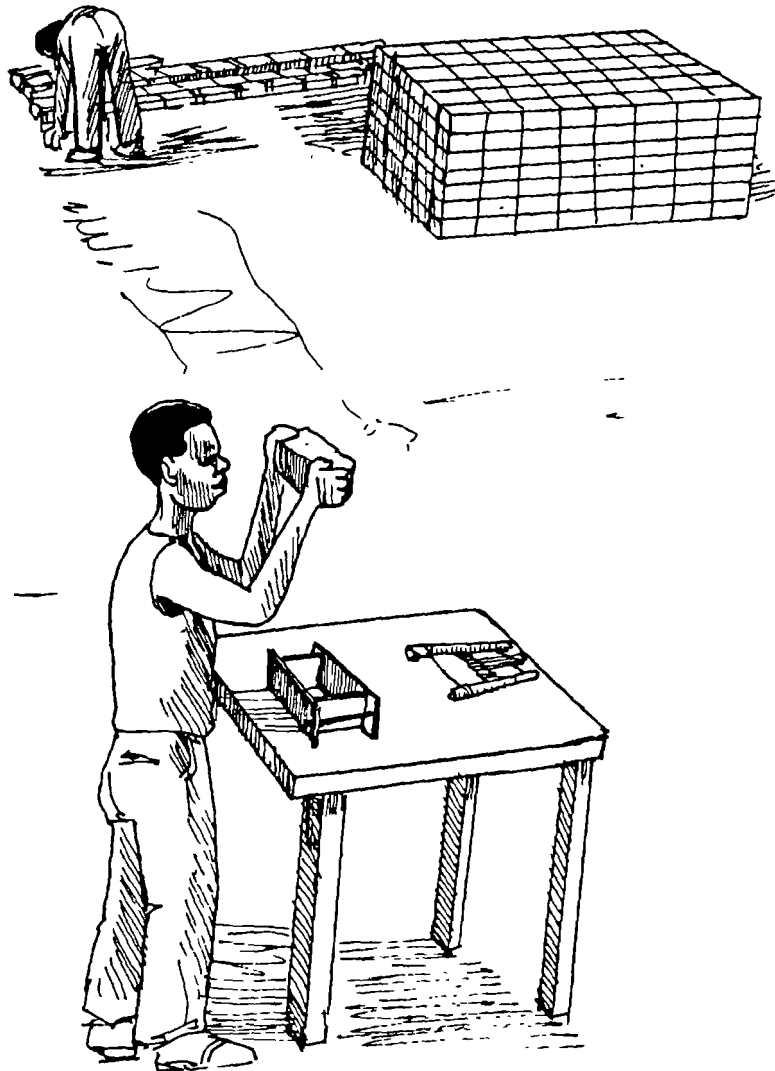

INTRODUCTION

Your building will only last if you use good materials. If you are building with burnt bricks, they must be very good quality.

You have probably made burnt bricks before. But there may be better ways of making them. People are always improving how things are done.

This chapter describes one method of making bricks, which is being used all over the world and will produce the best bricks.

CHOOSING THE RIGHT SOIL FOR YOUR BRICKS:

The best soil contains 2 parts clay and 1 part sand. Do not use soil containing large amounts of sand or silt.

Test the quality of the soil for brick-making in the following way:



1. collect a small amount of soil from the area where you are going to dig.
2. crush the soil and remove any stones,

3. add water slowly to the soil until it can be moulded into shapes in your hand.

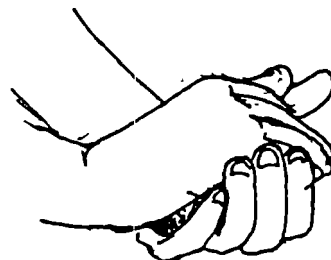

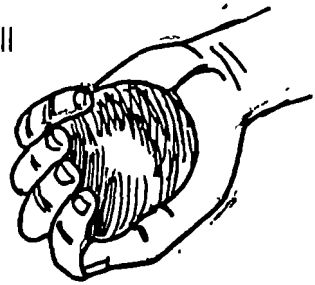
4. If it keeps falling apart, the soil contains too much sand or silt. Look for another site.
 5. If the soil can be moulded easily, make a ball the size of a guinea fowl egg. Leave it in the sun to dry.
- 
6. If the soil keeps its shape well and does not crack badly, then it will make good bricks.
 7. If the ball keeps its shape, but becomes very hard or has wide cracks, then it does not contain enough sand.
 8. Add sand to the soil and make more test balls until you have good, stable balls.
 9. If the ball goes out of shape or crumbles easily when dry, then it contains too much sand or silt and will not make good bricks. Look for another place to get your soil.
 10. Make and burn about 50 bricks before starting a large number. If these burn without twisting and cracking excessively then it is safe to continue. If not, look for other soil.

CHOOSING THE RIGHT SITE FOR YOUR KILN:

- Mould the bricks as close to the building site as possible.
- The site should be flat and cleared of plants, grass, leaves, etc.
- Build the kiln close to where the bricks are being moulded. This will reduce breakages of the dried bricks.
- The site for the kiln should be flat and level.

PREPARING THE SOIL:

-Cut and lift the soil in small quantities.

-Remove all stones, roots, leaves, etc.

-If you need to add sand to the soil, add it at this stage.



-Add water to the soil and tread the mixture with your feet to make mud. Treading will give a better mixture than using shovels, hoes, etc.

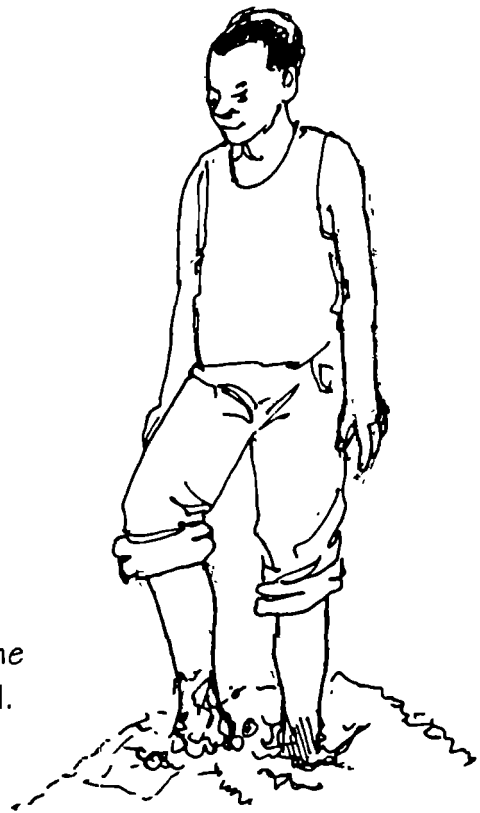

-Cover this mixture with grass, banana leaves, etc. and leave it for 3 - 5 days. The mud is ready for moulding when it has a heavy, sticky feel.

MOULDING THE BRICKS:

-It is much easier to make good quality small bricks than large bricks.

-You must use the same size of brick throughout the building.
MAKE SURE ALL THE MOULDS ARE THE SAME SIZE.

-Do not use twisted moulds.

-MPU base their quantities on a brick of 190mm long x 90mm wide x 90mm high.

-The mould for the bricks should be about 12mm larger all round than the final size required for the brick. This allows the mud to shrink as it dries.

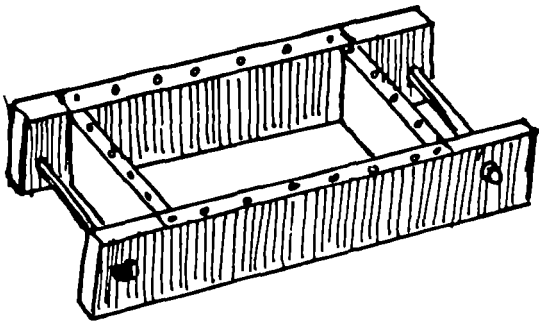

-If you nail a strip of metal around the edge of the mould it will be much stronger.

-Make the bottom of the mould from a piece of wood slightly smaller than the mould. This is used to push out the brick after moulding.

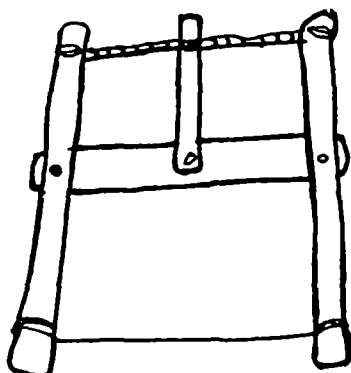
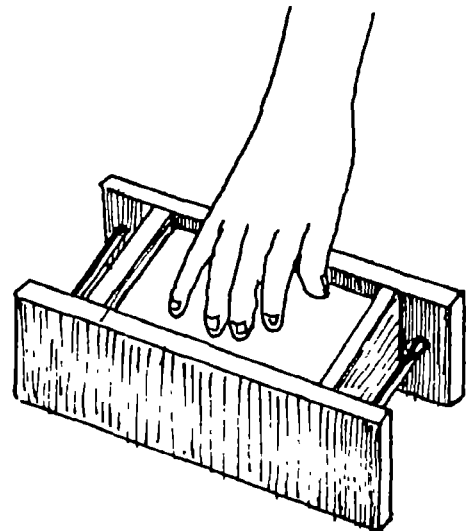

-Make a cutting tool by twisting a piece of thin wire between the prongs of a stick. The length of wire must be greater than the width of the mould.

-Leave the mould soaking in water for one or two days before using it to stop the mud sticking to the mould.

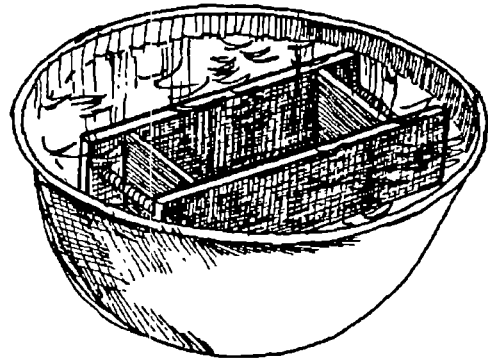

-Sprinkle the inside of the mould with fine sand. This will also reduce sticking. Sprinkle the mould with more sand every time the bricks become difficult to remove.

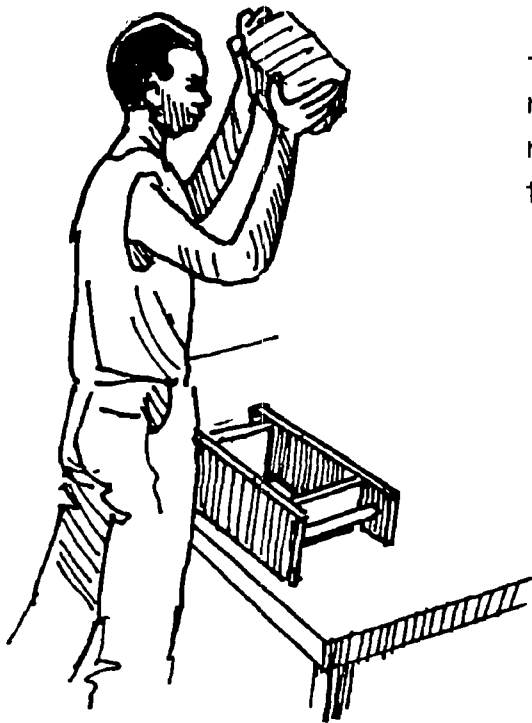

-Ensure the mud fills all the corners of the mould. This is best done by rolling a lump of mud slightly larger than the mould and throwing it into the mould with some force.

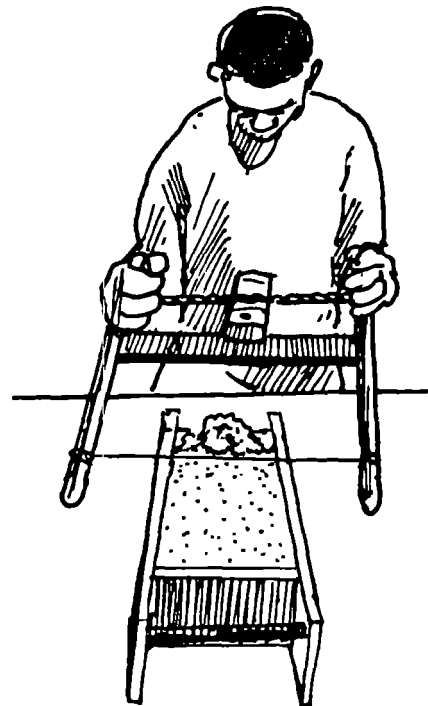

-Cut the excess mud away using the cutting tool.

-Carry the mould to the drying area and push the brick out using the smaller piece of wood. This will reduce twisting of the brick as it leaves the mould.

-If your moulds do not have this sliding bottom, try to knock the brick out in one go. DO NOT knock one end of the mould, then the other. This will twist the brick.

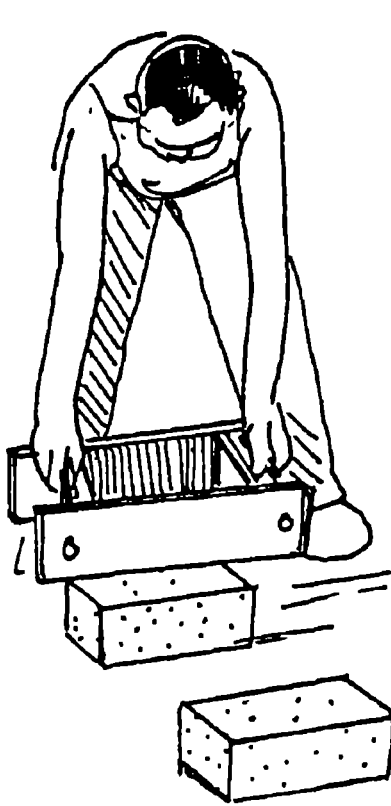

RIGHT

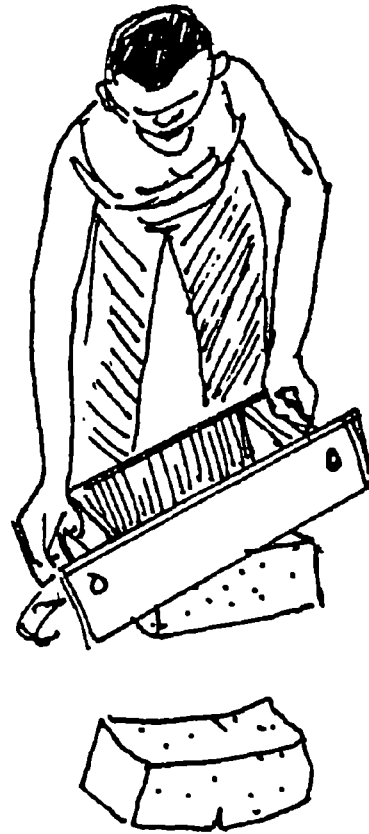

WRONG

-Make sure the people moulding the bricks have spare moulds to work with so they do not have to wait for the mould to be brought back.

DRYING THE BRICKS:

-Never just pile bricks in a heap.

-Lay the the bricks on the ground as shown in the illustration.

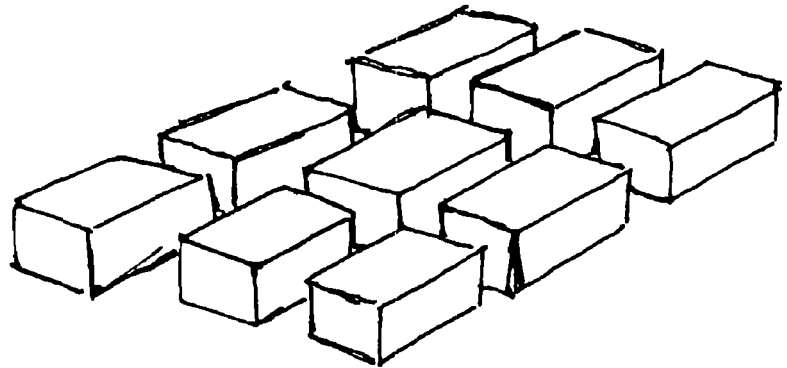
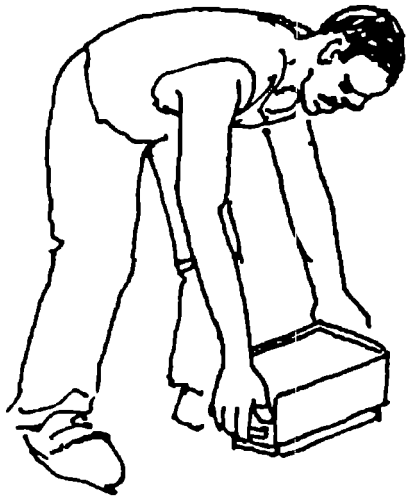

-Leave them in the sun for one day, or until they become hard.

-Turn the bricks on their edge and leave them for another 7-10 days.

-If you are running out of room, stack the bricks neatly as in the illustration after they have dried for a day or two.

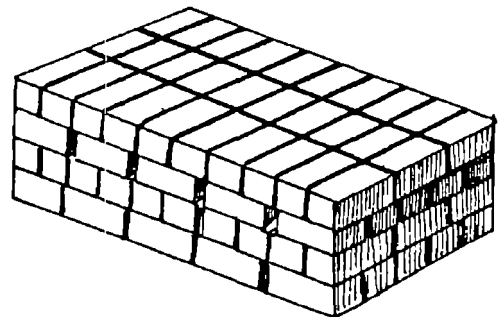

-Ensure the bricks are completely protected from rain when drying.

-Do not move the bricks until they are completely dry.

PREPARING THE KILN:

It is important to stack the bricks in the kiln correctly. The best method is shown in the illustration.

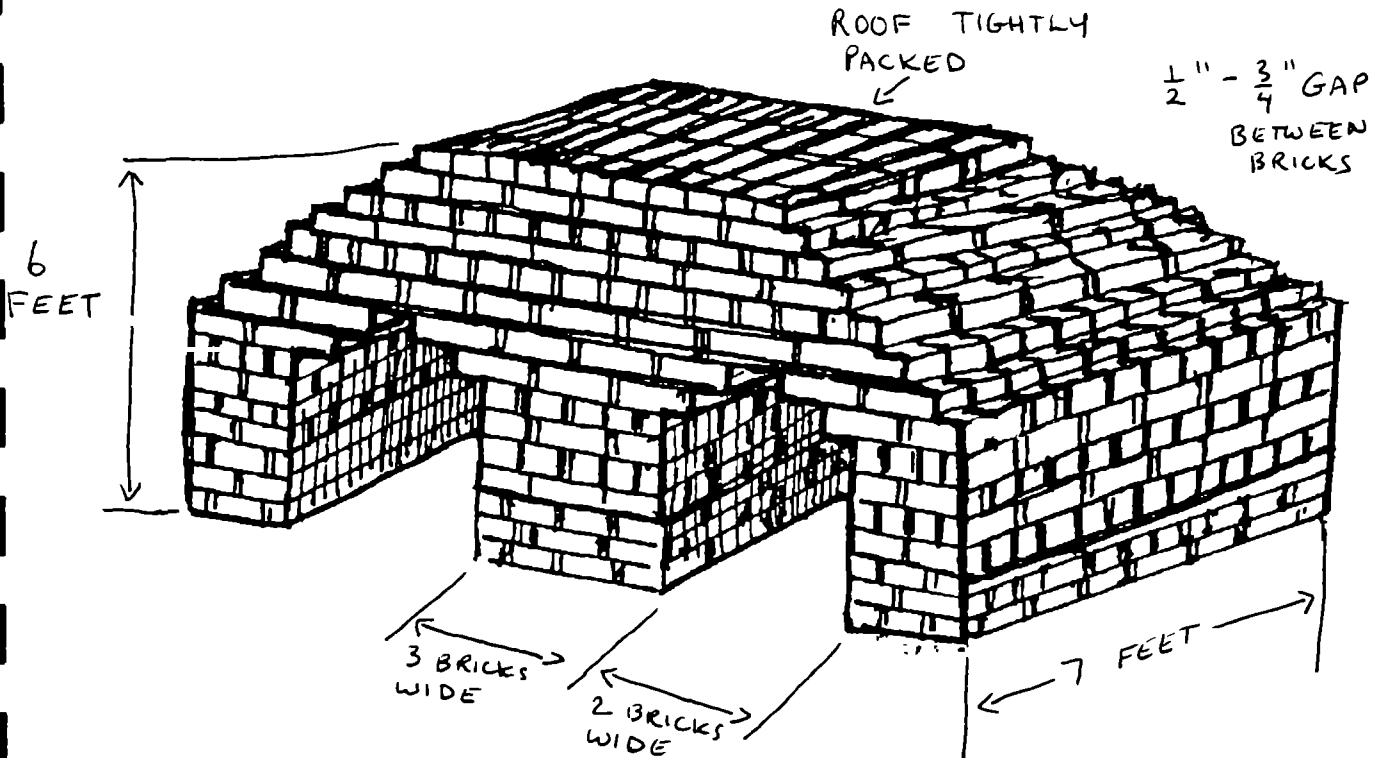

THE IMPORTANT MEASUREMENTS ARE THAT:

- there should be a gap of $\frac{1}{2}$ " to $\frac{3}{4}$ " between each of the bricks to allow the hot air to reach each brick,
- only the top layer of bricks should be tightly packed to form a roof,
- the stack of bricks should be 7 feet from front to back,
- the stack of bricks should be 6 feet tall,
- the width of the fire tunnels should equal the length of 2 bricks,
- the thickness of the wall between the 2 fire tunnels should equal the length of 3 bricks.

If the kiln is made larger than these measurements then the extra bricks will not get enough heat to burn properly

The walls of the kiln should be covered with a sealing layer at least 3-4" thick

DO NOT plaster the roof of the kiln at this stage

DOING IT THIS WAY ENSURES THAT:

- the stack of bricks will be strong and stable,
- the stack will not collapse as the firing takes place,
- less firewood will be needed,
- in the end, most of the bricks will be useable.

WOOD FOR THE KILN:

You will need about 1 ton or 3m³ of firewood for every 1000 bricks you are going to make.

Look at the illustration.

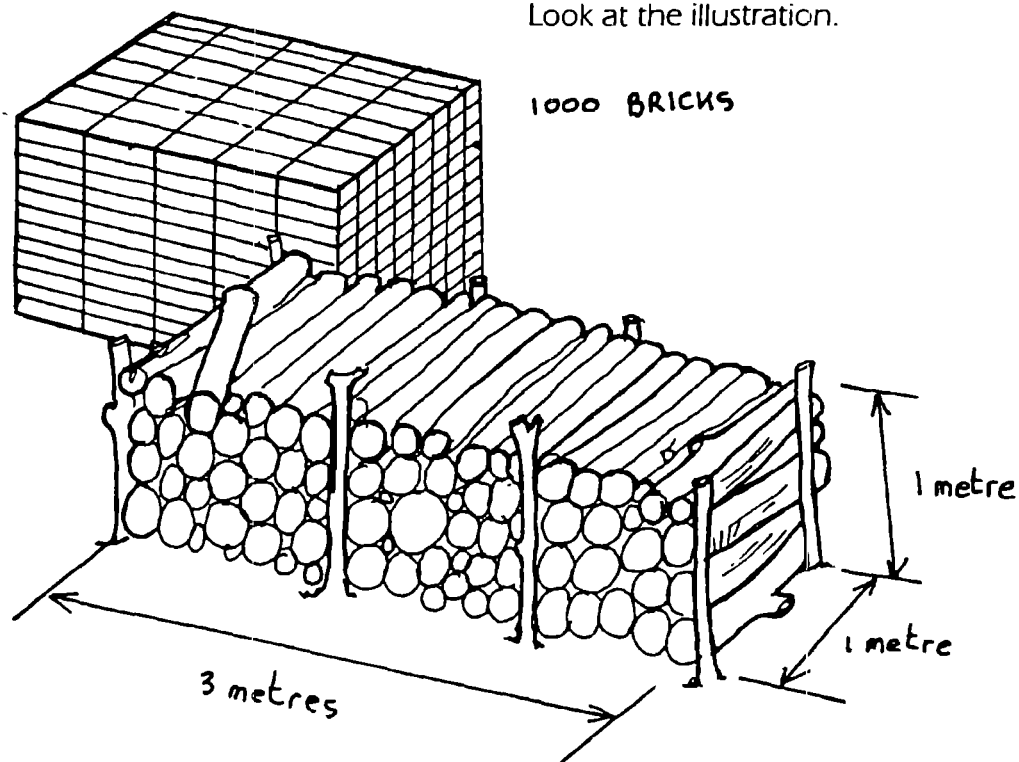

Stack the wood in this way
It is a good way of knowing how much wood you have collected

FIRING THE BRICKS:

There are 4 stages to making good bricks.

(1) DRYING OUT EXCESS MOISTURE

This is done before the roof of the kiln is plastered

-put logs of wood into the fire tunnels from both ends until the tunnels are half-full.

-decide which end of the tunnel is most sheltered from the wind and start the fire at that end. Do not let the fire burn too strongly at this stage. The object is only to dry out any moisture from the bricks.

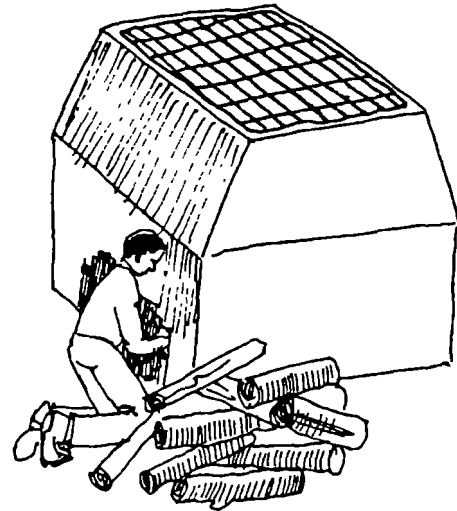

-there is no more moisture in the bricks when steam stops coming from the top of the kiln.

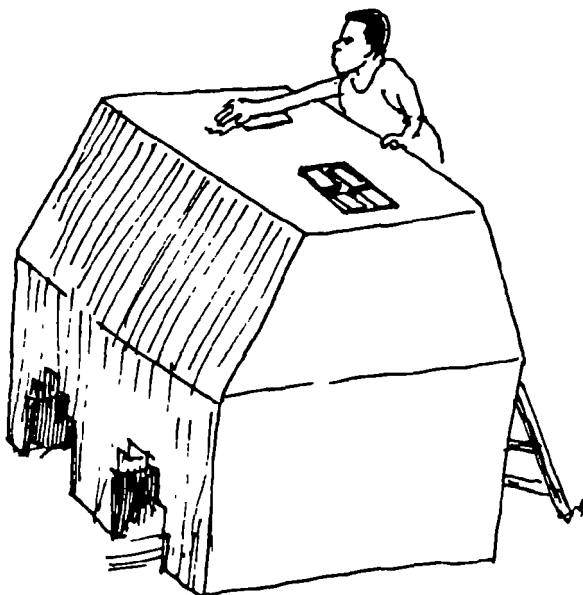

-now plaster the roof with mud. Leave one ventilation hole above each fire tunnel, to allow the air to circulate. The size of each hole should equal the size of 4 bricks, plus the 1/2" - 3/4" gap around them.

(2) MAKING THE BRICKS STRONG

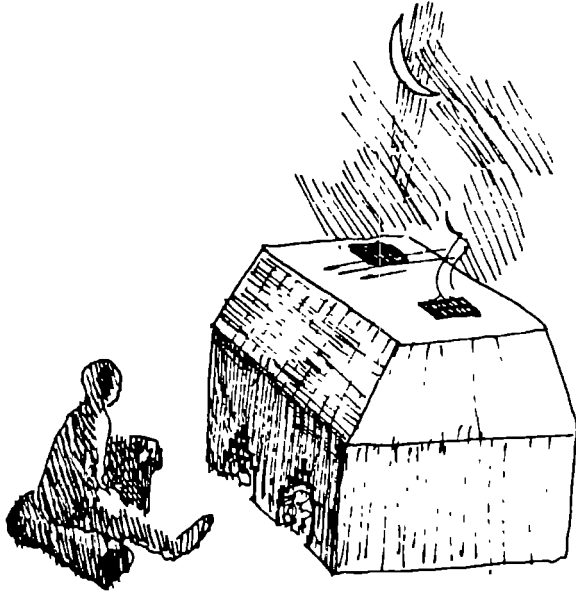

-add more wood to make the fire burn strongly.

-keep the fire burning strongly for 4-5 days.

-never let the fire die down, day or night.

If the wind does not change direction while you fire your bricks, you should burn only one end of the kiln at a time. Block the other end and let the fire burn for 2 days. Then block the end where you have the fire. Unblock the other end and light a fire there. Let it burn for another 2 days. Repeat this process as often as necessary until the firing is complete.

(3) TESTING THE BRICKS

Test the bricks before deciding that the firing is complete.

After the fire has burned for 4-5 days, scrape away some plaster from the middle of one side of the kiln. Take out 2 or 3 bricks and test them.

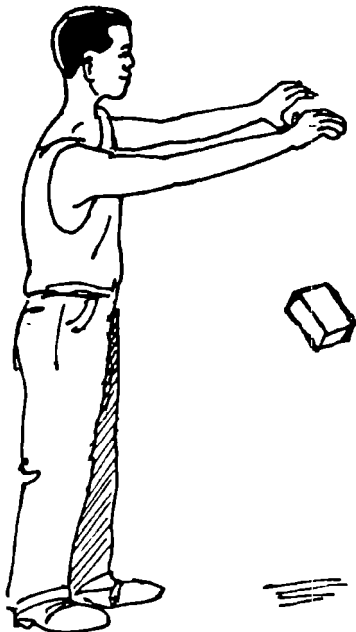

-If firing is complete the bricks will be difficult to break and should make a metallic sound when tapped together.



If the bricks break easily or make a dull sound when tapped together, replace the plaster and continue firing for another day or two. Repeat the test.

Do not overburn the bricks. Overburnt bricks are brittle and weak.

(4) COOLING THE KILN

When firing is complete, let the bricks cool slowly. Slower cooling makes stronger bricks.

-Seal the kiln. Close all openings, including the ventilation holes.

-leave the kiln to cool for 10-14 days.

CHECKING YOUR RESULTS:

Open the kiln and check the bricks.

-you should be able to use 85 or 90 out of every 100 bricks.

-if you cannot, try to improve with your next kiln.

Do not throw away bad bricks. Use them for:

- making the base of the next kiln,
- packing when making the floor of buildings or paths.

KEY POINTS

- *it is easier to make good quality small bricks than large bricks*
- *test the soil you intend to use*
- *ensure ALL your moulds are the same size and not twisted*
- *make sure the mud completely fills the mould*
- *NEVER pile burnt bricks in a heap*
- *ensure your kiln is stacked to produce the greatest number of well burnt bricks*
- *do not underestimate how much wood you need. Make sure it is ALL at the kiln before firing.*
- *test your bricks to make sure they are well burnt*

Concrete, Mortar and Plaster

Cement, sand and stones

Making the mix

Concrete

Mortar

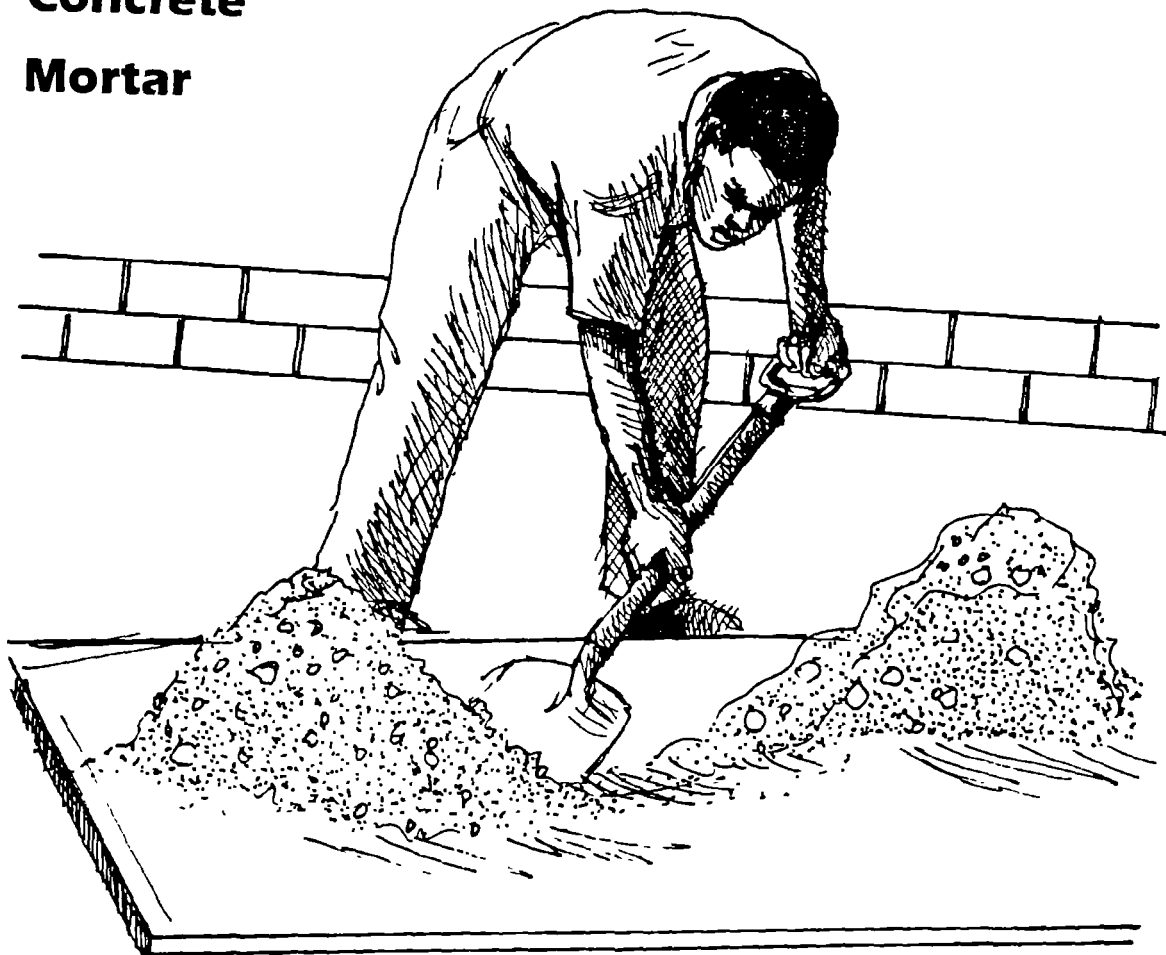

INTRODUCTION

Cement is mixed with sand, stones and water to make concrete

Cement is mixed with sand and water to make mortar and plaster

The strength of the concrete, mortar or plaster depends on

- the type of materials used in the mix,
- the quantities of each material in the mix,
- how well the materials are mixed.

This chapter will tell you how to choose the best materials and how to make the various mixes.

MIXES

Look at the table It tells you,

- the names of the different mixes you will be using,
- where each mix is used.
- a GUIDE to what ratios the materials should be mixed in, i.e. what volume of sand should be mixed with what volume of cement, etc.

GUIDE TO MIXES

Name of Mix	Where Used	Materials		
		Cement	Sand	Stones
Mass Concrete	Foundation	1 part	2 parts	4 parts smallest 0.5cm largest 6cm
Reinforced Concrete	Floor Slabs Lintels	1 part	2 parts	4 parts smallest 0.5cm largest 2.5cm
Screed	Floor	1 part	4 parts	none
Mortar	Bricks	1 part	4 parts	none
Plaster	Walls	1 part	4 parts	none

Each mix contains cement, sand and sometimes stones

(1) Cement

Only buy fresh cement. If it is lumpy, do not buy it or use it.

Cement is very easily spoiled, so it is very important to store it properly. Read volume 1, chapter 13 for details of storage.

The strength of any mix comes from a chemical reaction between the cement and the water. Sand and stones are added simply to increase the volume of the mix, but too much sand or too many stones will weaken the mix.

(2) Sand

Sand is used in all mixes. There are different types of sand

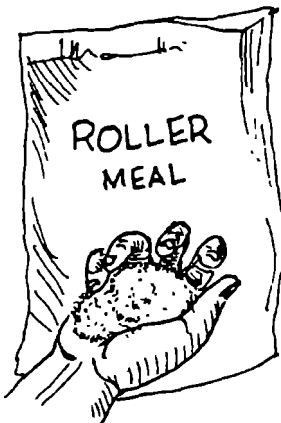
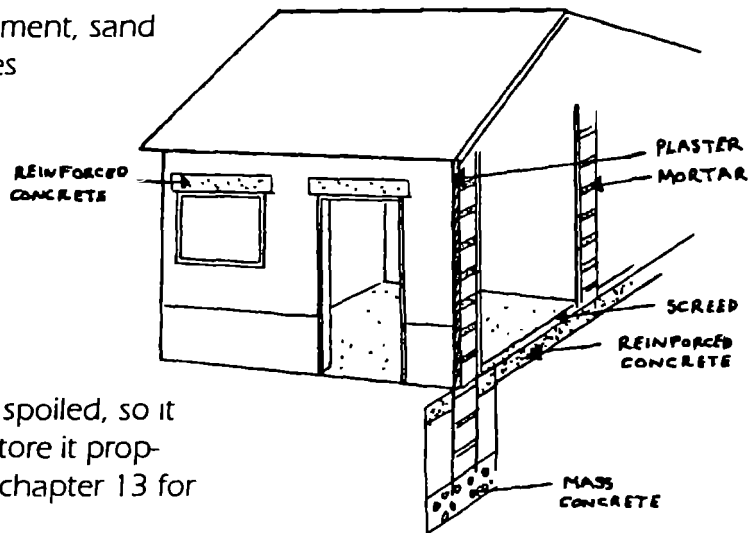

BUILDING SAND

-sand which is quite smooth and fine, a bit like roller meal. This is usually called BUILDING SAND or PIT SAND

-sand which is quite rough, a bit like coarse salt, and is called RIVER SAND.



RIVER SAND

Rough sand makes the strongest mix. Use it wherever possible, but definitely in

- concrete
- floor screed.

Fine sand is more commonly available. It makes a weaker mix, but the mix is easier to work with. Extra cement should be added to the mix to make it stronger. Fine sand can be used in:

- mortar
- plaster.

Do not use sand which

- contains too much silt or clay,
- or is dirty,

Both these weaken the cement

You can test for silt using the following SILT TEST:



-Get a 1/2kg jam jar. Put 5 cm of the sand to be tested in the bottom of the jar.

-In another container mix up one teaspoon of salt in 1/2 a litre of water.

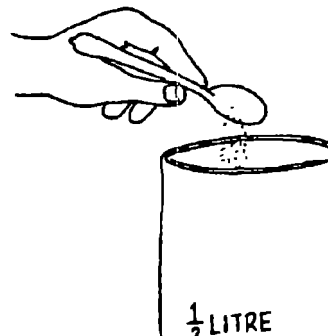

-Pour the salt water into the jar containing the sand until the water covers the sand by about 2.5 cm.

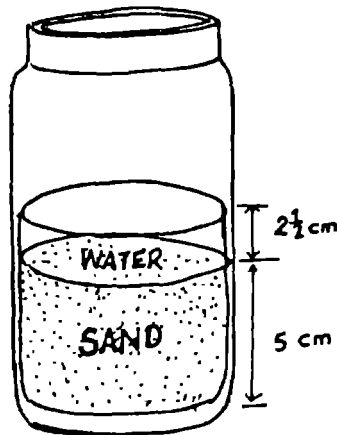

-Cover the jar and shake it well. Leave it to stand for 3 hours until the contents have settled.

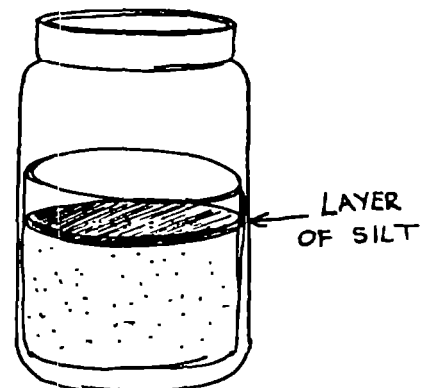

-You should see a layer of silt on top of the sand. If this layer is less than 3mm thick, then the sand should be acceptable to use. If the layer is more than 3mm thick, it contains too much silt.

A quick test for dirt is simply to pick up a handful of sand from the proposed digging site and rub your hands together. If they become very dirty, then the sand is probably too dirty to use without washing it.

(3) Stones

Stones must be broken down to the right sizes, although you may be able to find gravel in river beds for the smaller stones.

The stones must be strong. If they crumble or crush easily do not use them. Concrete will only be as strong as the stones used.

The stones must be clean. Sieve the dust from the broken stones and wash them if they are dirty. Dust and dirt in the stones will make weak concrete.

Round stones will make much stronger concrete than flat stones. Throw away any pieces that turn out flat when the stones are being broken.



GRADING

The strongest mix will contain a good mixture of small, medium and large particles, since the smaller particles fill in the gaps between the large ones. This is achieved by GRADING.

Grading is done by shovelling the sand and stones through a mesh held on a wooden frame - very like a large, flat sieve.



At least two different sized meshes should be used. One to exclude everything larger than the maximum size, one to exclude everything smaller than the minimum size.

MIXING THE MATERIALS

The cement must be mixed with the other materials - the sand, stones and water - PROPERLY and in THE RIGHT QUANTITIES.

(1) Quantities

The mix will be weak if it contains too much sand or too many stones or too much water or too little cement. If too much cement is used, the mix will be hard to work with and expensive

The quantity of each material is called a PART.

Let's say you are making concrete. For concrete, MPU plans say that you should use a 1:2:4 mix. This means it is made up of

1 part cement + 2 parts sand + 4 parts stone

It might consist of.

1 bucket of cement + 2 buckets of sand + 4 buckets of stone.

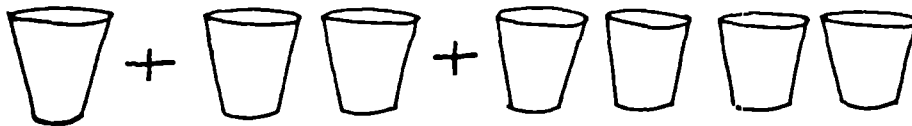

or

1 tin of cement + 2 tins of sand + 4 tins of stones

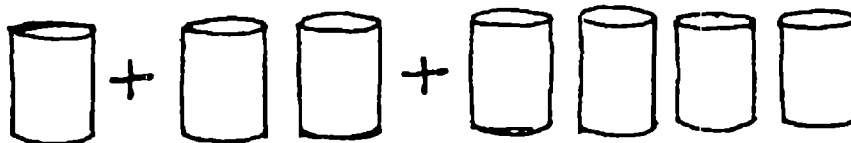

Do you see the important thing here?

Whatever container is used to measure the "parts", it must be the same CONTAINER and VOLUME for each material.

However most builders would mix

1 POCKET of cement+2 WHEELBARROWS of sand+4 WHEELBARROWS of stones

because they **assume** that 1 wheelbarrow will hold 1 pocket of cement. However most wheelbarrows will hold more than a pocket, so measuring this way will mean the quantities are not right

If your labourers insist on using wheelbarrows to measure, you must make sure they follow these steps first

- Put a full pocket of cement in the wheelbarrow.
- Level it and mark all sides of the wheelbarrow.

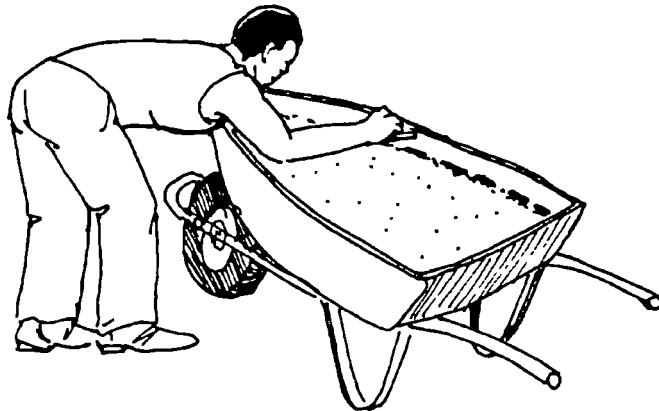

- From then on these marks must be used when measuring from the wheelbarrow. The load must be level when measuring.

However, you must remember to keep a close eye on the labourers. It is easy for them to be lazy and go back to the old way if no-one is watching them

IMPORTANT

Never use an unmarked wheelbarrow for measuring

(2) Mixing

How the materials are mixed and how much water is added will determine the strength of the concrete and how easy it is to use.

IMPORTANT

see
page 65

You should already have made a concrete slab or basin for mixing on. (Read Page 65) Never allow the labourers to mix on bare ground.

The best method of mixing is the THREE TIMES DRY - THREE TIMES WET method.

Three Times Dry

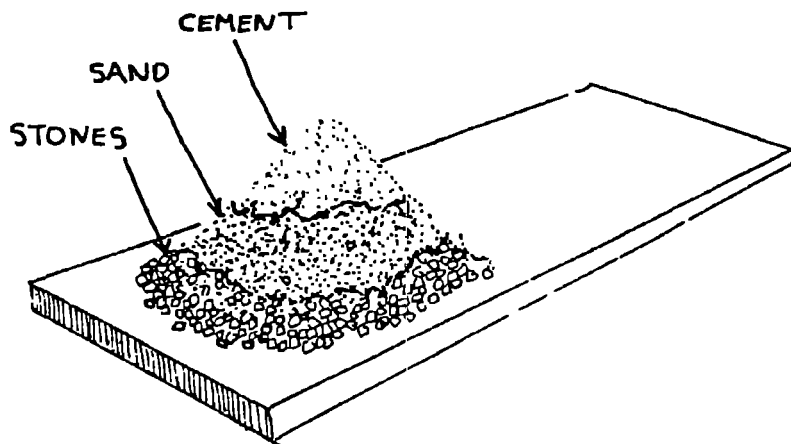

-The measured amounts of stones, sand and cement (in that order) are put in a pile at one end of the mixing slab.

-Two men with shovels should stand facing each other over the pile and turn the whole heap over to form another pile at the other end of the slab.

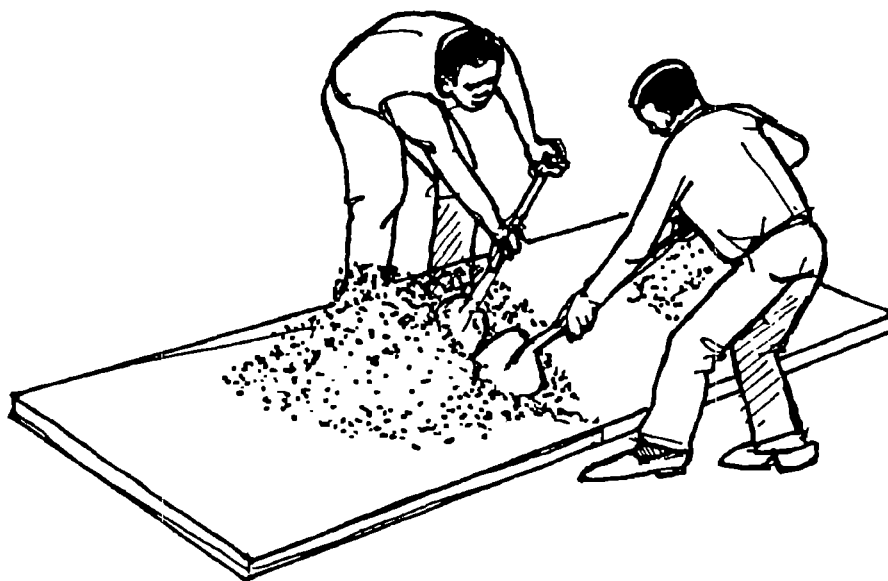

-The mixture being added should run down the sides of the heap.

-This is repeated 2 more times.

This mixture is called the DRY-MIX. The dry-mix should be uniform in colour if it has been done correctly.

IMPORTANT

Never let the labourers add water before the dry ingredients are properly mixed.

Three Times Wet

-The heap of dry-mix is formed into a hollow ring. There should be no mixture left in the centre.

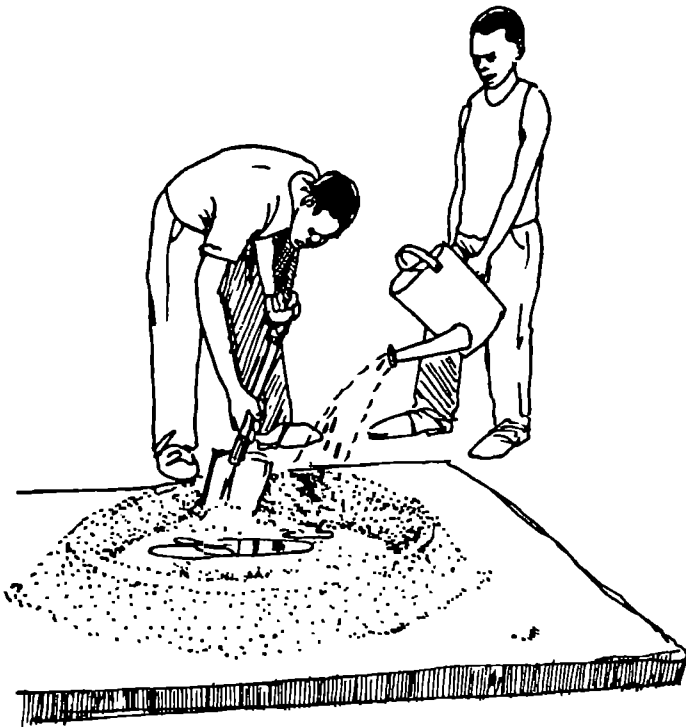

-Some water is poured into the hollow ring.

-The dry-mix is pushed into the water, spreading it out. No water should escape through the ring.

-When all the dry-mix has been heaped in the centre of the slab it will have absorbed all the water.

-The heap is turned over, as with the dry mix.

-This sequence is repeated two more times, adding a little water each time

The labourers must add only enough water to make the mix just soft enough to work with.

The prepared mix should be covered with cement bags to stop it drying out too quickly

IMPORTANT

Many labourers make the mix too wet because it is much easier to work with. This is **WRONG** and the Supervisor must not tolerate it

The Supervisor and Foreman must watch the first batches of concrete, mortar and plaster being prepared, to make sure the labourers know how to do it properly.

The labourers must never prepare more mix than can be used in 30 minutes, since the mix will begin to set after that time.

CONCRETE

Concrete is a mix of water, cement, sand and stones

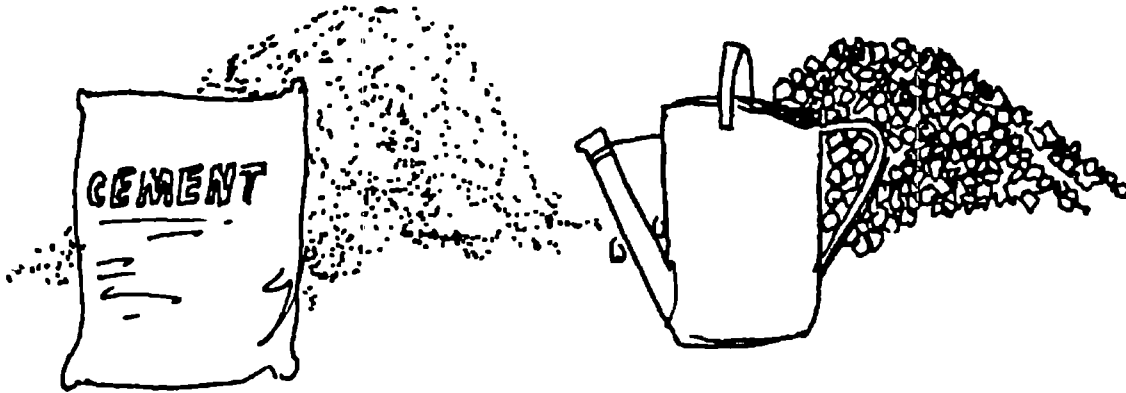

Your buildings will need 2 types of concrete:

MASS CONCRETE:

This is used in the foundation. It can have quite large stones in it - up to a maximum size of 6cm

REINFORCED CONCRETE:

This is used for the floor slab and lintels. Reinforced concrete has smaller stones in it - up to a maximum size of 2.5cm. Metal bars or mesh are put into reinforced concrete to give it strength.

SIZES OF STONES

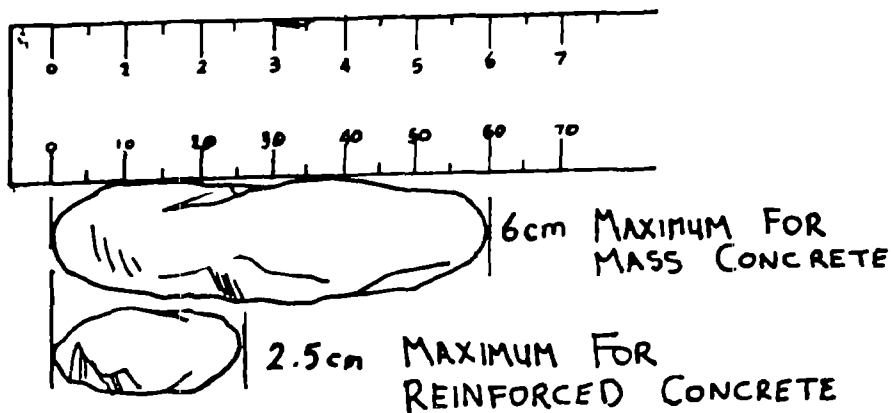

POURING AND COMPACTING

-Concrete should be quite stiff if it has been well made.

-Concrete should always be poured in layers. No layer should be thicker than 100mm.

-Each layer must be compacted with a TAMPER to get rid of any air in the concrete. This makes it stronger. A tamper is simply a heavy weight on a long stick.



CURING CONCRETE

Concrete sets hard because the cement and the water are slowly reacting together. This hardening process is called CURING.

Concrete must be allowed to cure fully before any more work is carried out on it.

Concrete must be kept wet until it is fully cured. If the concrete dries out too quickly,

-the hardening process will stop and the concrete will be weak,

-the concrete will dry too quickly and crack.

Cover the concrete with suitable materials, such as grass, empty cement bags or sand as soon as the surface is firm



This covering must be watered DAY AND NIGHT to stop it drying out.

MORTAR AND PLASTER

Mortar is a mixture of water, cement and sand. It is used to fix bricks firmly in place.

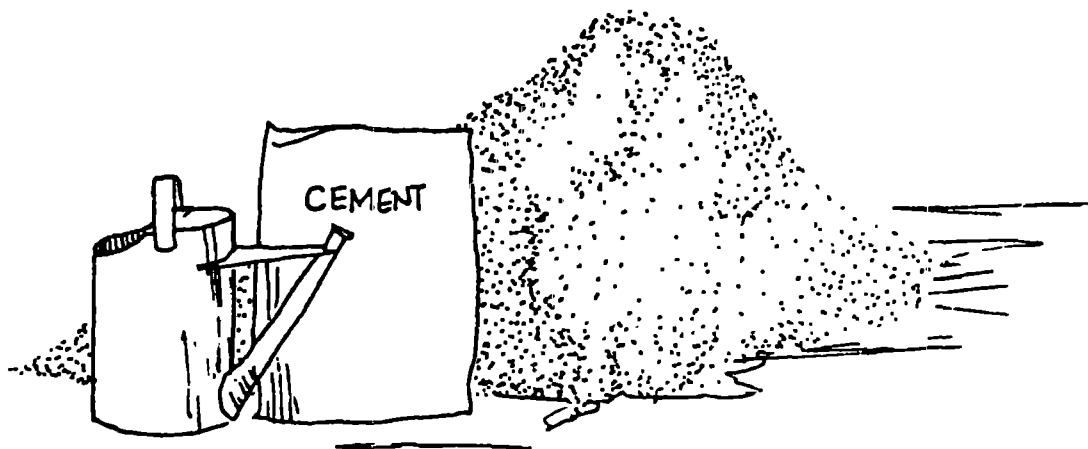

Mortar is also used to cover walls to give them a smooth, waterproof surface. In this case it is called PLASTER

IMPORTANT

the sand used for plaster must be clean. Wash it if necessary

Good mortar should:

- be easy to use,
- harden quickly, so it does not cause delays in building,
- be strong, long lasting and weatherproof.

The experience of the builders is essential in finding the best mix, but as a guide, a typical mix for mortar will be about:

1 part cement + 4 parts sand



Experienced labourers will often replace up to 1/3 of the cement with lime to make a more workable mix. This also helps plaster stick better to the walls.

IMPORTANT

The labourers should use only enough water to be able to work with the mortar. Too much water will weaken the bond

Make sure your Supervisor is at the site when the builders first make mortar or plaster, so he can check they are making good mixes.

REINFORCING MATERIAL

Reinforcing bars and mesh are used in the walls, slab and lintels to give them added strength.

The reinforcement is made of metal and comes in different sizes and shapes. There are 3 main types

CONFORCE:

This is also known as BRC mesh
It is like a wire mat and is used in the floor slab

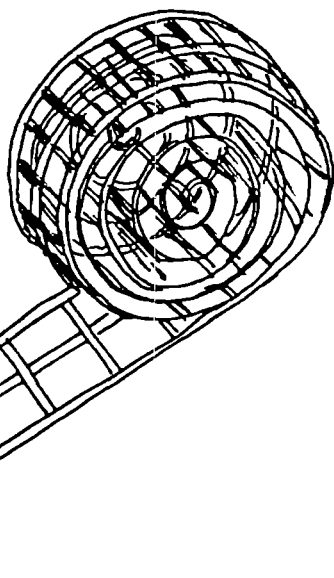
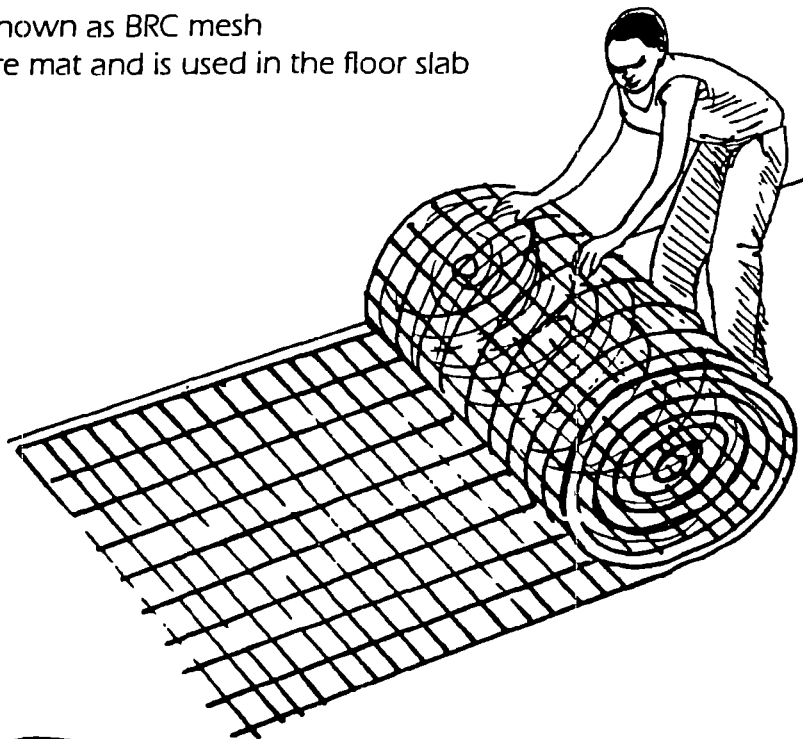

BRICKFORCE:

This is similar to conforce, but is much finer and narrower. Brickforce is used in walls.

REBAR:

This is usually simple metal rods. Rebar is used in lintels

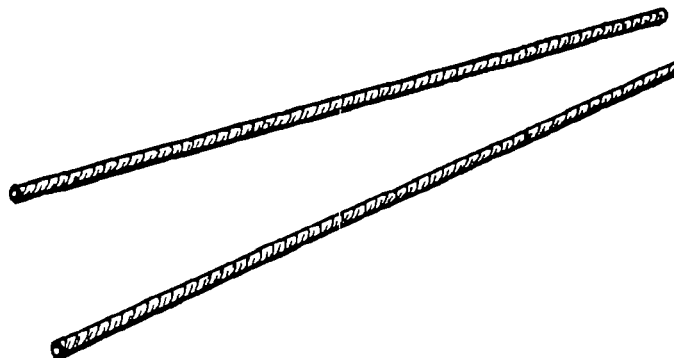

It is important that the reinforcing material is free of loose rust before use.

The reinforcing must be completely embedded in the concrete or mortar where it is used.

Reinforced concrete must be well compacted to get rid of all air pockets. If this is not done, the reinforcing will rust over time and the structure will weaken.

KEY POINTS

- *never use lumpy cement*
- *coarse sand makes a stronger bond than fine sand*
- *test your sand to make sure it is good quality*
- *well graded sand and stone makes the strongest mix*
- *always measure quantities accurately*
- *make sure the materials are properly mixed*
- *NEVER use too much water in the mix*
- *keep concrete and plaster damp while they cure*



Ventilated Improved Pit Latrines

Siting the VIP latrine

Constructing the VIP latrine

Alternative designs

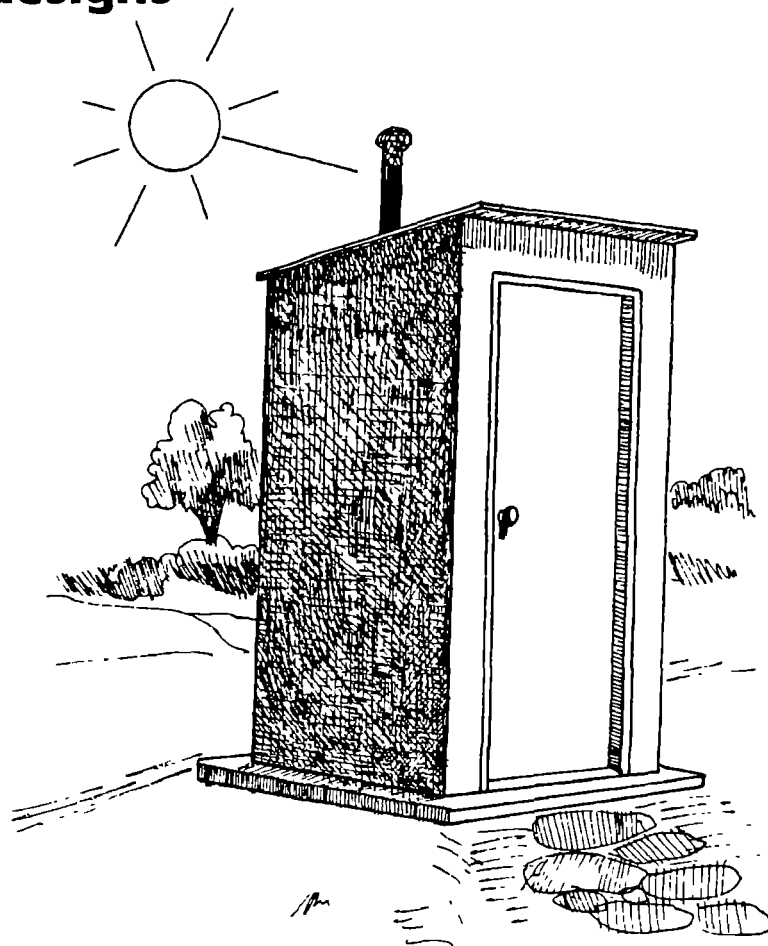

INTRODUCTION

The Ventilated Improved Pit Latrine, or VIP latrine, is probably the simplest structure that you will be building. Consider building some of these as your first target, so that:

- It could demonstrate several important building techniques.
- You could practice following plans.
- You get practice in organising labour.
- You find out how good your local materials are.
- You could see how good your Supervisor is.
- You find out how good your skilled labour is.

You can then use the lessons you have learnt when constructing other, larger buildings.

HOW A VIP WORKS

The VIP is designed to do 2 things:

(1) Not smell.

- The sun warms up the vent pipe and so the air inside the vent pipe gets hotter.
- This causes the air inside the pipe to rise up and out through the top of the pipe. Because the vent pipe goes into the pit, fresh air is sucked down the squat hole.
- This keeps the air fresh, inside and outside the VIP.

(2) Trap flies which would spread disease.

- Flies are attracted down the squat hole by the smells.
- When the flies want to leave the pit they fly towards the light.

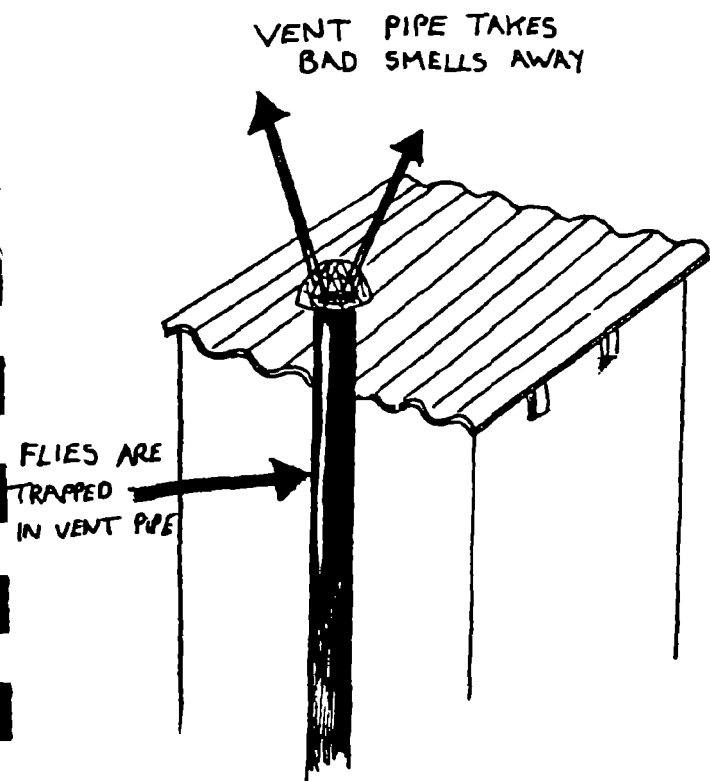

-Since the inside of the VIP should be dark, the only light the flies in the pit can see is up the vent pipe. The flies fly up the vent pipe, are trapped by the mesh at the top and die.

-This stops the flies spreading disease and keeps the inside of the VIP free of flies.

To make all this happen it is important to follow the designs carefully

ACTION

Do not put windows in the VIP, or

Paint the vent pipe black, because

Position the vent pipe on the sunny side of the VIP, so that

Put the door facing the prevailing winds, so that

REASON

the flies will see the light through the squat hole and come out this way.

black absorbs more heat, so the pipe will get hotter and cause the bad air to rise

the pipe gets as hot as possible

the air moves through the VIP correctly.

THE PIT

The pit should be large enough to last a long time before filling up. If it is made according to the plans it should last a family up to 15 years. At a public building, such as a school or health centre, a VIP should last 5-6 years, although it depends how many people are using it.

HOW TO BUILD A VIP LATRINE

VIP's are simple structures, but there is still a lot of detail to follow if they are to work correctly.

Follow each step carefully

(1) Siting the VIP

-Avoid sites with very sandy soil if possible, because the pit is more likely to collapse.

-The VIP must be at least 15 metres but ideally 100 metres from any well. Build the VIP downhill from the well to reduce the chances of polluting the water.

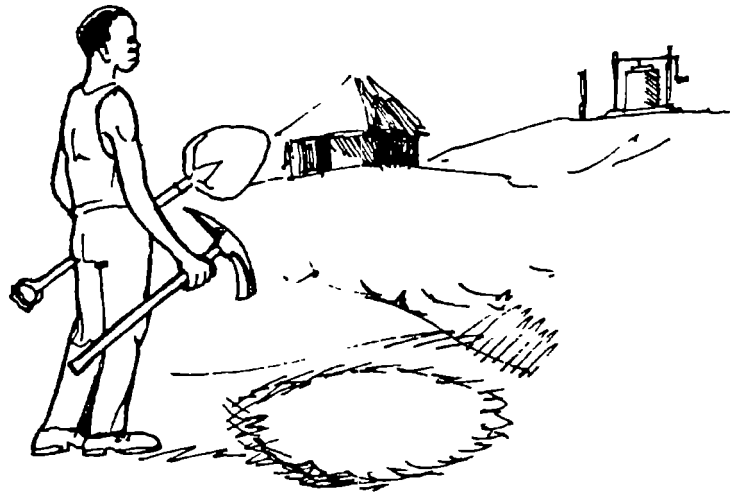

-The bottom of the pit should be at least 2 metres above the water table, even in the rainy season.

-Site the VIP so that the vent pipe is on the sunny side and the door faces the direction of the prevailing winds.

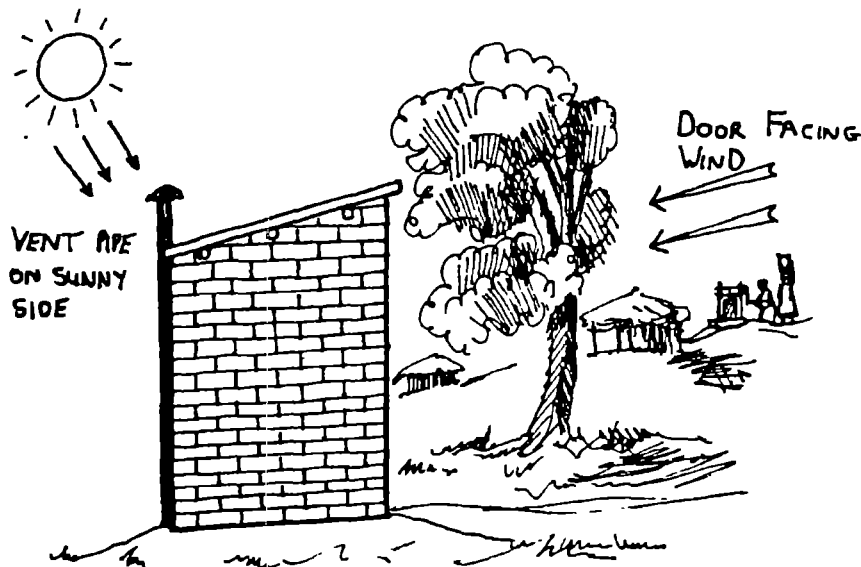

(2) Digging the Pit

- dig the pit 0.9 metres wide and at least 3 metres deep.
- ensure the sides are vertical and will not collapse.



- in unstable soil dig the pit 1.2 metres wide and line it with bricks, built up on top of a 50mm deep ring of concrete. The lining must have holes in it to let liquids soak out of the pit.

(3) The Foundation

The foundation of the VIP has 2 purposes.

- it reinforces the top of the pit, stopping the pit from collapsing,
- it supports the walls of the VIP.
- remove the top soil above the pit as shown in the plans. For a single compartment VIP the hole should be a rectangle, about 2.5 metres long, 1.5 metres wide and 0.3 metres deep. It is not central over the pit.
- in unstable soil, make a 100mm deep ring of concrete around the top of the pit. Build a circular wall on top of this up to ground level.

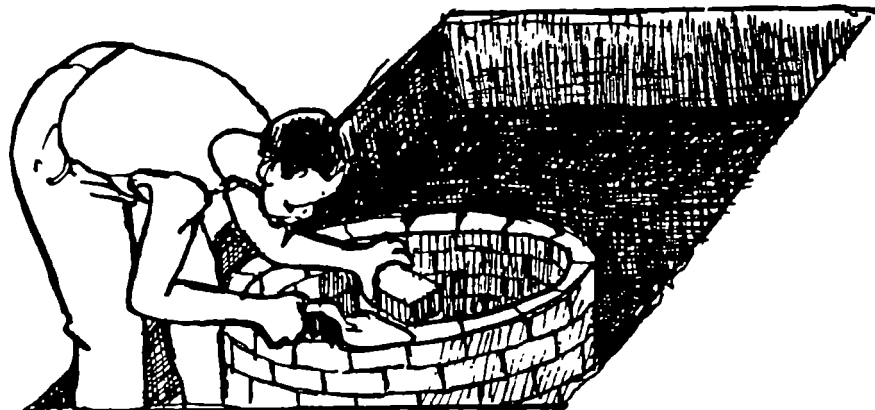

-pack the rectangular hole with hardcore or laterite. Compact it well.

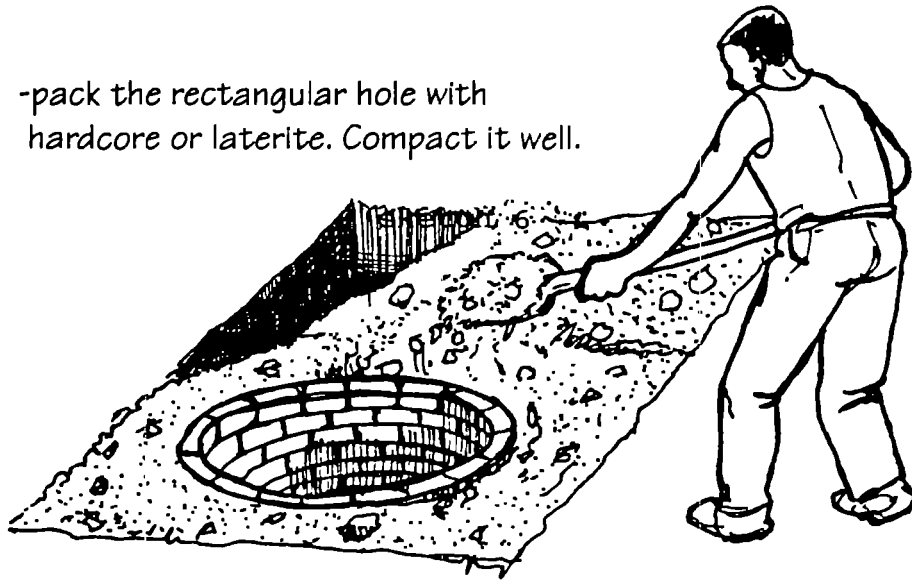

(5) The Slab

The slab is reinforced concrete and supports the main structure.

-you can either cast the slab in-situ over the pit, or make a pre-cast slab and lift it into position.

-there will be two holes in the slab, the squat hole and the vent pipe hole. Block the position of these holes. The vent pipe hole can be made with a short length of pipe. You can make the shape of the squat hole with a damp cement:sand mix (1:10). Leave it to harden overnight.

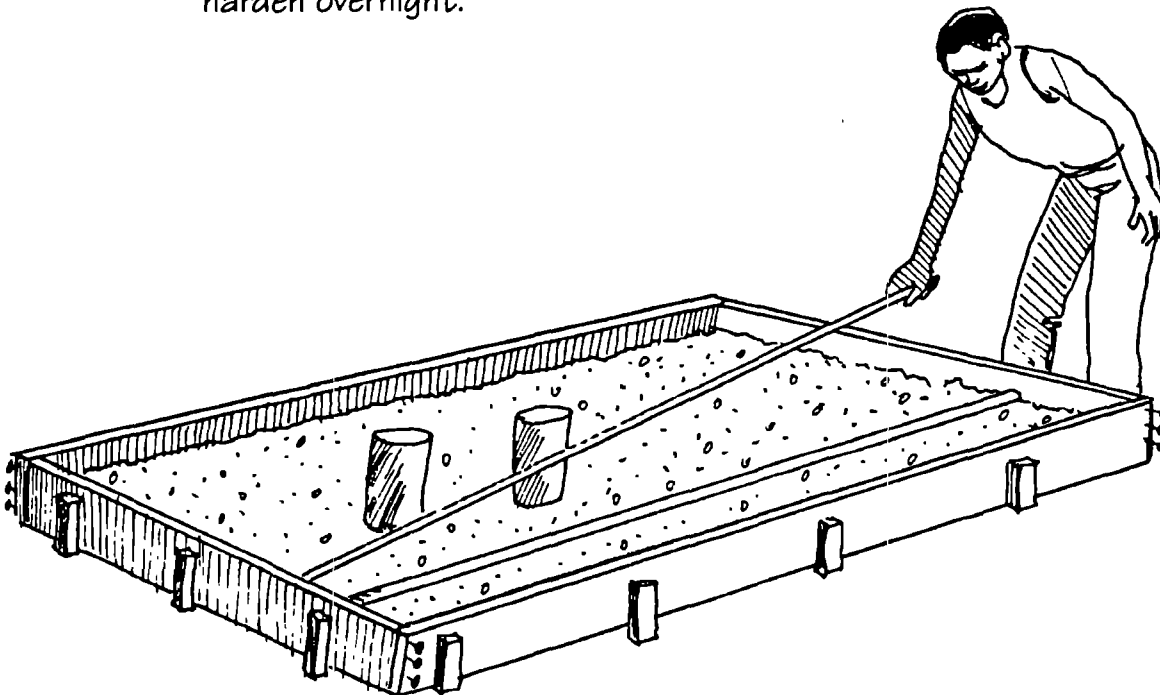

-metal reinforcing bars are required to give the slab strength. The bars should be 10 or 12 mm in diameter. Cut the reinforcing bars to fit the slab.

-prepare the concrete mix. The mix should be 1:2:4 and quite dry.

-pour the concrete into the mould carefully to a depth of 20-30mm. Make sure it fills all the corners and be careful not to disturb the objects put in to make the holes.

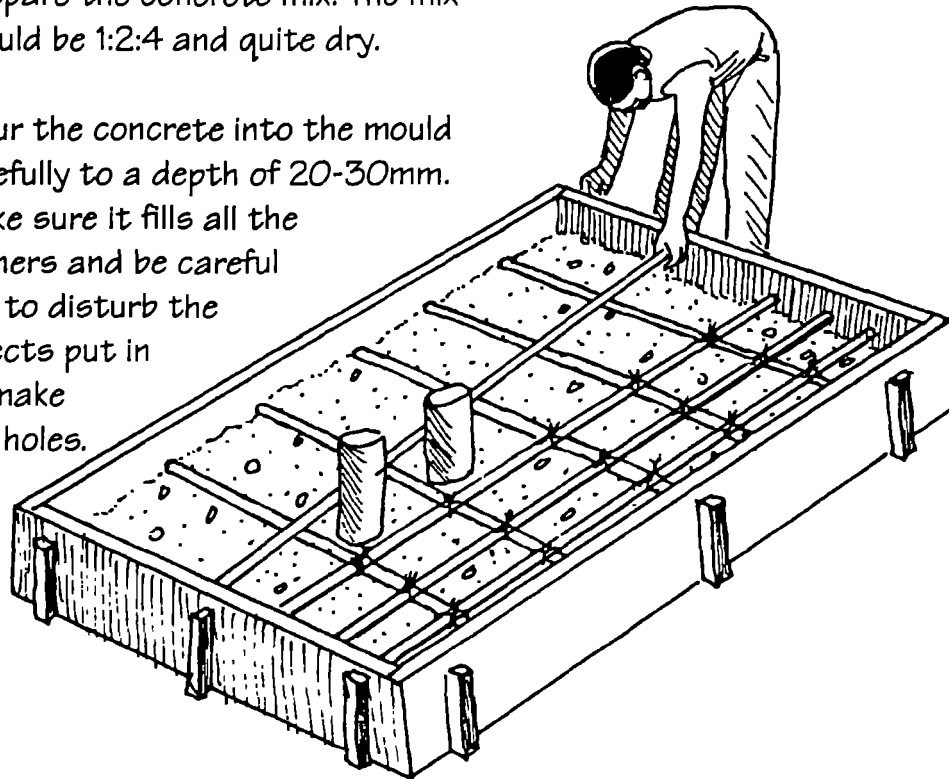

-place the reinforcing bar on the concrete, as shown in the illustration above. The bars should be about 200mm apart. Tie the bars together where they cross.

-fill the rest of the mould with concrete, making a slight depression down to the squat hole.

-compact the concrete using tampers until moisture comes through. This gets rid of all the air bubbles in the concrete.

-smooth and polish the surface to make it easy to clean

-when the surface is firm, cover the concrete with a sand layer about 30mm deep. Leave the concrete to cure for several days, but make sure the surface is kept moist while curing is taking place.

-if you made a pre-cast slab, lift it into position when the concrete is completely cured.

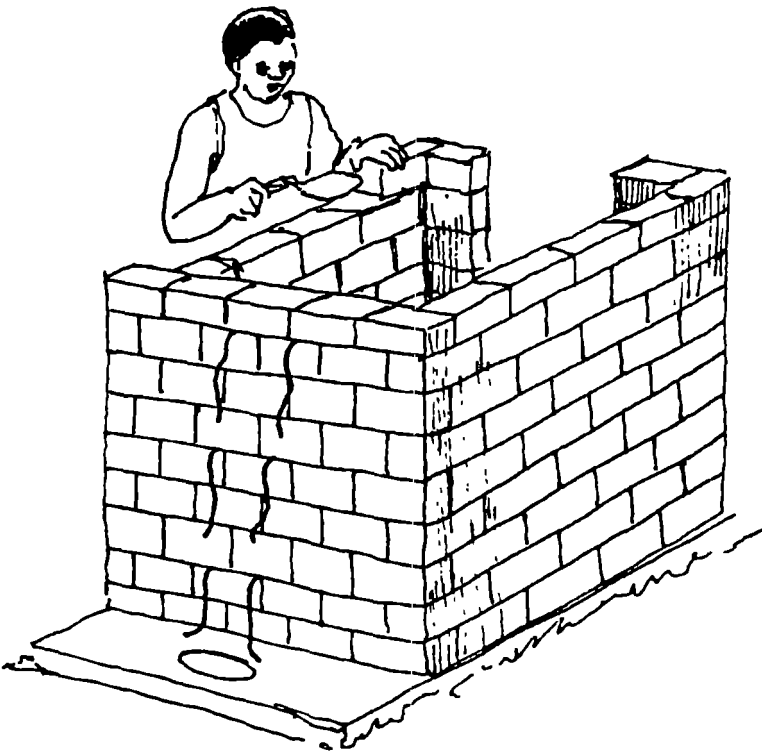
(6) The Structure

-leave the sand layer on the slab. It will protect the surface while the VIP is being completed.

-build the walls of the pit latrine as shown in the plans. Build wire ties into the walls to secure the vent pipe.

-the roof sheets are supported on purlins. Coat the purlins with termite protection, such as creosote, before fitting them. The roof should slope from front to back.

-plaster the walls and whitewash the outside of the VIP with a lime and cement mix. By adding 1 part of cement to 9 parts of lime the whitewash will last much longer.

(7) The Vent Pipe

-the vent pipe should be long enough to extend at least 500mm above the highest part of the roof.

-metal or asbestos pipes should have an inside diameter of at least 100mm. Brick vent pipes should be 200mm square and the inside should be smoothly plastered.

-paint the vent pipe black.

-remove the blocks used to make the holes and place the vent pipe in position. Secure the vent pipe to the wall with the wire ties.

-make sure the joint between the vent pipe and slab is well sealed, to stop flies and bad air escaping.

-fix a fine mesh fly screen over the top of the pipe. This is VERY IMPORTANT. The mesh traps the flies, preventing them from escaping. Use nylon mesh if possible, since this will not rust.

-break open the squat hole and brush the floor clean.

The VIP is now complete and ready to use.

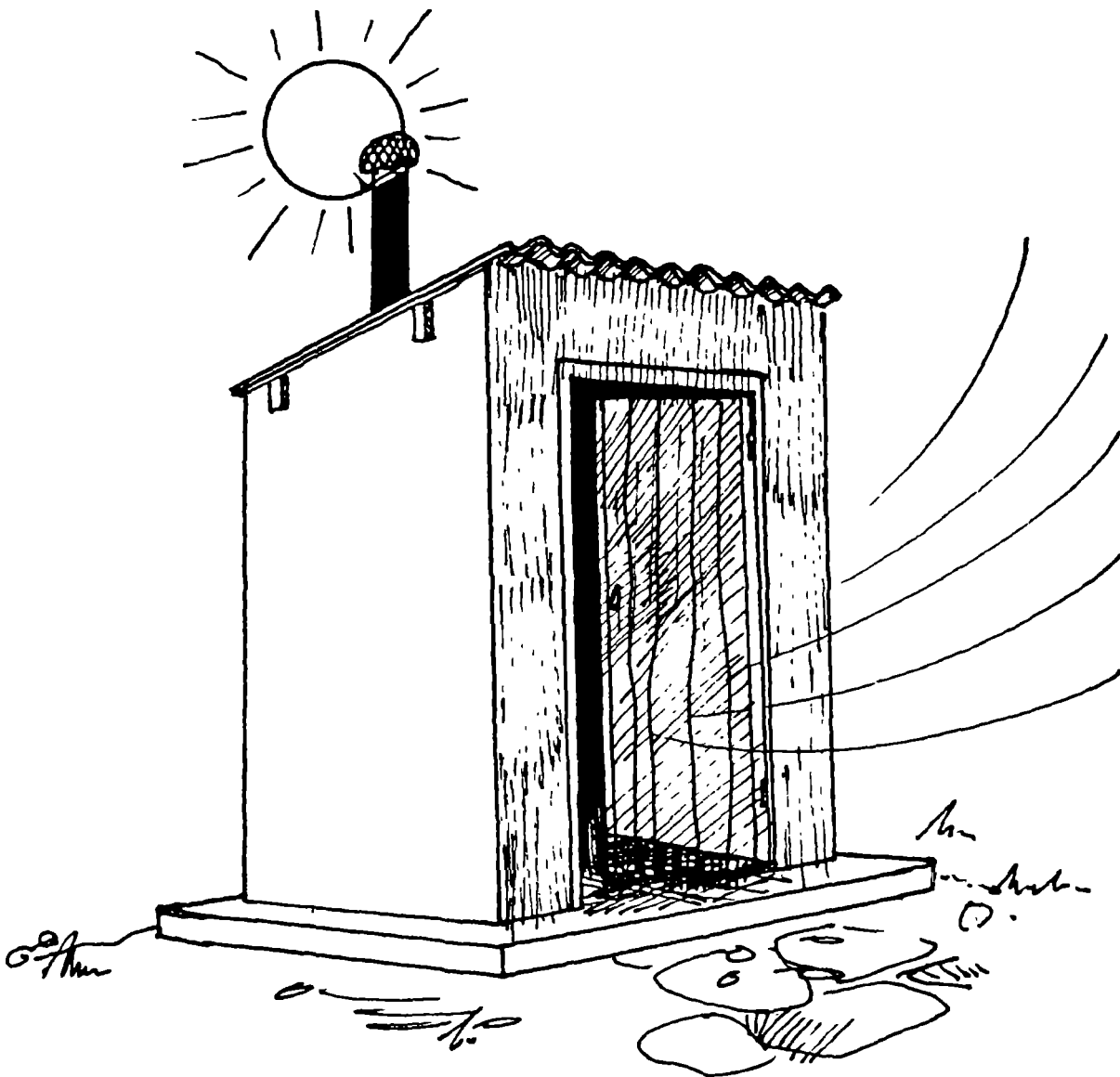
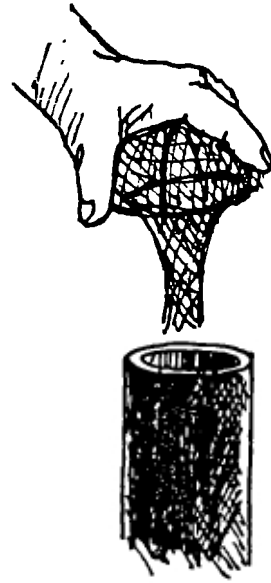

ALTERNATIVE DESIGNS

There are several different types of VIP:

- single and double compartments,
- with and without doors,
- double pits and so on.

Ask your Regional Officer about these and decide which is the most suitable type for your project.

(1) Urban Areas

If your project is in a densely populated area, or if you are very near a well or water source, you may have to make a solid pit lining. Some Councils have equipment that can pump out the contents of the pit when it becomes full.

If your project is in an urban area, have your plans approved by the Council.

(2) Extra Light

The inside of the VIP must be dark and some people, especially children, may not like using them. If the standard design is not popular in your area you can consider putting in a window or opening, provided you include one of the following modifications.

(a) Put shutters on the opening. When someone uses the VIP they can open the shutter to let in more light. They **MUST** close the shutter when they leave the VIP or flies will come out of the squat hole.

(b) You can have openings without shutters, provided you make a cover to go over the squat hole. Have a long handle on the cover so it is easy to move. The user **MUST** replace the cover whenever they have finished and the cover must be a good fit to prevent the flies being attracted by the light.

Remember, if you use either of these methods you must educate the users to close the shutters or replace the cover when they leave the VIP.

(3) Other Changes

You can make other changes to the VIP to suit local preferences. For example, you can mould small platforms on the slab to stand on. Make the shape of the squat hole to suit yourselves. You can even build the hole up into a seat, like a flush toilet.

Choose the design which is most appropriate to your project, but educate the community about how to use the VIP properly

KEY POINTS

- *keep VIP's as far away from wells as possible*
- *make sure the pit is deep and stable*
- *reinforce the slab*
- *do not put windows in your VIP*
- *put the vent pipe on the sunny side of the VIP and paint it black*
- *have the door facing the prevailing winds*
- **ALWAYS** *cover the vent pipe with mesh to trap flies*



The Site

Selecting the site

Preparing the site

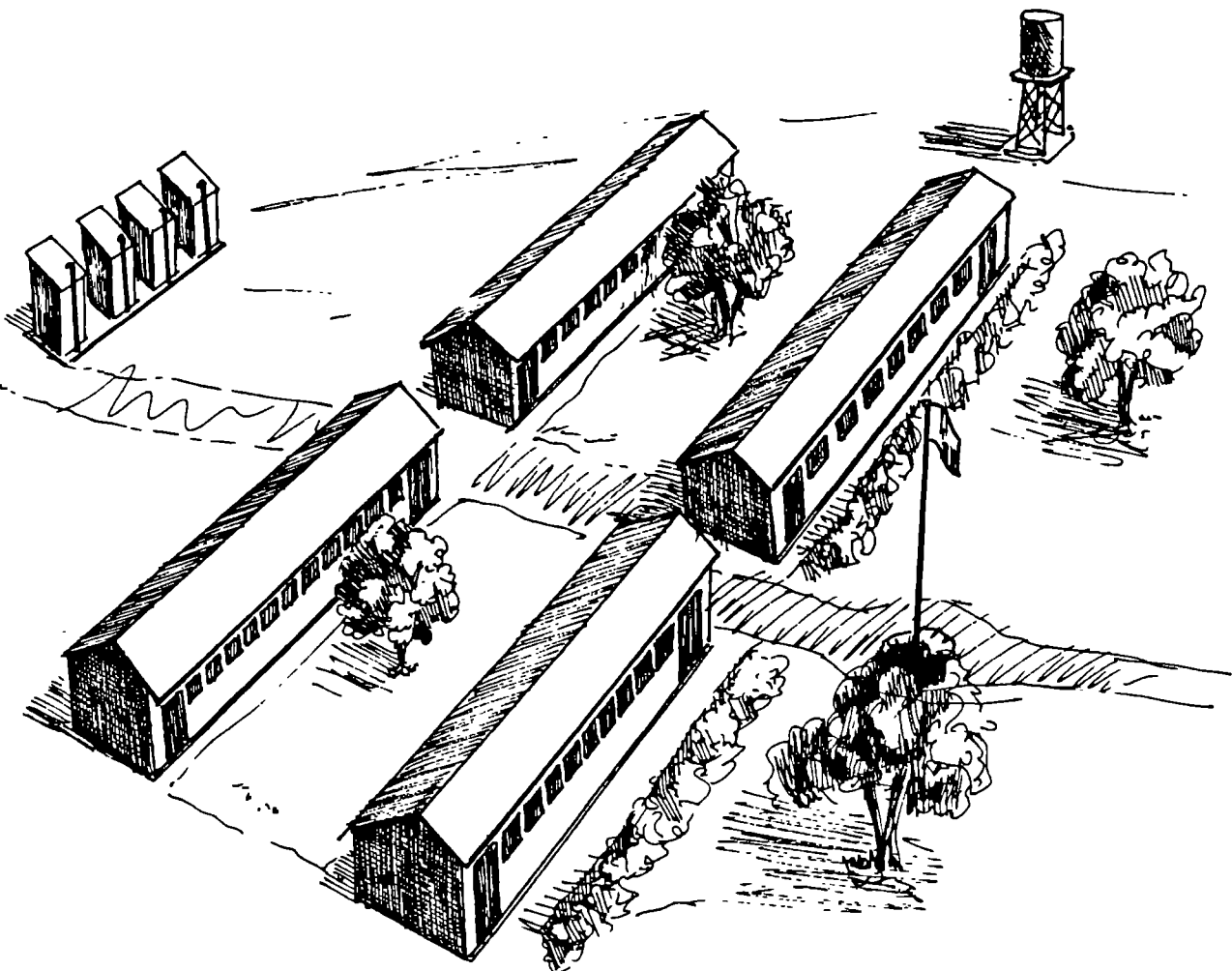

INTRODUCTION

If you are in a Boma, you may have had to get planning permission for your project. In this case you will already have a plan of where to put your buildings. You cannot change this easily.

If you do not have an officially agreed plan, this chapter gives you some things to consider when deciding exactly where to build.

Take a little bit of time now to decide the best PLACE and DIRECTION for your buildings. This should make them more pleasant to live and work in.

Make sure the entire community is involved in these decisions. It is EVERYONE'S project.

Your Supervisor should draw plans of your site and where you intend to construct new buildings. Make sure these drawings are approved by the Council before you start construction.

SELECTING A SITE

Look at the following things:

see
page 79

- 1. Soil** -the soil should be firm Buildings constructed on loose sand or clay will require stronger, more expensive foundations (SEE PAGE 79)

-Avoid very rocky soil, or it will be difficult to dig the foundations

- 2. Level** -Try to find a level site. It will save work later.

- 3. Trees** -trees provide shade from the sun, shelter from the wind and their roots stop the soil being washed away in the rains. Try to site your buildings so that you do not have to cut down any trees.



-Site your buildings at least 5 metres away from any tree. If it is closer than this, the roots may damage your building

Trees such as Eucalyptus demand a lot of water. Increase the distance to 1.5 times the height of any water-hungry trees. If you do not do this, the trees will take water from the soil under your buildings. This can make the foundation crack.

- 4. Other Buildings** -think about where you site your new buildings in relation to existing ones. The existing buildings can shelter the new one from the wind.

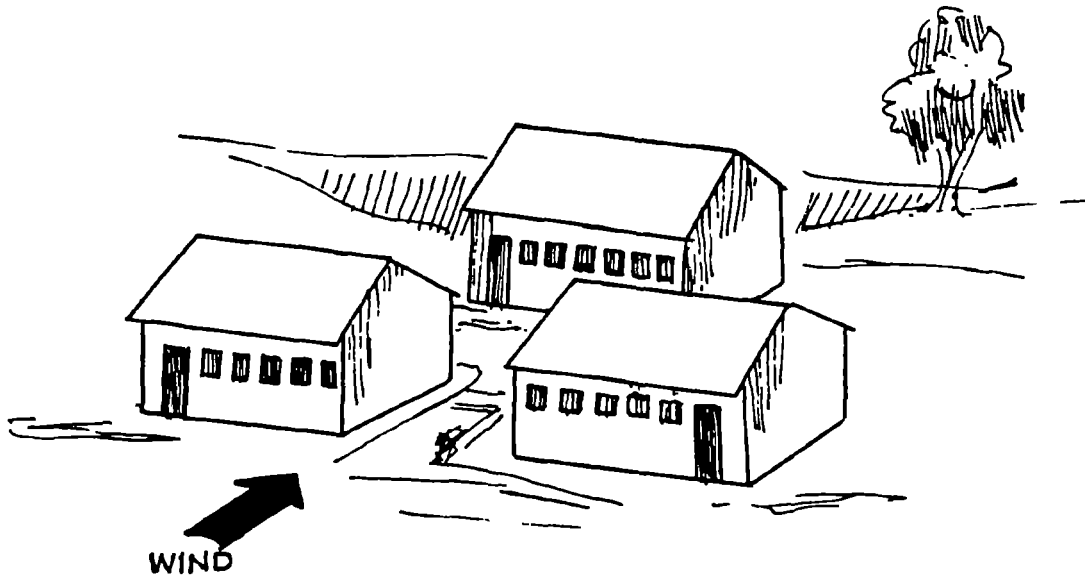

DIRECTION

Once you have decided where to put your building, you can decide which direction it should face. Think about the following things:

- 1. Wind** -If the short sides of the building point in the direction of the wind, less wind and dust will blow into the building

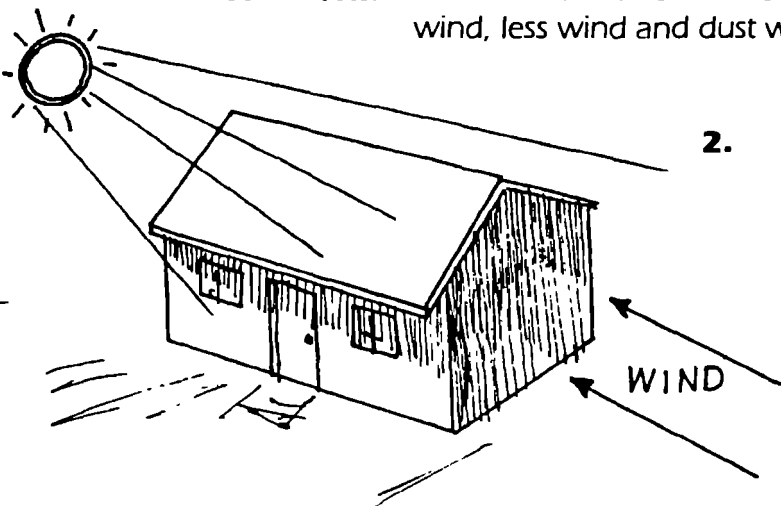

- 2. Sun** -Do you want morning sun or afternoon sun? Morning sun will heat the building faster in the cold season

- 3. Other Buildings** -Think about the view from your windows. If there are other buildings near by, do you want your house, classroom, etc, to look directly at them or not.

Of course, it will probably not be possible to satisfy all these considerations. Decide which are the most important to you.

CLEARING THE SITE

Before construction begins the building site must be cleared.

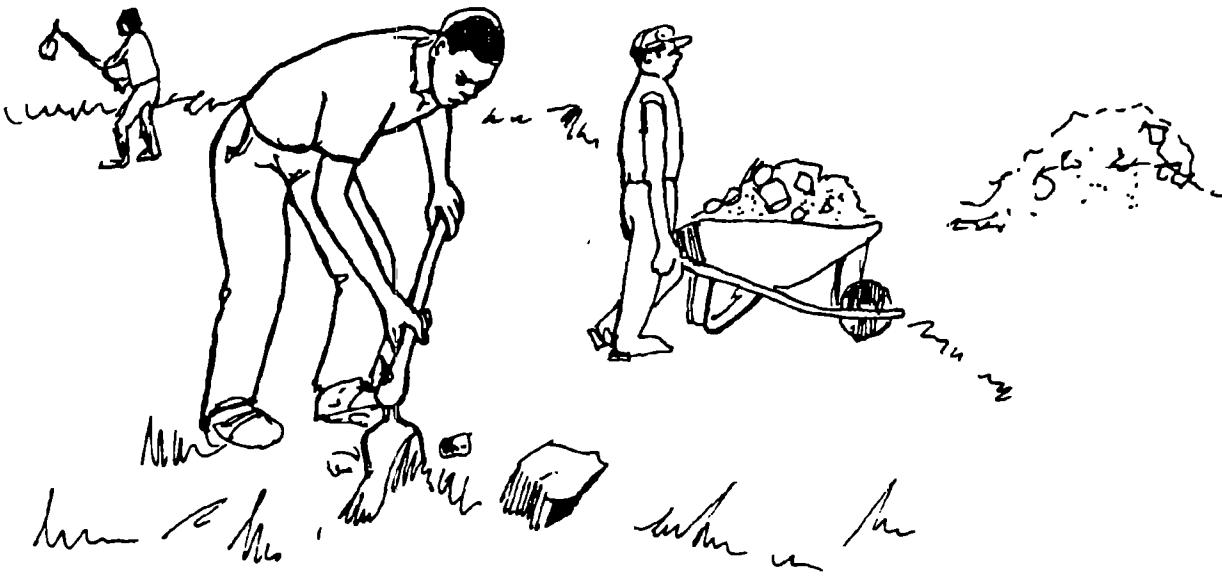

-Cut down long grass.

-Remove any large stones.

-If you have to cut down any trees, stump them out completely or they may cause problems in the future.

Then make sure everything is ready for the start of building.

Three things are important:

- 1. WATER:** Builders require a constant supply of water at every stage of building, so make a water pit and keep it full. If the builders run out of water it will delay the building.

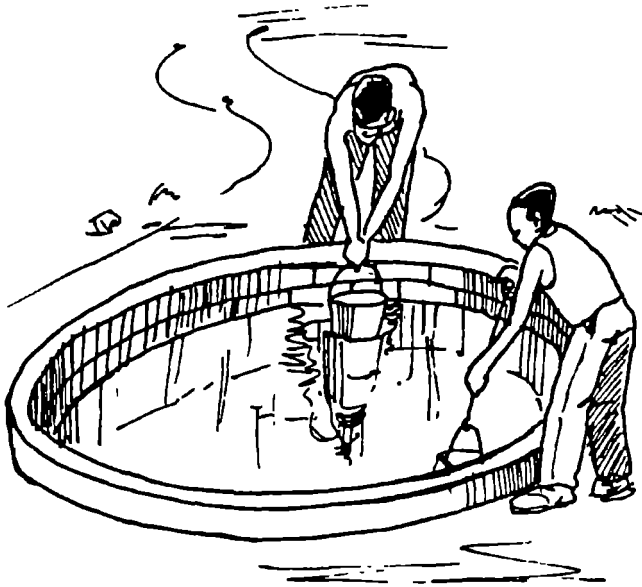

The water pit should be at least 1 metre in diameter, 1 metre deep and have a small wall around it to stop dirt, leaves, etc, from making the water dirty. The pit must not leak.

- 2. MIXING:** Lay a slab for mixing concrete and mortar on. Make sure it is kept brushed clean of grass, dirt and leaves. ALL the concrete and mortar must be mixed on this slab. This way the mixes can be made clean and strong. NEVER let labourers mix on bare ground.

Make the slab at least 1.5 metres by 2 metres, so that it is big enough for the builders to work on.

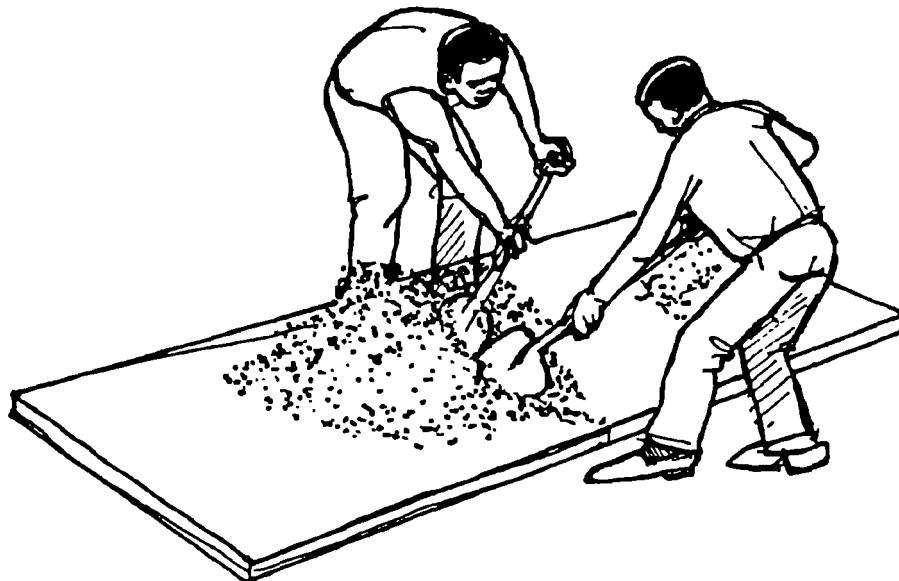

If your building site is large, make one slab for each construction area. This will reduce the amount of carrying required.

- 3. PATHS:** Paths around the site make moving things much easier, whether carrying things by hand or in wheelbarrows.

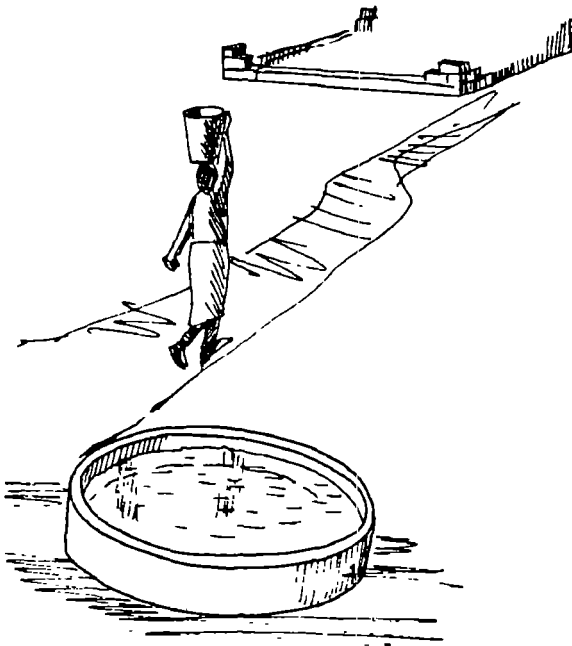

Make paths between these areas.

- the water pit,
- the mixing slab,
- where any material is stored,
- each place where building will be done.

KEY POINTS

- choose a site which has firm soil and is as level as possible
- try to chop down as few trees as possible
- make sure you have made a water pit and mixing slab BEFORE building starts
- clear the site and make paths where necessary

Setting Out

The importance of setting out

How to set your building out accurately

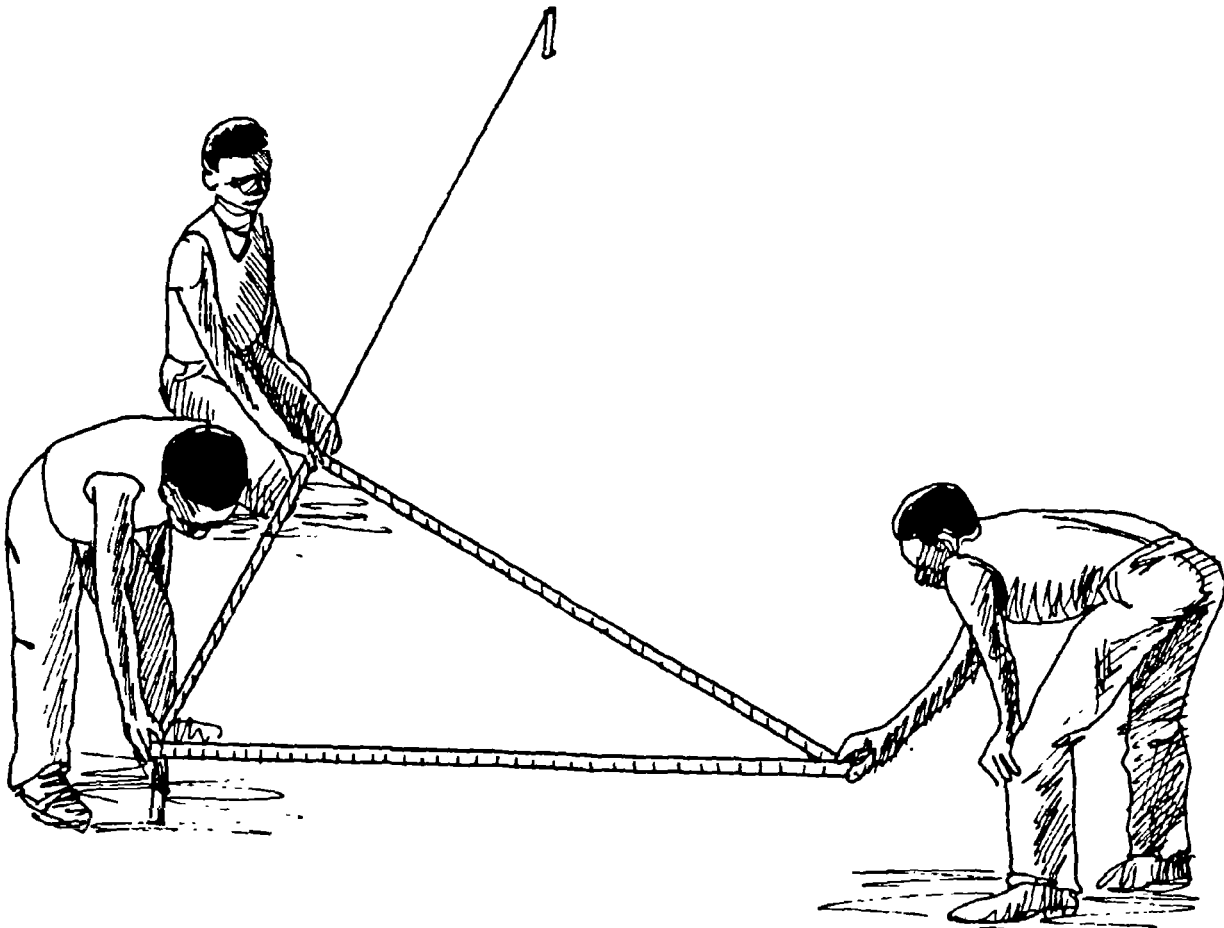

SETTING OUT

Setting out means marking the positions where the foundation trenches for all the walls of the building will be dug

Everything else will depend on the setting out being accurate

The entire foundation should be set out at one time, rather than over several days.

IMPORTANT

The Supervisor should do this job personally, with one or 2 assistants.

Always use proper building line. This will not stretch or break easily

PREPARATION

The area to be set out must be completely cleared. Grass should be cut down and any stones or roots removed.

The topsoil should be removed down to a depth of at least 150mm, or until firm, undisturbed soil is reached

PROFILE BOARDS should be made in advance. They should be wider than the foundation trench. Look at the illustration on page 73 to help work out how many will be required

see
page 73

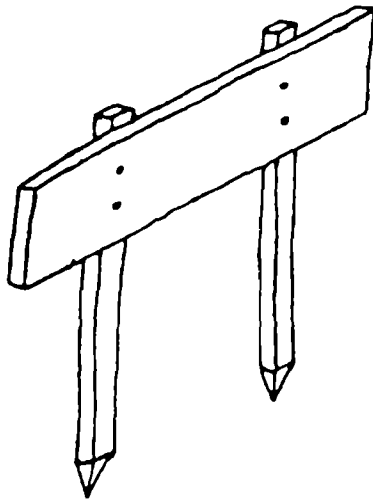

ACCURACY

The setting out **MUST** be accurate.

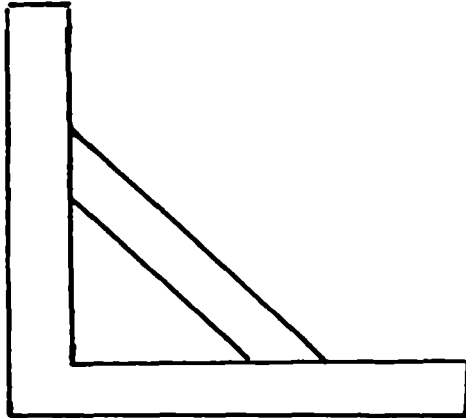

Every corner must be square. That means being at a right angle (90 degrees).

If the corners are not quite square it will cause problems at every stage in construction.

There are a number of ways to ensure the layout is square. One of these is the 3-4-5 method.

IMPORTANT

The supervisor must check and double check every angle and measurement personally.

THE OUTSIDE WALLS

The front of your building is marked out with a length of building line between 2 pegs. One peg marks one corner of the building.

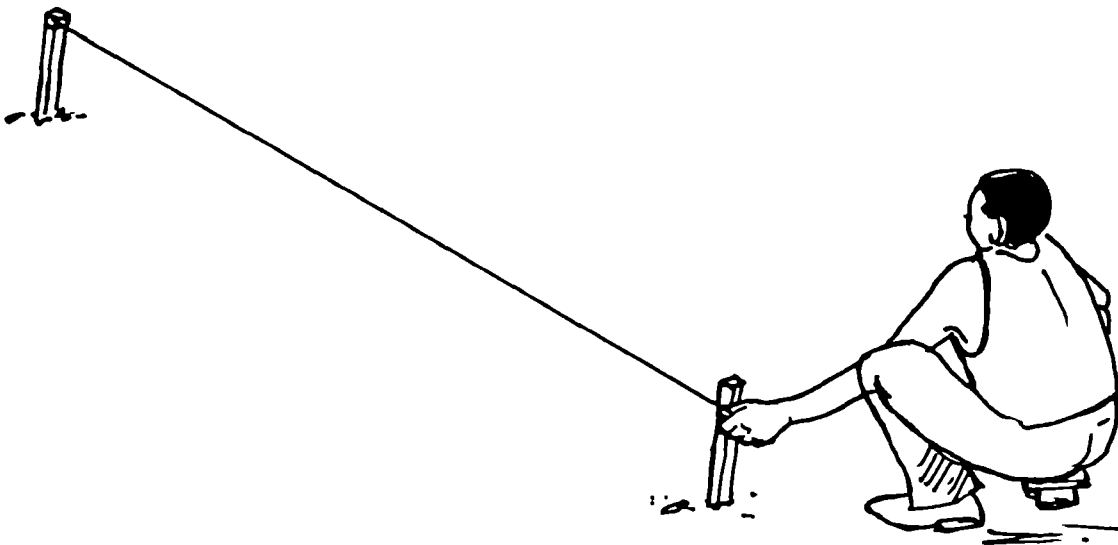

A line is put in from this peg to represent one end of the building. This line should be as square to the first as possible.

Now the 3-4-5 method is used to make this corner exactly square

The 3-4-5 Method:

In a triangle with sides that are exactly 3 metres, 4 metres and 5 metres long, the angle between the short sides is exactly 90 degrees

-The people setting out should use a 50 metre tape measure.

-The man marking the side of the building holds the end of the tape.

-The man at the corner peg holds the 3 metre mark at the peg. This means they are exactly 3 metres apart.

-A third man holds the 7 metre mark of the tape on the line marking the front of the building. This means the second and third men are exactly 4 metres apart.

-The first man also holds the 12 metre mark of the tape. He adjusts the 2 ends he is holding until they touch and tape is tight. This means the distance to the third man is exactly 5 metres.

-The first man marks the exact point where the 2 ends of the tape meet and puts a peg in. Since the tape has made a 3-4-5 triangle, a line connecting this peg to the corner is exactly square to the front line of the building.

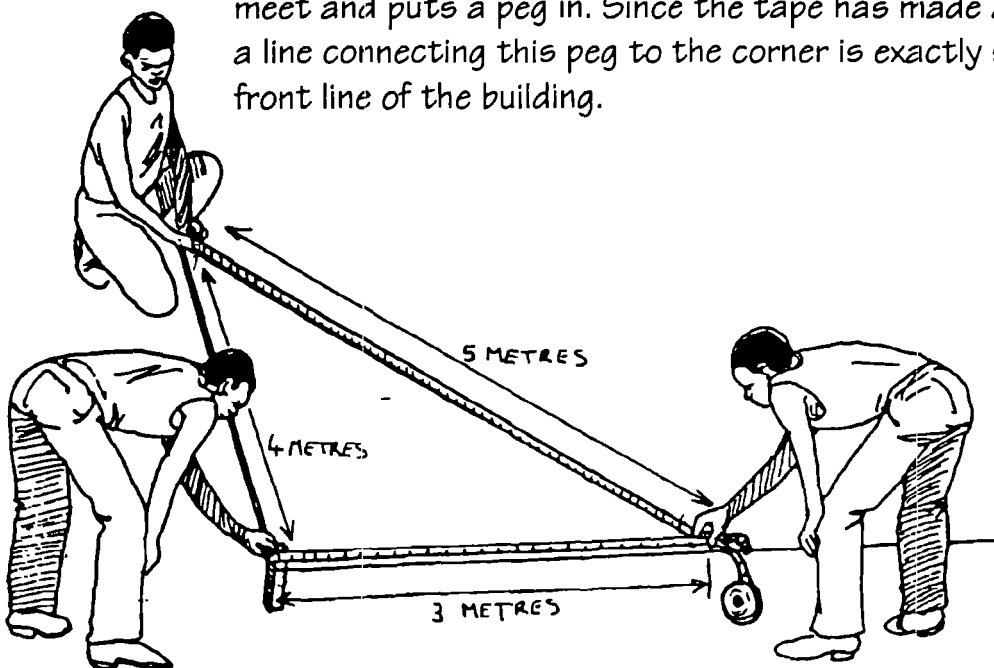

This is the front and one side of the building.

This procedure is repeated for the other walls.

When all lines are in for the outside walls, the Supervisor must double check that everything is square.

He does this by measuring the distance from each opposite corner, as shown in the sketch.

If these 2 distances are the same, then the building should be square.

If these 2 distances are not the same, the person setting out the building has made a mistake. Do not take anything for granted. Check and double check. Correct where necessary.

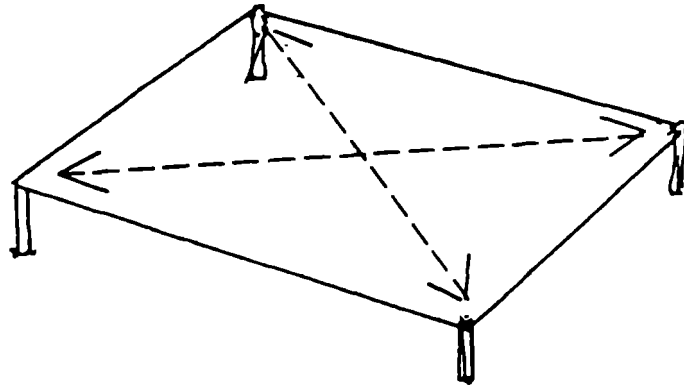

PROFILE BOARDS

The profile boards are firmly fixed about 3 metres outside the lines of the building. They are used to ensure the accurate measuring and setting out work which was done will be preserved.

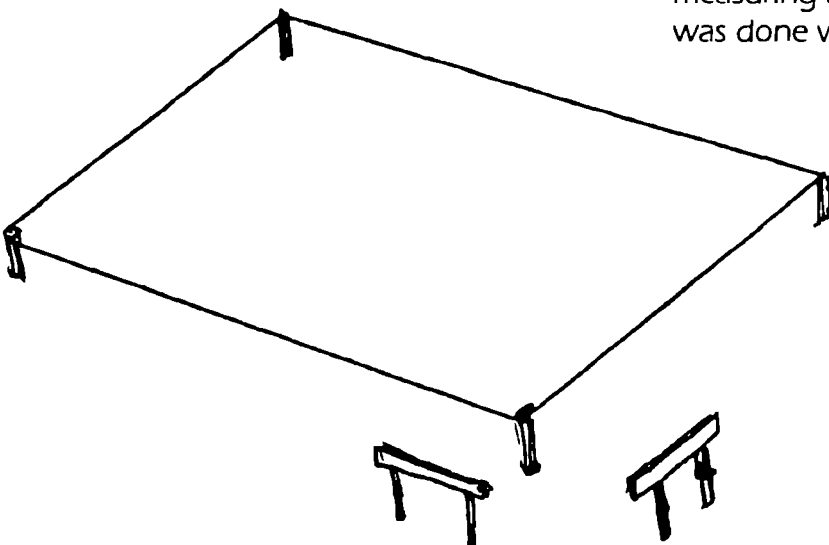

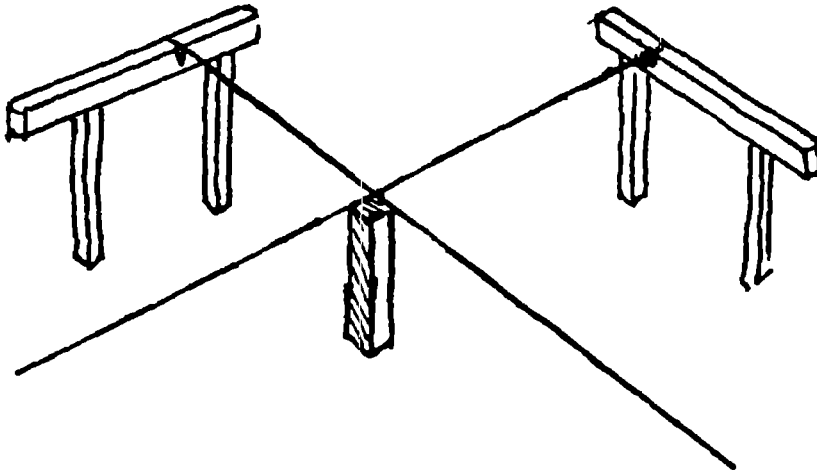

A saw notch is put in the board in line with the main lines of the building.

Other notches are put in to mark the width of the wall and width of the foundation trenches. The trenches should be about 3 times as wide as the foundation wall.

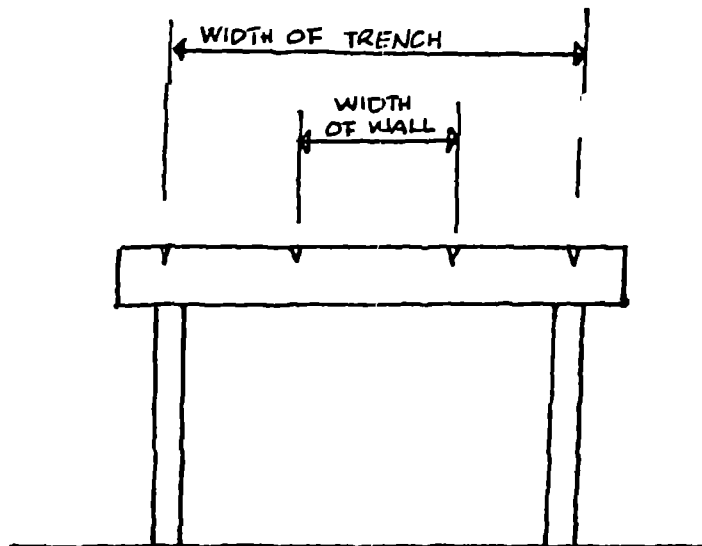

INSIDE WALLS

Lines are now put in for the inside walls, following the same procedures as for the outside walls.

Profile boards are also put in to mark the inside walls.

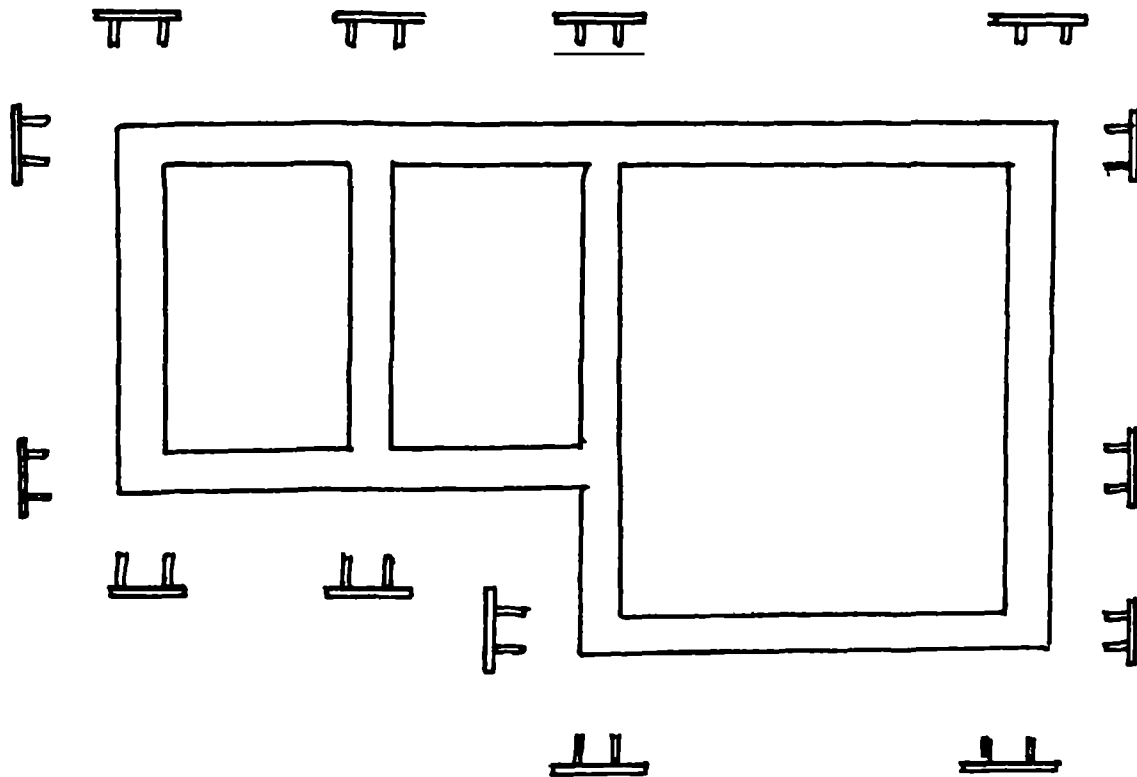

BUILDING ON A SLOPE

When building on a slope the trench has to be dug in level steps

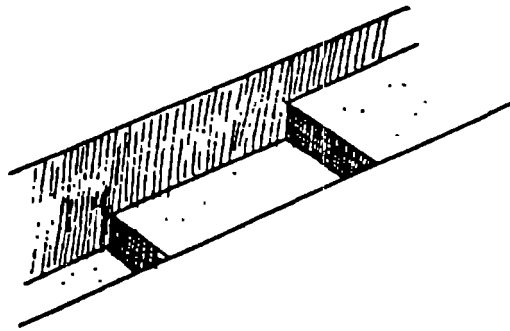

The size of the steps must be as deep as one or two courses of brick or block. This will keep the courses level.

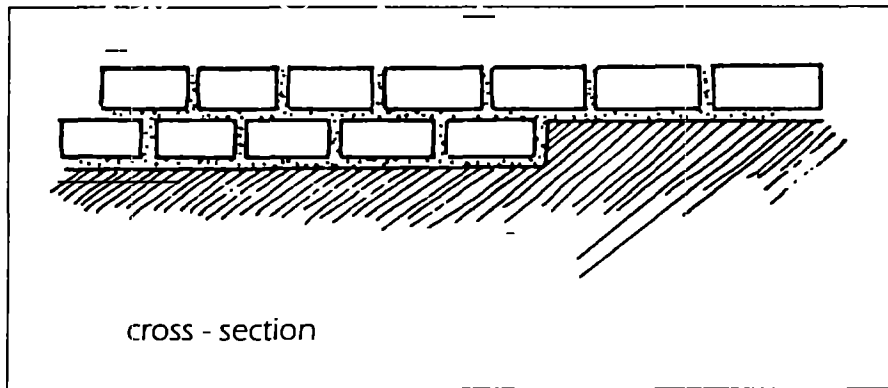

KEY POINTS

- the Supervisor is personally responsible for setting out
- setting out **MUST** be accurate
- all angles and measurements must be checked and double checked

Foundations

Digging the foundation trenches

The footings

The foundation wall

Backfilling

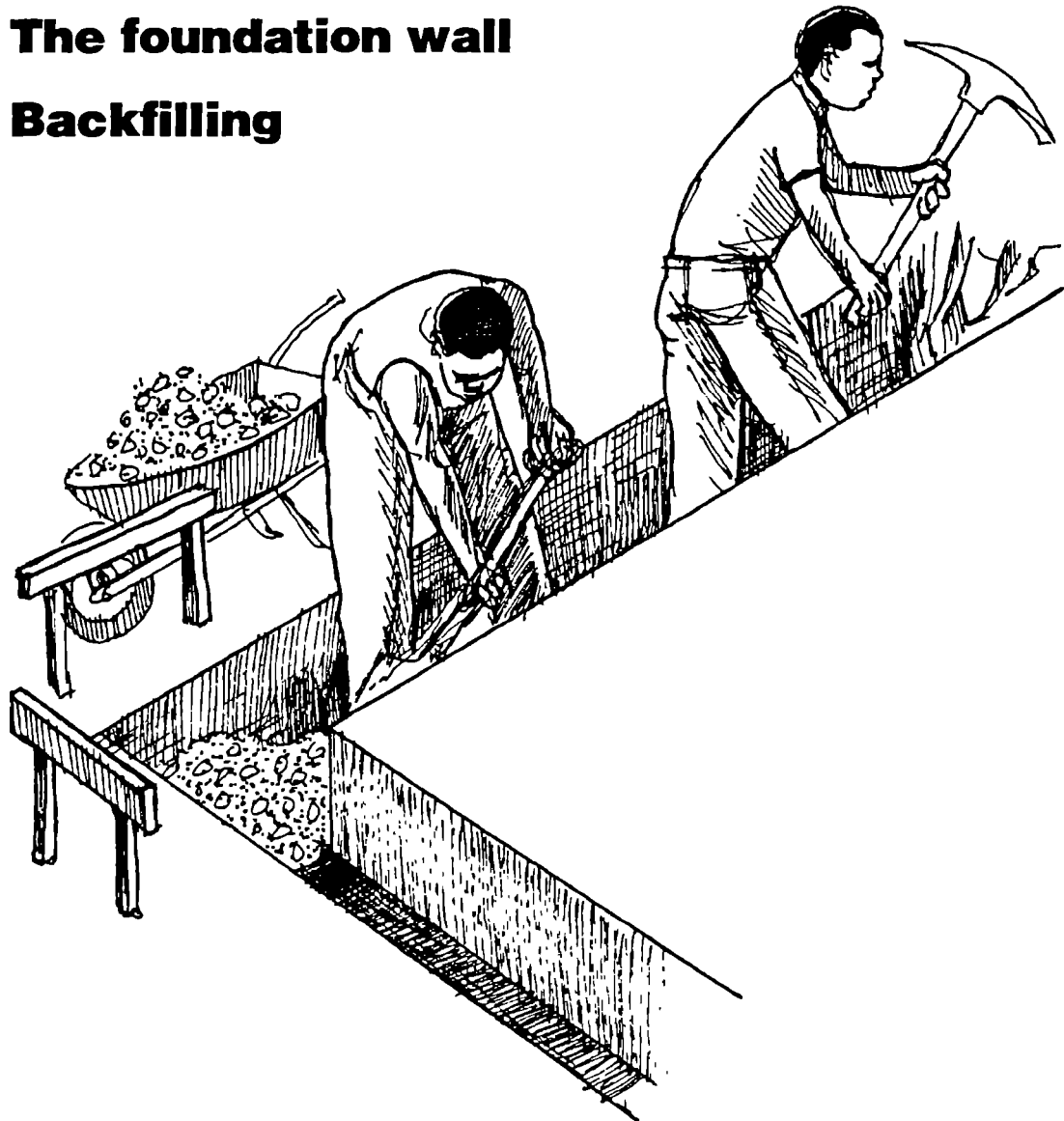

INTRODUCTION

The foundation is the most important part of any building. It must be strong enough to support the entire weight of the building.

The soil under the surface of your site be firm and solid. Soil which contains a lot of loose sand or clay is not strong.

see
page 79

If you have to build on weak soil, especially black Mopani clay or loose sand, extra work will be required to make the foundations strong. This is explained on page 79.

If this is the first time you have built large buildings on the type of soil in your area, ASK ADVICE.

Examine existing buildings at the project site. If they have serious cracks in the walls, then it is possible that the soil in your area is not strong and the building has sunk slightly into the ground. This is called SUBSIDENCE.

Make sure your Regional Officer and Buildings Officer are aware of any cracks. Ask your Supervisor his opinion BEFORE starting any building work. It is better to plan ahead, rather than try to correct problems later.

WHAT IS A FOUNDATION

The foundations are made up of different parts (look at the two illustrations on the opposite page)

- the FOUNDATION TRENCH
- the FOOTINGS, which is a layer of concrete in the bottom of the foundation trench.
- the FOUNDATION WALL, which are the bricks or blocks that you lay in the foundation trench.
- BACKFILL, which is the laterite or hardcore used to fill up the foundation trench. The backfill must be well compacted and treated with ant poison.

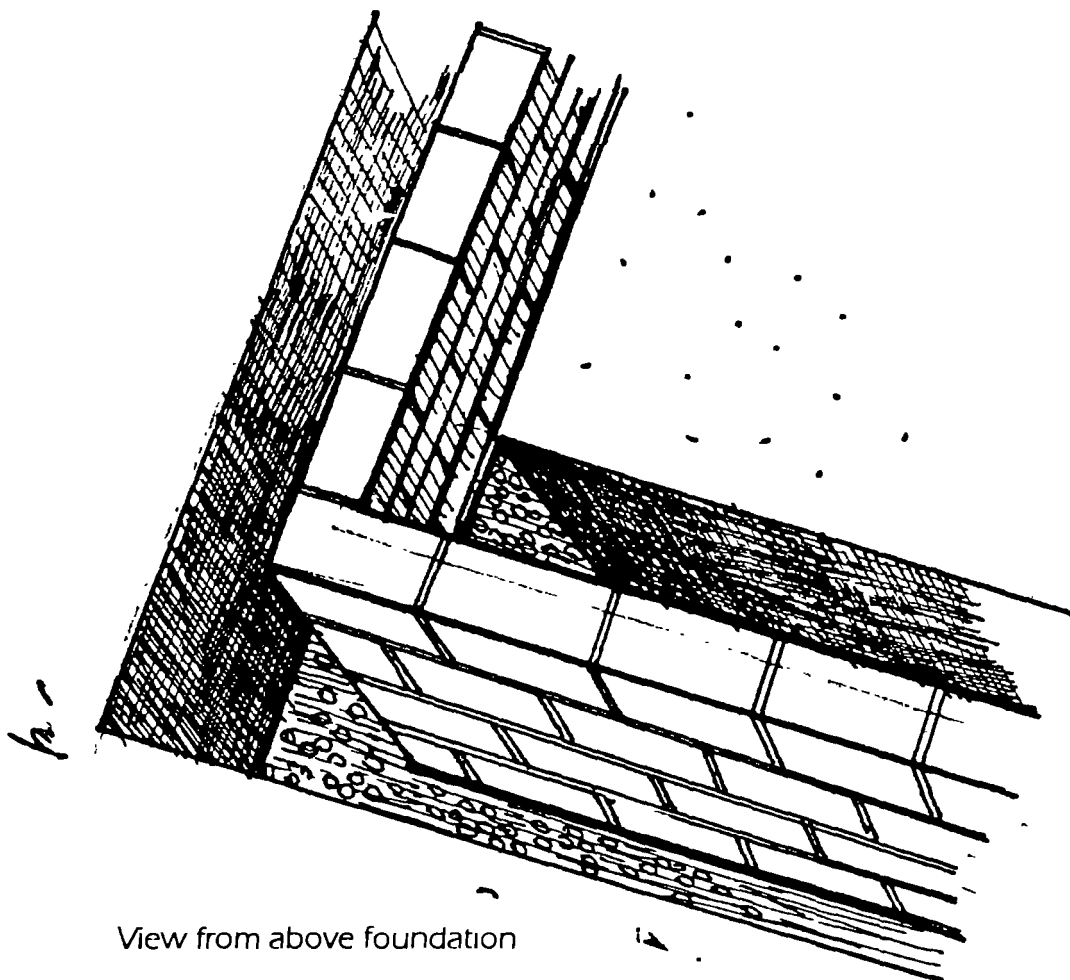
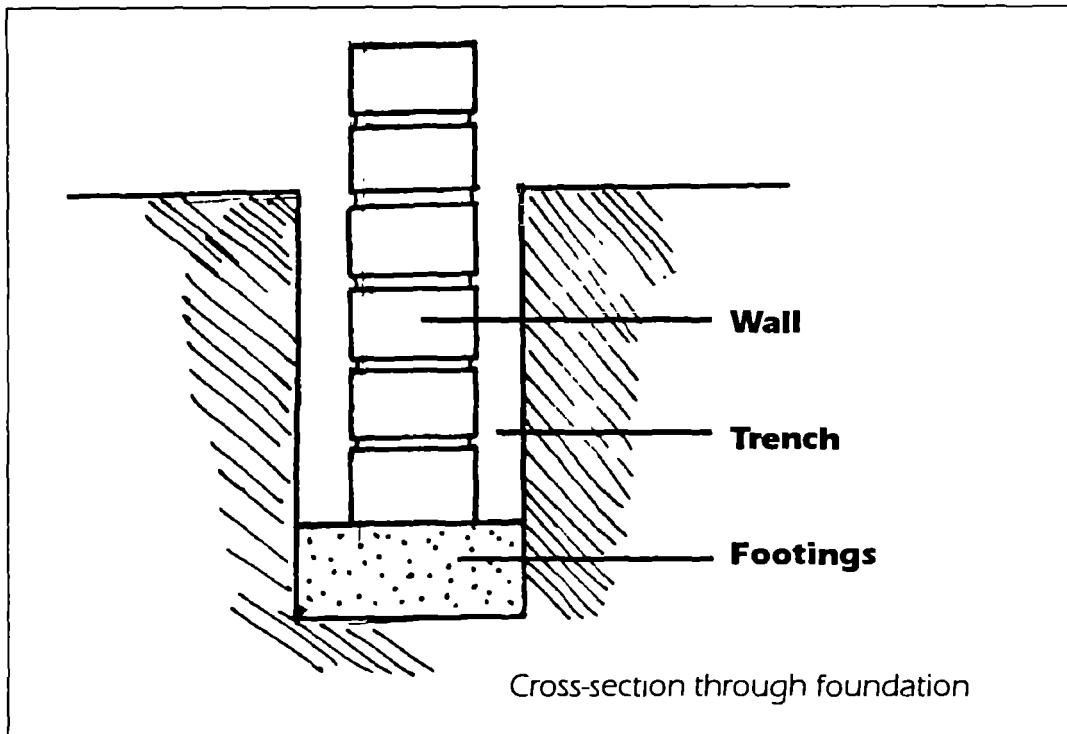

MAKING THE FOUNDATIONS

(1) Digging the Foundation Trenches

When all the lines for the foundation are in, a trail of sand is laid on the ground to mark where the labourers must dig.

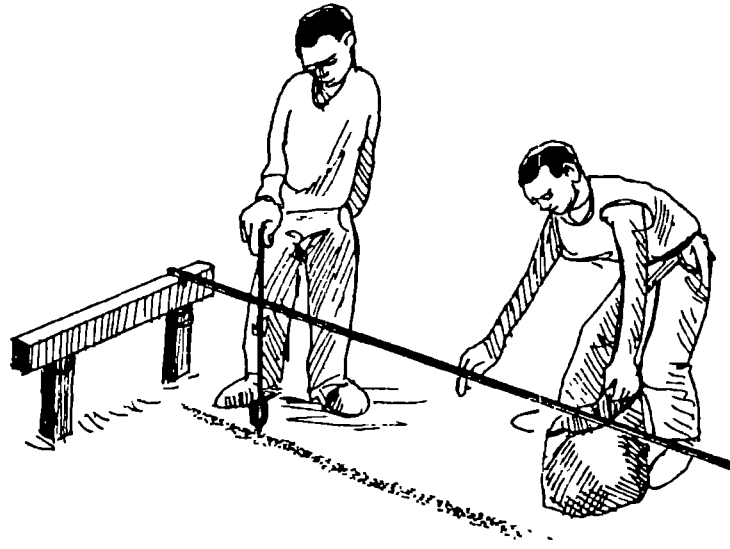

The building lines should be removed while digging is going on, to stop them being broken or getting in the way

Any time you need to check that the digging is accurate, simply put back the lines between the notches of the profile boards.

Foundation trenches should always be dug deep enough to reach firm soil. The minimum depth of the foundation trench should be 600mm below the original ground level

The sides of the trenches must be vertical and the bottom level. The corners must be square

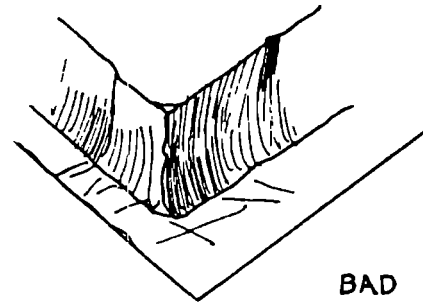
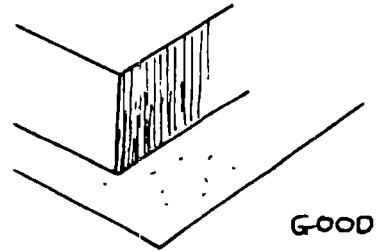

Check that the soil at the bottom of the trench is firm. If not, the Supervisor must ensure that action is taken to reinforce the building. Some suggestions are given below.

Modifications For Weak Soil

- Deepen the trenches until firm soil is reached. If firm soil cannot be reached, consider the following options:
- Reinforce the footings with concrete.
- Fill almost the entire depth of the trench with concrete.
- Lay a complete reinforced concrete slab about 200mm thick and construct the entire building off this.
- Put in a ring beam at wall plate level. A ring beam is a strip of reinforced concrete that goes right round the building.

These modifications are expensive and may not stop the building from subsiding. It is much better to look for a better site.

If you are in any doubt, SEEK SPECIALIST HELP.

(2) Marking the Depth of Footings Concrete and Levelling

Pegs are driven into the bottom of the trench, so that the length of peg sticking out of the ground is equal to the depth of the footings. This should be about 200mm.

The tops of the pegs must be level.
If they are not then the trench is not level.

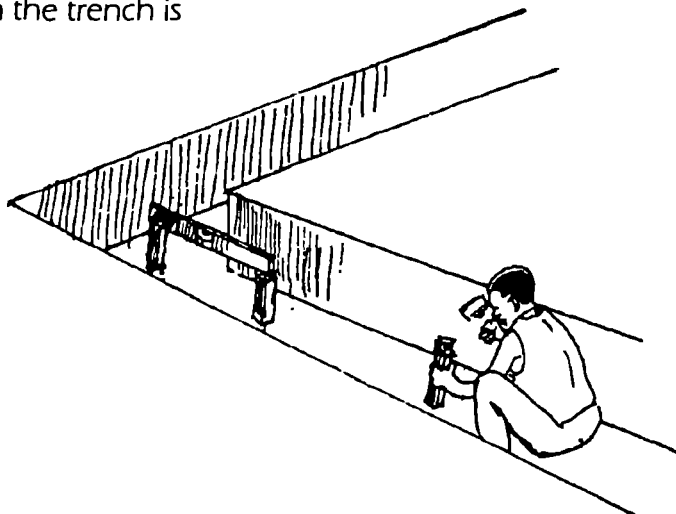

The trench must be made level by REMOVING soil, never by adding soil. If soil is added, the foundation may fail. It may mean digging the trench slightly deeper, but it will ensure your building remains strong.

(3) The Footings

The footings spread the weight of the walls over a wide area.

see
page 30

The footings should be a 1:2:4 mix. You can use MASS CONCRETE, which has the largest stones in it - up to 6cm across (see page 42)

The concrete is compacted and levelled to the height of the pegs in the trench, using a straight edge or strike board

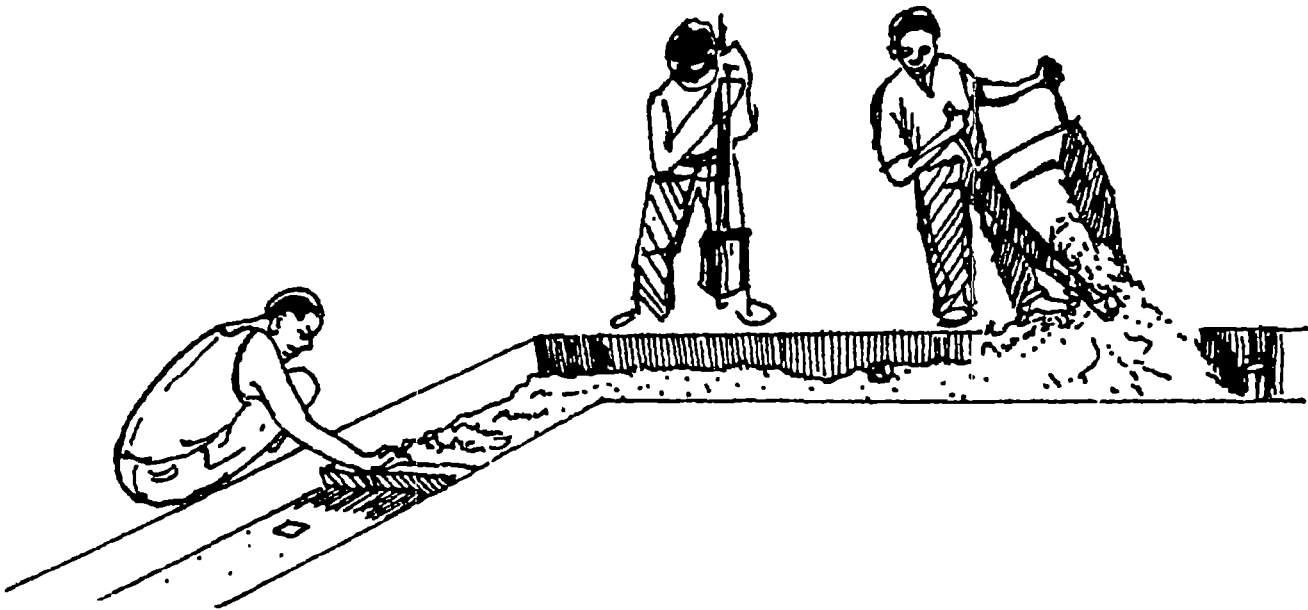

The pegs should be removed and the holes filled with concrete.

see
page 43

Leave the concrete to cure until it is strong enough to work on (see page 43)

(4) Foundation Wall

The foundation wall is built in the centre of the footings.

Properly burnt bricks or SOLID concrete blocks can be used to make the foundation wall. DO NOT use hollow blocks.

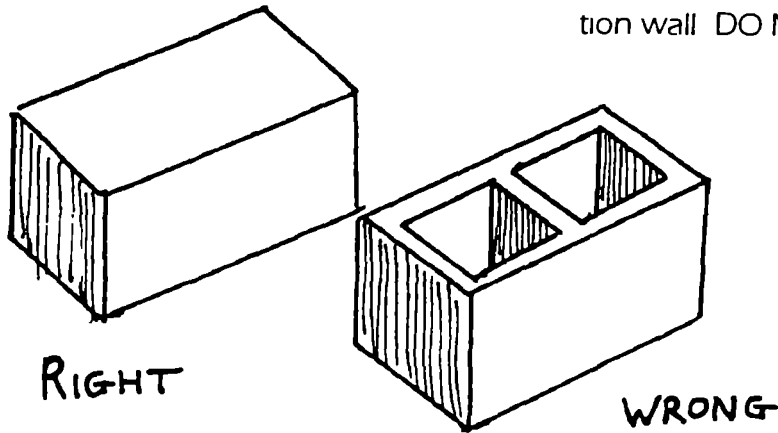

If building with burnt bricks, use the strongest bricks in the foundation wall, because they must support the entire building

see page 100

Different types of wall should be different thicknesses. See page 100 for details.

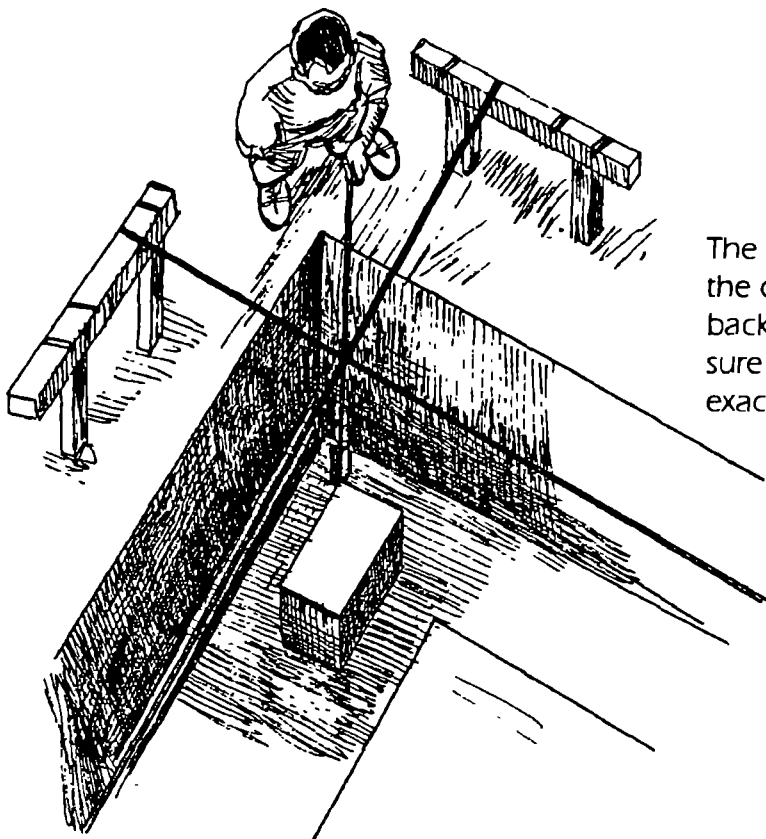

The foundation wall must be started at the corners (see page 103). Put the lines back over the profile boards and make sure the corner bricks or blocks are in exactly the right place.

see page 103

The first 2 courses MUST be absolutely level and plumb (see walls for details).

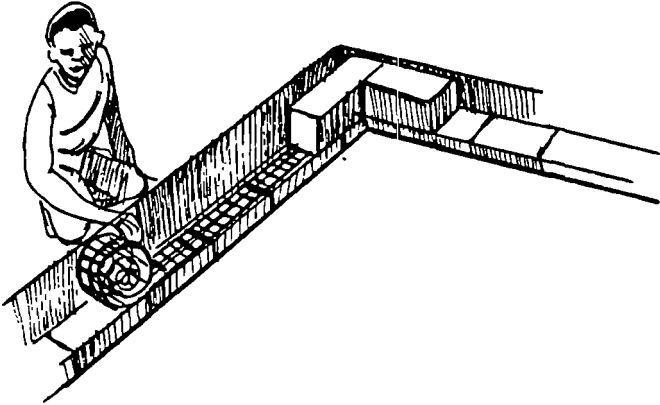

If the foundation walls have 4 or more courses, layers of BRICKFORCE should be put into the walls every third course. However, if the foundation wall is only 4 courses high, the brickforce goes in the second layer.

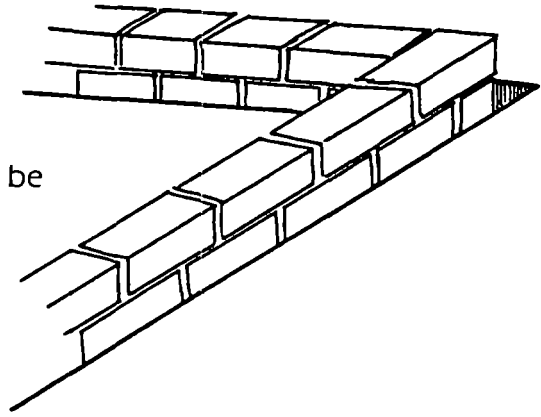

The top of the foundation wall should be about 150mm above ground level.

(5) Plastering and Backfilling

The outside of the foundation walls should be plastered and painted with black bituminous paint. See PLASTERING for more details.

The foundation trenches are then refilled and compacted. This is called BACKFILLING.

The backfill for trenches INSIDE the foundation wall must not include soil or clay. Use a good hardcore or laterite.

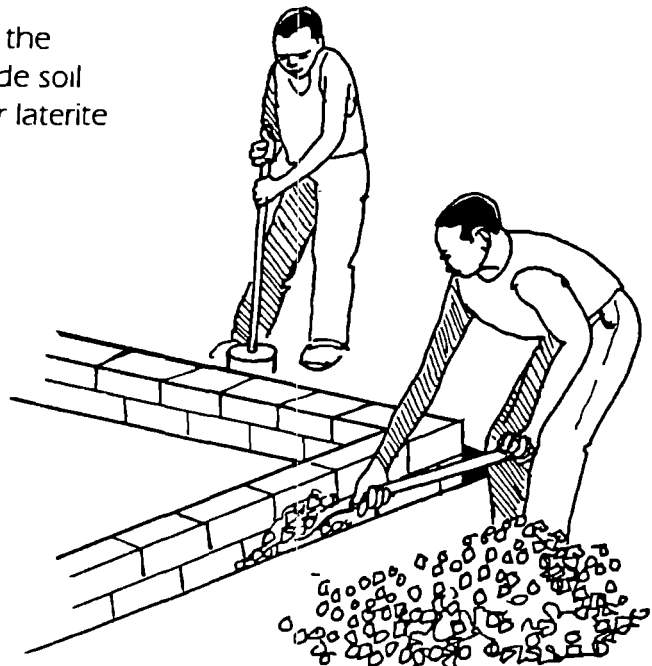

(6) Ant Treatment

It is essential that you add poison to the trenches when you backfill.

Read the instructions on the container carefully

Follow the instructions closely.

All poisons are dangerous.

Do not walk on soil treated with poison.

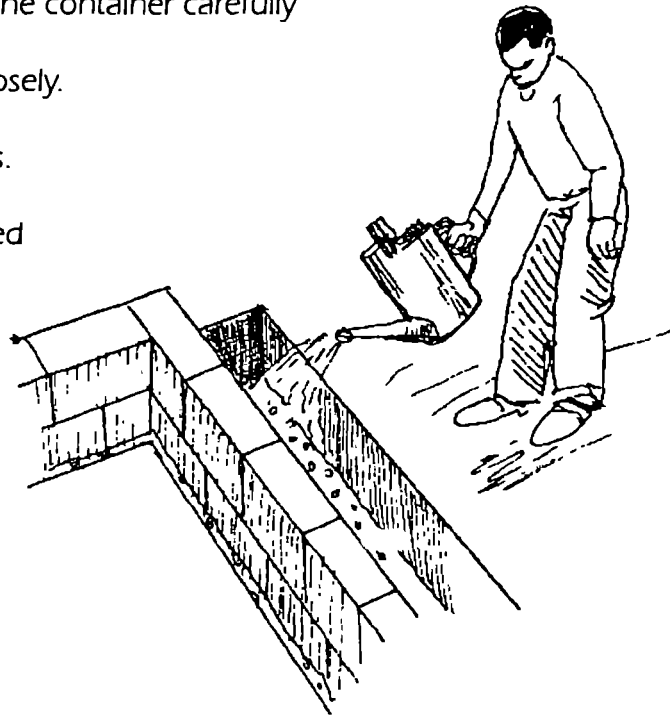

(7) Veranda Poles and Piers

If you are using metal veranda poles, the labourers should leave a gap in the foundation wall down to the footings

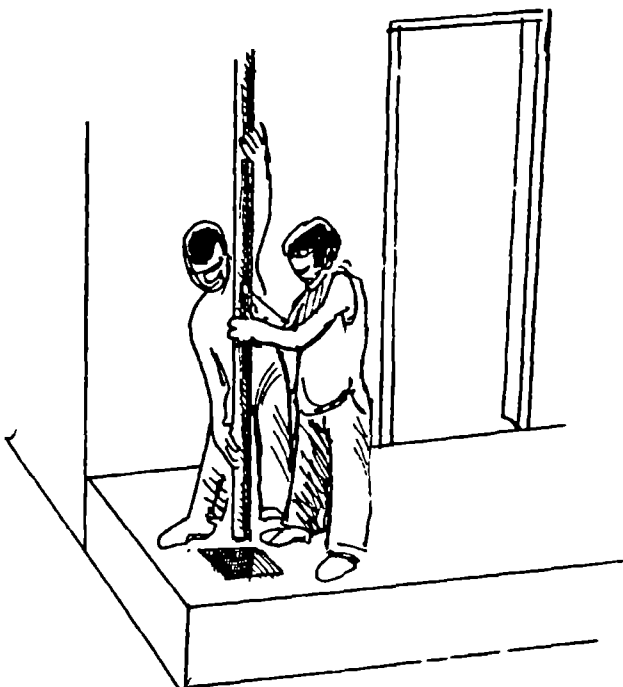

Once the foundations are complete and the veranda is laid, the pole is set into the hole and filled around with concrete.

It is also acceptable to make brick veranda piers instead of metal poles, but make sure an ant guard is put in the pier to stop ants getting to the roof timber (see Page 101)

see
page 101

KEY POINTS

- the foundation **MUST BE STRONG**, or your building may collapse
- if there is any doubt about how firm your soil is **SEEK SPECIALIST HELP**
- reinforce foundations in weak soil. It is more expensive, but necessary
- **NEVER** use hollow blocks in foundations

Floors

Parts of a floor
Making a good floor
Laying the slab
The floor screed

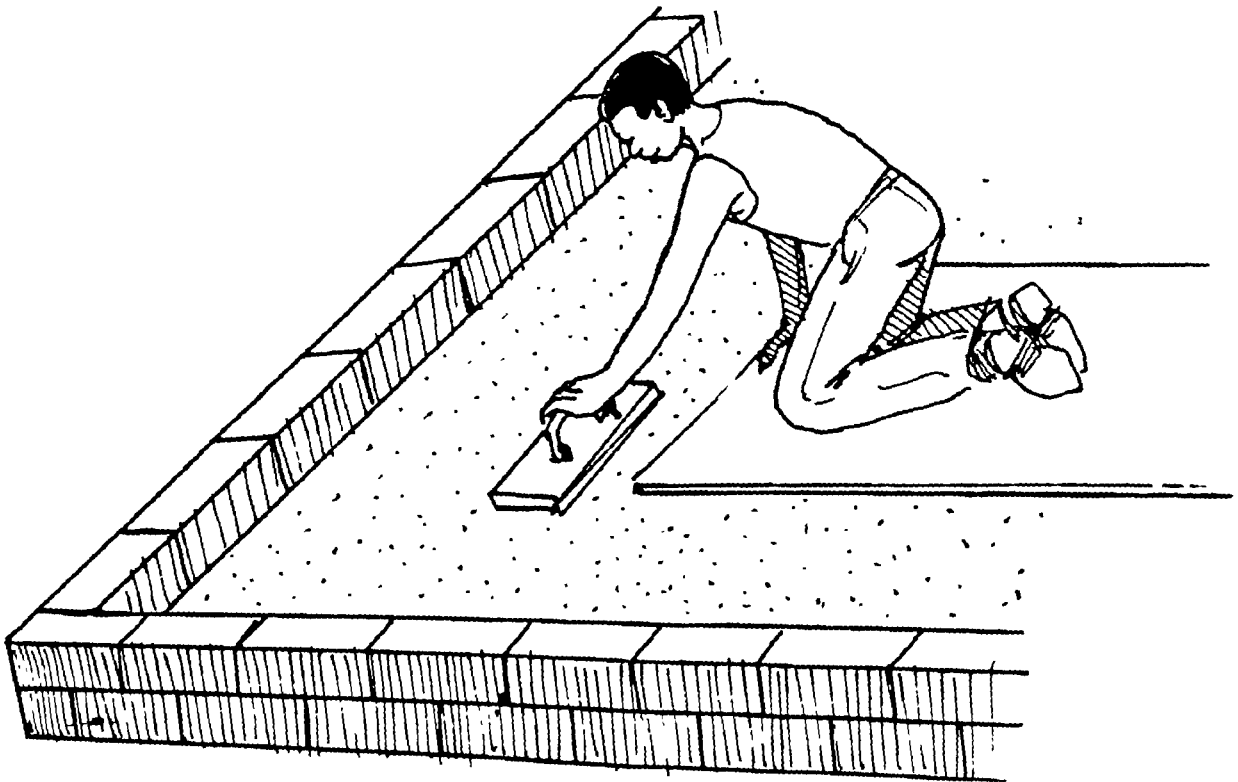

INTRODUCTION

The main parts of a floor are

- the hardcore or laterite fill,
- a layer of plastic, called the damp proof membrane (DPM),
- the base, which is normally a reinforced concrete slab,
- the top layer, which is called the floor screed.

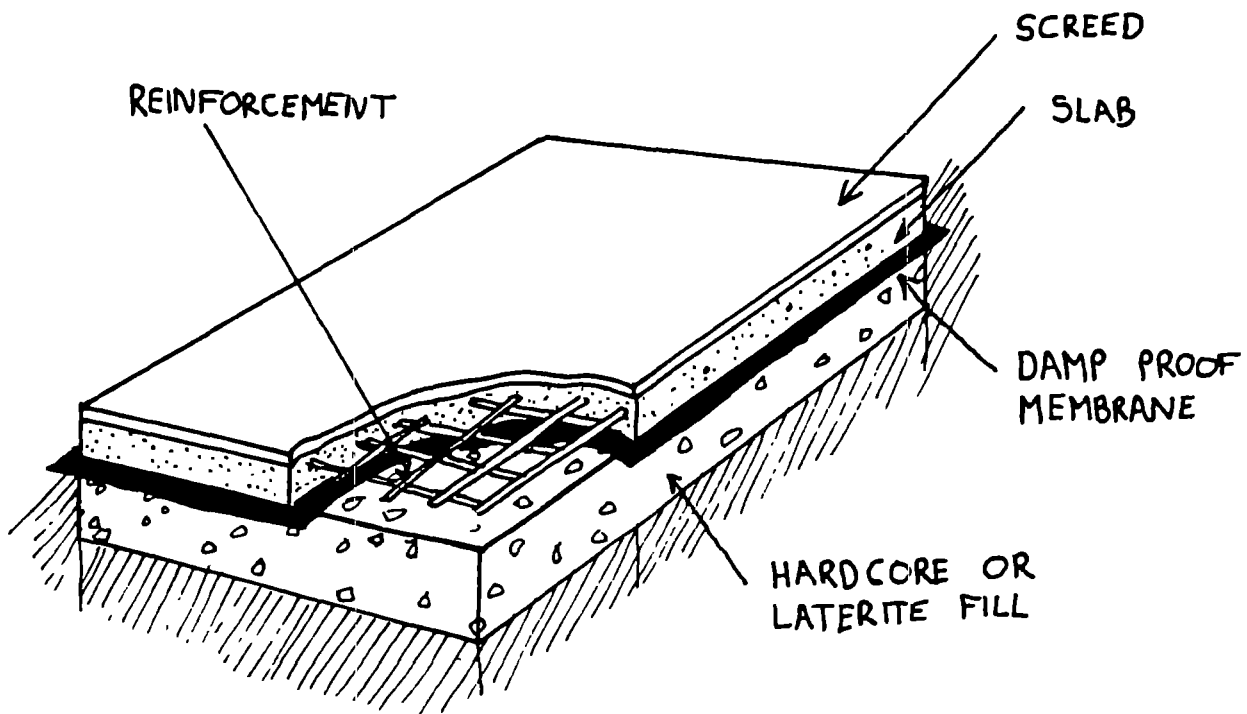

Getting the floor right is difficult. If it is not done with care your floor will soon have serious cracks in it, especially large public rooms such as classrooms and clinics.

This book describes a method that should give a strong, long lasting floor.

THE FILL

The fill can be hardcore or laterite.

If it is not well made, it will compress under the weight of the floor slab and your floor will soon have cracks in it

The total depth of the fill must be at least 150mm.

The fill is done in layers, each layer a maximum of 100mm thick

Compact each layer
This is easier to do if each layer is watered

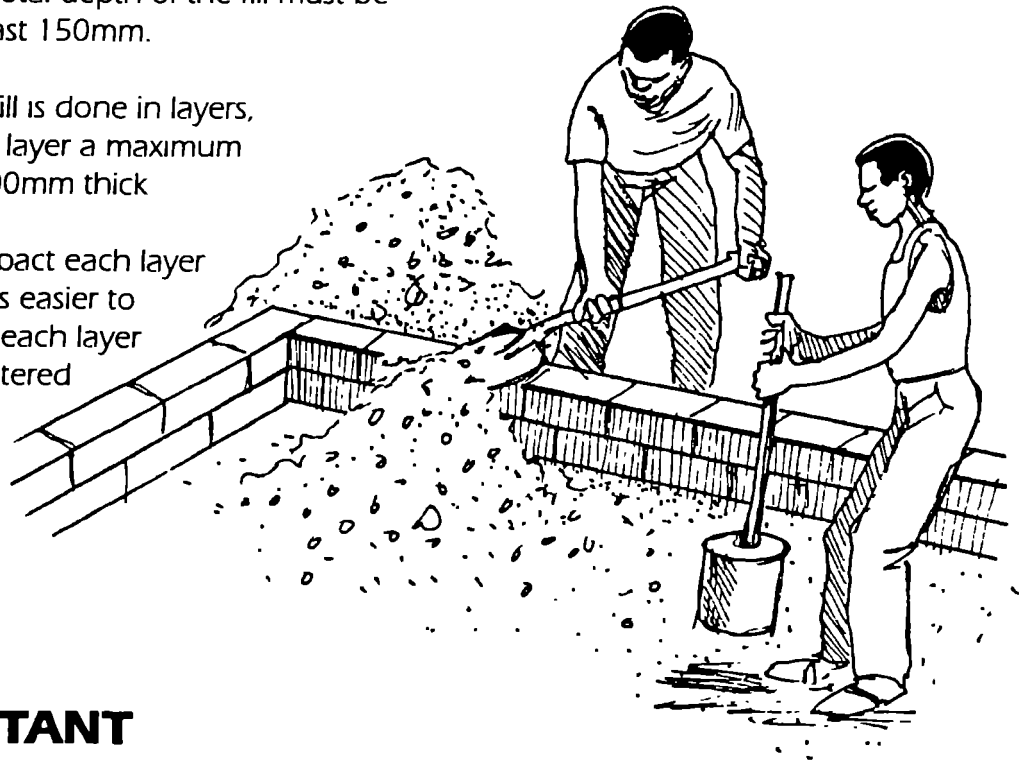

IMPORTANT

Ensure the top layer is accurately levelled, or it will be difficult to make the rest of the floor

ANT POISON

You must put ant poison in the fill to protect your building.

Do not walk on material treated with poison.

IMPORTANT

Read and follow the instructions on the packet carefully. All poisons are dangerous and must be treated with care

DAMP-PROOF MEMBRANE

MPU plans include a damp-proof membrane (DPM) which protects your buildings from moisture rising up through the ground

The DPM is made from sheets of THICK plastic or polythene sheet

Make sure the plastic you buy is thick and strong

HINT - If thick plastic is not available, you can use 2 layers of thinner sheet NEVER use a single sheet of thin plastic. If you do, it will tear

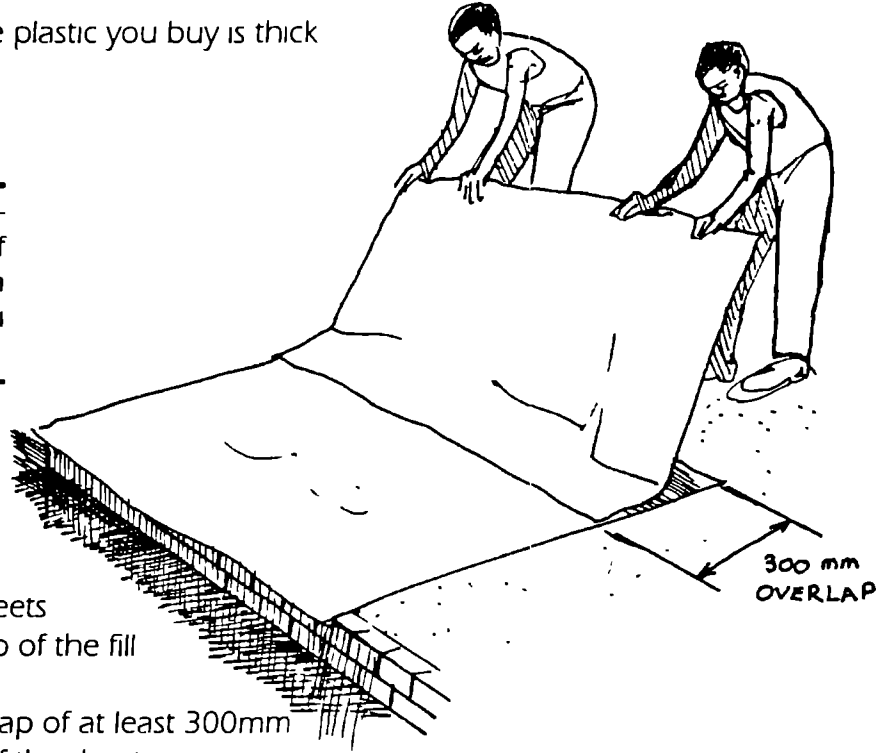

The plastic sheets are laid on top of the fill

Have an overlap of at least 300mm where each of the sheets join, to stop water getting past

HINT - Brush a thin layer of sand over the fill. This reduces the chances of sharp stones tearing the plastic

THE SLAB

Reinforced concrete floor slabs make the strongest floors. It is advisable to use this type of floor if at all possible

There are 2 very important rules when laying concrete floor slabs

- ALWAYS LAY AN ENTIRE FLOOR SECTION AT ONE TIME -

and

- REINFORCE CONCRETE SLABS WITH CONFORCE-

The common method of laying slabs in Zambia is to lay a single floor slab which covers the foundation walls.

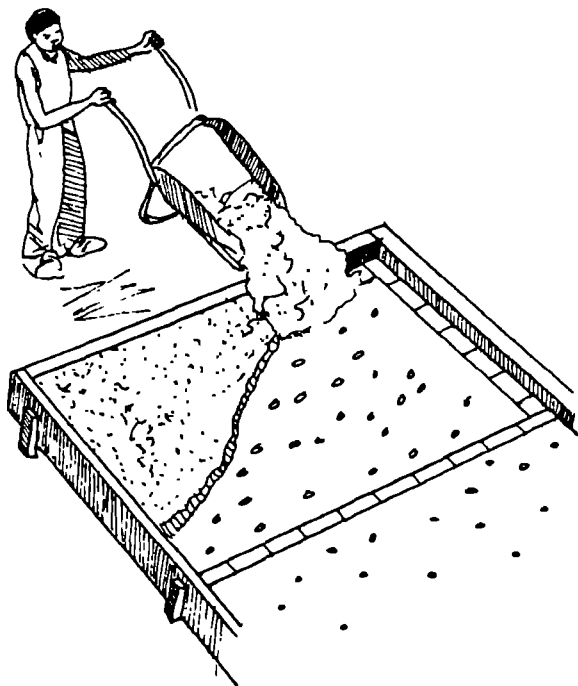

The advantages of this method is that the builders are familiar with it and it is possible that the slab can act as an ant barrier

However it also has several disadvantages

-Even if done carefully, large floor slabs are very likely to develop large cracks as the concrete cures.

-Laying large floor slabs requires a lot of labour, many of whom will be unskilled and inexperienced.

-The foundation walls and the fill carry very different loads. They will settle by different amounts. If the slab is built over the foundation walls this can cause the slab to crack near the walls.

This book recommends a better method, where the walls of the building are built up BEFORE laying the slab. The slab is then laid one room at a time.

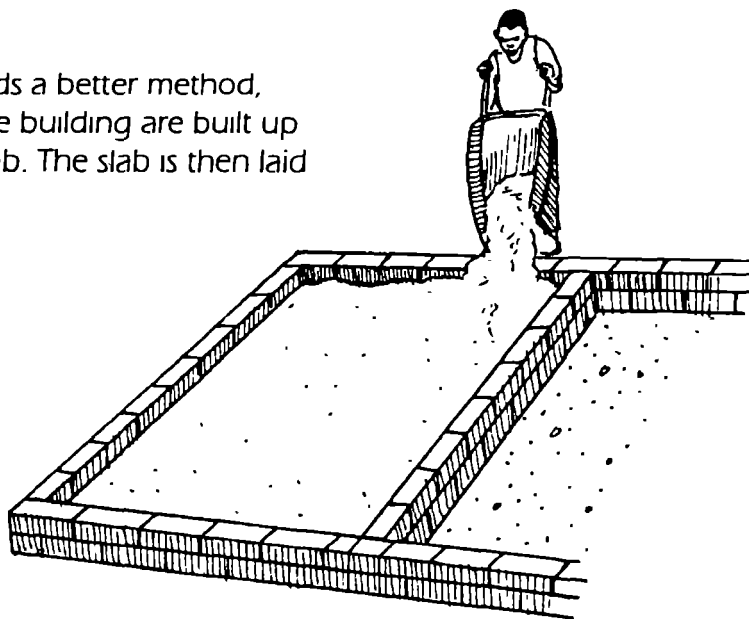

This method is better because

-Each section can be easily completed in a manageable time.

-The number and size of cracks that will develop are reduced.

-The walls and fill can settle independently, without causing cracks in the slab.

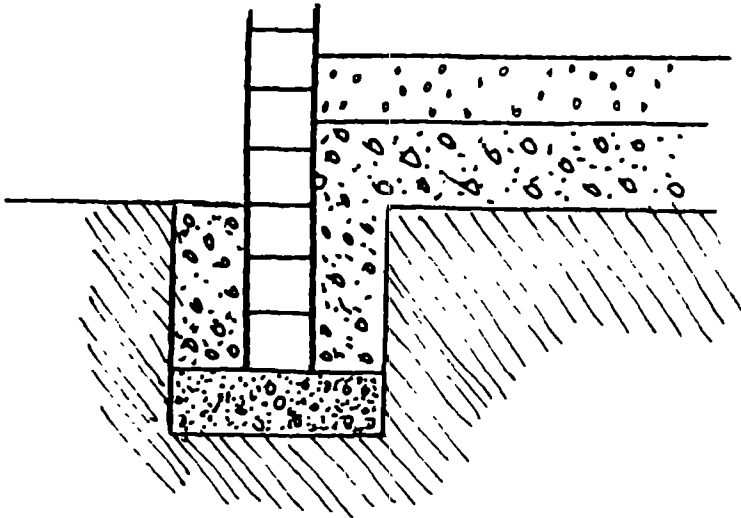

-The walls mean no shuttering is required around the outside of the slab.

It is also recommended that the slab is left until after the roof is completed. This means:

-The fill will be more compacted from all the walking that has been done on it since it was laid.

-The roof will protect the slab from the sun so it will cure better.

-There is no risk of the slab being damaged during the rest of the building work.

Discuss these advantages and disadvantages with your Supervisor, Foreman and Buildings Officer and choose the method most suitable for your area

IMPORTANT

If you use a method that your labourers are not familiar with they will need a lot more guidance from the Supervisor.

LAYING THE SLAB

Try to ensure the following stages are followed closely

(1) Prepare the Area to be Concreted

- clean the area and the edges of the foundation walls.
- make sure the damp proof membrane (DPM) is laid.

(2) If Necessary, Divide Up the Floor Area

It is recommended that the largest slab area that should be laid in one go is:

- 10m² for inside floors
- 5m² for outside floors.

Large rooms can be divided into smaller sections, called BAYS, using edge boards

THIS BOARD IS USED TO
LEVEL THE CONCRETE UP
TO THE WALL

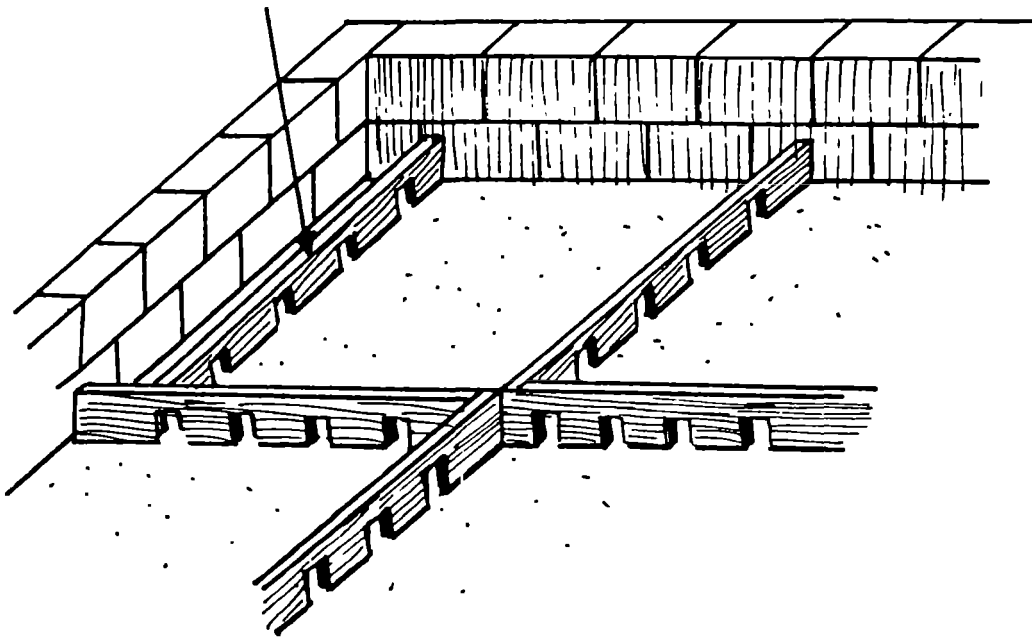

The edge boards must be supported with bricks or blocks, since pegs would tear the damp proof membrane

If the slab is to be laid in sections, the corners of each bay must be done as shown in the illustration. This will ensure the different sections of floor match up correctly

The edge boards should be accurately levelled to the required depth of concrete. This should be about 100mm.

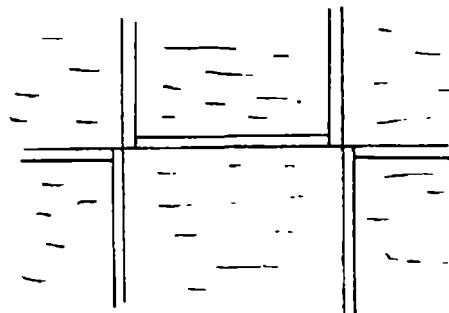

(3) Conforce

-the slab must be reinforced with conforce.

-prepare supports for the conforce to raise it up about 50mm off the ground.

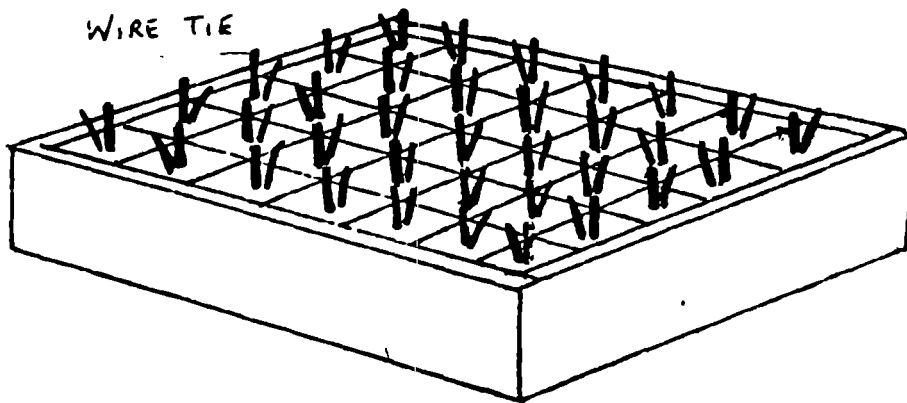
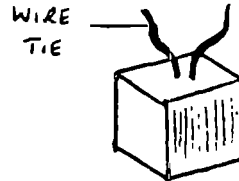

-the conforce is tied to the supports with wire ties.

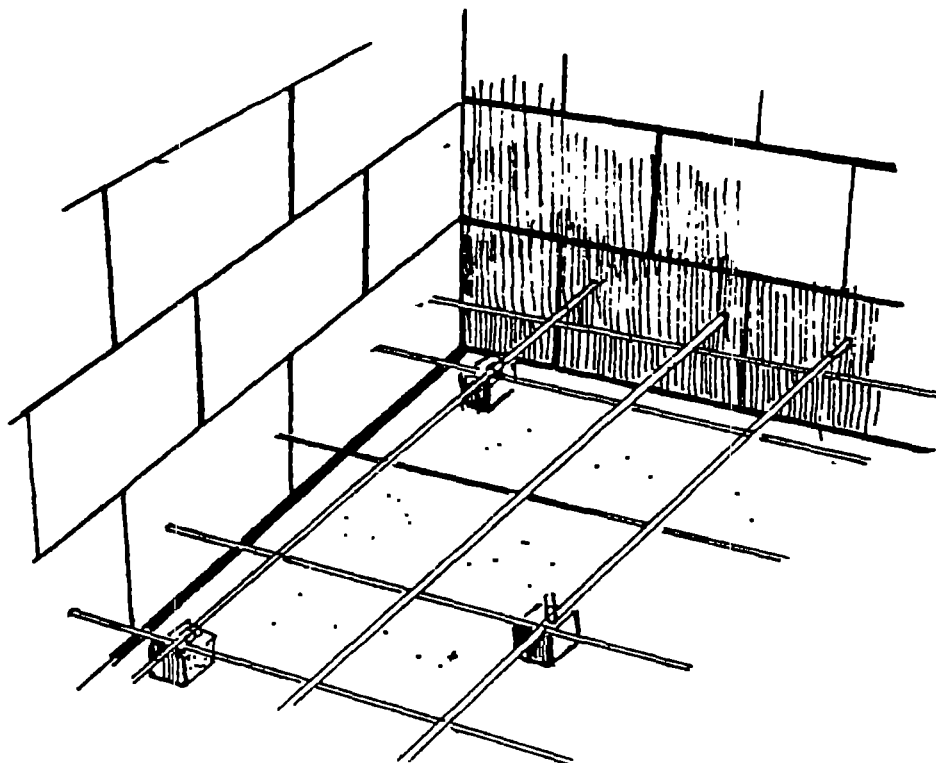

(4) Pouring the Slab

- MPU plans state the slab should be 100 mm thick, 1:2:4 concrete mix.
- pour the concrete. Make sure it completely surrounds the conforce.
- compact the concrete well with a tamper.
- level the concrete using the edge boards as guides.
- remove the edge board close to the wall and fill the hole with concrete.

IMPORTANT

Never stop a concreting process until an entire section is completed. If you do, the join will probably be faulty and will always be visible.

(5) Curing

- cover the slab with sand and leave it to cure.
- keep the slab damp while curing takes place.

SHRINKAGE AND EXPANSION GAPS

If the slab is laid in sections, inside floors will require shrinkage gaps and outside floors will require expansion gaps.

INSIDE FLOORS:

As the concrete cures it will contract. A shrinkage gap is used to allow this contraction to take place without cracking the concrete

When one set of bays has hardened, the edge boards are carefully removed.

The shrinkage gap is made by placing a piece of paper or plastic between adjoining bays

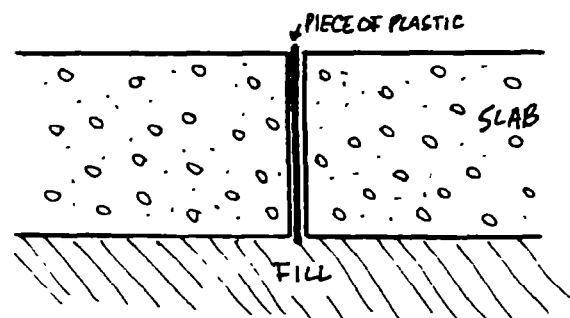

OUTSIDE FLOORS:

Outside floors expand in the heat of the sun. Expansion gaps are required to allow this expansion without the floor cracking.

On outside floors the edge boards should be left in position until all the bays have been poured.

The boards are then removed and wet sand is poured into the space left. This allows each bay to expand on its own without cracking

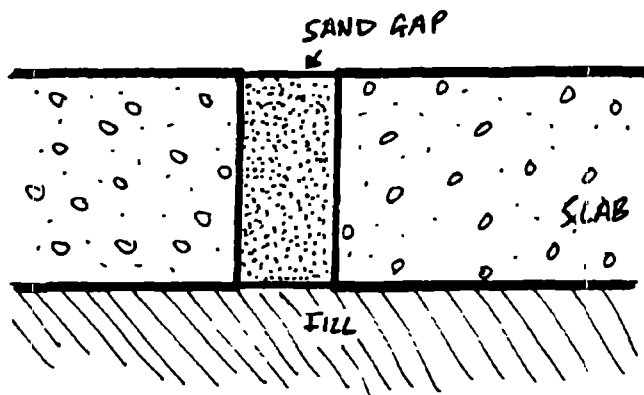

ALTERNATIVE TO CONCRETE SLABS - BRICK OR BLOCK PAVING

If getting stones for concrete is a problem in your area, you can consider making a block or brick base instead

(1) Bricks or blocks are laid across the hardcore. They should be pressed down well and made level.

(2) Fine sand is used to fill around the bricks or blocks. The sand should be well compacted. This is easier if the sand is slightly damp.

This method is cheap and simple, but will not be as strong as a concrete slab.

If you want to use this method, make sure the Regional Officer has approved your decision IN WRITING before you start.

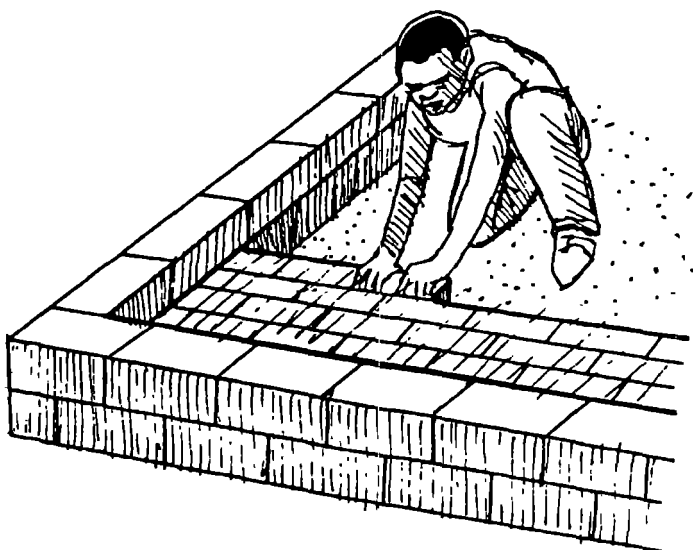

THE FLOOR SCREED

see
page 91

You should always lay the floor screed in sections, after the building has been roofed, for the same reasons as those given on page 91.

If the screed is laid at the same time as the slab, it can be done using the same bays

-The floor screed is a thin layer (1:4 cement:sand mix) laid on top of the slab.

-MPU plans specify that the floor screed layer should be 25 mm thick.

-Use river sand.

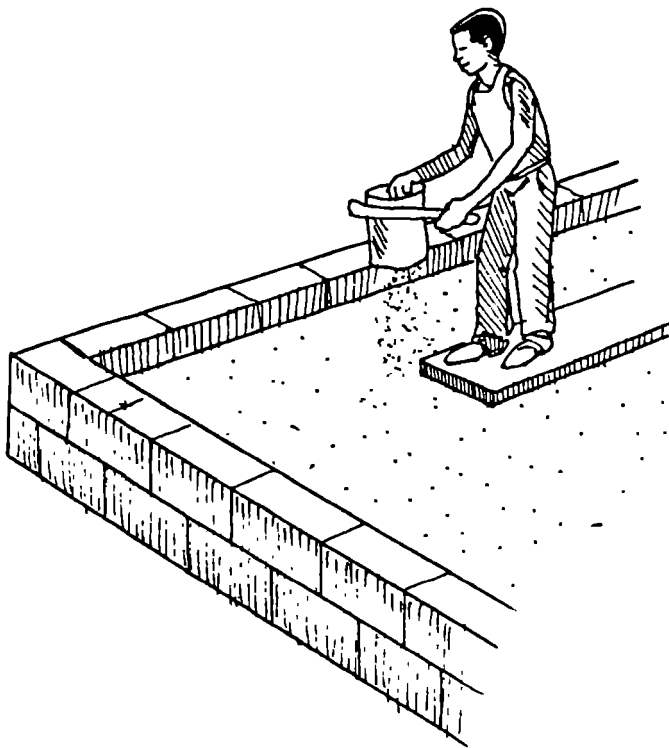

-The floor screed must be compacted and levelled.

-The screed surface is worked with a float until moisture comes through. It is then sprinkled with cement. Use a tin with holes in the bottom to get an even cover.

-The cement should be worked into the screed using the float. If done properly, this gives the floor a very hard, smooth finish.

-The surface is finished off with a steel float

-If the screed was laid in sections, making a bevel or angle along the edges of each bay with the point of the trowel gives each section a more attractive finish.

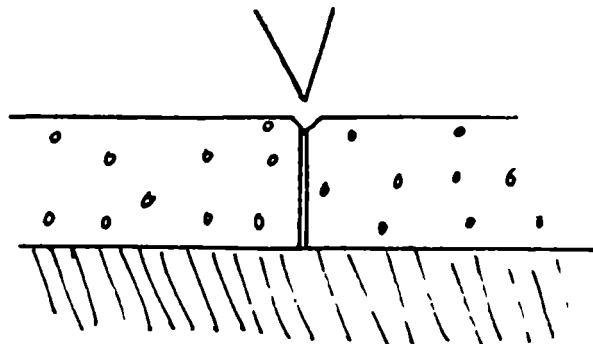

see
page 93

-Shrinkage gaps should be left between each section, just as with the slab (see page 93).

-The floor must be kept damp while curing takes place.

KEY POINTS

- the hardcore or laterite fill must be well compacted
- use THICK plastic sheet for the damp proof membrane
- divide large floor slabs into sections
- reinforced concrete slabs make the strongest floor
- take care to give the floor screed a smooth, hard finish

Walls

Bonding

Ant guards

Building the walls

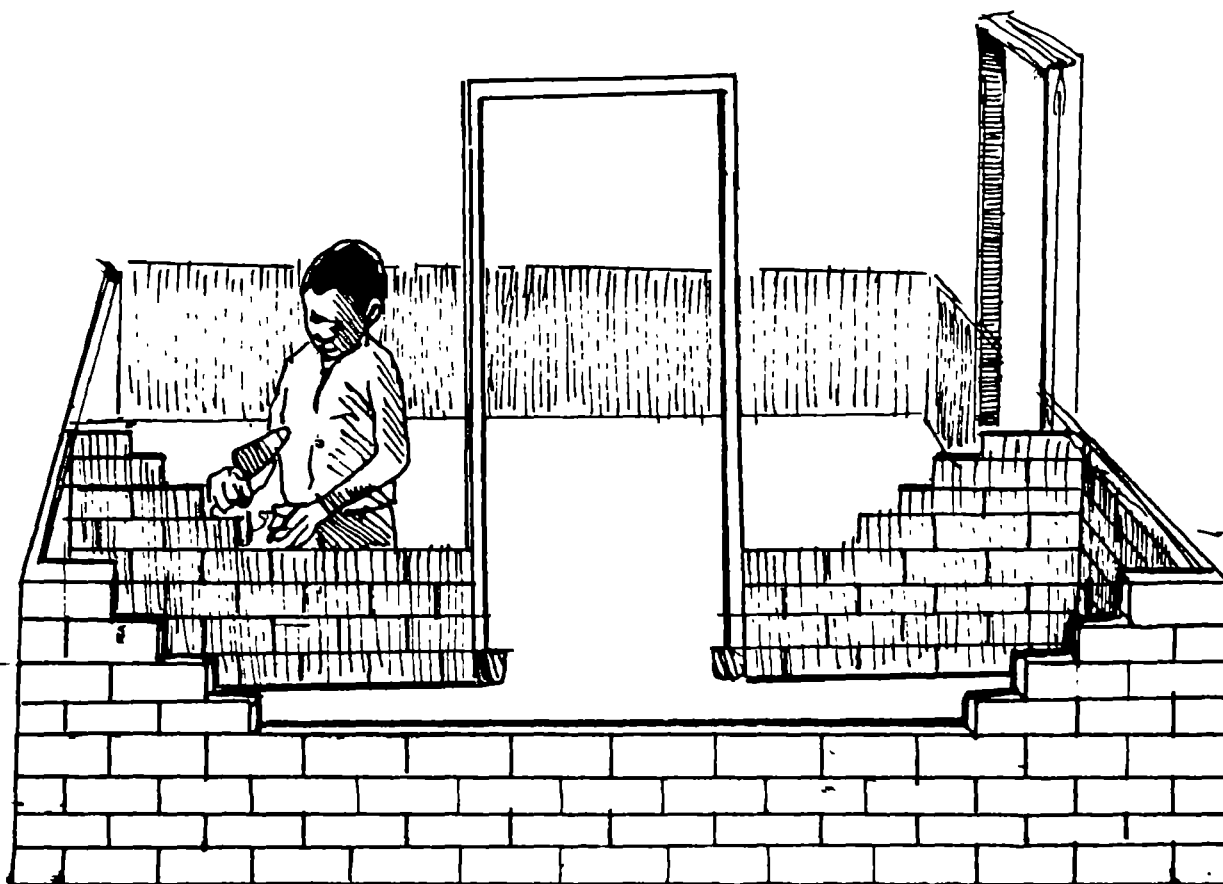

INTRODUCTION

Each layer of bricks or blocks in a wall is called a COURSE

These are held together by a mixture of sand and cement called MORTAR
Making mortar is described in Chapter 6

When mortar dries it should be almost as hard as the bricks or blocks themselves.

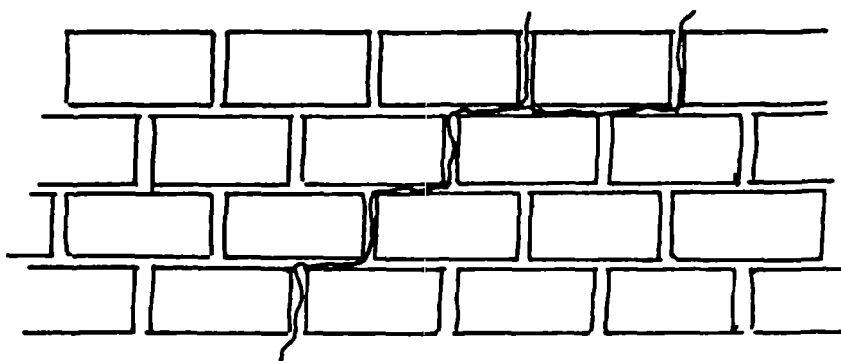

-strong bricks with weak mortar will result in cracks that go through the mortar and around the bricks.

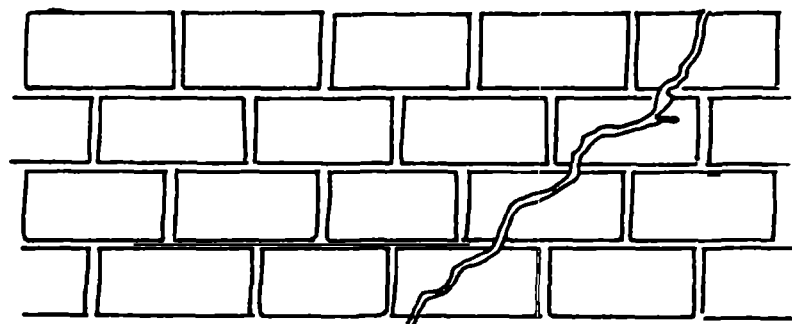

-strong mortar with weak bricks will result in cracks that go through the middle of bricks.

BONDING

The pattern of bricks in the finished wall is called the BOND. Some common bonds are shown in the illustrations

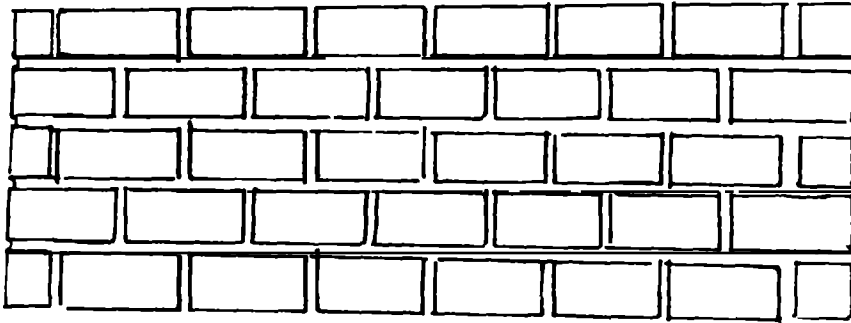

Notice that

-there are no vertical joints in the wall. This would make a weak bond.

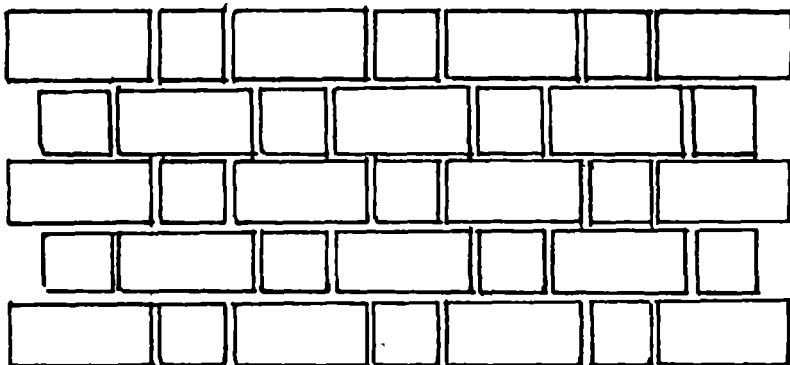
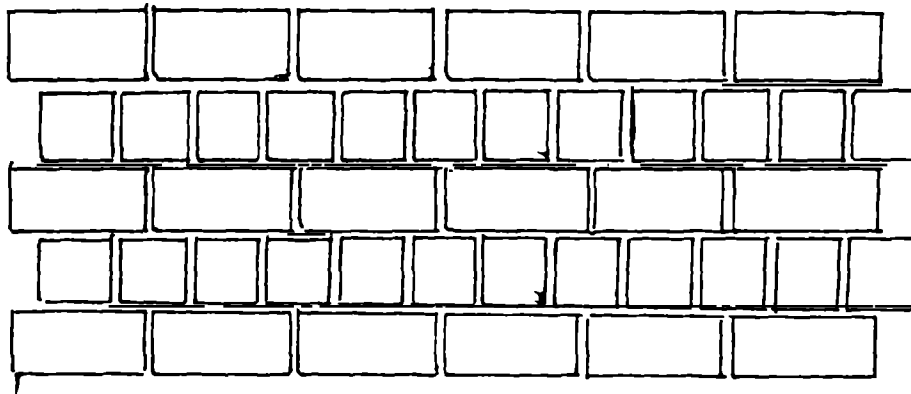

-walls which are 2 bricks thick should have some bricks which are laid across the wall. These give the wall a lot of extra strength. Bricks that go across the wall are called HEADERS.

If the pattern of the bricks that your bricklayers are laying does not look like the illustrations, check with your Supervisor that the methods the bricklayers are using are acceptable. They may be simply making a different bond, because there are many different types that can be used.

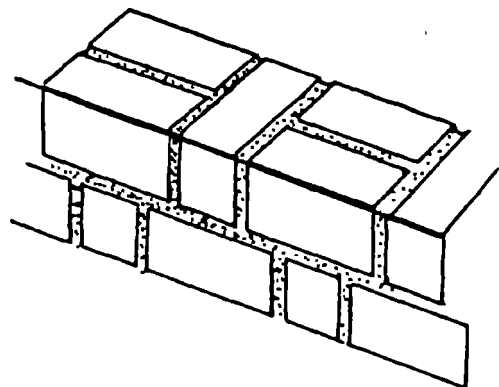

LOAD BEARING AND NON-LOAD BEARING WALLS

-Load bearing walls support the roof. They must be at least 150mm thick. They can be built by making the wall 2 bricks thick, or by using 6" or 8" concrete blocks.

-Non-load bearing walls separate rooms, but do not support the roof. They must be at least 100mm thick. They can be 1 brick thick or built with 4" concrete blocks.

LAYING THE BRICKS

Mortar will not stick easily to dry bricks. Therefore the labourers should:

-wet the previous course before laying the mortar for the next one, and

-wet each brick or block before it is laid.

Mortar dries out quickly when it is spread on the wall, so the bricks should be laid quickly

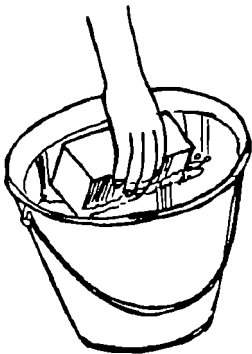

The mortar must fill the whole width of the wall. The bricklayers make sure this happens by making a hollow down the middle of the mortar using the end of the trowel. This is called the MORTAR BED. When a brick is placed on the mortar bed and pressed down, the mortar is forced to the centre of the wall. The brick is then tapped level

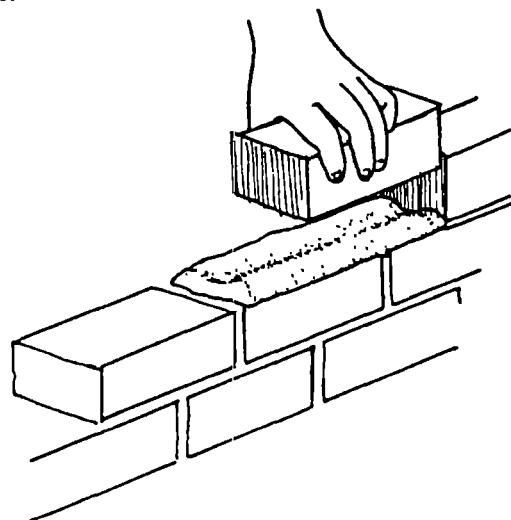
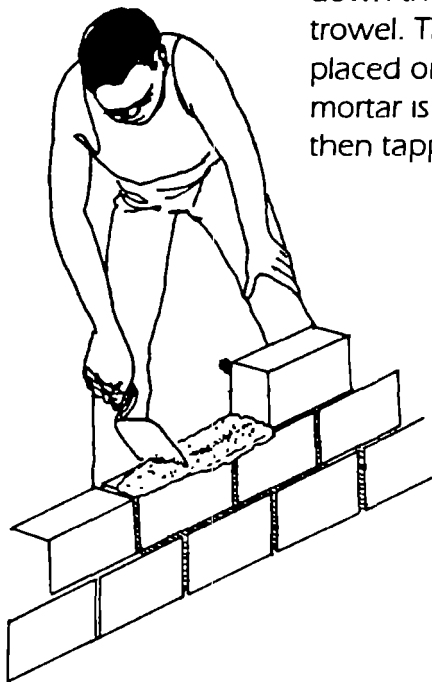

HINT -A good mortar joint should not be much thicker than the thickness of your little finger

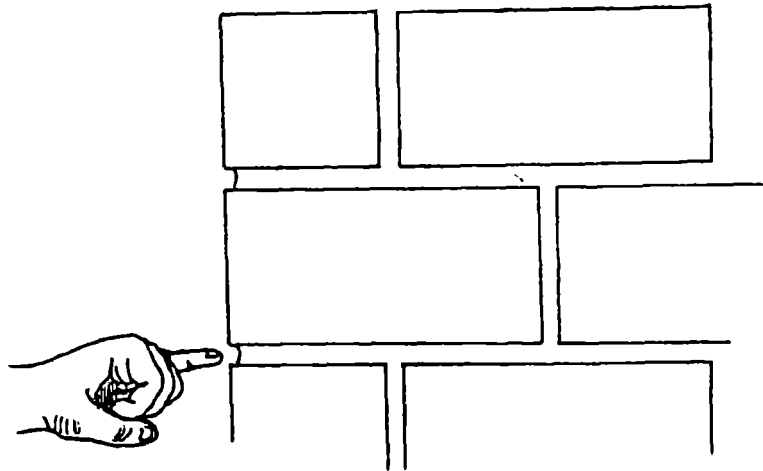

When building with hollow blocks, the solid face must face up, so that the bricklayer is not filling the hollows with mortar.

ANT GUARD

Your building should be protected from ants by an ant guard

The ant guard is put in at slab level. It should go right round the outside of the building.

The ant guard should be at an angle and have sharp corners, which ants find difficult to get over

The ant guard can be made in different ways:

-from metal strip. This is probably the best option, although ideally all joints need to be soldered to keep out ants.

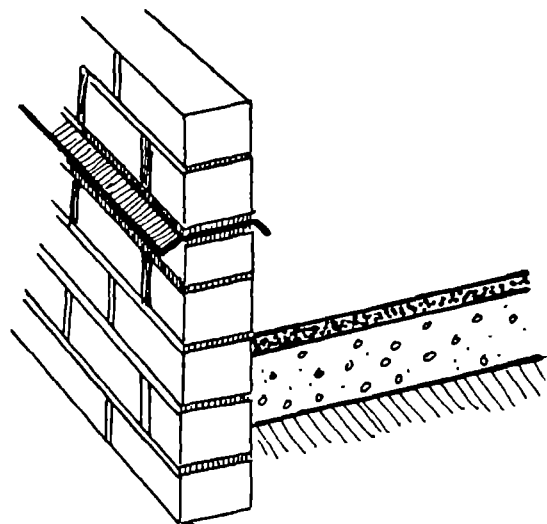
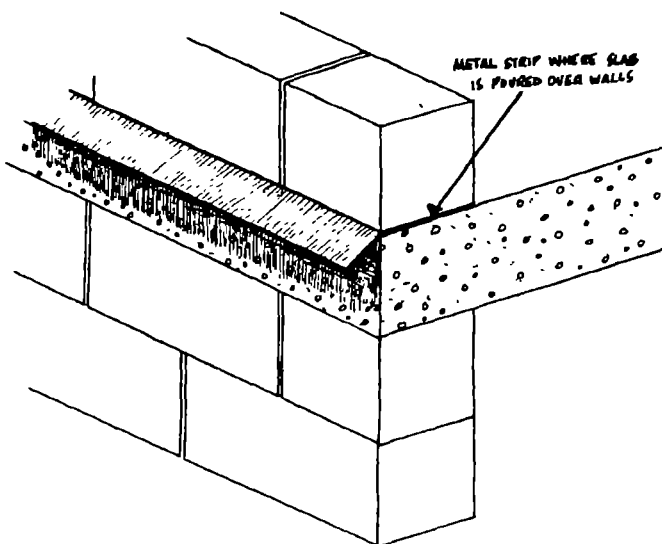

-you can cast a concrete ant guard,

-you can extend the slab past the walls.

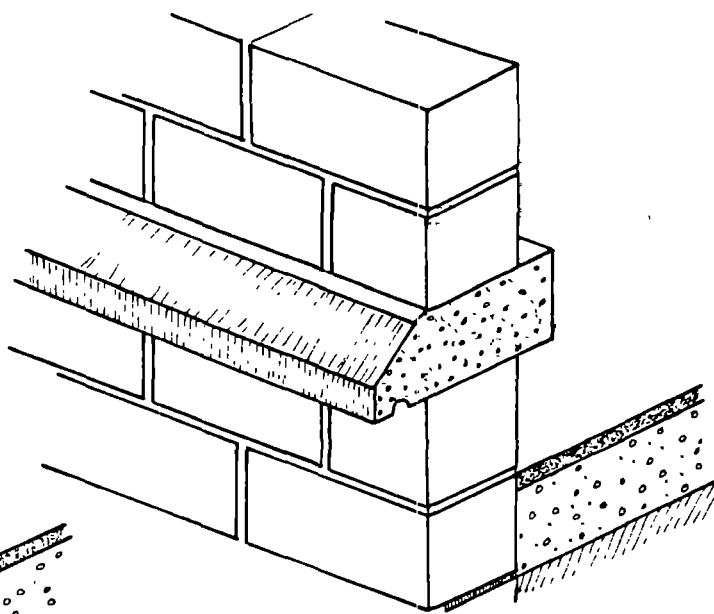
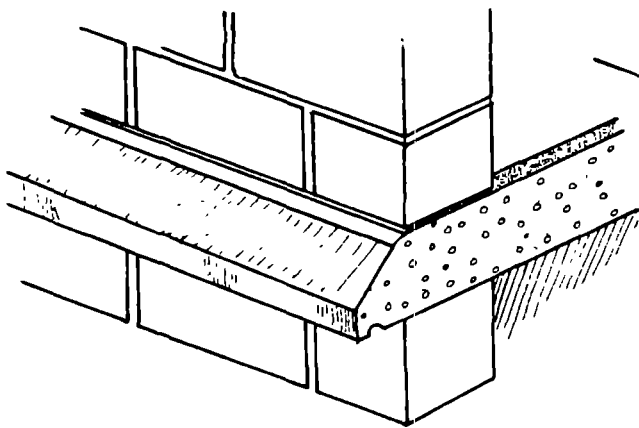

IMPORTANT

Whichever option you use, there must be no holes in the ant guard. Ants can get through a hole the size of this full stop_

DAMP PROOF COURSE

Your building needs to be protected from damp rising through the walls. This is done by fitting a DAMP PROOF COURSE (DPC) in the walls, just above slab level. The DPC is laid on bare bricks and the mortar bed is placed on top of the DPC.

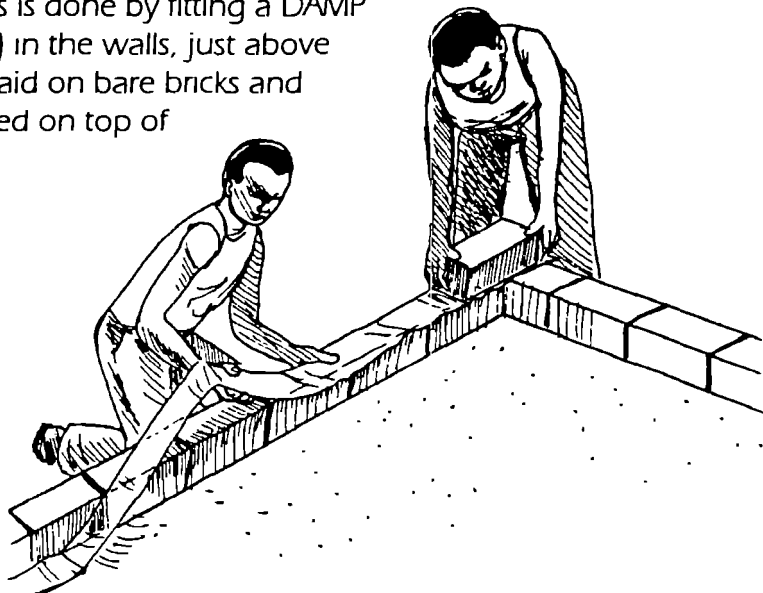

see
page 88

Like the Damp Proof Membrane used in the floor (see Page 88) the DPC must be strong so that it does not tear. For this reason MPU plans specify 3 ply DPC.

THE FIRST COURSES

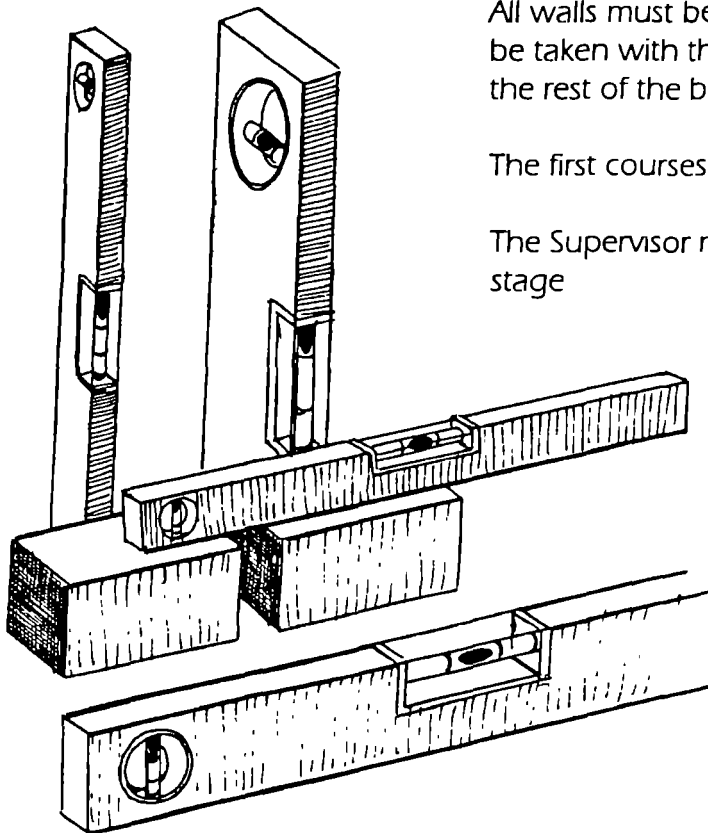

All walls must be built accurately, but special care must be taken with the first 2 courses. If they are not right, the rest of the building will also be wrong.

The first courses **MUST** be level and vertical (or plumb).

The Supervisor must check frequently during this crucial stage.

HINT - The lowest bricks in the building support the greatest weight. Always use the best bricks in the lowest sections of the wall.

CORNERS

The accuracy of the walls depends on the corners.

The corners must be built first. Each corner is built up several courses, then the walls in between are built. No more than 4 courses should be built at a time to allow the mortar to harden.

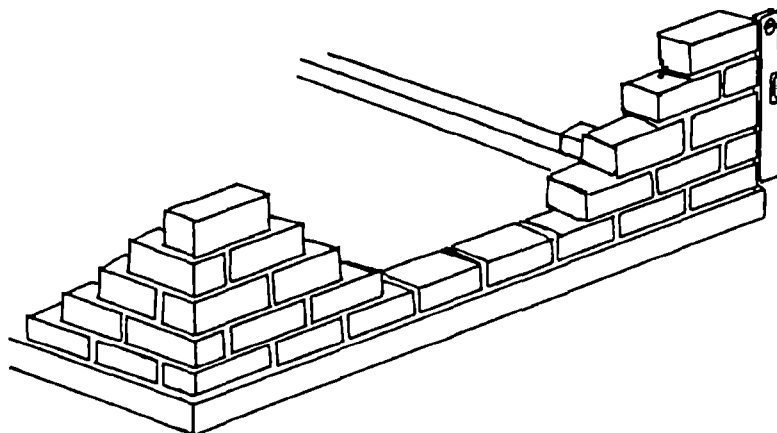

MAIN WALLS

Spirit levels or plumb bobs should be used to check that the corners are level and vertical.

When the mortar has hardened a little, a building line is fixed at each corner and pulled tight. The line is held about 4mm away from the wall by a stick or peg at each corner. The bricklayers use the line as a guide, keeping the gap constant by eye. They should not try to build close against the line.

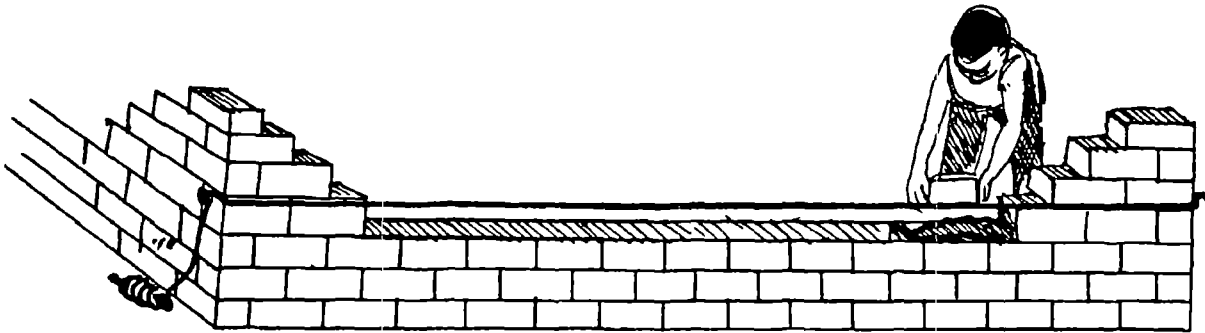

IMPORTANT

Make sure your builders construct all the walls at the same time - not the outside walls first, then the inside walls. Your building will be stronger this way.

BRICKFORCE

see
page 46

Brickforce will give your walls a lot of extra strength (see Page 46). Make sure a layer of brickforce is put in every 600mm up the walls.

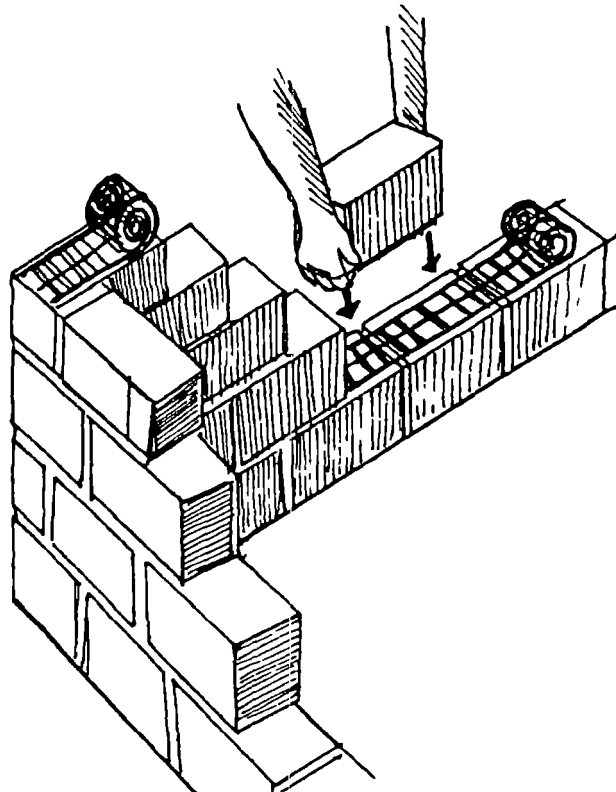

AIR BRICKS

- Air bricks come in pairs, an outside one and an inside one.
- Do not plan to place air bricks above windows or doors because there should be concrete lintols in these places.

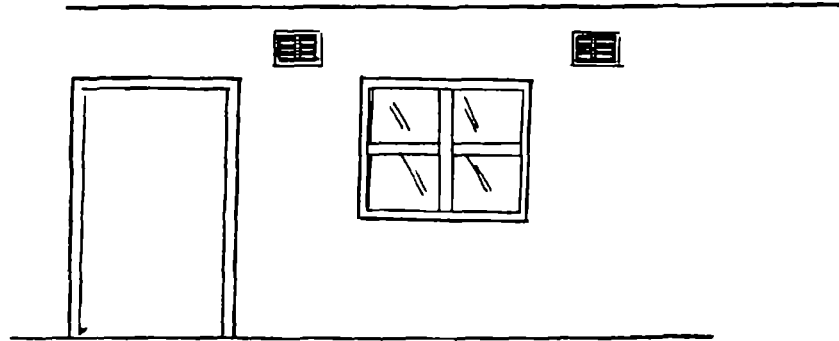

ROOF TIES

see
page 126a

When the walls have reached about 1 metre from the top, make sure lengths of strong wire about 4 metres long are built in. These wires will be used later to tie down the roof (see Page 126)

GABLES

Gables are the pointed walls of the building. Extra care should be taken to make sure the gables are accurate if they support any part of the roof. If they are not accurate, the roof will be difficult to construct.

One method of building the gables accurately is to:

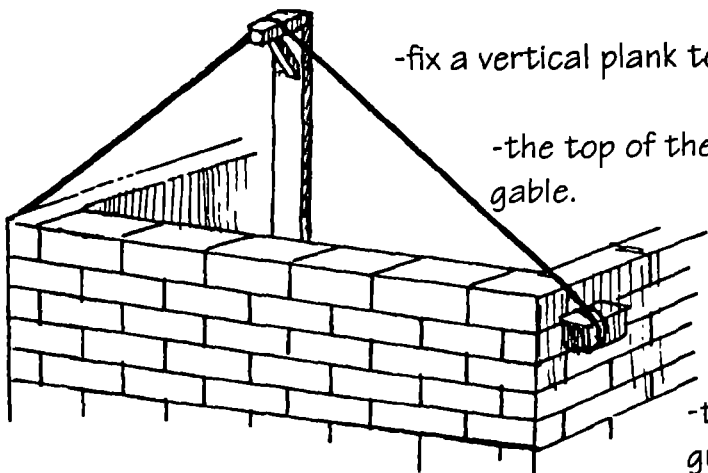

-fix a vertical plank to the middle of the gable walls.

-the top of the plank should be at the height of the gable.

-attach a line over the plank down to the side walls. Bricks are used to keep the line tight.

-the bricklayers use this line as a guide to make the gables.

Spaces should be left for the purlins, if necessary. These spaces must be in the correct place - look at the plan. It is better than breaking the wall afterwards.

Do not forget the wires to tie down the roof, 1 metre from the top

POINTING AND RAKING OUT

Pointing is tidying up joints to make them neater and more weather proof. This is important if the walls will NOT be plastered.

If the walls will be plastered, the mortar between bricks or blocks should be raked out to about 6mm deep before it sets. This makes a groove which helps the plaster stick to the wall.

Mortar should be raked out before it dries completely.

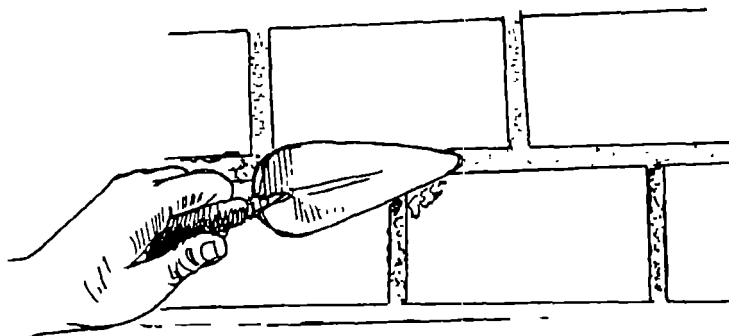

KEY POINTS

- a good bricklayer will always produce neat mortar joints of constant thickness
- always have an ant guard in your building at slab level
- always start walls at corners
- the first 2 courses must be accurate
- use brickforce every 600mm to strengthen the walls
- build wire ties into the walls for fixing down the roof

Frames and Lintols

Choosing the door and window frames

Fitting door and window frames

Lintols

Burglar bars and grill doors

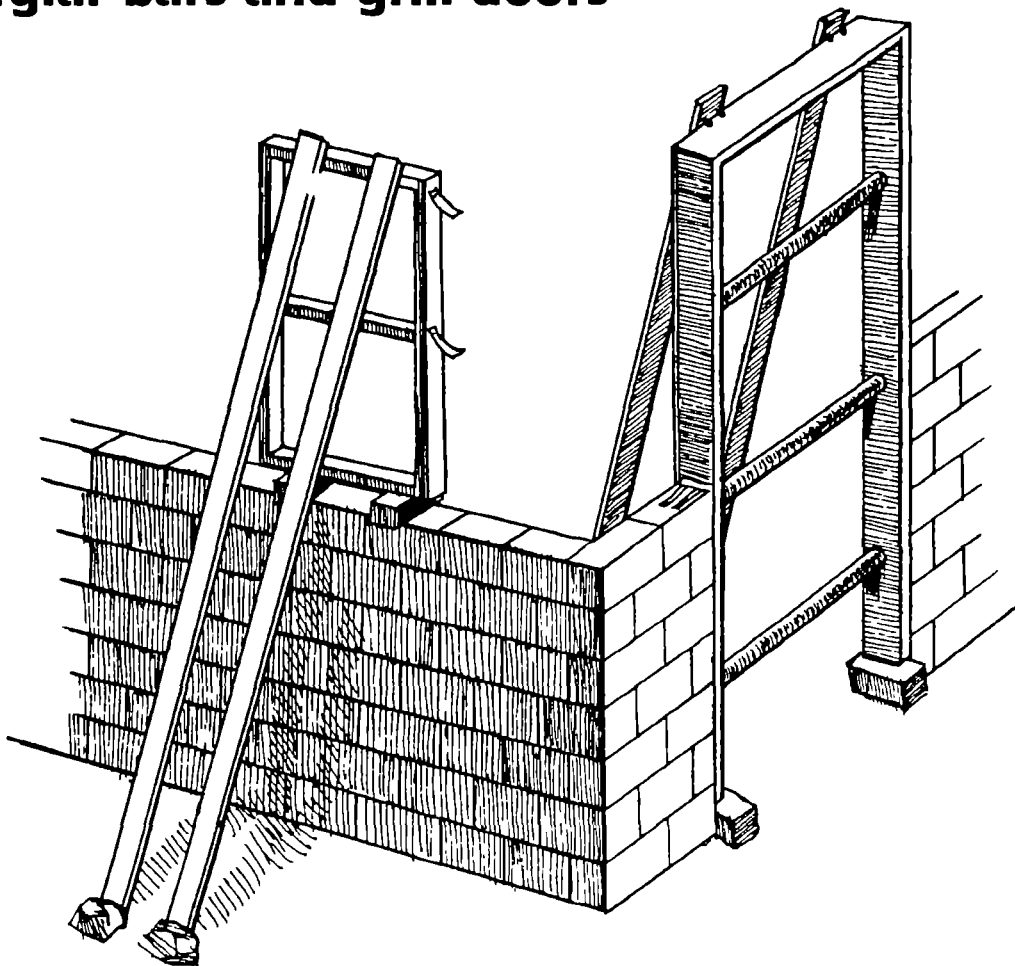

METAL FRAMES OR WOODEN FRAMES?

You have the choice of fitting metal or wooden frames for doors and windows.

Metal frames will last longer, but will cost more. Make sure they are well painted to protect them.

Wooden frames can be made locally. They should be much cheaper, but will not last as long as metal ones unless they are good quality hardwood and well looked after.

Wooden frames are less attractive to thieves.

Make sure wooden window frames are repainted every few years, or else water will get into them and they will split and rot.

HINT - You do not need to fit metal door frames to some doors, such as toilets or internal doors. Treated wooden frames are perfectly acceptable and will save your project many thousands of Kwacha.

WHEN TO FIT DOOR AND WINDOW FRAMES

Normally, door and window frames are set in place and the walls built around them. The frames are propped up until they are firmly fixed into the walls.

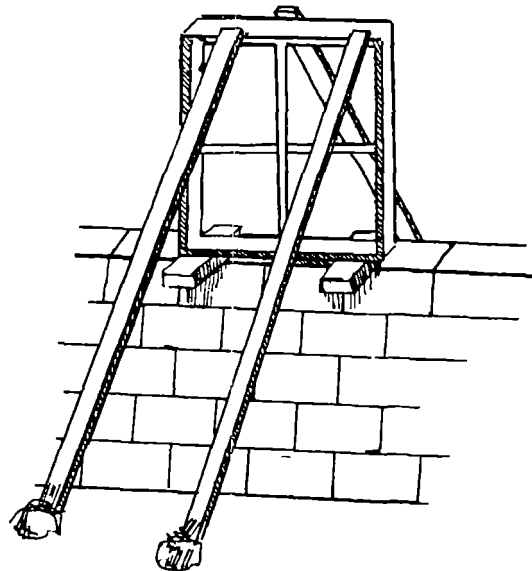
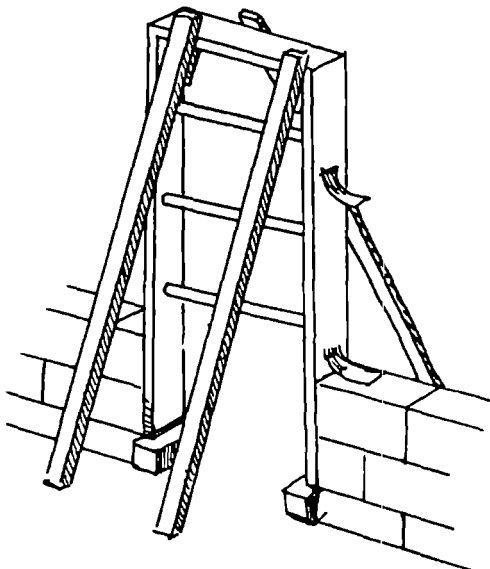

Door frames will bend as the walls are being built. If this happens the door will not fit properly, so the door frame must be supported by 3 pieces of accurately cut timber.

If your project is in an area where theft is a problem the frames could get stolen before they are fixed into the walls. In this case complete the walls first.

If the frames are fitted later, the right sized gaps must be left in the walls. The gap should be equal to the width of the door frame, plus about 12mm on either side for fixing it in place.

FIXING DOOR AND WINDOW FRAMES IN PLACE

Most commercial door and window frames have metal strips, locally called hoopers, attached. These are bent back and built firmly into the nearest brick course.

If this is not done, the frame will become loose in time.

Think about which way the doors are to open. The frames must be fitted the right way round.

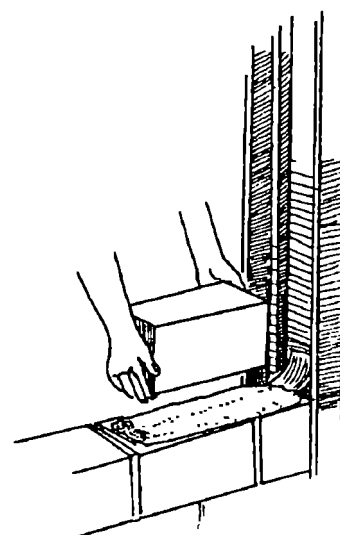

GLASS OR FANCY BLOCK?

You should have already agreed with your Regional Officer whether you are going to fit glass or fancy block windows. Did you consider the following points? If not, discuss them with your committee and Regional Officer and choose the best option for your project.

(1) GLASS

-Most people prefer the look of glass. Glass windows can be opened for ventilation.

-Glass is easily broken and is often stolen. It is VERY expensive to replace. If you use glass, you have to be very careful to protect it and replace it as soon as it gets broken. If you do not do this, very soon your building will look old and untidy.

-Use windows with lots of small glass panes, rather than one large one. A small pane is cheaper to replace when broken.

-The community **MUST** be willing to pay for repairing the glass that will get broken in the future.

(2) FANCY BLOCKS

-Fancy blocks do not let in as much light as glass. They cannot be opened to increase ventilation, nor closed to keep out dust.

-They are very cheap to maintain since they will rarely be broken.

HINT -If you are putting clear sheets in the roof, paint them with a thin layer of white or pale coloured paint. This allows the light to get in, but will stop the room getting too hot

-If you are using fancy blocks, MPU designs include a number of clear plastic sheets for the roof to increase light.

-If your community is in an area where vandalism is a problem, or where the community has not much money, you are strongly recommended to use fancy blocks.

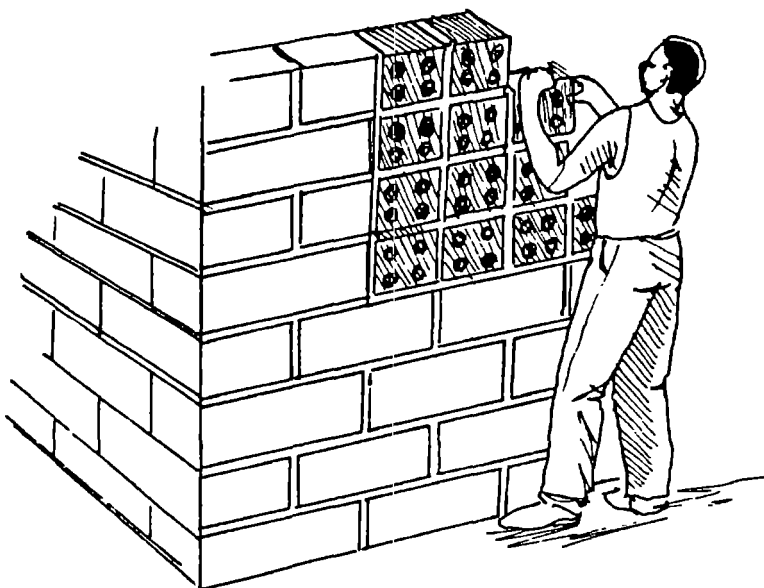

If you are using decorative or fancy blocks, the blocks should be built in as the wall is being constructed. This is easier than trying to fit the fancy blocks when the wall is complete.

WINDOW CILLS

A window cill must be fitted to each window to drain water away from the window and walls.

You can use either a pre-cast cill or make your own using bricks on their edge.

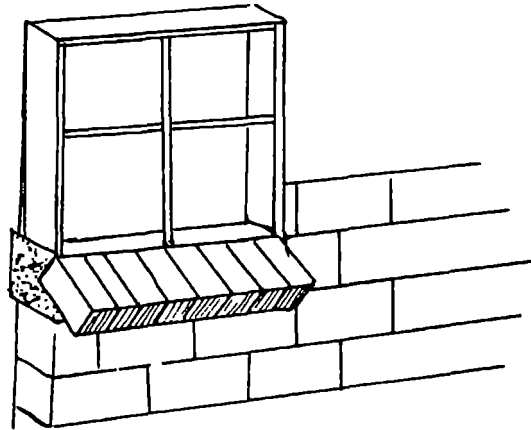
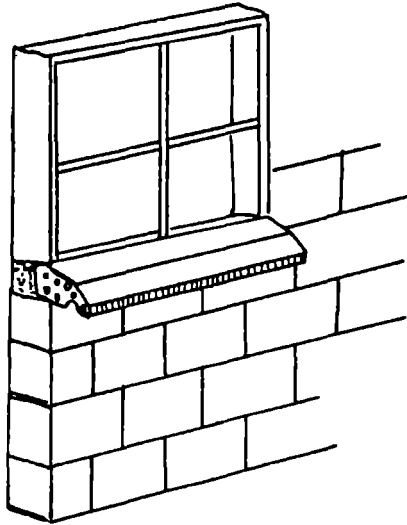

The groove underneath the cast cill forces the water to drip off. The groove can be made by laying a piece of rope or shaped wood in the mould.

LINTOLS

Door and window openings make the wall weaker, so a support is needed above EVERY door and window to make the wall strong again. These supports are called LINTOLS (which can also be spelt LINTEL).

A poor lintol will sag and crack, because of the weight of the wall above it.

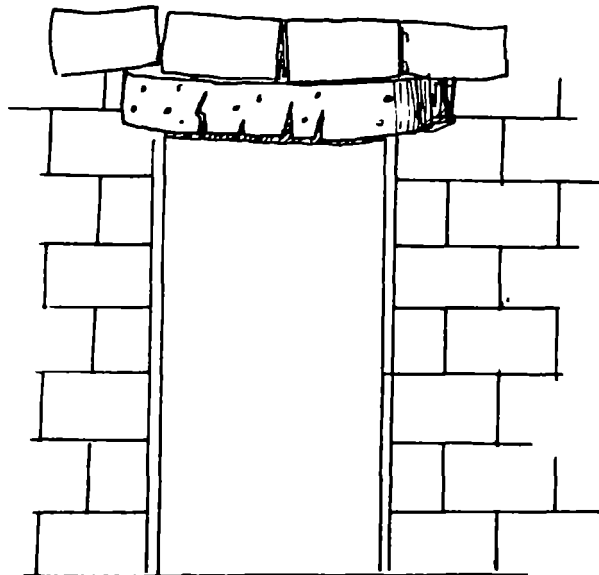

POOR LINTEL

The best lintols are made from reinforced concrete. There are 2 types:

(1) CAST IN-SITU LINTOLS

If the lintol is cast in-situ, it is made in position above the door or window opening.

The advantage of this method is that it is easier to make the lintols fit the opening accurately. These lintols are also slightly stronger, so you should consider them for very large windows.

The disadvantage is that it slows down the building work. The builders have to make the shuttering, pour the concrete and leave it to cure before they can continue with the courses above the lintol.

(2) PRE-CAST LINTOLS

HINT -You can pre-cast the lintols at the same time as making the floor slab, since they are made from the same concrete mix.

A pre-cast lintol is one that is cast on the ground and lifted into position. These are specified on MPU plans.

The advantage of this method is that the lintols can be made and fully cured **before** they are needed. It is a simple matter to fit them to your building and there will be no delays in the building work.

MAKING A LINTOL

The best lintols are cast in a timber mould. When casting lintols in-situ the mould must be well supported on the wall.

Make the mould slightly narrower than the wall, since the mould will expand a little when the concrete is added. If the lintol is wider than the wall, it cannot be plastered.

The mould should be at least 300mm longer than the opening, so that there is at least 150mm of lintol "bearing" on each side.

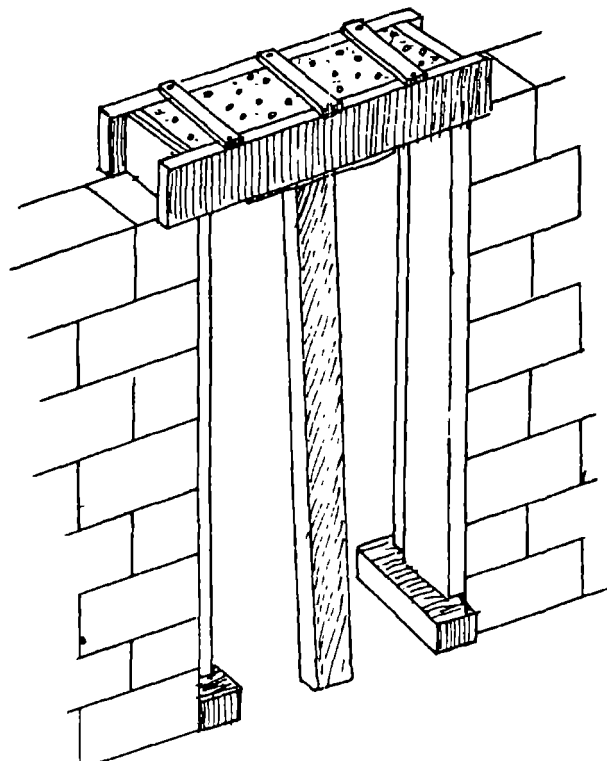

The rebar should be about 25mm above the bottom of the box. Use bar at least 10mm in diameter. Bend the end of the bar round to form a hook.

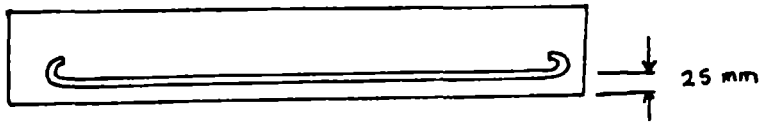

If the lintol is less than 1200mm long, 2 reinforcing bars are enough. If the opening is wider than this, 3 or 4 reinforcing bars should be used.

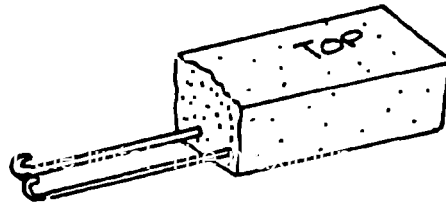

see
page 42

A 1:2:4 concrete mix is used for the lintol. The maximum size of stones in the mix should be 25mm across (see page 42).

IMPORTANT

- make sure that the rebar is in the mould.

The concrete should be added to the mould and compacted by tapping it down with a suitable tool. Tapping the sides of the box also helps compact the concrete.

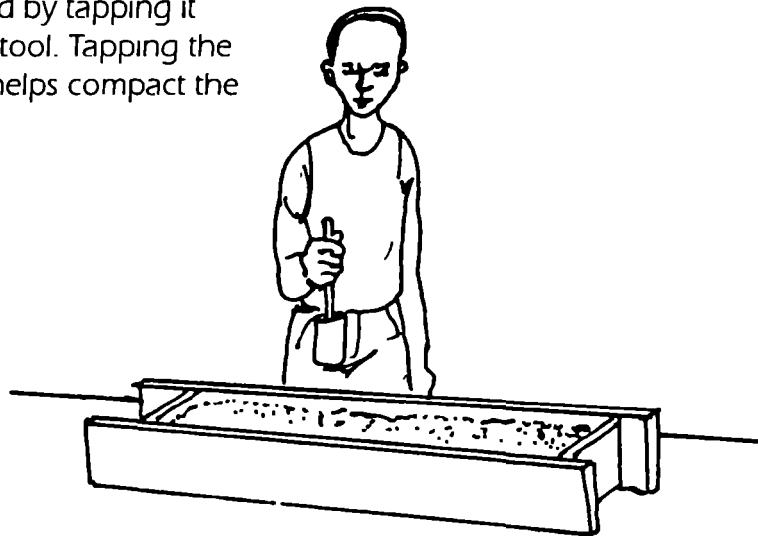

HINT - If you are making pre-cast lintols, mark the top of the lintol. It is easy to turn the lintol round and forget where the rebar is. The rebar MUST be near the bottom of the lintol.

BURGLAR BARS

If vandalism and theft are a problem in your area:

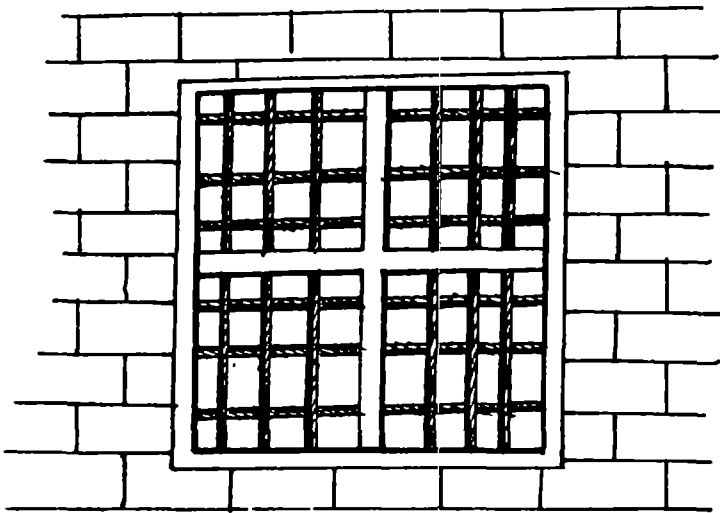

-Fit burglar bars and grill doors to all offices, ablution blocks or other rooms with expensive equipment.

-Consider casting burglar bars into window cills and lintols, or fixing them into the walls as you build. This is the strongest type of construction. Be careful to check which way the windows open before fixing the bars on one side or the other.

-Some window frames come with burglar bars attached. Use these, or weld bars to your window frames.

-Make sure the burglar bars are welded BEFORE fitting the glass. The frame will bend slightly when it is being welded and this can break the glass.

-Weld the bars to each other for added strength.

-Use good quality "moon" type padlocks on grill doors

-Protect the locks with metal cylinders.

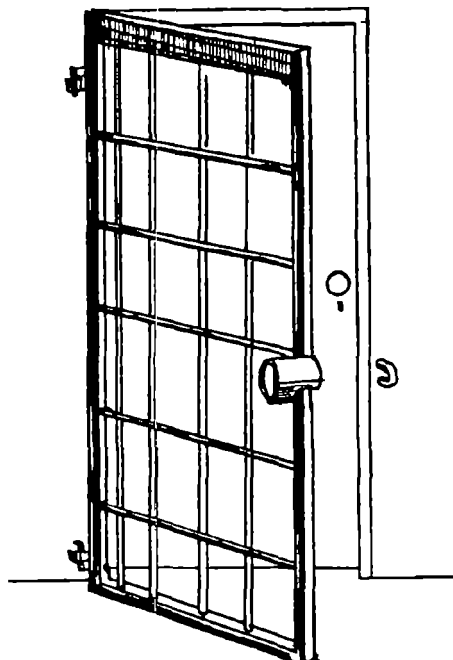

KEY POINTS

- *it is best to build door and window frames into the walls as you are building, unless theft is a problem in your area*
- *ALL doors and windows must have reinforced concrete lintols above them*
- *take time to choose the most appropriate doors and windows for your project*
- *if necessary, fit secure burglar bars and grill doors to combat theft*

Roofing

- Choosing and storing the timber
- Different types of roof
- Planning the roof
- Constructing the roof

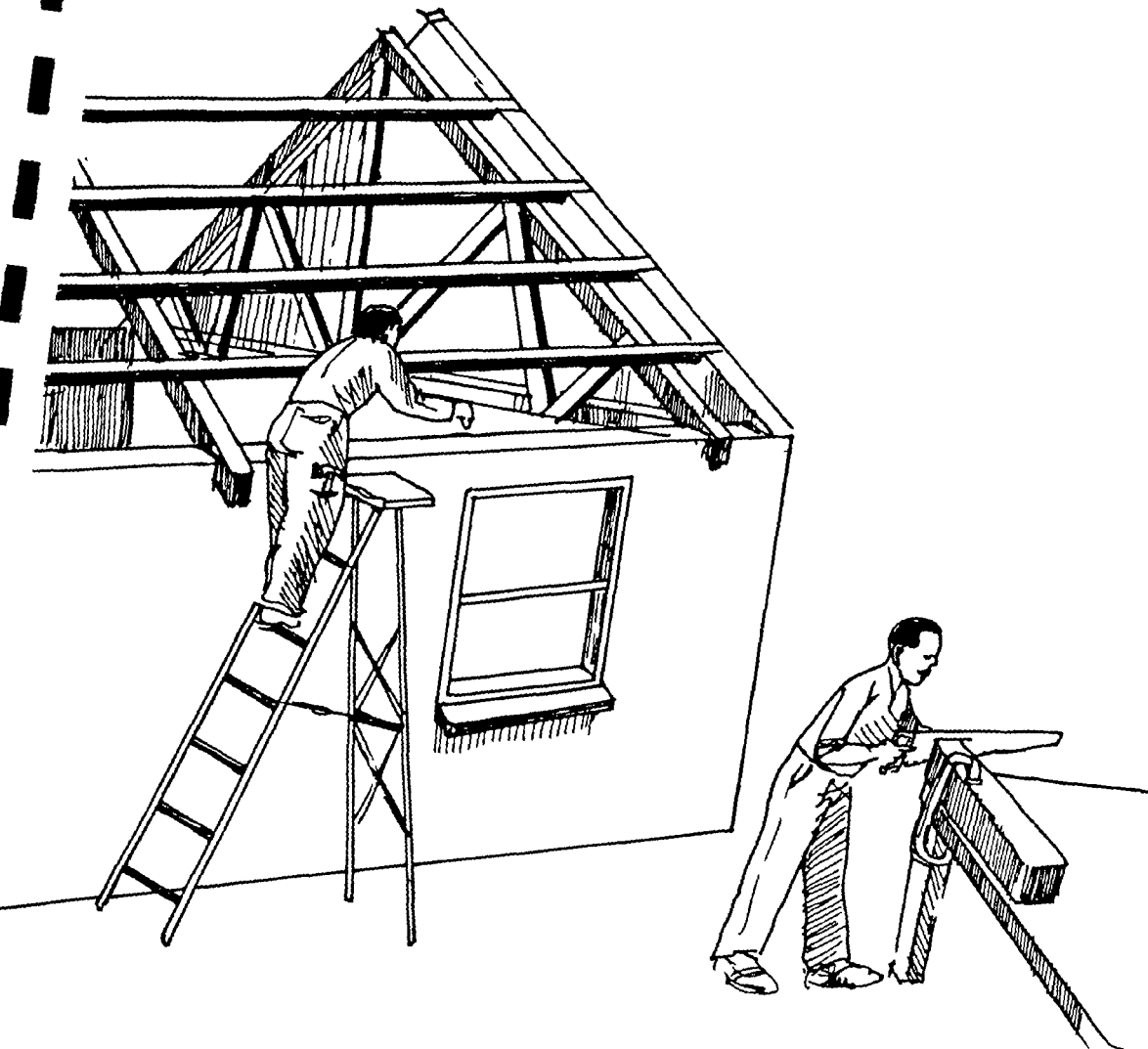

INTRODUCTION

The main parts of a roof are shown in the illustration.

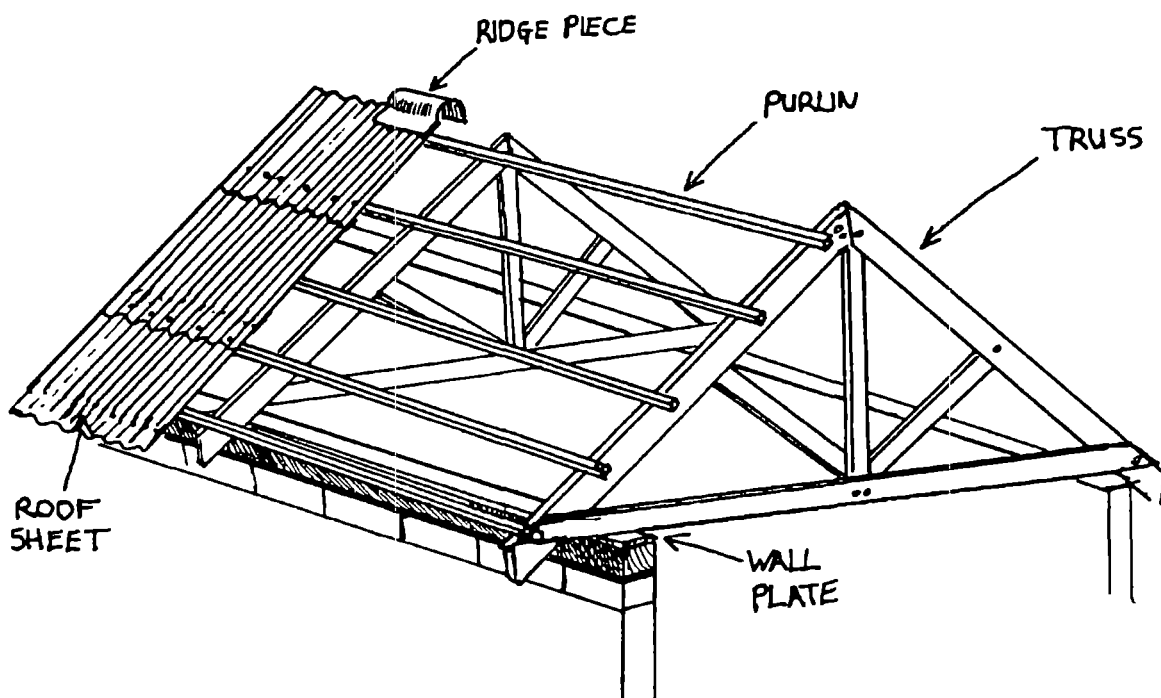

Wall Plate - The top layer of bricks in the wall is covered with a plank called a WALL PLATE. The roof is attached to the wall plate.

Trusses - are used in larger buildings.

Purlins - the roof sheets are attached to purlins.

Ridge Pieces - give a waterproof cover to the middle of the roof.

Constructing a good roof is not a simple job. It requires both skill and great attention to detail, especially when laying Asbestos Cement (A/C) sheets.

If you do decide to use A/C sheets, make sure your Supervisor obtains a copy of the TAP "Instructions For Fixing" for the type of sheets you are using BEFORE you start. These instructions are available free from

TAP Building Products Ltd
 Chester House
 Cairo Road
 PO Box 31522
 Lusaka
 Telephone 211705

Talk to your Supervisor and be sure that either he or the carpenter is able to build the roof well. Many roofs have been ruined by poor workmanship.

TIMBER

Every roof contains a lot of timber. It must be chosen and stored with care

(1) Seasoning

ALL fresh timber contains a lot of water. As the timber dries it will shrink. If it is not stored correctly it will also bend and twist. This is called WARPING.

The drying process is called SEASONING Try to buy well seasoned timber

NEVER use freshly sawn timber

HINT -You should try to buy timber very early in your project It can then be left to dry while you are doing other work

(2) Choosing Your Timber

Always know what type and sizes of timber you require

Take your Supervisor or carpenter with you when you are buying timber and ask their advice

You might find more choice of wood at a pit sawyer, but if you go to a sawmill you will probably get more uniform pieces.

Check the timber carefully before you buy it.

Look for knots and bad cracks in the timber All timber will have some knots, but reject pieces that have many - they make the timber weak.

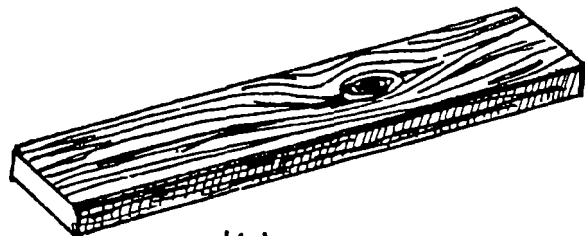

**KNOTS IN TIMBER
MAKE IT WEAKER**

Check for splits in the wood that occur because of seasoning

Check to see that the wood is free from insect damage or disease

(3) Storing Timber

The timber will continue to season after you have brought it to the building site. Store it carefully to prevent it warping.

-Clear the area where the timber will be stored. Sprinkle ash around the area to keep termites away.

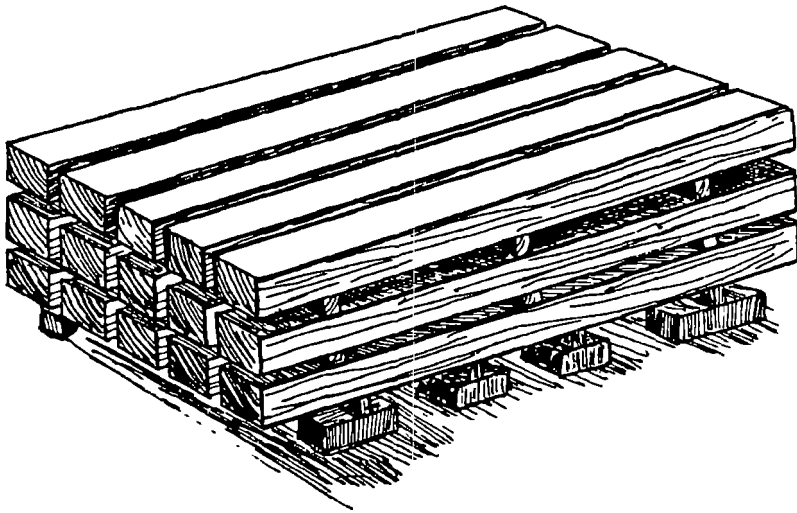

-Place blocks on the ground to raise the bottom layer of timber off the ground. Make sure the blocks are level, or they will cause the timber to twist.

-Build the timber into stacks. Separate each layer of timber to allow air to circulate.

-Protect the timber from the sun and rain. Keep the stack covered.

(4) Ant Treatment

Whatever type of roof you are making, remember to soak ALL timber with creosote or carbolineum.

HINT - Heating the creosote improves its penetration into the wood.

This is essential or else your roof will be attacked by termites.

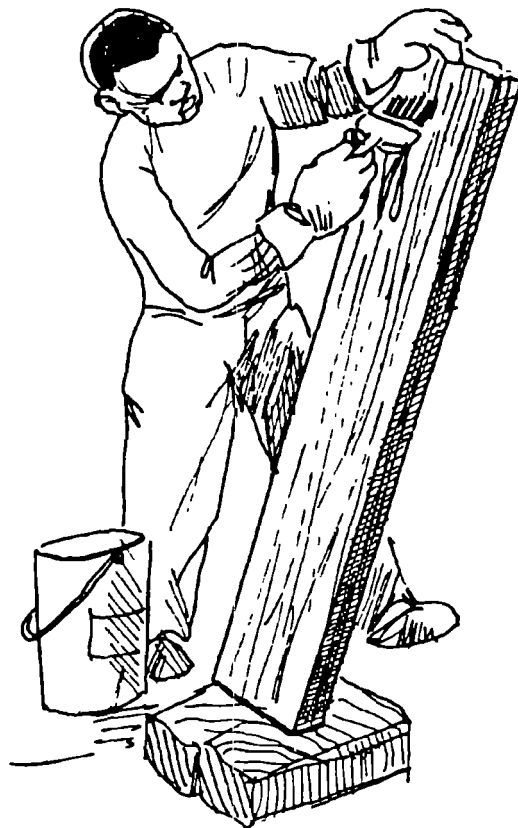

TYPES OF ROOF COVERING

There are a number of different roof coverings. Use the type which best suits your project. Ask your Supervisor, Buildings Officer and Regional Officer for advice. The main types are:

Asbestos Cement (A/C) Sheets

A/C sheets are relatively cheap and commonly available, but are easily damaged. If the roads to your project are bad, many sheets can be broken in transit. Sheets are also easily broken when being fitted, handled or stored

It is VERY difficult to remove A/C sheets without breaking them, so they often cannot be reused. If one sheet is damaged, several others may be broken when trying to remove the first one.

Galvanised Iron (G.I.) Sheets

These are easier to transport, more difficult to damage and will probably last longer than A/C sheets. They can be removed and re-used.

However G.I. sheets are more expensive than asbestos and are more attractive to thieves. If theft is a problem in you area, it may be better not to use them.

G.I. roofs make a room feel hotter than asbestos roofs, so the inside of the building may become uncomfortably hot if there is not enough ventilation

Tiles

If tiles are being made locally they should be cheaper than either G I. or A/C sheets. However more timber is required in tiled roofs, so the overall costs have to be carefully calculated.

It takes many more tiles than sheets to roof a building so tiles are less attractive to thieves, especially if each tile is wired down individually

One damaged tile is much easier and cheaper to replace than a damaged or stolen roof sheet.

If you want to use tiles, MPU can supply the instructions you need

We will concentrate on roof sheets in this book, because they are the most common.

PLANNING THE ROOF

Roofing sheets come in different sizes. You must PLAN your roof in advance, to decide:

- what lengths of roof sheet to buy,
- how many of each size to buy,
- the number and spacing of purlins to suit these sheets.

Use experienced men to calculate the right combination to suit your roof. Draw sketches of the roof to help in planning. Consider the following things.

(1) Lengths of Sheet

When calculating the lengths of roof sheet required:

- allow an overhang of 300mm at the bottom of the roof.

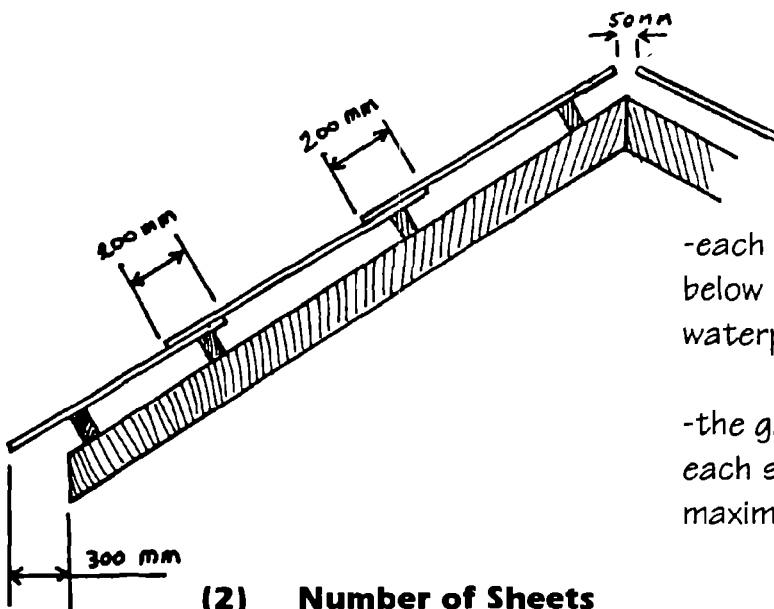

-each sheet must overlap the one below by about 200mm to ensure it is waterproof in heavy rain.

-the gap between the top of sheets on each side of the roof should be 50mm maximum.

(2) Number of Sheets

-allow for an overhang of 100mm at each end of the building.

-allow for an overlap of at least 1 1/2 corrugations between sheets, to ensure the joints are waterproof.

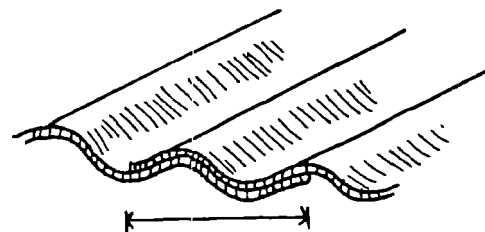

1 1/2 CORRUGATION OVERLAP

IMPORTANT

NEVER have an overlap of less than 1 1/2 corrugations between sheets

(3) Number and Spacing of Purlins

The ideal distance between purlins must be based on the size of the roof and the sheets you are using

The maximum recommended spacing between purlins is 1100mm.

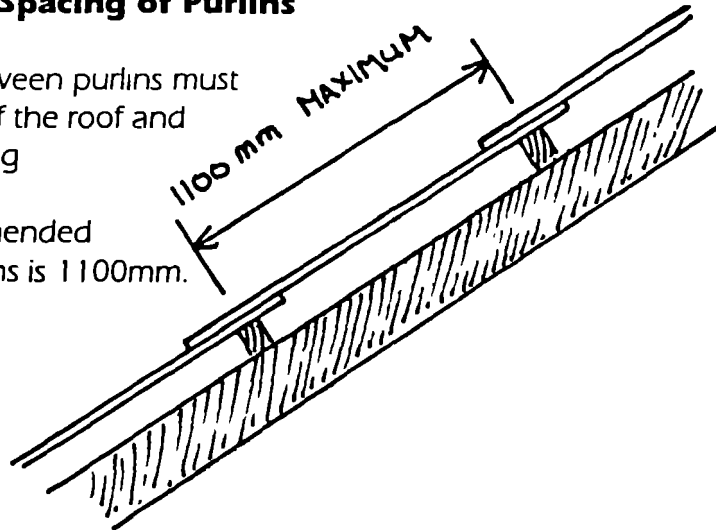

The top purlins must be close enough for the ridge piece to be fixed to it.

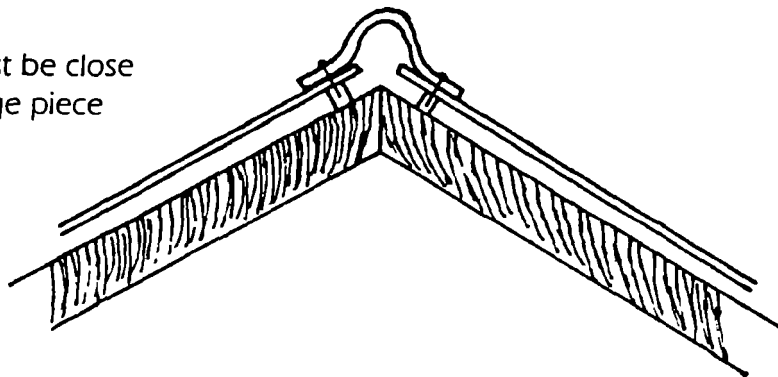

CONSTRUCTING THE ROOF

(1) Wall Plate

MPU plans state that wall plates should be 100mm x 50mm in size

The wall plate must be securely fastened to the wall. It is pressed into a mortar bed.

When the mortar is firm, the wall plate can be nailed to the mortar to stop it moving sideways

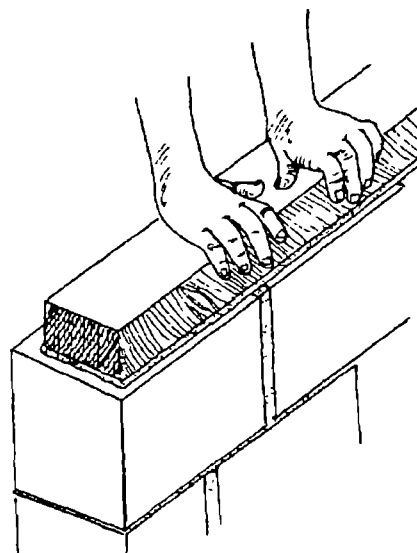

A good wall plate joint is shown in the sketch

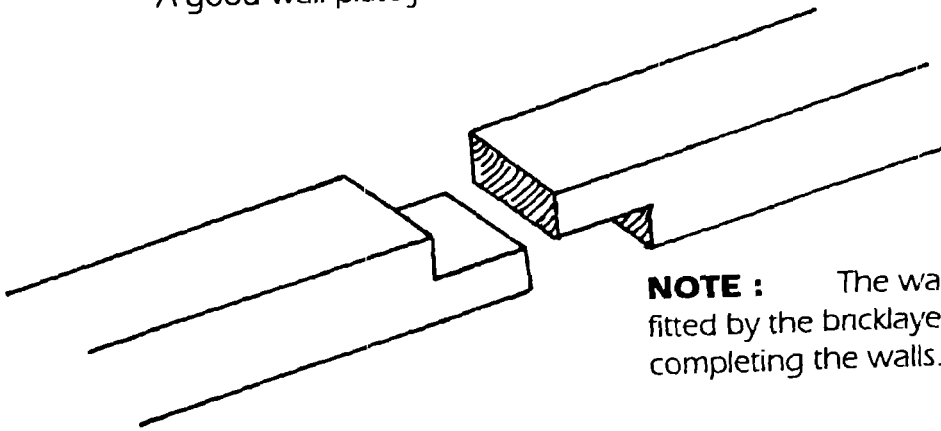

NOTE : The wall plate is normally fitted by the bricklayers as the last job in completing the walls.

(2) Trusses

Trusses should be spaced a maximum of 1500mm apart

Trusses are constructed on the ground and lifted into position. There are many different designs of truss. A good example is shown in the illustration.

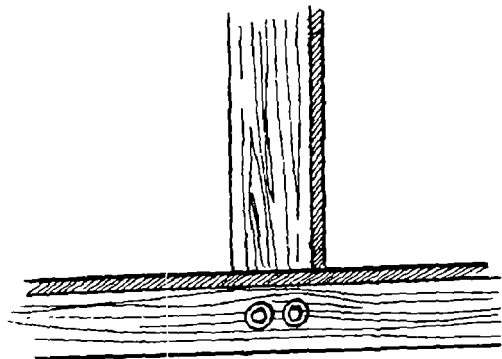
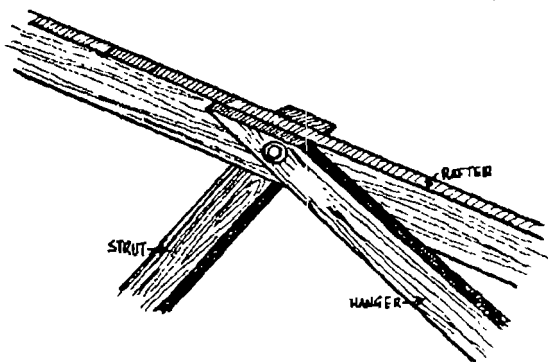
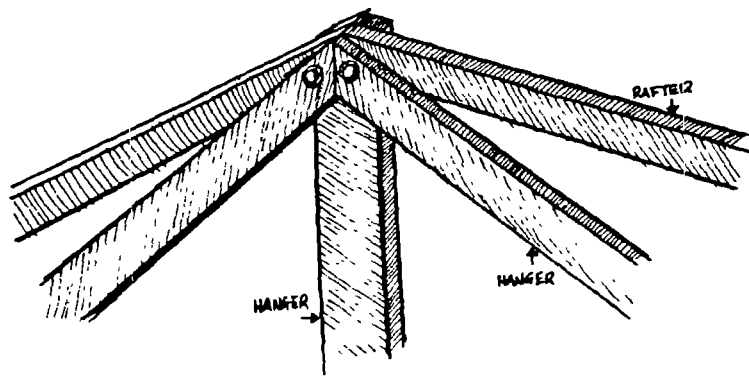
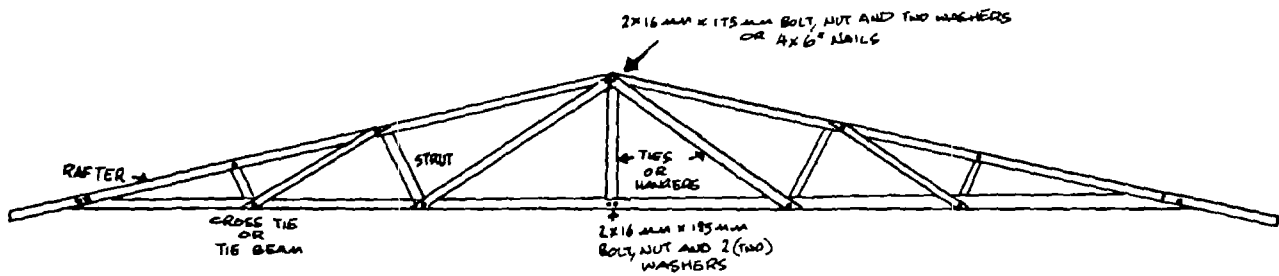

MPU plans specify trusses are made from 150mm x 50mm timber.

All joints must be strong. Two good joints are shown in the illustration.

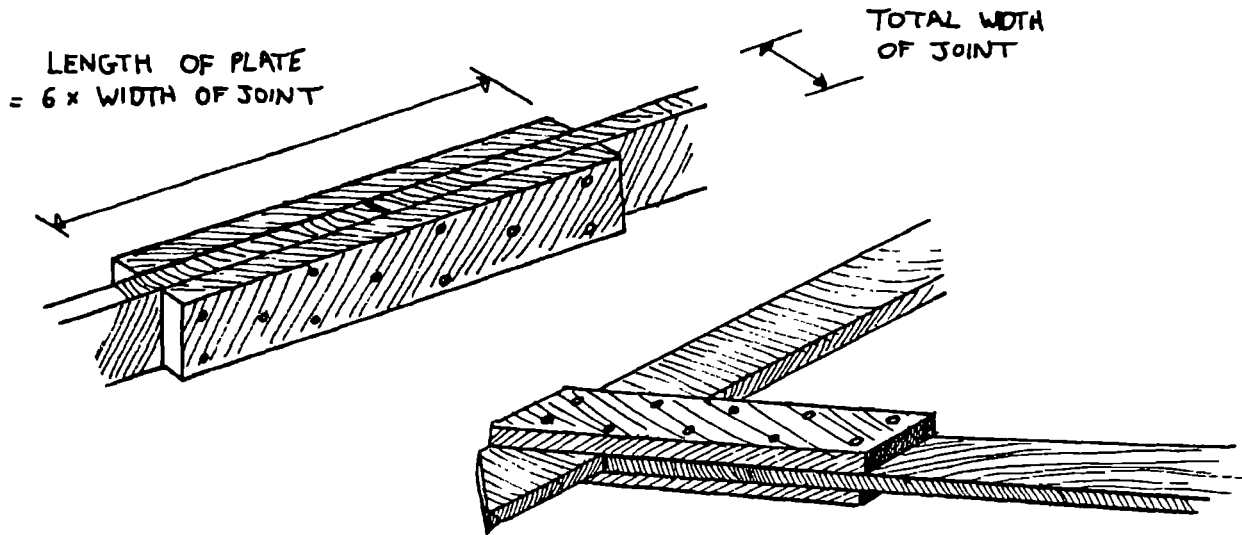

If the truss looks twisted it is a poor truss. It will make the rest of the roof difficult to construct accurately. Trusses must be straight and installed exactly vertical.

Gum Pole Trusses

If you cannot get good timber for the trusses you can consider making gum pole trusses, but they must be well made.

A good gum pole truss is shown in the illustration.

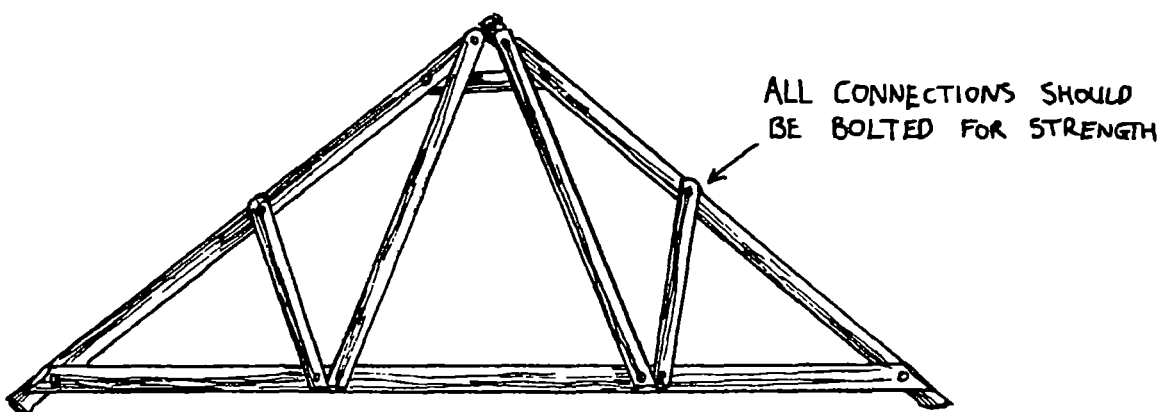

Remember, if you want to use gum poles or any other local alternative, you must have the written permission of your Regional Officer first.

(3) Purlins

MPU designs specify 75mm x 50mm purlins. They must rest on their NARROW edge.

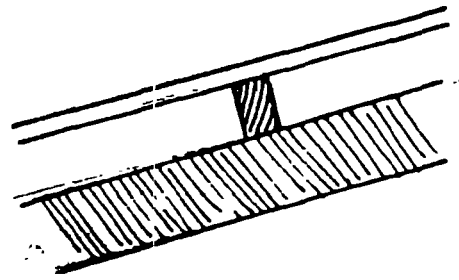

Remember, the MAXIMUM spacing between purlins should be 1100mm.

It is important that the purlins are level and square to the roof covering. If the purlins are not quite straight, they can be adjusted by fitting spacing blocks. If the roof has been made accurately it will need fewer spacers.

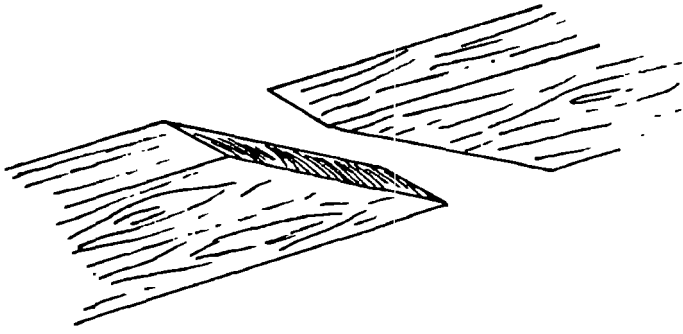

It is recommended that each purlin joint is made over a truss. A good purlin joint is shown in the sketch.

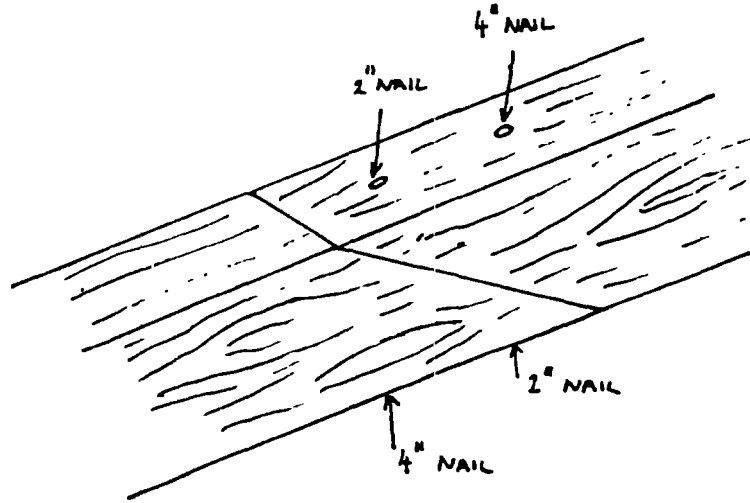

(4) Buildings Without Trusses

Smaller buildings do not use trusses

In some buildings the purlins are supported by the walls. If possible, make the purlin joints rest on internal walls

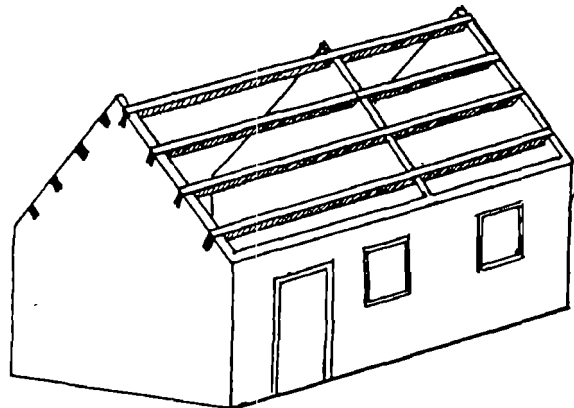

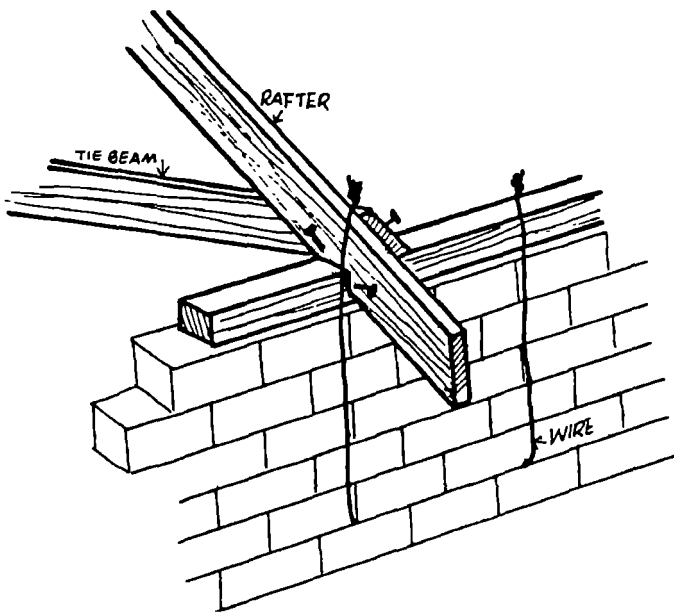

Other buildings use rafters, which are similar to trusses but are easier to make. The rafters and the tie beams are fixed directly on to the wall plate.

(5) Roof Connections

Make sure all roof timbers are securely fixed to prevent wind lifting the roof

see
page 104

Tie timbers down securely using the wire ties built into the walls (see page 104).

When nailing the roof timber to the wall plate, the nails should go in at an angle (called skew nailing) to make a strong connection.

Tie or skew nail purlins to trusses and rafters at every joint.

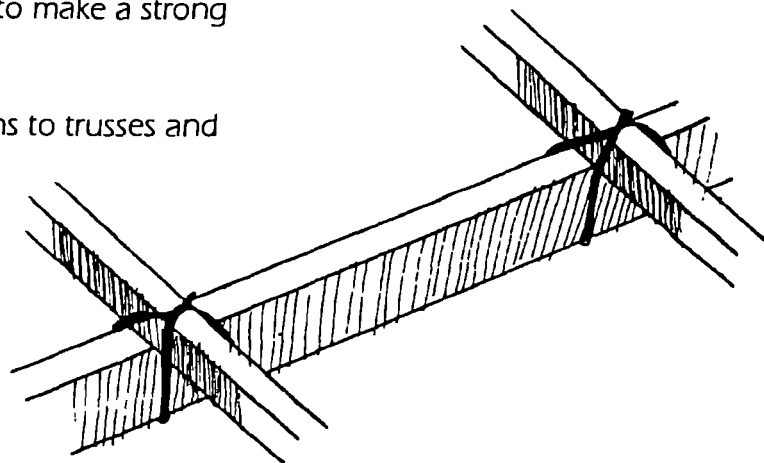

HINT -Start by lightly fixing all trusses, rafters, purlins, etc. in place to check everything lines up accurately. Fix roof members permanently only after completing this check.

Where roof timbers go through holes in the wall, it is better not to plaster the timber in tightly. The mortar or brickwork will crack if the timber twists slightly.

(6) Mitring

Mitring means cutting the corner off something to make it fit. Roof sheets, especially AVC sheets, should have some of their corners mitred. Which corners are mitred depends on which order the sheets are laid.

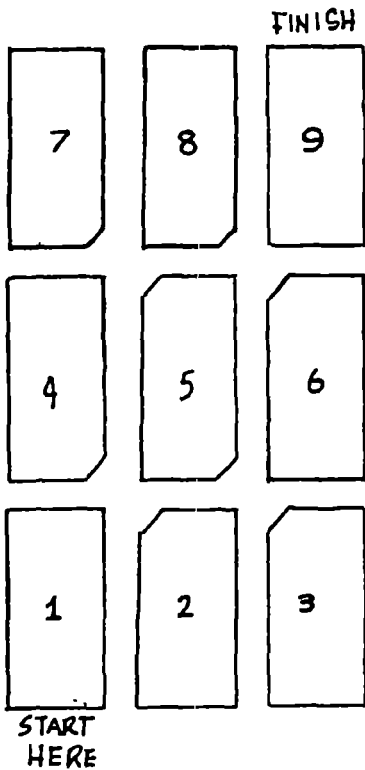

CORNERS TO BE MITRED
- LAYING LEFT TO RIGHT

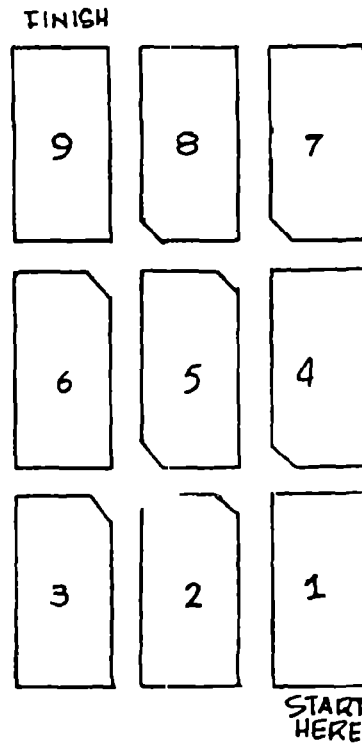

CORNERS TO BE MITRED
- LAYING RIGHT TO LEFT

(7) Fixing Roof Sheets

Care should be taken to lay roof sheets neatly. Check that edges are straight and level.

You must fit two washers to each roof sheet.

- a metal one,
- a soft one, made of felt or rubber, which stops leaks. The soft washer should be slightly smaller than the metal one.

NOTE : NAIL THROUGH THE TOP OF THE CORRUGATIONS TO AVOID LEAKS

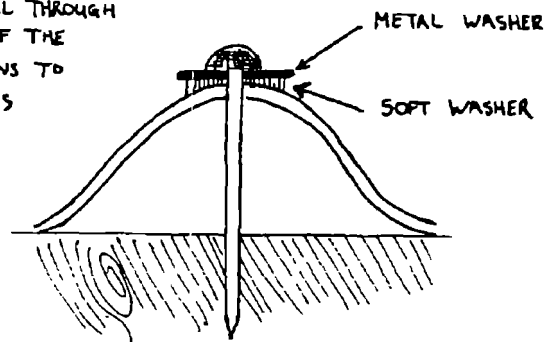

Proper roofing nails should always be used. A hole should be made in the sheets before driving in the nail.

If the nail bends and has to be removed, the hammer should be supported using a shaped stick bedded in sand, as shown in the illustration. This spreads the load on the sheet and helps stop it being damaged. Also do this if the sheets ever have to be removed.

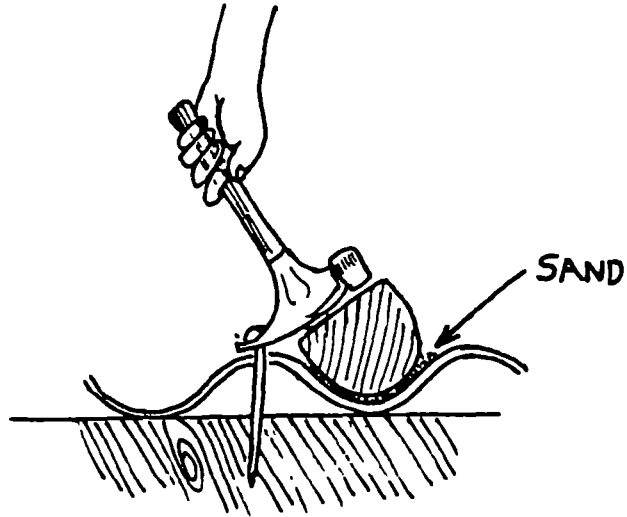

IMPORTANT

Take great care when nailing or cutting roof sheets, especially *AVC* sheets. They are very easily damaged and you must wear a mask to prevent you breathing any *AVC* dust.

(8) The Ridge

The ridge of the roof is covered by *RIDGE PIECES*. Make sure there is a good overlap to the top roof sheets and the ridge pieces are firmly fixed to the top purlins.

KEY POINTS

- never use freshly sawn timber
- choose the most appropriate roof covering for your project
- plan your roof **IN ADVANCE**
 - size of sheets
 - number of sheets
 - spacing of purlins
- ensure all timbers have good secure joints
- tie all roof timbers down securely



Plastering, Painting and Finishing

Good plastering

Types of paint to use

Glass

Doors

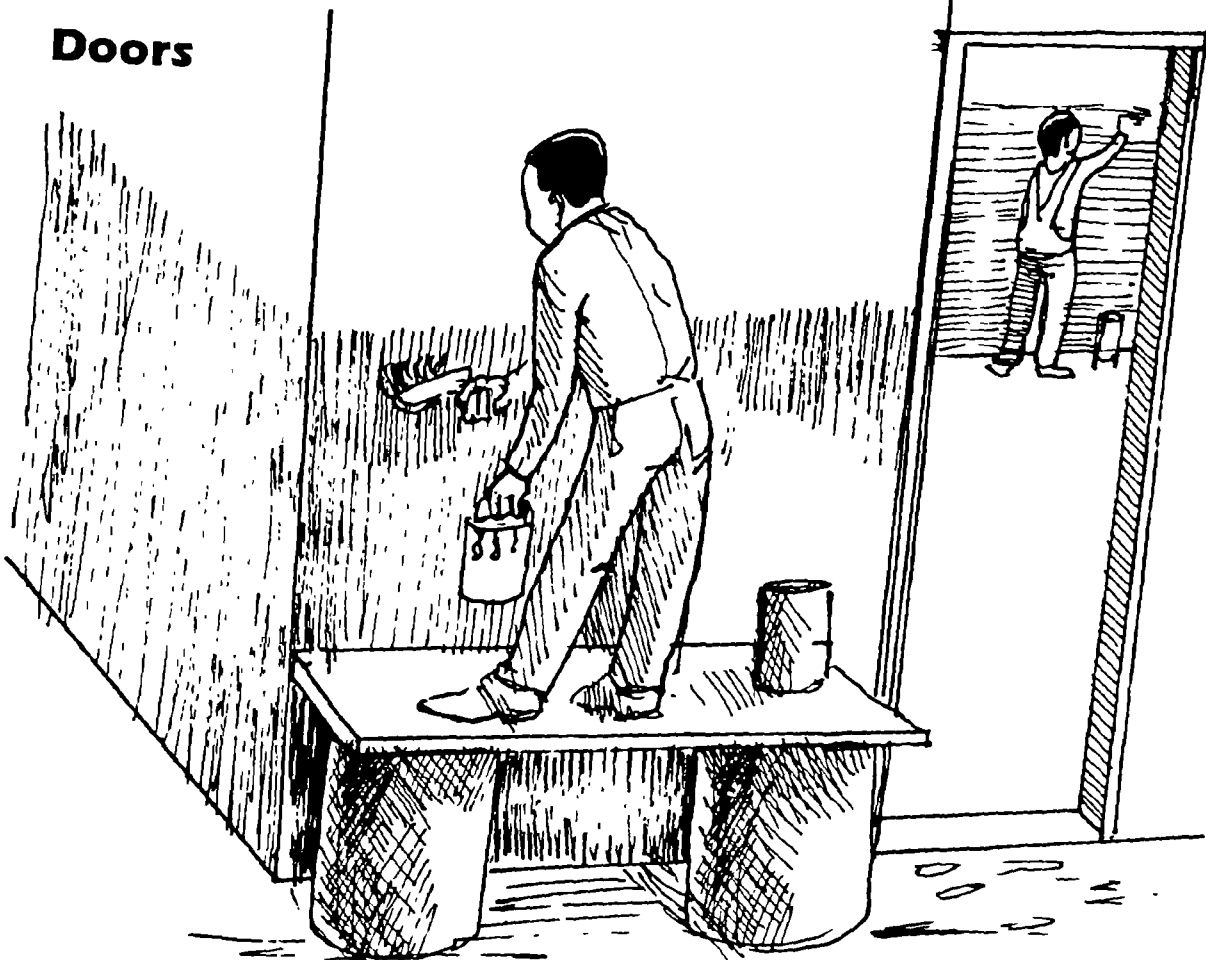

PLASTERING

Plaster can be applied to:

- outside walls to stop water penetrating to the brickwork,
- inside walls to make them look attractive, easy to paint and easy to clean.

Good plaster will have no gaps or cracks and should stick well to the walls

WHEN TO PLASTER

All new buildings will move slightly as they dry out or the foundations settle. This is perfectly normal and you do not usually have to worry.

However, if walls are plastered as soon as the building is finished, the plaster may crack because of this movement.

It is better not to plaster until the building has settled. This can take several weeks.

You may not be able to wait this long, but try to wait as long as possible. Build other targets if you have any and then come back to finish the plastering.

This will reduce the number of cracks that appear in your plaster.

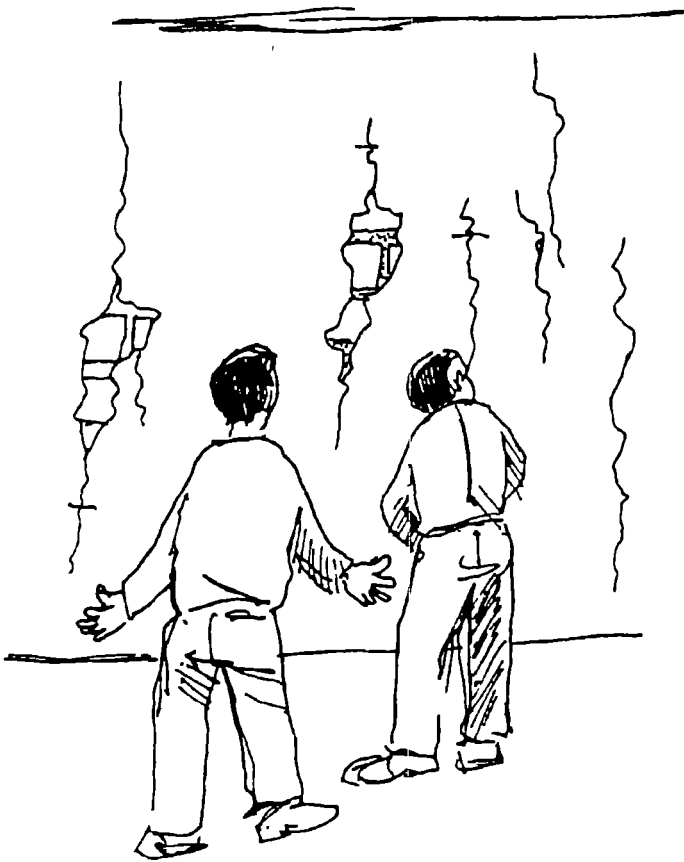

APPLICATION OF PLASTER

Two thin coats will last longer than one thick coat. It will take longer to do this way, but the results are worth it. Discuss it with your Supervisor.

-Any holes or hollows in the wall should be filled and any projecting bricks chiselled off.

-All loose dirt and dust must be cleaned from the walls.



-The walls should be dampened well before applying plaster, to stop the walls absorbing moisture from the mortar.

-Plastering should always start at the top of the walls and work downwards.

-A board should be laid at the bottom of the wall, to catch any mortar that drops. This can be used again, provided it is still fresh.

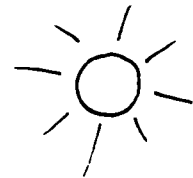

External walls should be plastered when they are not in the full sun

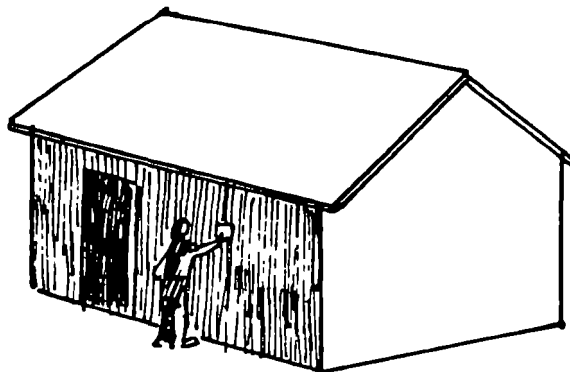

Plaster must be applied evenly and to the correct thickness.

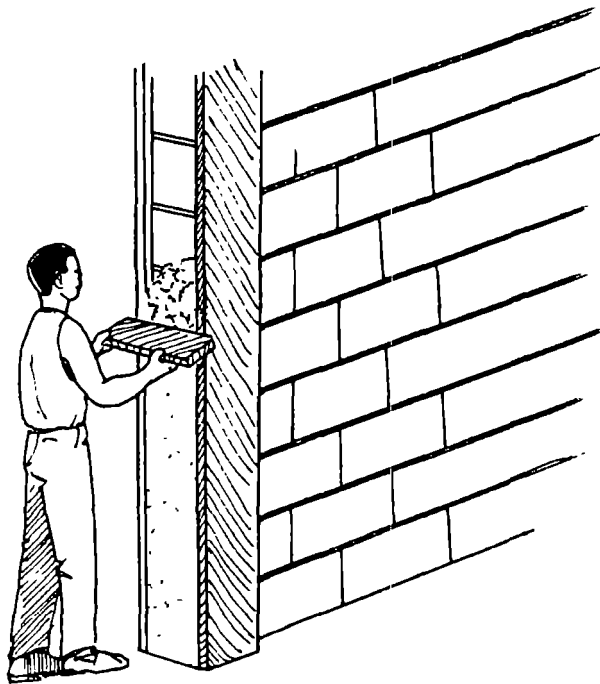

On outside corners this is done by using **EDGE BOARDS**. These are fixed so that they project past the end of the walls by the desired thickness of plaster.

On inside walls, the best plasterers will:

-apply the plaster,

-use a straight edge or a long wooden float called a **DARBY** to flatten any high spots,

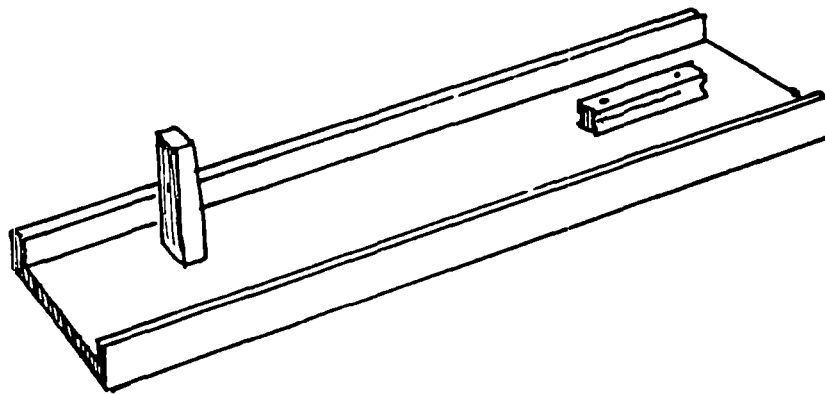

-go over the surface with a wooden float,

-finish off with a metal plasterer's trowel. This has an edge up to 12" long. A normal trowel is too small.

Another method is to prepare **SCREEDS**

-A screed is a strip of mortar, carefully applied so that the finished surface is perfectly vertical.

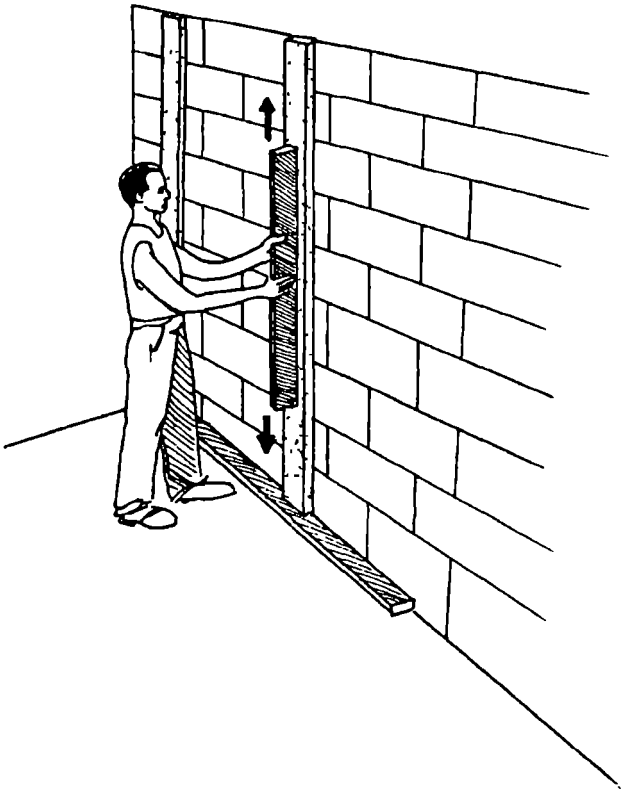

-The screed is smoothed by moving a smooth, flat plank vertically up and down over it.

-The screeds are used as a guide for the application of the rest of the plaster.

If two coats of plaster are being used, let the first coat dry for a few hours then scratch the surface with nails hammered through a plank of wood. This gives a better surface for the second coat to stick to.

Sprinkle the surface with water before applying the second coat.

JOINTS

Wherever possible, an entire wall should be plastered in one go.

If this is not possible, any joints on outside walls should be made to face downwards.

A timber guide fixed to the wall will help make neat joints that face downwards.

Plastering should never finish at a corner. The plasterer should continue plastering at least 150mm past the corner.

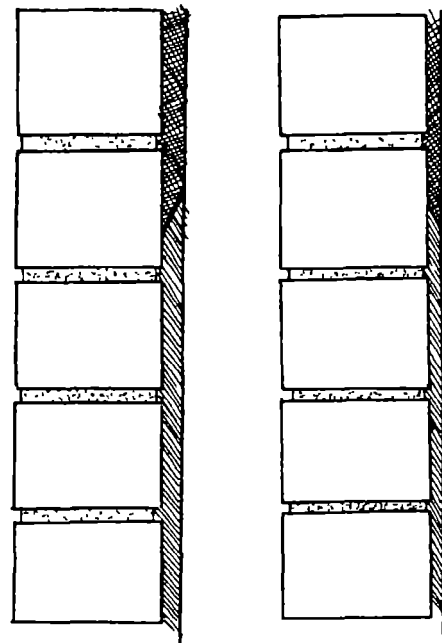

POOR JOINT GOOD JOINT

CURING

Like concrete, plaster has to be left to cure

Keep the plaster damp for about 1 week after finishing, especially walls that are in the sun. If you do not do this, the plaster will dry out too quickly and you will get large cracks.

PAINTING

TYPES OF PAINT

- Primer:** This is the first coat. It is used to seal the surface
- Undercoat:** It is used to give the wall a base colour and prepare the surface for the top Gloss coat
- Gloss:** This is an oil based paint. It is more expensive than water based paint, but the painted surface is easier to clean
- PVA:** This is an emulsion paint, which means it is a water based paint. It does not need separate primer or undercoat

HOW MANY COATS?

NEW PAINTING
= 3 COATS

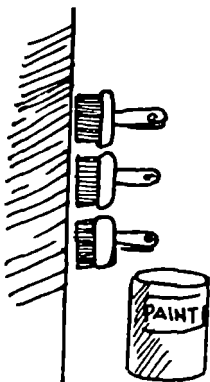

REHABILITATION
= 2 COATS

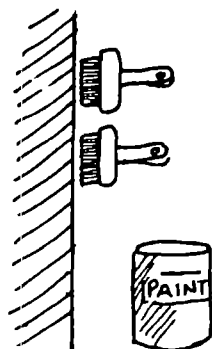

NEW PAINTING:

Walls being painted for the first time should have 3 coats: 1 undercoat and 2 top coats

New wood should be primed before the other coats

RE-PAINTING:

Walls that are being repainted usually just need 2 coats. Undercoat is not used unless the existing paint is very poor or there is to be a change of colour

HOW MUCH PAINT

As a rule of thumb.

-for new painting, one 5 litre tin of paint should cover 30m² of wall with one coat.

-for repainting, one 5 litre tin of paint should cover 40m² of wall with one coat.

However, this will depend on the surface and the quality of paint being used. Sometimes 5 litres will cover as little as 20m².

THINNERS

Read and follow the instructions on the tin of paint carefully, because some modern paints do not need thinning, or even stirring. If your paint needs to be thinned to make it easy to apply, then:

-water based paints can be thinned using water.

-oil based paints need proper thinners. If you cannot buy thinners, you can use kerosene although this is not so good. NEVER use diesel or petrol.

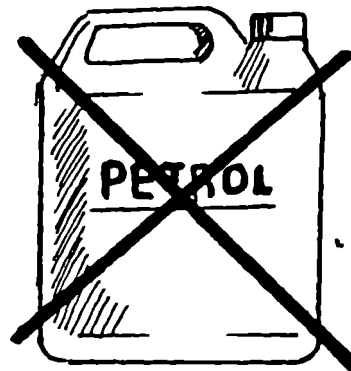

Many painters will thin the paint too much, which will result in a very poor finish. Paint should be thinned only enough to apply it evenly and smoothly.

Watch closely how much paint the painters are using. Theft is common, so the Supervisor must be vigilant.

WHICH PAINT TO USE

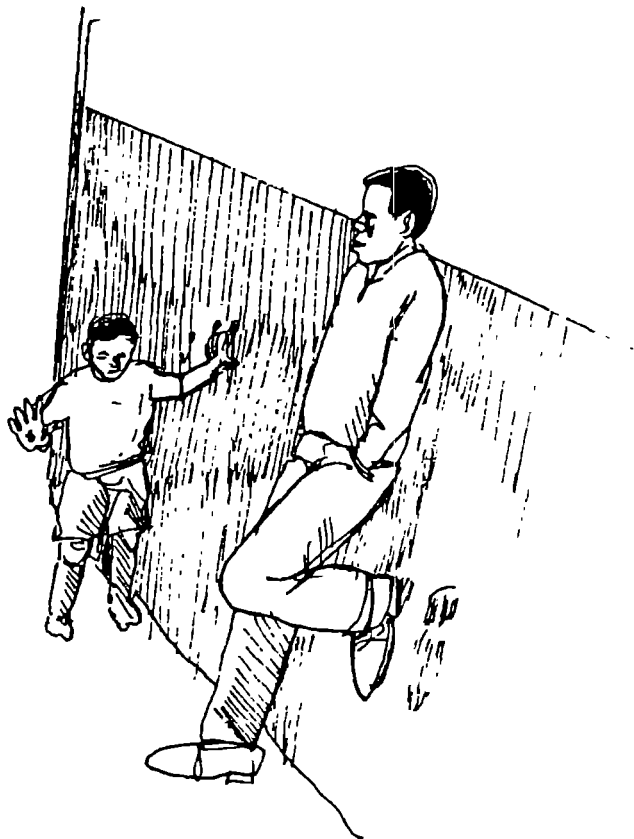

The bottom 1.5 metres of wall, or any wall that is likely to be dirtied such as a kitchen, should be painted with oil based paint. This makes it easy to clean marks off the walls.

Oil based paint should also be used in bathrooms or showers, since it is more waterproof than emulsion paint.

Paint other areas with emulsion paint.

STORING PAINT AND CLEANING BRUSHES

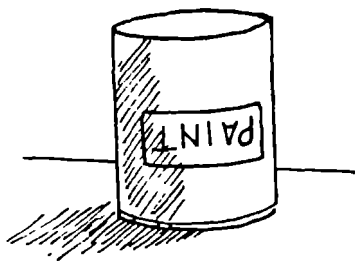

Paint should be stored upside down. Make sure the lid is firmly closed.

The painter must ALWAYS clean the brushes as soon as he has finished using them. He should use thinners or kerosene on brushes that have been in oil based paint and water to clean brushes that have been used with water based paint.

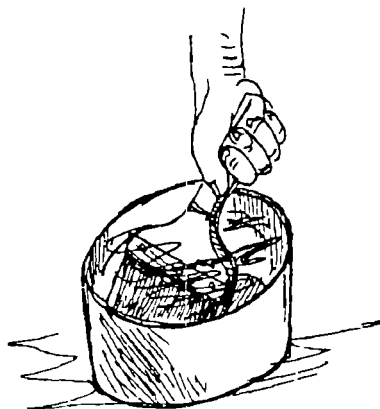

GLASS

MEASURING THE SIZE OF PANES

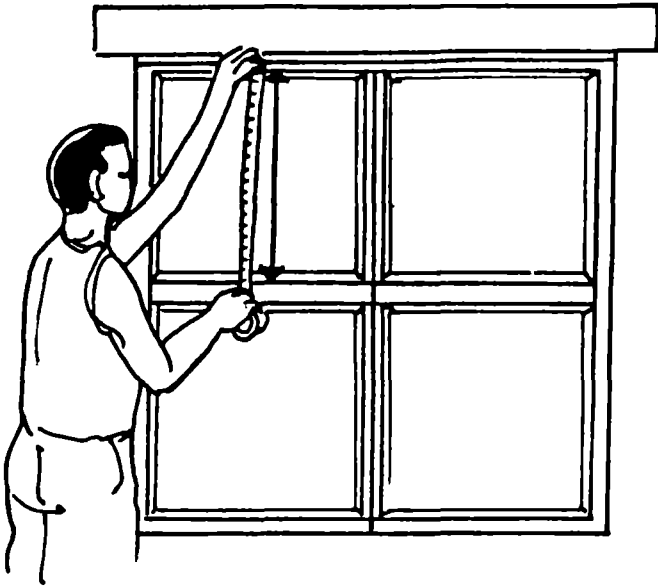

-Measure the size of each window pane in the frame. Make sure you measure right into the corners.

-Take 5 mm off each measurement so the glass is easy to fit. For example if the frame is 220mm x 150mm, you should ask for a pane of glass 215mm x 145mm.

THICKNESS OF GLASS

Thick glass will not break as easily as thin glass, but it costs more. You should choose between 3mm and 4mm thick glass.

Use 3mm thick glass for fixed windows with panes up to 0.4m x 0.5m.

Use 3mm thick glass for opening windows with panes up to 0.35m x 0.4m.

Use 4mm thick glass on all panes larger than this.

Some glass shops will not charge for cutting if you buy the sheets from them. ASK!

HINT: When you are shopping for glass, have all your window pane measurements with you.

PUTTY

When buying putty:

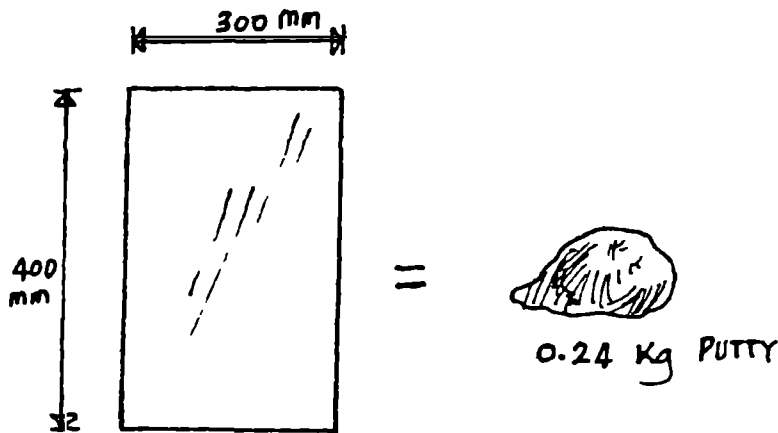

-measure the area of glass in m^2 .

-multiply this number by 2.

-this is the number of kilograms (kg) of putty you need.

DOORS

Hardwood doors will last much longer than flush doors. Always use hardwood doors for:

- external doors,
- internal doors on public buildings,
- where they are cheaper than flush doors.

Buy good quality locks for all external doors

Ensure the carpenters take care when hanging doors. Hinges should line up and the door should be square in the frame, with an even gap.

Wood expands when it is wet, so if the door is a tight fit it may stick in the rains.

The carpenters should only use wood screws - NEVER NAILS - when fixing hinges and locks.

KEY POINTS

- *try not to plaster a newly finished building. Leave it as long as possible.*
- *2 thin coats of plaster are better than 1 thick one*
- *keep plaster damp as it dries*
- *do not add too much thinner to paint*
- *wash all paint brushes immediately after use*
- *take care when measuring glass*
- *hardwood doors will last much longer than flush doors*

Electrical and Plumbing

Fitting electrical and plumbing equipment

Solar power

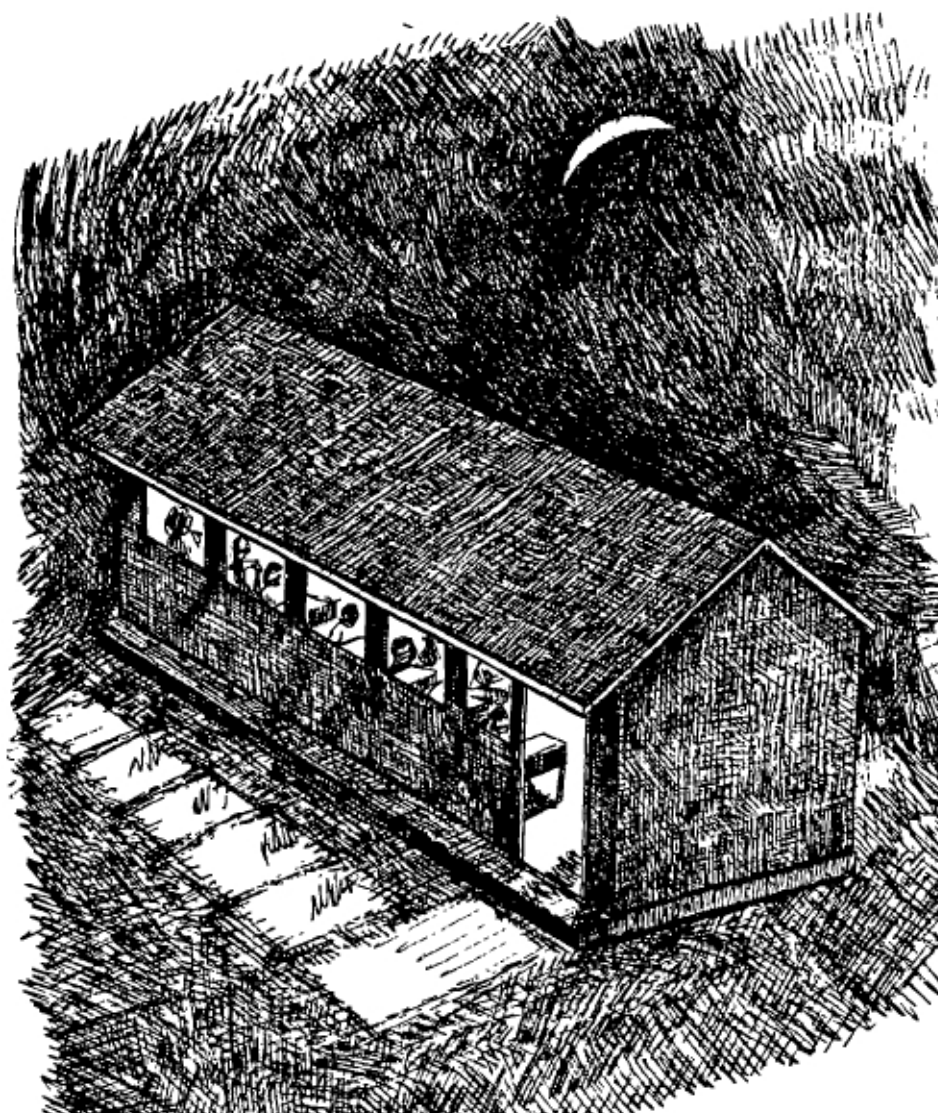

INTRODUCTION

Electrical and plumbing work is very skilled. If your project includes any electrical or plumbing work you must seek expert advice from qualified and experienced people.

SECURITY

Electrical and plumbing fittings are VERY expensive and are very often stolen. Try to make them as secure as possible.

-Fit **STRONG** burglar bars and grill gates to all rooms with electrical or plumbing fittings.

-Use strong, good quality padlocks on all gates, preferably 2 on each. The round "moon" padlock is the strongest. Buy the best you can - buying 2 padlocks will be much cheaper than replacing stolen equipment.

-Locate outside lights in places that are difficult to reach. Make metal covers for them and lock them down.

MAINS ELECTRICITY

Electricity cables run through channels fitted inside the walls, or sometimes under the floor. Boxes are fitted behind light switches and sockets.

Ensure all channels and boxes are put into the wall and the cables are fitted **BEFORE** plastering. This way no work has to be broken.

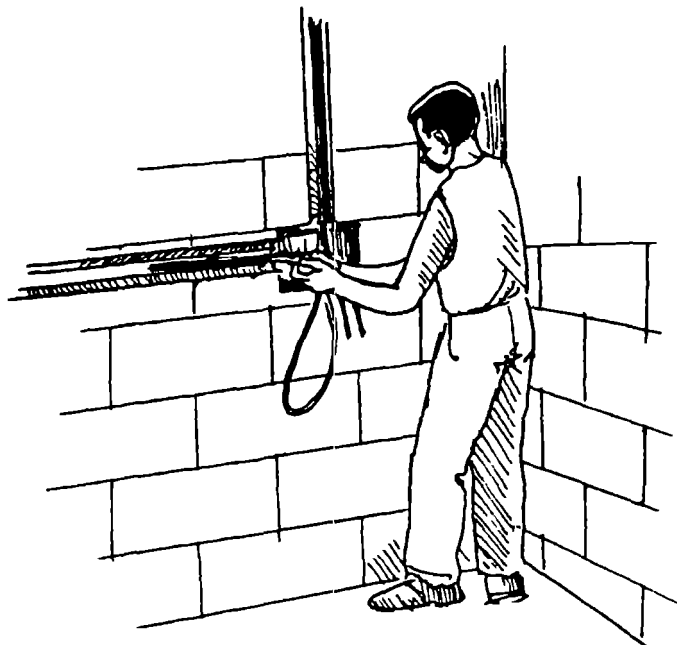

SOLAR POWER

The main parts of a solar power system are shown in the illustration

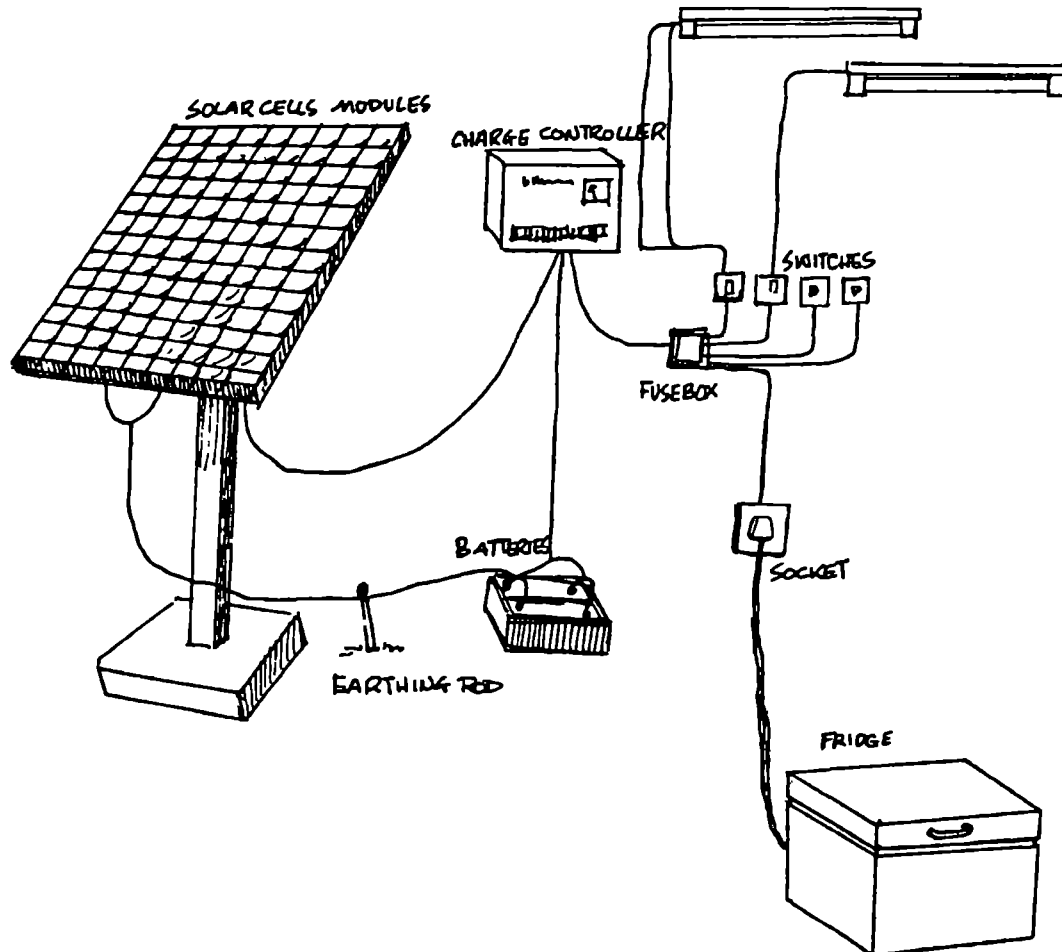

The sun shines on the special sheets called SOLAR PANELS and these convert the power from the sun into electricity

Since the sun does not shine at night, solar systems use special batteries to store the electricity for when it is needed.

The electronic control unit controls the amount of electricity between the solar panels and the batteries.

The solar system should be installed by the company it is bought from and they should give you all the instructions you need to operate and maintain it.

Make sure you understand these instructions and follow them carefully. If you don't the system will soon break down.

The solar panels are the most important part of the system. Discuss the best place for them with the people installing them. Obviously they must be in a sunny place, but they must also be somewhere where they cannot be damaged.

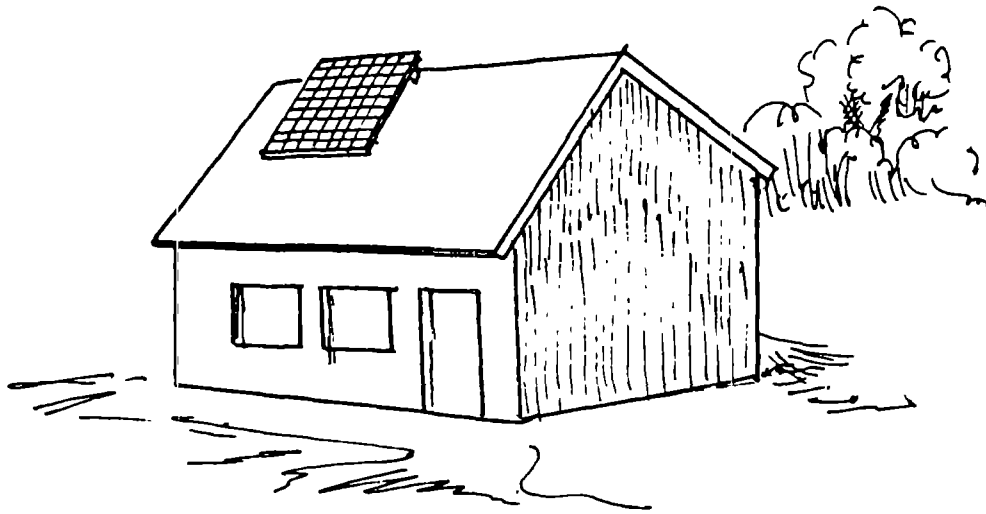

IMPORTANT

Solar panels are very easily broken. Be especially careful with children. They **MUST NOT** touch or throw stones at the panels. If you catch anyone doing this, punish them immediately and publicly as a warning to others.

You should also try to secure the panels and the batteries to make them difficult to steal. They are very expensive.

MAINTENANCE OF SOLAR SYSTEMS

Solar systems require very little maintenance:

- wipe the panels clean every 2-3 months,
- clean and secure all electrical connections every 6 months,
- check the levels in the batteries every week. If it is a sealed battery, check every 6 months. Top them up when necessary.

Look after the system properly and it will last many years.

PLUMBING

If you are installing plumbing, find out AT THE START where pipes will go and try to leave holes for them. It is better than breaking holes later

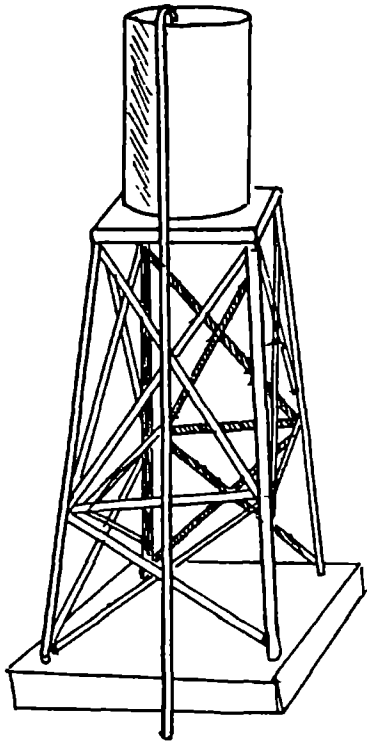

If you are putting in a water tank, make sure the supports are strong. If it is going in the roof of a building, reinforce the roof and locate the tank over a supporting wall. If it is an outside tank, make sure the tower is strong. Build it on a strong base, like the foundation and floor slab of a house.

Make sure all plans are approved by MPU. Follow them closely.

Educate users to take care of things like ablution blocks
Toilets and basins are easily damaged Keep everything clean.

For public use, buy taps which are operated by pressing a button on the top Push button taps are much stronger than normal ones and cannot be left running to waste water

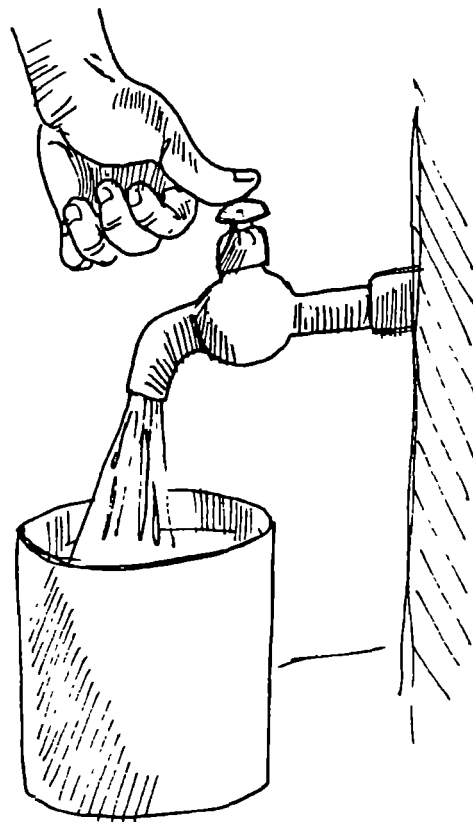

Whether you are connecting your system to a main sewage line or installing a septic tank, have all your plans approved by both the Council and MPU in writing

KEY POINTS

- *use experienced and qualified people for all electrical and plumbing work*
- *make sure all electrical and plumbing equipment is secured*
- *plan ahead, to avoid breaking finished surfaces*
- *follow all operating and maintenance instructions for solar equipment*

Drainage

Types of drains

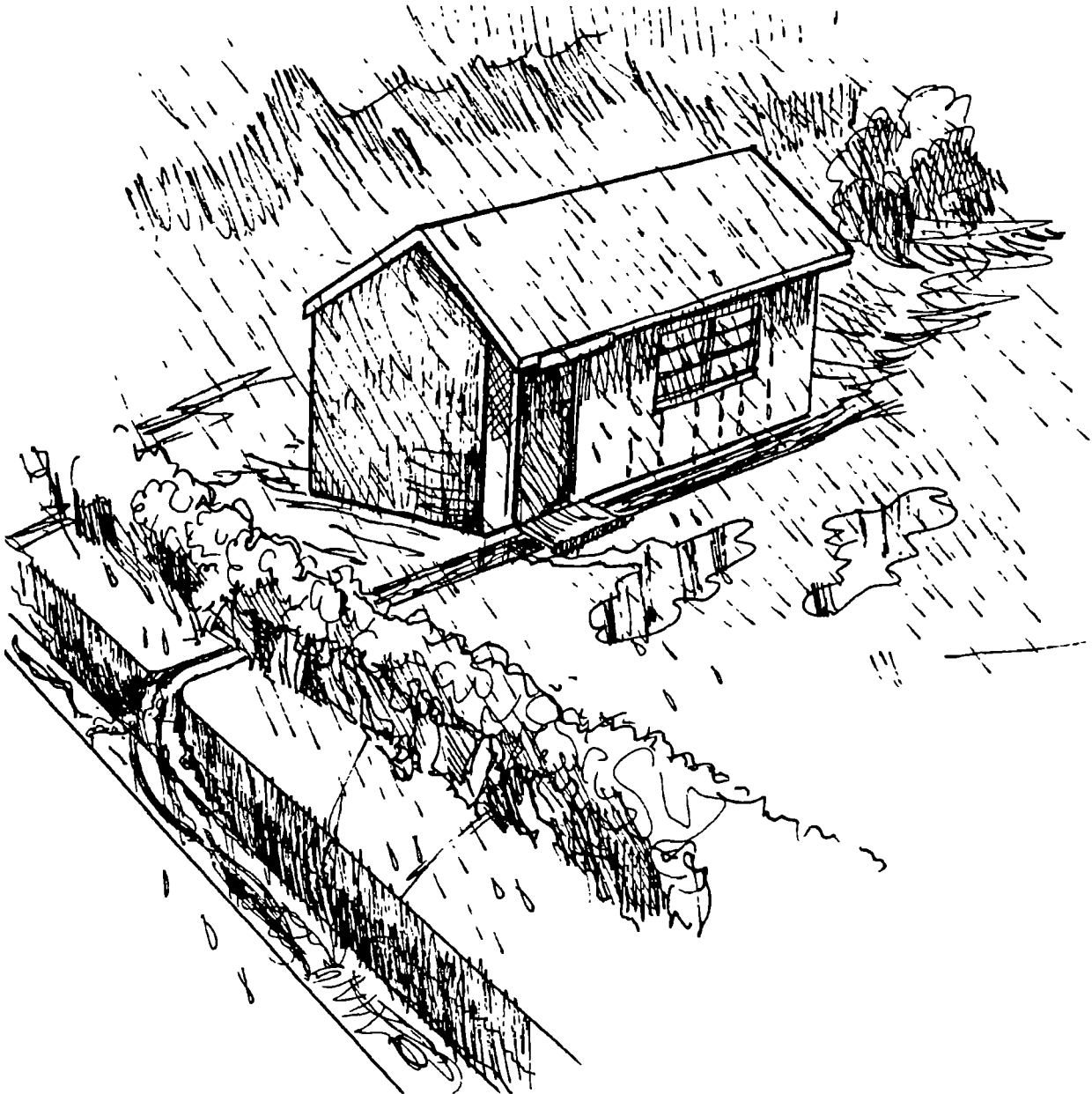

THE IMPORTANCE OF PROPER DRAINAGE

Water is a danger to your building. If you do not have good drainage, heavy rains can wash away the foundation.

Put in good drainage to channel water away from your building.

There are 2 main types of drain:

1) 3 BRICK DISH DRAIN

This can be made from 3 bricks laid on a hardcore or laterite base. Dry mortar mix should be brushed into the joints to make it more waterproof.

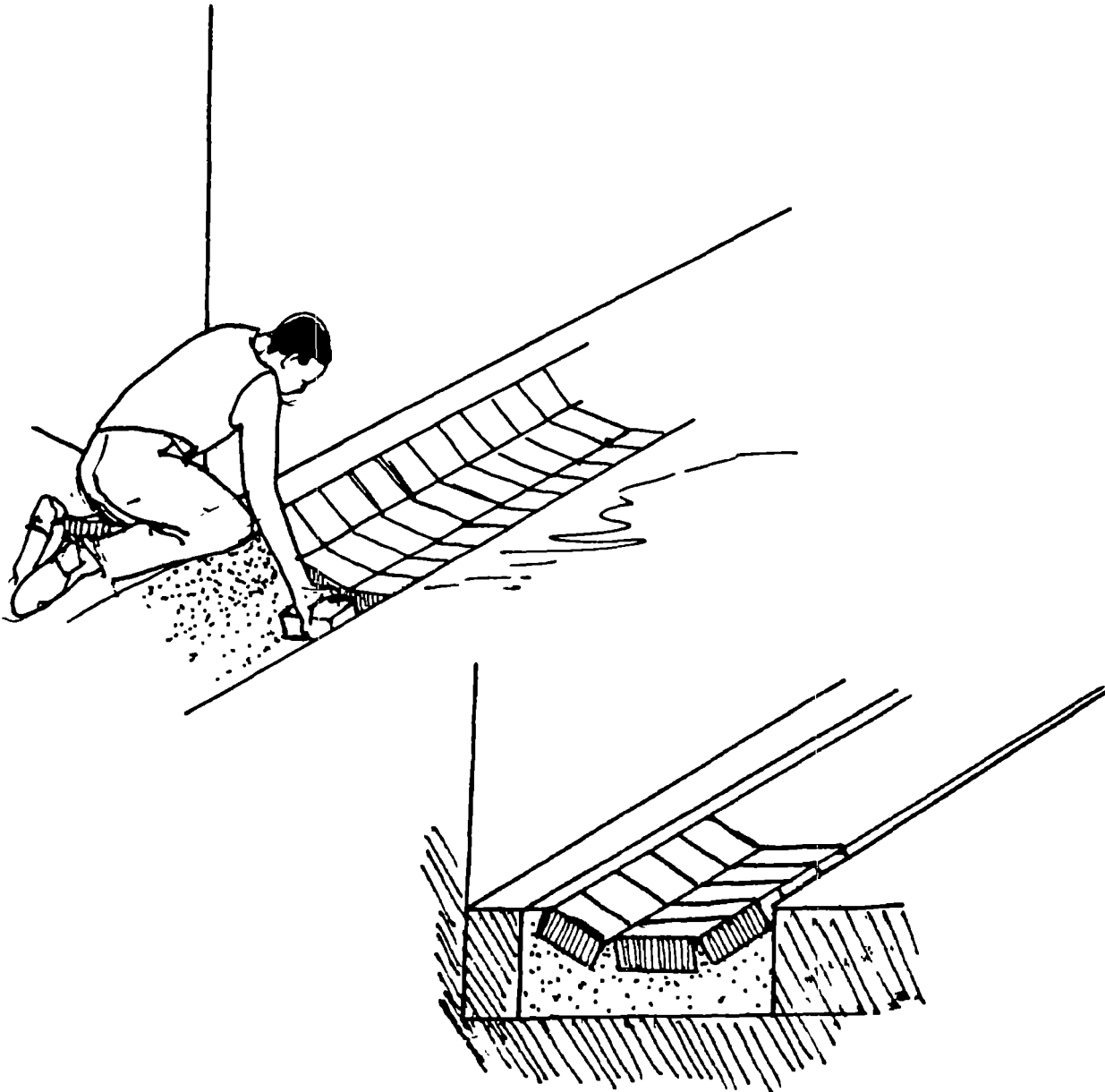

2) CONCRETE DRAIN

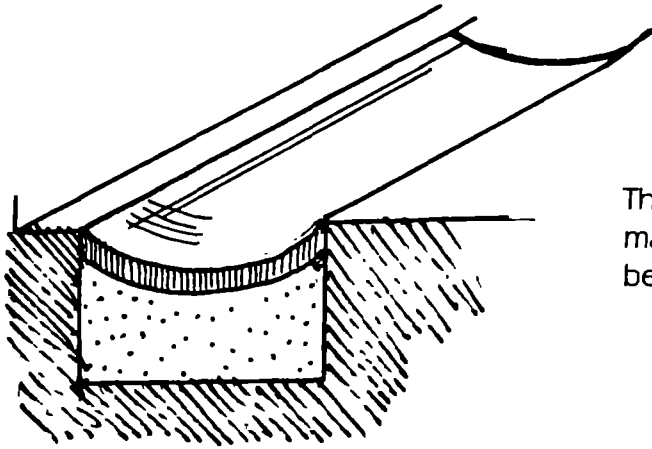

This is like the 3 brick dish drain, but made from concrete which means it will be more expensive.

The supervisor should ensure there is a small slope along the drains, so the water flows down them.

Make sure the drains take the water well away from your building, wherever possible into natural ditches or water courses.

Do not allow your drainage to create pools of water, which can be unhygienic.

KEY POINTS

- put good drains around all your buildings
- do not allow water to collect in pools

Rehabilitation

Reasons for rehabilitation

How to carry out rehabilitation

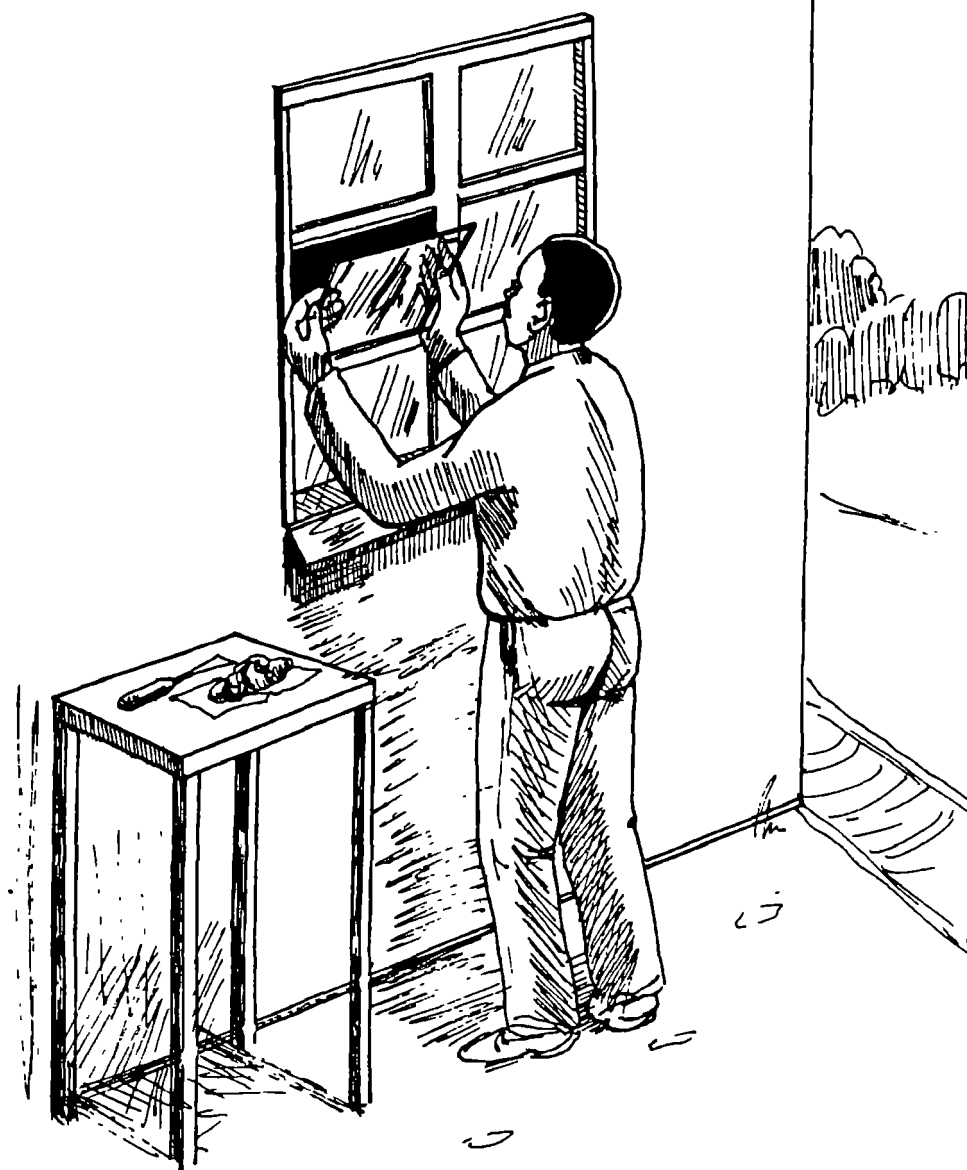

REASONS FOR REHABILITATION

Rehabilitation means restoring or repairing something. If it is done right, a rehabilitated building will be as good, or sometimes even better, than a new one.

There are 3 main reasons to rehabilitate something

Accidental Damage:

fire, flood, wind, vandals, etc

Poor Construction:

weak foundations, roofing timbers too thin, steel omitted from the lintels, not enough cement in concrete and mortar mixes, etc

Lack of Maintenance:

doors rot due to lack of painting, roofing sheets broken or blown off because nails were loose, walls collapse because water erodes the foundations, roof collapses because of termites eating rafters, sewers burst because blockages not removed, etc

Many buildings can be rehabilitated but sometimes it is not worthwhile. The decision must be made by an expert.

HOW TO CARRY OUT THE REHABILITATION

The techniques involved are basically the same as those required for general construction. A good rule to follow is:

"if you are not sure, replace it!"

IMPORTANT

First make sure any work you are going to carry out is included in your MPU budget.

There are 3 things that apply to all rehabilitation work:

- Make sure all structures are well treated with termite poison.
- All loose, broken, rotten masonry and wood should be cut out and replaced.
- DO NOT paint the building until ALL work is completed and AFTER a thorough inspection.

STRUCTURAL REHABILITATION

Foundations:

- Seek expert advice for any work involving the foundations.
- It will probably mean digging out very deep and making a reinforced concrete support for the old foundations.

Floor Slab:

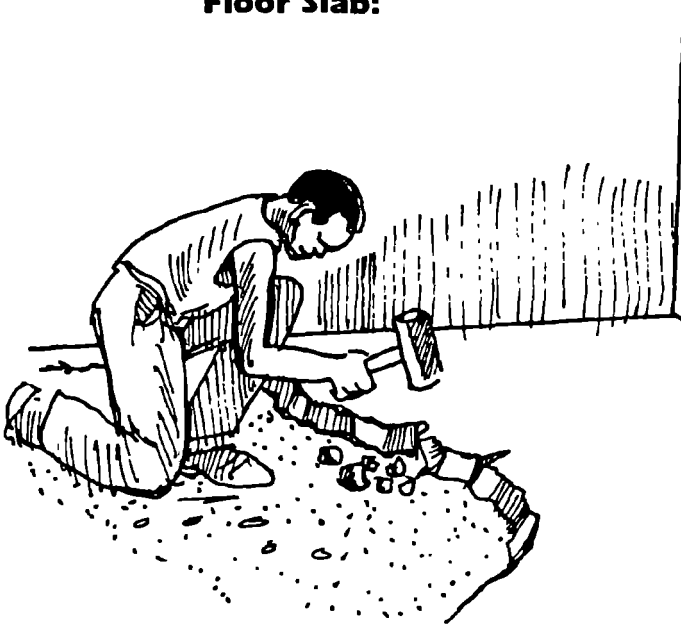

-Major repairs would mean breaking up the old floor and compacting the hardcore or laterite fill (adding more to level it if necessary).

-The new slab is then relaid. The new slab **MUST** be reinforced with conforce (BRC reinforcing mat).

Floor Screed:

- If the screed is very badly damaged replace it all. Check the slab carefully at the same time.
- Minor cracks and hollows can be repaired using "PYA plaster" (see below).

Walls:

- Cracks in walls may mean the foundation is weak. Seek expert advice before starting any work.
- Major repairs means the wall has to be taken down and rebuilt from foundation level. Put brickforce between courses after every 600mm.

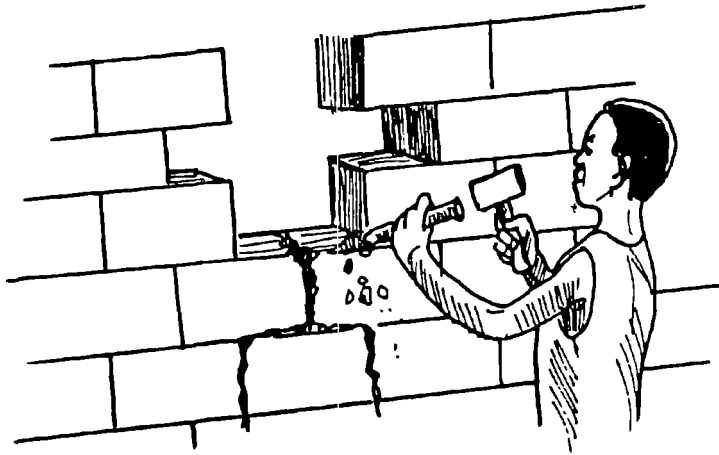

-Smaller cracks can be repaired by removing 2 or 3 bricks on each side of the crack and rebuilding.

-Severely cracked plaster can be hacked off and replaced with fresh plaster strengthened with chicken wire

-Small cracks can be repaired by raking out all loose material and then filling with "PVA plaster"

IMPORTANT

Use strong bricks or blocks for repairs, or the problem is likely to recur

Doors and Windows:

-Replace all exterior flush doors with solid hardwood doors.

-Keep any flush doors which are in good condition or repairable and use them inside other buildings.

-After the carpenter fits the doors, remove them and paint the bottoms for protection.

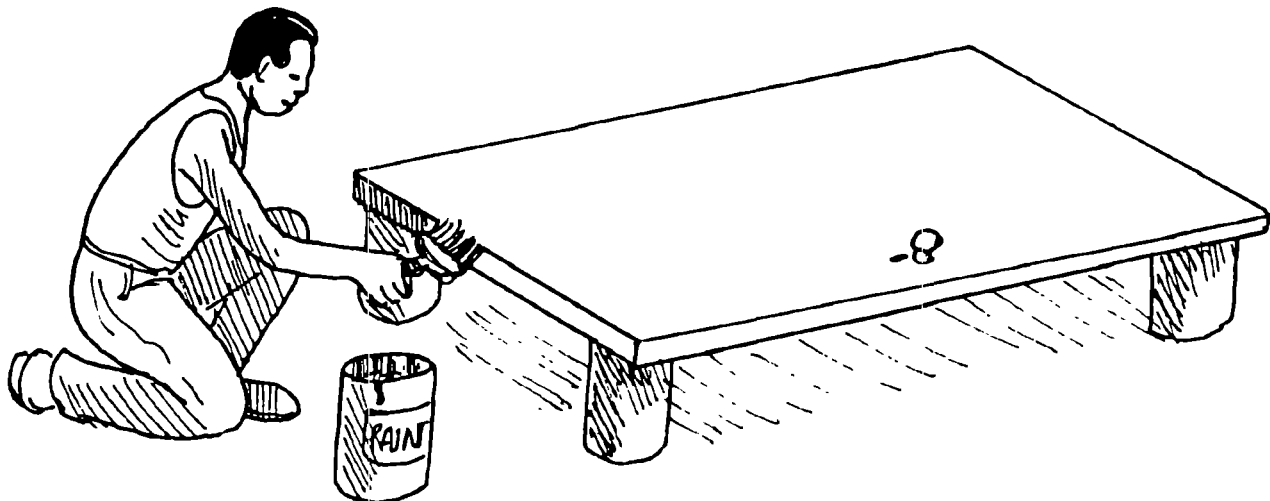

-If you have old mortice locks, try to keep them and get keys if necessary.

-Where theft is a problem, consider fitting exterior doors so that they open outwards. This makes them more difficult to break open.

-If necessary, weld burglar bars to window frames BEFORE fitting glass. Also clean the frames and apply a priming coat of paint.

Ceilings:

The best method is to:

-strip the ceiling,

-cut off the damaged edges of the good boards, making all the boards the same size

-re-erect the bracing to fit the new, smaller size of ceiling boards.

-If only a few boards are sound, replace the lot: bracing, boards and cover strips.

Sometimes it is possible to make tidy repairs simply by fitting new wider coverstrips.

Roof:

-Take care in removing any good roof sheets.

-If the roof is badly damaged it is better to remove it all and remake the trusses.

-Check the condition of the wall plate. It is advisable to replace it while the roof has been removed.

-Spend a bit of time planning so that you make the best use of what sound materials you have. For example, if you have only a few good roof sheets it may be better to replace them all and use the few good ones on pit latrines.

REHABILITATION OF SERVICES

Water:

- Check all pipes for corrosion and build-up of scale. Unscrew them and unblock them with long rods if necessary.
- All tap seats should be recut and new washers fitted
- Make the system better if possible, such as by fitting self-closing taps.

Electricity:

- Make sure your electrician "earths" all the work.
- A ZESCO inspector must test EVERYTHING before it is used.

Sewerage:

This is another area for specialist advice

- Pipes should only be laid in straight lines.
- There must be inspection chambers at EVERY change in direction.
- Septic tanks must have cross-walls to ensure they work properly.

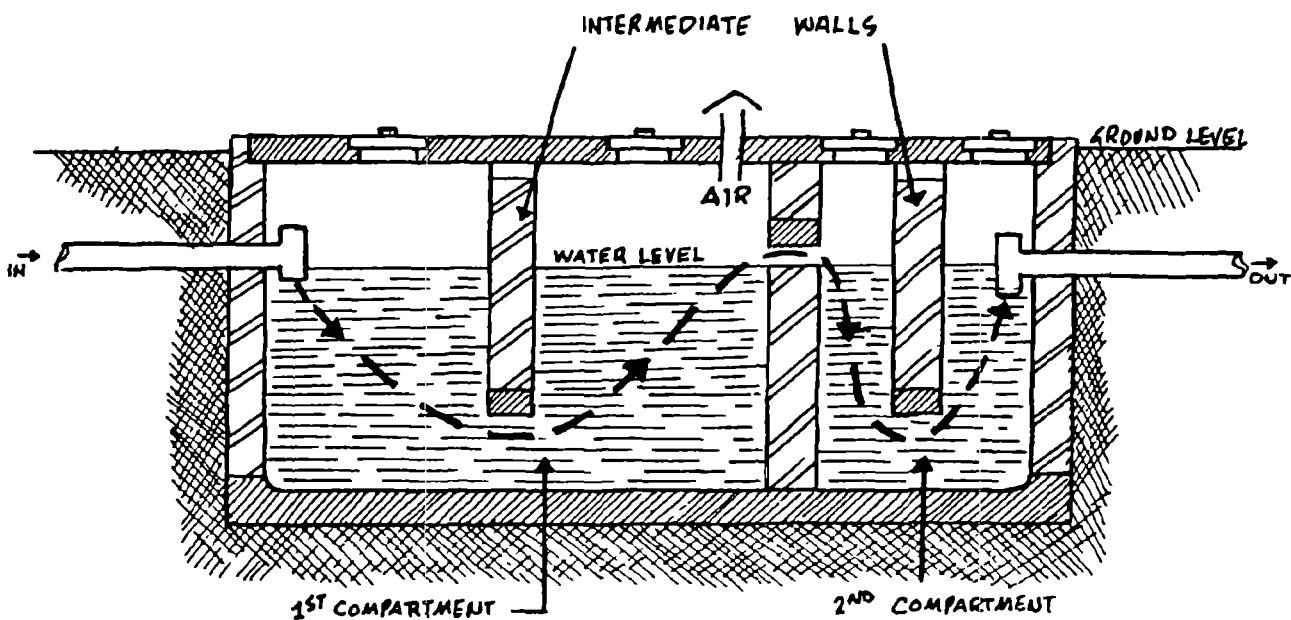

Drainage:

- Water must be channelled away from buildings
- Ditches or channels should be dug to stop water running downhill towards your building.
- Drains should be put around all buildings to stop water from the roof eroding the soil at the base of the walls.

Access:

- The road to your project is the first thing visitors will experience. Try to make it accessible all year.
- Any road is ONLY as good as its drainage, so make sure water does not lie on its surface.
- Ensure that any culverts are kept clear.
- Slash the vegetation at the sides of the road, but do not remove it completely as it protects the soil from erosion.

Environment

- It is YOUR project, so make it attractive by planting flowers and trees as you would at your own house.
- Do not plant flowerbeds close to the walls of buildings where this could interfere with any drains.

USEFUL TIPS**Cement "PVA Plaster"**

- To repair thin and shallow holes as in screeds, window cills etc. make a paste the consistency of toothpaste using sand:cement (1:1) and PVA glue:water (1:1).
- Clean the area to be repaired of all loose material and "paint" it with a little of the glue/water mixture.

-After 5 minutes firmly press the mixture into the gap and smooth the surface.

IMPORTANT

The paste should be used within 30 minutes

“Tarred Cement”

-To make minor repairs on a roof sheet mix cement and tar together. The tar is sometimes called “Colas”. Ask the Roads Department for this.

-Use the cement:tar mix to repair small holes and cracks.

-If the hole is more than 4mm wide, cover the hole with a piece of strong paper or cement bag to support the mixture until it sets.

“Strong Whitewash”

-To make whitewash last longer and to make it more water resistant, add one part cement to each nine parts of lime.

KEY POINTS

- a properly rehabilitated building can be as good, or even better, than a new one
- all rehabilitation needs to be assessed by a specialist to decide if it is worth doing
- only use good materials in rehabilitation, or problems will only recur.

Wells

Choosing a site

Digging the well

Using the well



INTRODUCTION

There are 2 types of well - dug wells and boreholes. Which type you use depends on your situation.

Dug Wells - used where the water is less than 24 metres below the ground. They are cheap to install, easy to maintain and can be dug by the community. Water is usually drawn by bucket, chain and windlass.

Boreholes - used where water is much further below ground and hand pumps are used to draw water. Boreholes have to be sunk with specialist equipment. They are much more expensive to install and maintain.

All wells **MUST** have a Well Committee to organise maintenance.

This book will only discuss how to construct a dug well. If you are putting in a borehole it will be done by specialists.

SITING

The water in the well must not be polluted.

Ideally the well should be at least 100m away from any pit latrines, if space allows.

Try to site the well uphill of any latrines, so there is even less chance of pollution.

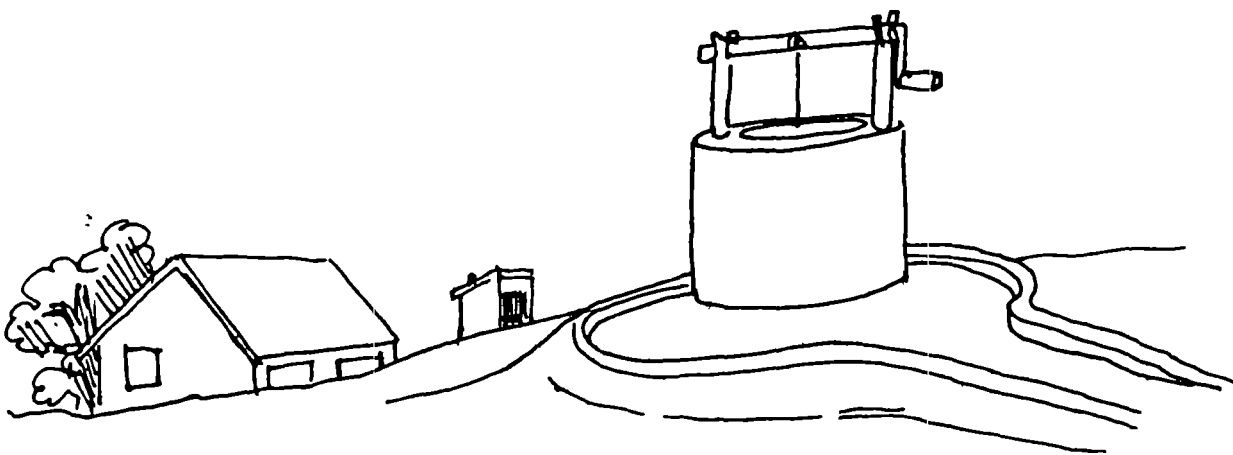

DIGGING THE WELL

The main community contribution will come from digging the well. Follow these rules

-The best time to dig the well is towards the end of the dry season, when the water should be at its lowest possible level.

-The well should be dug at least 200mm larger in diameter than the concrete rings you will be using.

-NEVER allow one man to dig alone. There must always be someone at the top of the well in case of problems. They must agree a system of signals so the digger and the man at the top always know what the other requires.

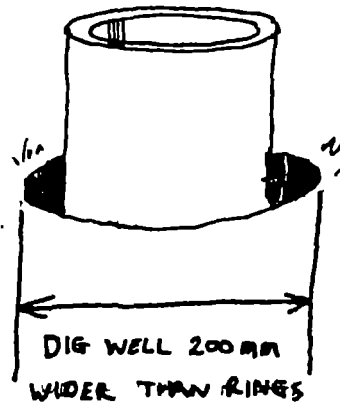

The top of the pit must be secure. Timber shuttering must be made if the soil is loose or sandy.

-Make sure that the ropes and supports used to lift the soil are strong and secure.

-Ensure the soil is taken at least 4 metres away from the top of the well to prevent accidents.

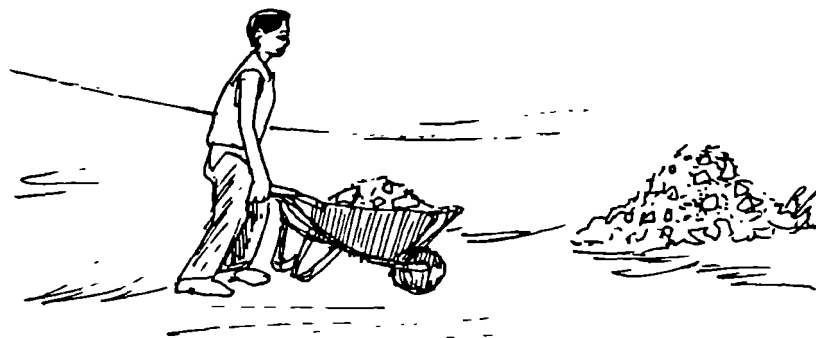

-Make sure the well is dug exactly vertical. Check it frequently.

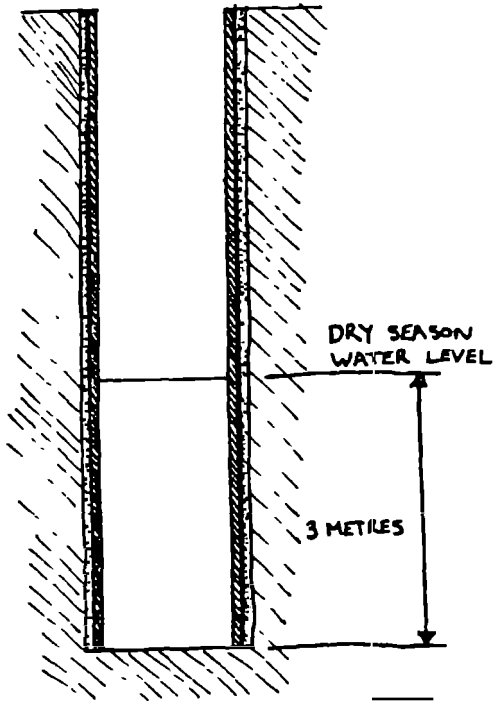

-Ideally the well should be dug at least 3 metres deeper than the dry season water level in order to provide enough water for a community.

-The bottom of the well should have a 100mm layer of gravel on top of a 100mm layer of sand. This filters the water coming into the well.

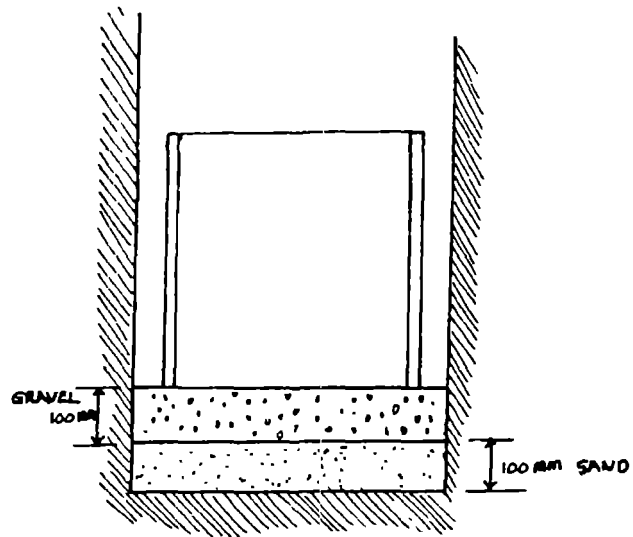

- If a lot of water comes in while you are digging, try to borrow a pump from the Department of Water Affairs, an NGO or some other local organisation.

RING MOULDS

You may be able to buy the rings already made. Ask at the Department of Water Affairs. However if you have to make the rings yourselves, hire the ring moulds and follow these steps

-the rings in the top 3 metres of the well **must not** allow water to get in. This prevents pollution of the well. A 1:2:4 concrete mix for these rings will make the concrete watertight.

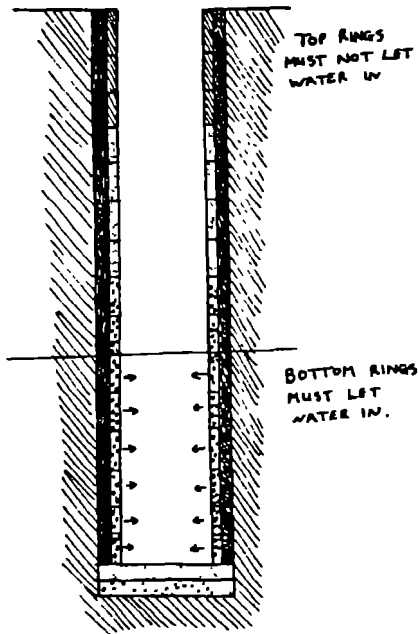

-water should be able to get through the lower rings. A concrete mix of 1 part cement to 8 parts stone for these rings (no sand) ensures they will allow in water.

7-the concrete should be poured and compacted in layers.

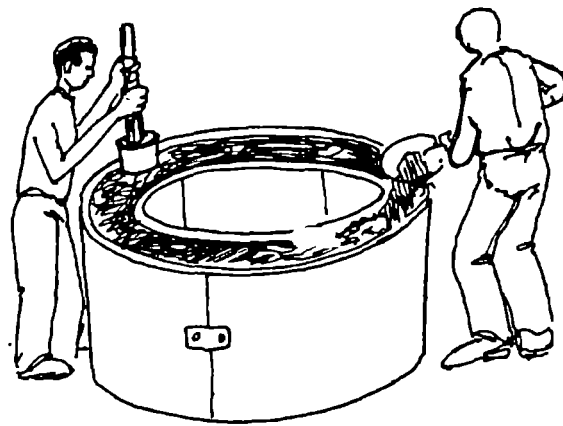

-leave the concrete in the mould for at least 24 hours

-the top ring and inner section can then be removed, but do not remove the bottom ring and outer section. This will support the ring.

-leave for another 24 hours

-now the rest of the mould can be removed.

-leave the ring to cure for at least another 5 days. Keep the concrete damp during this time.

-clean the mould sections thoroughly before casting another ring.

-the rings can be reinforced by adding metal rods. These are not needed once the rings are in the well, but it makes them stronger for transporting and installing them. 10mm diameter vertical bars every 200mm around the ring provides sufficient strength.

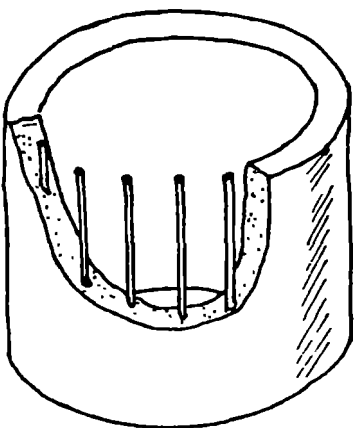

TRANSPORTING RINGS

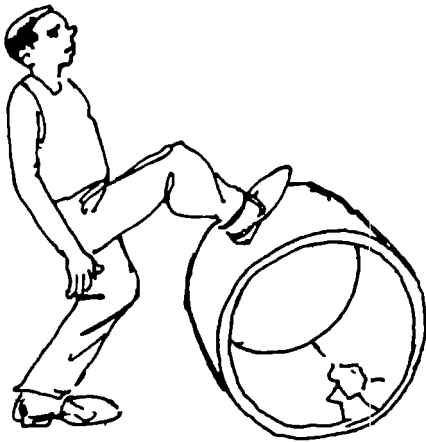

-never roll rings along the ground. They will break.

-always lift and carry rings from place to place.

-if you have to transport rings by vehicle, place them upright on wooden supports and tie them down well.

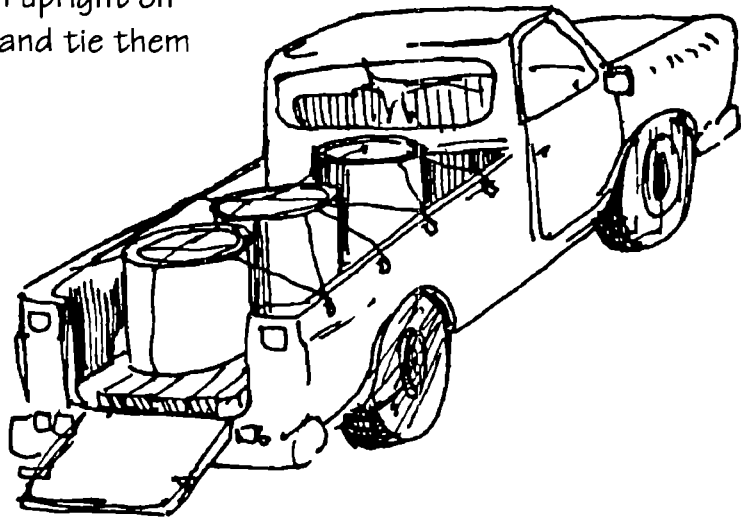

INSTALLING RINGS

-a tripod and pulley system is required to install rings in the well.

-make sure the lifting system is strong enough.

-each ring should fit neatly into the next.

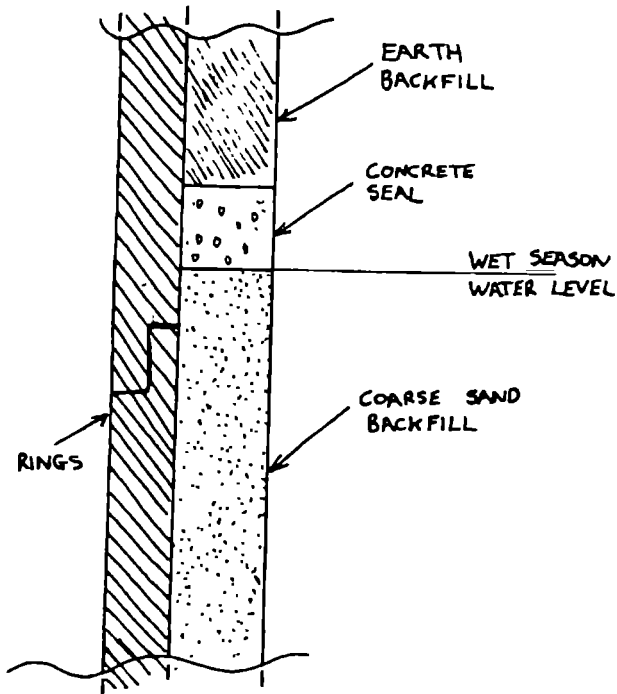

DETAILS OF BACKFILL

The best and safest method of installing rings is for the first ring to be lowered into the well and the labourer digs beneath it. The ring drops as the earth is removed. The next ring is added and the process repeated. This method stops the sides collapsing as the well is dug - an event that is common and causes serious injury

-backfill around each ring. The rings below wet season (March) water level should be backfilled with coarse sand. A layer of concrete should be poured on top of this to prevent polluted surface water getting into the well. The remainder is backfilled with earth.

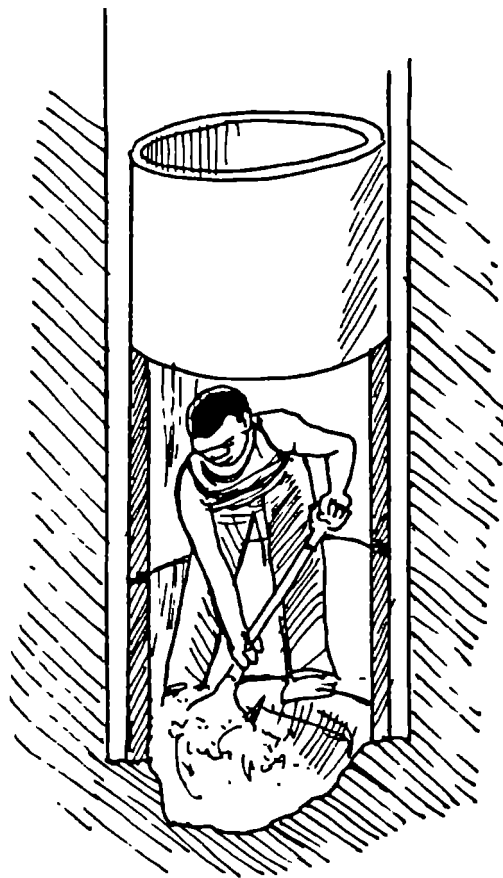

IMPORTANT

NEVER dig more than 5 metres without installing either more rings or timber shuttering to prevent collapse

DRAINAGE

The top of the well must be clean, safe and protected from surface water.

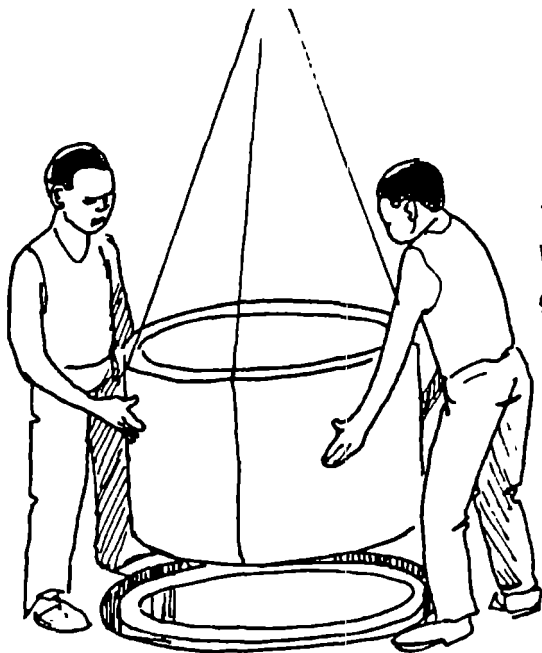

-either build a wall around the top of the well, or add an extra concrete ring above ground level. Plaster the wall.

-cast a reinforced concrete top to cover the well. This should be about 125mm thick.

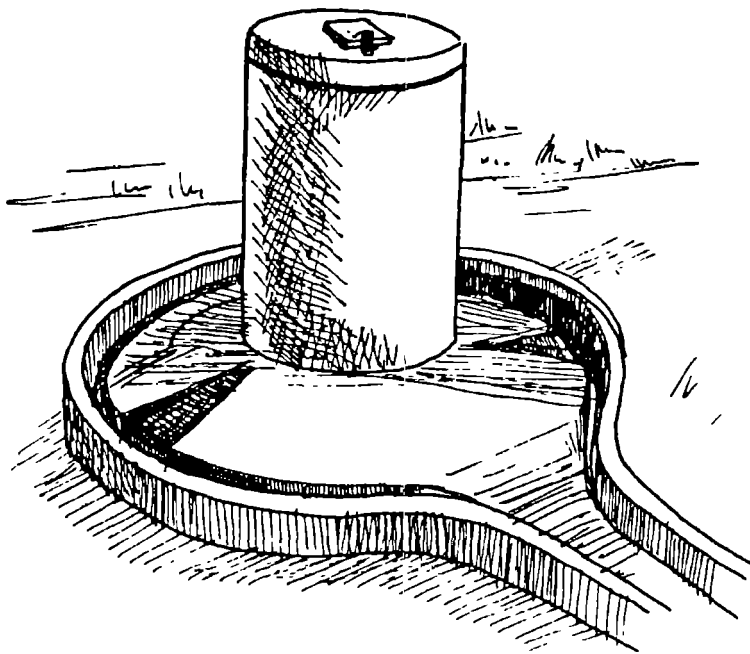
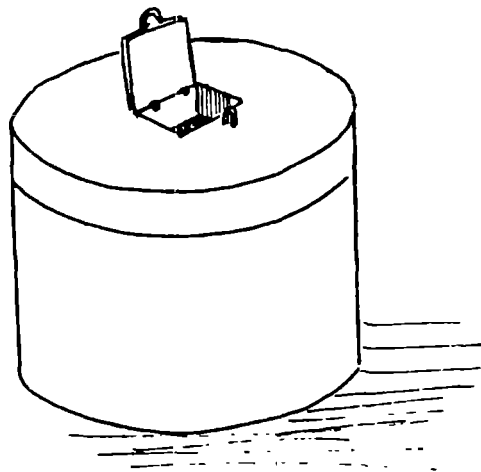

-lay a 75mm thick concrete slab for 2 metres around the well. This is called the APRON. It should be at a slope with a drain around the sides to carry spilled water away. The apron should be built on a well compacted hardcore base.

-have a lid over the well to stop anything falling in. Make sure the lid is kept locked and only opened by a member of the well committee.

-make a good drain leading at least 15 metres away from the well.

-dig a large, deep pit at the end of the drain and fill it with rubble. This is called a SOAKAWAY and allows water that is spilt to drain away gradually.

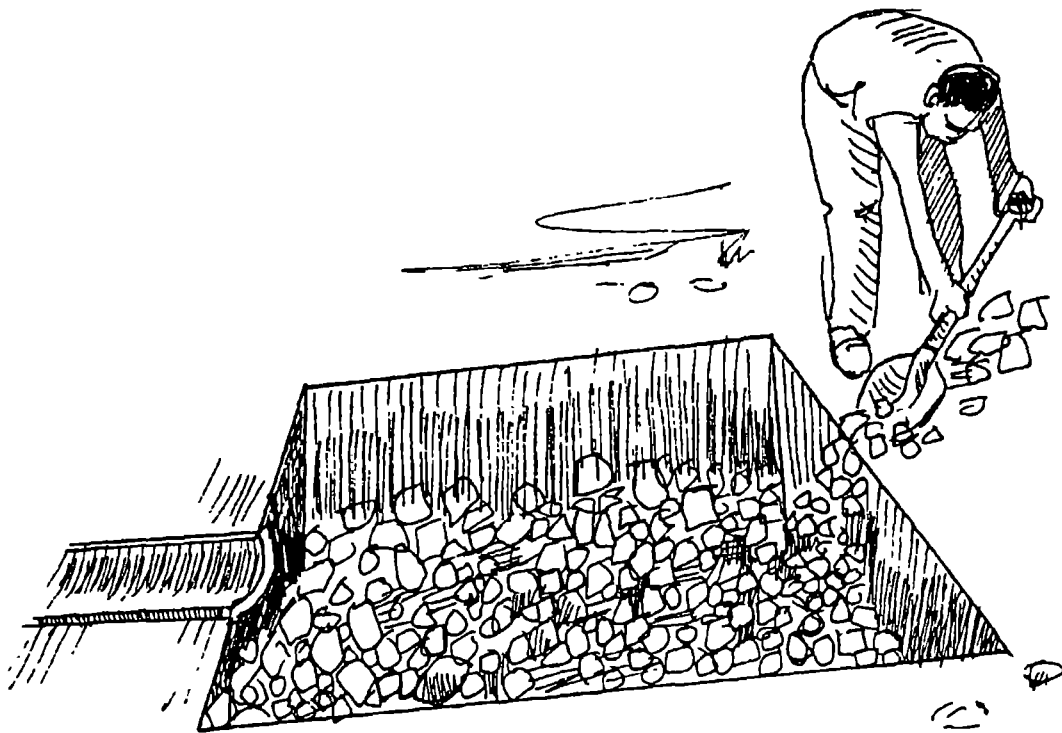

CLEANING THE WELL

The first water that is taken from a dug well will be too dirty to drink. The well must be cleaned before it is used. The best way to do this is to empty the well 3 times before drinking any of the water.

If the well fills up quickly this may not be possible using buckets. Perhaps you can borrow a pump.

There are also chemicals that you can put into the well to make the water safe to drink. Talk to the Department of Water Affairs about these.

EDUCATION

Do not let your well become polluted

- Do not let people throw anything in the well
- Do not wash clothes or children near the well.
- Do not let people use their own buckets to draw water from the well.
- The Well Committee must organise “Education Days” and talks by Public Health officials to educate the community about proper use of the well.

KEY POINTS

- make sure wells are protected from all sources of pollution
- ensure you have a well committee
- ensure all digging work is carried out SAFELY
- make sure you build a good well apron, drain and soakaway
- have a lid on the well and keep it locked when not in use
- educate the community to use the well properly

Roads

Parts of a road

Mitre drains

Culverts

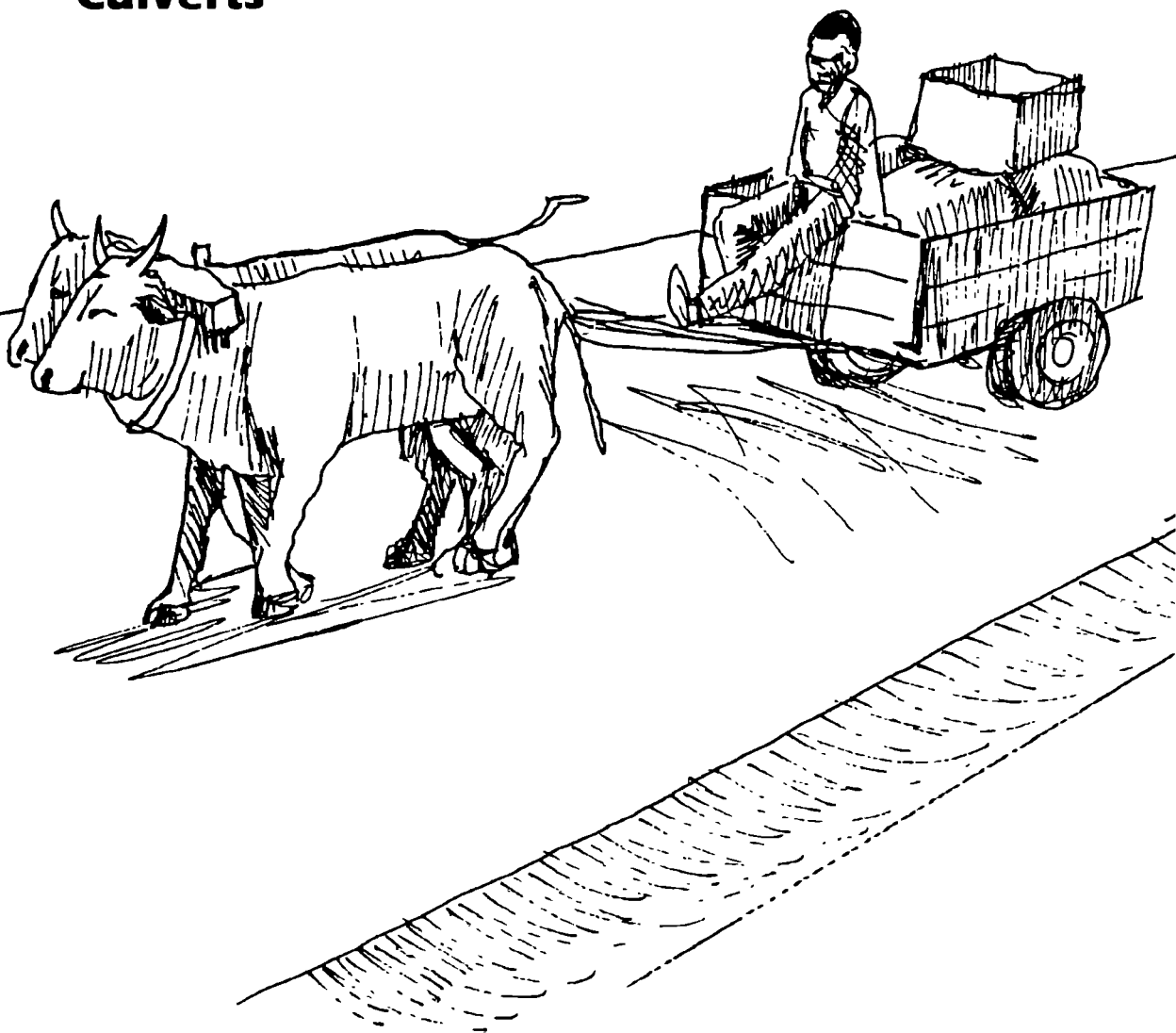

INTRODUCTION

Constructing roads and culverts is a very skilled job. They can only be covered in brief detail in this book.

You must seek specialised help if your project involves construction or rehabilitation of a road.

ROADS

MPU use a standard design for roads. Your Regional Officer will discuss it with you if necessary.

A section through the road should look like the sketch.

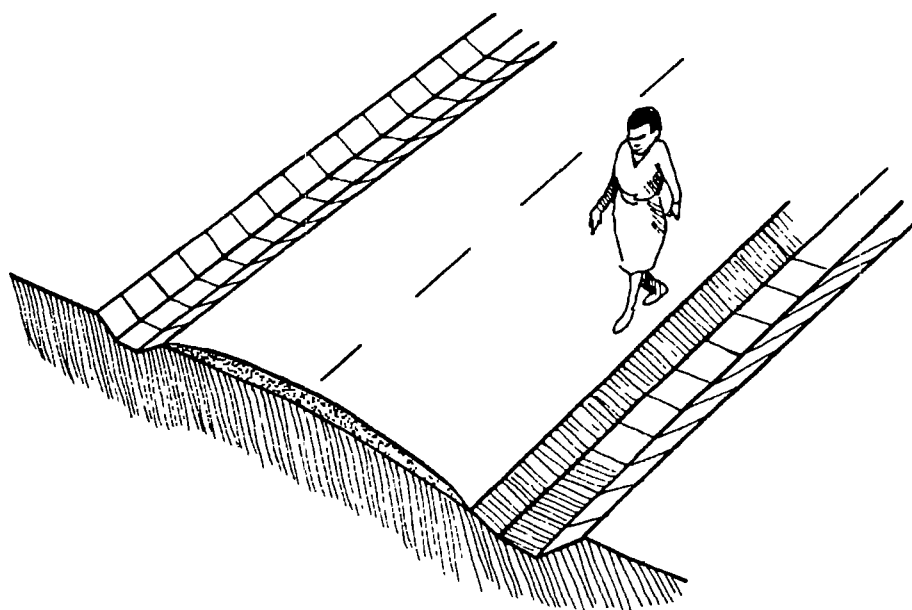

The important points to notice are:

- (1) The road is not flat. It is shaped so that water can run off the road from the centre to the sides.
- (2) There must be a drainage ditch on each side of the road.
- (3) There is a laterite covering over the section of the road where vehicles drive. This laterite is normally about 150mm thick, but may be thicker if heavy vehicles use the road or the base of the road is not very strong.

All tall vegetation should be cleared back for 5 metres on each side of the road.

MITRE DRAINS

MITRE DRAINS take water away from the side ditches.

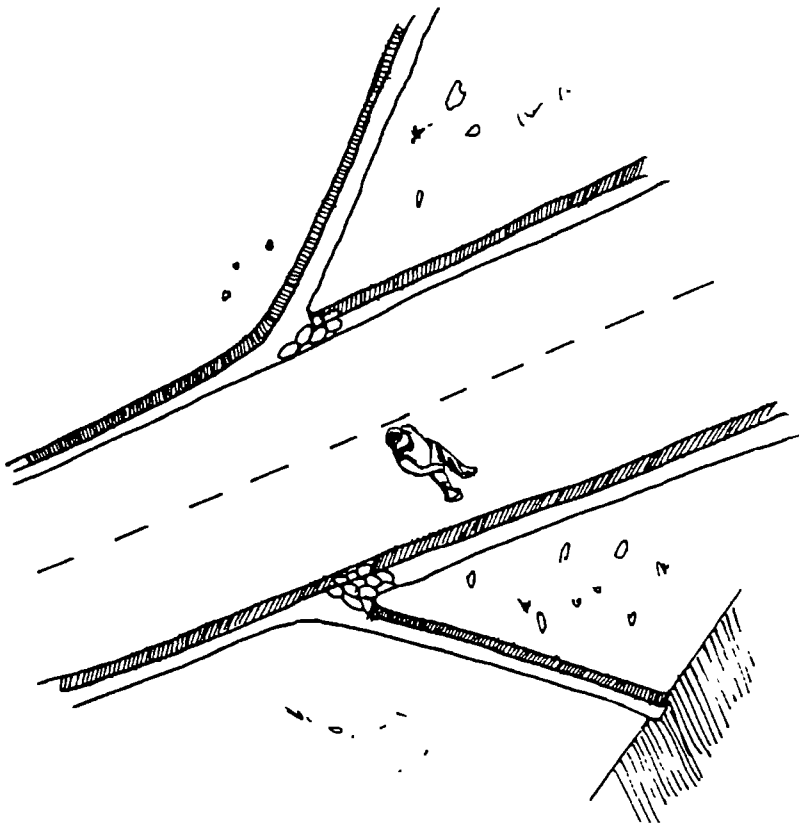

Each mitre drain should be 1 metre wide. The distance between them depends on the slope of the road. The steeper the road, the more frequent the drains. The frequency must be decided by a qualified engineer.

The mitre drains turn off the side ditches at an angle of 30 degrees. The mitre drains should slope gently down, away from the road.

All tall vegetation should be cleared 2 metres on each side of the mitre drain.

CULVERTS

Where roads pass over streams, wet land or anywhere water is likely to flow, concrete pipes must be put under the road for the water to pass through. These pipes are called culverts.

Common pipe sizes are 600mm, 900mm and 1200mm in diameter. They should be laid carefully as in the illustration.

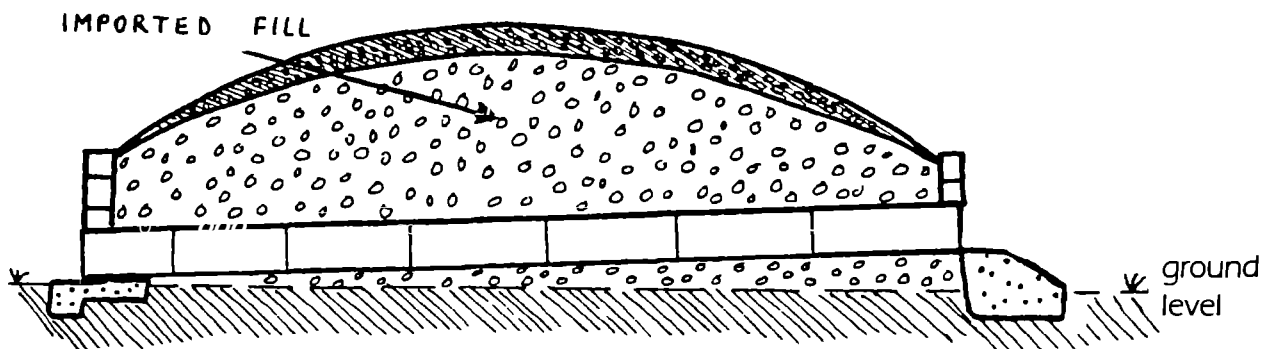

Notice that:

- the pipes must slope gently downward in the direction of the water flow,
- the pipes are surrounded by well compacted backfill. They can also be set in concrete to give them more strength.
- there is a headwall to prevent water getting round the outside of the pipes,
- concrete skirts and aprons prevent erosion at both ends of the pipe.

KEY POINTS

- a road is only as good as its drainage,
- regular maintenance is vital, especially immediately after construction,
- water must not be allowed to lie on the road for any length of time,
- small holes and hollows must be filled quickly.

A - Z of Useful Tips

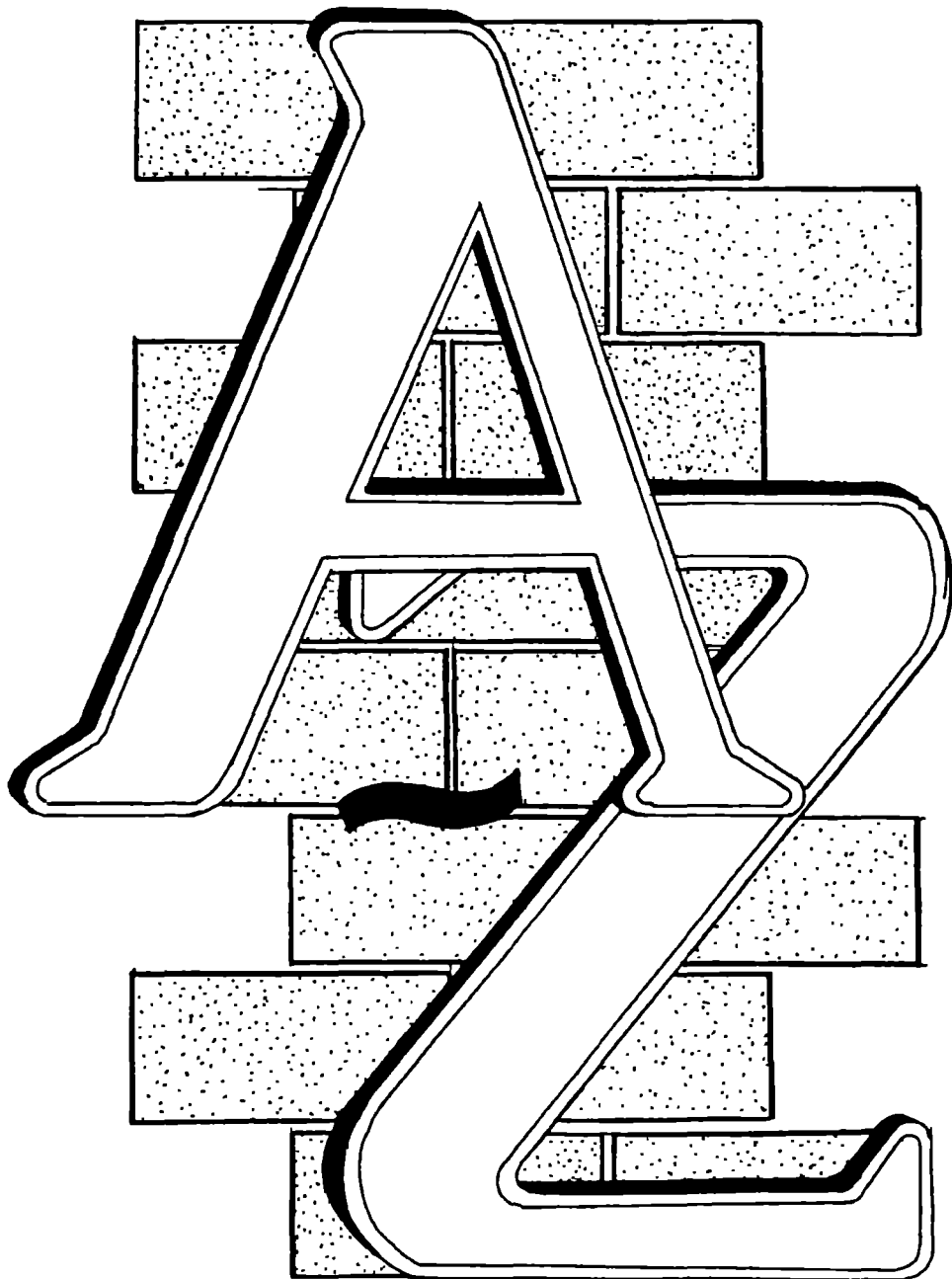

A - Z OF USEFUL TIPS

Asbestos/Cement

is the correct name for "asbestos" roofing sheets, pipes etc

It is made in Zambia

It will last long provided it is treated carefully.

The best way is to saw it with a special saw

But most carpenters make a line of small holes using a small sharp cold chisel. Then they "snap" it to break along the line of holes

CAUTION - the dust from asbestos/cement can be dangerous
e.g. when it is being drilled, sawn, or broken.

HINT: **YOU SHOULD WEAR A MASK** to avoid breathing
asbestos dust .

"TAP", the manufacturers of A/C products, offer advice
on how to use them. When you are buying A/C sheets, ask or send for a
free booklet of instructions. The address is.

TAP Building Products Ltd
Chester House
Cairo Road
Lusaka PO Box 31522 Tel: 01 211705

Builder's Line

is a very valuable "tool".

It is worth its money. When pulled tight, it does not "sag"

It is useful for checking anything which should be straight, e.g. walls, pur-
lins, trusses, edges etc

Ceilings

help to keep out heat, sound, dust, animals

Plan a ceiling carefully

Calculate the position of the bracing.

Start from the centre and work towards the walls.

Avoid having small pieces at the edges

Doors

should be made of hardwood.

Select the type of door depending on the location, e.g. Panel doors for the
main entrance, "ledged and braced" for stores and toilets etc

When fitting a door, leave a gap of 2-3mm all the way round to prevent the
door sticking, especially in the rainy season

After fitting, the door should be removed to be painted on the bottom
Only use screws in door hinges and locks
Never leave nails or screws in the timber of a door. They will damage tools in the future.

Entrances

to the project should be wide enough for a vehicle.
Before heavy trucks deliver materials, check any culverts they must pass over

Files

are useful for sharpening tools and smoothing rough metal.
Make sure your supervisor has at least 2.

Glue

Always read the instructions carefully
PVA glue is the most common glue
It is sold as wood glue but can be used on most surfaces except under permanently wet conditions

HINT : If a wall is very absorbent and difficult to paint, try sealing it before painting with a solution of 1 part PVA glue with 2 parts water.

Hasps

are more durable than many mortice locks
Fix them with screws.

Iron

rusts.
The rust makes the iron swell.
In concrete, the swelling will break it
Always clean off surface rust with a "wire brush" before pouring concrete round it.

HINT If it is in a wall and near the surface, paint it with oil paint before covering with plaster

Joints

in wood should be tight.
Joints in mortar should not be in a straight vertical line

Key

describes the roughening of a surface
e.g sandpapering oilpaint before applying
another coat, scratching the surface of concrete to help the plaster stick

HINT When making concrete lintols, remove the side shuttering the day after pouring and scratch the sides with a sharp nail

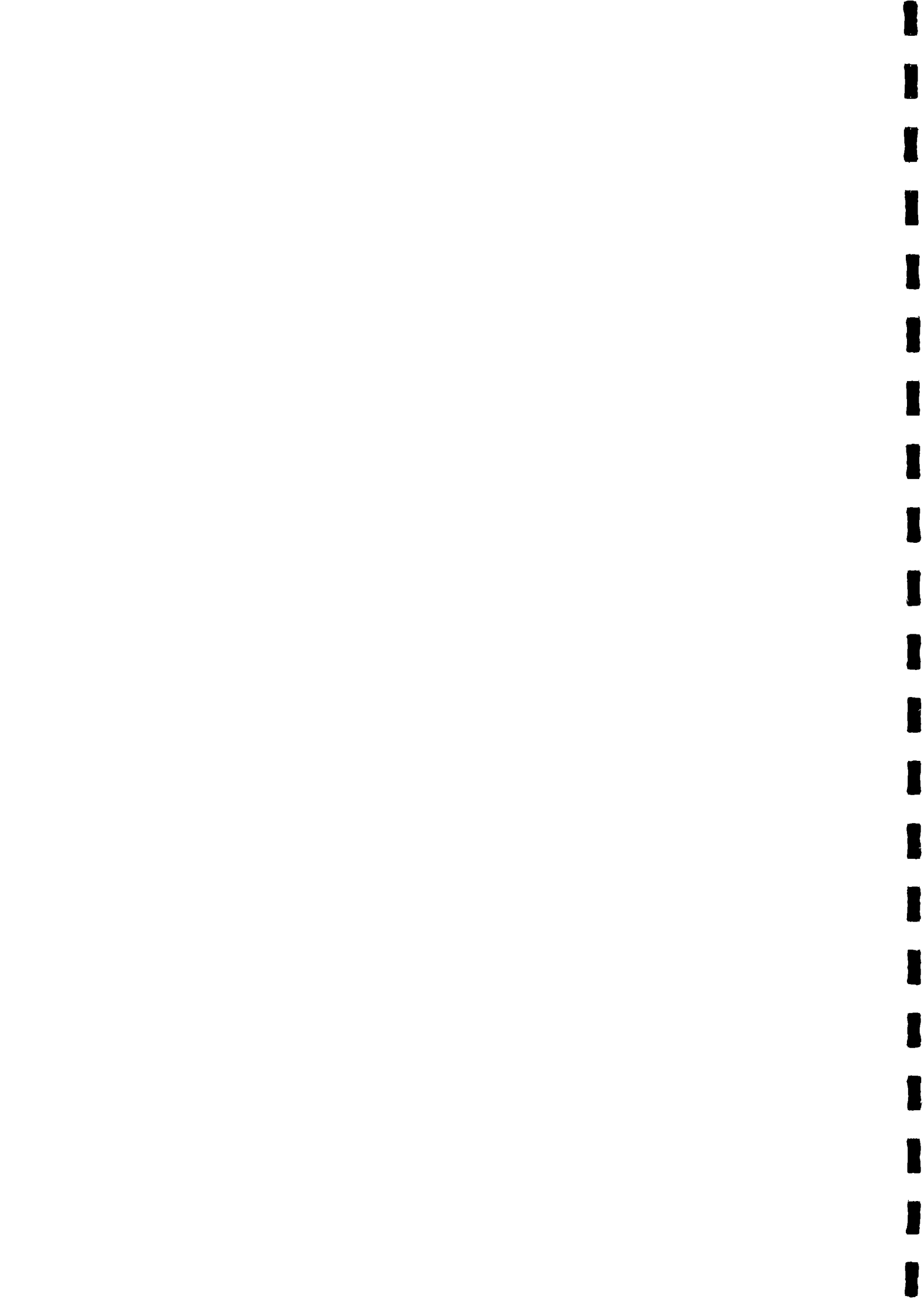



Lime

is builders' lime Agricultural lime (much cheaper) must not be used in building

It can be added to plaster and mortar, replacing up to a third of the cement content.

It makes the mix easier to work with

"Whitewash" is lime and water

HINT : Make whitewash more hardwearing by including a little (10%) cement in the mix

Note : lime is usually sold in 25kg bags, not 50kg like cement

BE CAREFUL - lime can burn your body, do not let it splash in your eyes!

Moulds

are specially shaped containers which keep something in shape, usually until it sets e.g. concrete

The mould could be for a lintol, a well liner or an ornamental block.

HINT Clean the moulds well and lubricate the insides before filling

Neon Lights

are "tube lights"

They are expensive to buy but cheap to use

They are good for public buildings.

HINT : Buy extra starters and spare tubes

Oil

Use it for wheelbarrows, sharpening stones, hinges and moulds etc

HINT : Wipe all tools with an oily cloth after work

Priming Coat

is the first coat when painting

It seals and protects the surface.

HINT . Prime the backs of cover strips and behind wooden door frames

Quarries

are pits dug to provide rock, sand or laterite

HINT Always make a deep loading bay so that the workers load the vehicle by shovelling downwards

Ridges

should be very straight.

Use a builders' line to check the purlins and make certain that the top purlin is in the right place

HINT : Buy finials to make a neat finish to the roof

Straight Edge

is used to check levels and that surfaces are flat

It is often used as an extension of the spirit level

HINT : Select a seasoned and straight piece of hardwood timber about 2m long x 120mm x 18mm
Make it perfectly straight and use it ONLY for accurate alignment

Taps

come in many designs

The best and strongest are the self closing spring type

Undercoat

is the layer of paint applied before the top or finish coat

HINT If you want a good finish always invest in a good quality undercoat

Varnish

is an attractive way to seal and protect wood

The first coat should be very thin to help penetration.

Wind

can cause severe damage.

Tie all roofs down securely and do not have big overhangs

HINT : the roof is very vulnerable when the sheets are being laid - once you start, don't stop

Xtras

Plan well and allow for contingencies.

Young

people are strong, enthusiastic and willing to learn

Involve them in the community's project

Zambia

needs your efforts - work for a better future





Glossary of Technical Terms

GLOSSARY OF TECHNICAL TERMS:

A/C sheets	asbestos cement roofing sheets
aggregates	the materials that are mixed with cement to make concrete and mortar
apron	the area of concrete laid around a well or at the down stream side of a bridge or culvert
backfill	the hardcore or laterite used to refill excavations in building
bay	a slab is divided into sections called "bays" to avoid problems associated with pouring a very large slab
bond	the pattern of bricks laid in a wall
brickforce	reinforcement used in walls
building sand	fine sand (also called pit sand)
brandering	wooden supports to which ceiling boards are attached
camber	the angle on a road to improve drainage
cast	making something into a particular shape
cast in-situ	casting in place, eg casting a lintol on a wall
cill	the ledge under a window or door to drain water away
compacting	hammering concrete or hardcore to make it stronger
conforce	reinforcement used in floor slabs
culvert	drainage pipes laid under a road
curing	hardening process of concrete and plaster
damp proof course	laid in walls above slab level to stop damp
damp proof membrane	plastic sheets laid under a floor slab to stop damp rising

darby	tool used in plastering
edge boards	planks laid to divide floor slabs into sections (bays) when pouring concrete
emulsion	water based paint (also called PVA)
expansion gaps	gap between areas of slab on outside floors
fill	hardcore or laterite base under a floor
float	flat metal or wooden tool used to smooth concrete and plaster
floor screed	thin top layer of a floor
footing	concrete layer at the bottom of the foundation trench
foundation wall	bricks or blocks below slab level
foundation	material, usually concrete, on top of which a building is erected
gables	pointed end walls of a building
gloss	oil based paint
grading	process of getting rid of the wrong sized material
hardcore	mixture of strong, coarse materials such as stone, gravel, broken bricks, etc.
laterite	strong, ancient, washed out, red coloured soil, commonly known as gravel in Zambia
levelling	making sure something is exactly horizontal
line level	small spirit level which is hung on a line to check foundations, slabs etc are horizontal
lintols	beams put over door and window openings, usually reinforced concrete
load bearing walls	walls which have to support a considerable weight e.g the roof or an upper floor
mass concrete	concrete which includes large stones (up to 6cm across) in the mix

mix	the collection of materials used to make concrete and mortar
mortar	cement and sand mix used to fix bricks in place
mould	container used to give a special shape to some material e.g. concrete lintol, brick
non-load bearing walls	walls which do not have to support any additional weight
parts	the term used to describe the quantity of each material in a mix
pit sand	fine sand (also called building sand)
plaster	mortar mix used to cover walls
plumb	vertical
plumb bob	tool used to check something is vertical
pointing	tidying up mortar joints in brickwork or blockwork
pre-cast	concrete which is cast at some distance from its intended final position
profile boards	boards used in setting out a building
purlins	supports which roof sheets are fixed to
putty	used to fix window panes into frames
PVA	water based paint (also called emulsion)
rafters	large roof timbers
raking out	removing a little mortar from joints to provide a good surface for plaster
rebar	metal rods used to reinforce concrete
reinforced concrete	concrete strengthened with metal
ridge	top of roof
ring beam	strip of reinforced concrete laid completely around walls to give a building more strength

river sand	coarse sand
roof ties	wires built into walls and used to fix down roof timbers
rubble	any solid waste material e.g. broken blocks, bricks and stones
screeds	strips of accurately laid plaster
seasoning	drying process for timber
septic tank	tank used to clean up waste water
setting out	process of marking where foundation trenches will be dug
settling	normal process of a building drying out and/or compressing the soil it is built on
shrinkage gaps	gaps left between sections of slab on indoor floors
shuttering	sides of a mould
silt	very fine particles in soil - between sand and clay
slab	large area of concrete support for a floor
soakaway	large pit filled with stones, rubble, etc
solar panels	special panels used to change sunlight into electricity
spirit level	tool used to check things are horizontal and vertical
square	exactly 90 degrees, or a right angle
stable soil	firm, undisturbed soil which will support a building and not change shape whether wet or dry
straight edge	length of metal or wood, used to check things are straight
strike board	flat length of timber, used to level concrete
subsidence	when a building collapses due to being built on unstable soil
tampers	heavy weight, used to compact concrete

timber	sawn wood
topsoil	the soil nearest the surface best for plants but not stable enough for building
trusses	large triangular wooden structures supporting the roof
unstable soil	weak soil, such as clay or very loose sand
V.I.P.	Ventilated Improved Pit Latrine
wall plate	timber laid on top of a wall, which the roof timbers are attached to
warping	bending and twisting of wood as it dries



Index

INDEX

AIR BRICKS	104
ANT GUARD	101
ANT TREATMENT	
Foundation	83
Floor	87
Timber	120
ASBESTOS SHEETS	see roof
BACKFILL	
General	76
Foundation	82
BAYS	91
BLOCKS	
For foundation Wall	81
Bonds	99
Laying	100 et seq
BONDS	99
BRICKS	
Soil for	20
Moulding	23
Drying	26
Firing	29
Testing	30
For foundation wall	91
Slabs	68,94
Bonds	99
Laying	100 et seq
BRICKFORCE	
General	46
Foundation wall	82
Main Walls	104
BURGLAR BARS	114
CEILINGS	157

CEMENT	35
CHECKLIST	6
CILLS	111
COMPACTING	
The footings	80
The backfill	82
The fill	87
The slab	93
CONCRETE	
Mass Concrete	42
Reinforced Concrete	42
Pouring and Compacting	43
Curing	43
CONFORCE	
General	46
Slab	92
CORNERS	
Foundation wall	81, 103
General	103
CULVERT	172
DAMP PROOF COURSE	102
DAMP PROOF MEMBRANE	88
DOORS	
General	140
Rehabilitation	156
DRAINAGE	
General	150
Wells	168
Roads	172
DRY MIX	40
ELECTRICITY	
General	144
Rehabilitation	158
EXPANSION GAPS	93

FANCY BLOCKS	
General	110
Fitting	110
FILL	
	87
FLOOR	
Parts of	86
Slab	88
Screed	95
Inside	93
Outside	94
Rehabilitation	155
FLOOR SCREED	
General	95
Rehabilitation	155
FOOTINGS	
General	76
Depth	79
Pouring	80
FOUNDATION	
General	76
Setting Out	68
Rehabilitation	155
FOUNDATION WALL	
General	76
Effect on slab	89 et seq
FOUNDATION TRENCH	
Setting Out	68 et seq
Digging	108
FRAMES	
General	108
Fitting	109
GABLES	
	105
G.I. SHEETS	
	see roof
GLASS	
General	109
Thickness	139

GLOSS	136
GRADING	37
GUM POLE TRUSSES	125
KILN	
Siting	21
Preparing	27
Wood for	28
Firing	29
LIME	45,160
LINTOLS	111
LOAD BEARING WALLS	100
MITRE DRAIN	173
MIXES	34
MIXING	
Quantities	34,38
Method	40 et seq
Slab	65
MORTAR	
General	44
For walls	98
Bed	100
NON-LOAD BEARING WALLS	100
PAINTING	136
PATHS	66
PARTS	38
PLANS	
General	10
How to use	13
PLASTER	
General	44
Application	132
Curing	136

PLASTERING	
General	132
Foundation Wall	81
PLUMBING	147
POINTING	107
PROFILE BOARDS	
Making	68
Number of	73
PURLINS	
Planning	123
Fitting	126
PUTTY	140
PVA	136
RAFTERS	127
RAKING OUT	106
REBAR	
General	46
Lintols	111
VIP slab	54
REHABILITATION	153
REINFORCING MATERIALS	46
RIDGE	123,129
RING BEAM	79
RINGS	164
ROADS	171 et seq
ROOF	
General	118
Coverings	121
Planning	122
Fixing	128
Rehabilitation	157

ROOF SHEETS	
Planning	122
Fixing	128
ROOF TIES	105
SAND	
Types	35
Testing	36
SCREEDS	
Floor	95
Plaster	134
SECTIONS	12
SEPTIC TANK	
New	147
Rehabilitation	158
SETTING OUT	68
SETTLING	132
SHRINKAGE GAPS	93,96
SITING	
Buildings	62
VIP's	52
Wells	162
SLAB	
General	88
Laying	88 et seq
Brick slabs	94
For a VIP	54
SLOPE	
Building on	74
SOAKAWAY	169
SOLAR POWER	145
SQUARE	69 et seq
STONES	37

SUBSIDENCE	76
TAMPER	43
T.A.P.	118
THINNERS	137
TIMBER	119
TILES	121
TOOLS	16
TOPSOIL	68
TREES	62
TRUSSES	
General	118
Fitting	124 et seq
UNDERCOAT	136
UNSTABLE SOIL	
Changes to foundation	76,79
Changes to VIP	58
Siting	62
VERANDA POLES	83
VI.P.	
How it works	50
How to build	52
WALLS	
Setting Out	69 et seq
General	97 et seq
Rehabilitation	155
WALL PLATE	
General	118
Fitting	123
WATER	
In concrete	41 et seq
In Mortar	45
Pit	65
Tanks	147

WELLS	
General	161
WET MIX	41
WHEELBARROWS	39
3-4-5 METHOD	70

