

Department of  
Development Support &  
Management Services

# FERRO- CEMENT RAINWATER TANKS

English

oia

Tivulu

213.2-14870

RAS/92/304  
TUV/87/006





UNITED NATIONS DEVELOPMENT PROGRAMME

*Prepared by*

Department of Development Support & Management Services

# **FERROCEMENT RAINWATER TANKS**

English

and

Tuvalu

LIBRARY IRC

PO Box 93190, 2509 AD THE HAGUE

Tel.: +31 70 30 689 80

Fax: +31 70 35 899 64

BARCODE: 14870

LO:

213.2 94FE

February 1994

UNITED NATIONS DEVELOPMENT PROGRAMME

Department of Development Support & Management Services



---

## **FAKATOMUAGA**

---

### **Fakatomuaga: Tani vai sameni pukupuku**

Te tusi tenei se tusi e tasi i tusi kola ko oti ne fakatoka ke fesoasoani kite fakaakoakoga o tino galue iluga ite tausiga mote tufaga o vai ite pasifika.

Te aoga mote fakamoemoea ote tusi tenei kote mea keiloa ne tatou o:

- Sala se koga lei mo fakatu ei te tani vai
- Fakatoka te tulaga ote tani
- Maaka kae fakatoka te tulaga ote tani
- Fakapiki kae fakatu a pusa ote tani
- Ofe kae fakamoe a fiti fakamakeke ikoga tonu o latou
- Soko ate paipa ke toka
- Fua fakalei ate palu sameni mo palasita
- Palasita a pui ote tani
- Faite ate pono ote tani
- Fakasiu ate tani kae fakaotioti ate galueaga

---

## **INTRODUCTION**

---

This guide is one of a series of booklets designed to support practical training for those workers engaged in providing basic water supplies and sanitation for rural communities in the Pacific region.

The principal aims and objectives of this guide are to:

- Identify suitable sites for storage tanks
- Prepare the site for tank construction
- Mark out and set up the base
- Construct and erect tank formwork
- Bend and place reinforcement in position
- Prefabricate pipe connections
- Proportion and mix cement mortar
- Plaster tank walls
- Construct tank covers
- Cure tanks and complete ancillary works

(Words in *italics* are defined in the glossary at the back of this manual.)

---

## **TANE VAI SAMENI**

---

1. Ate fakalavelave tenei e tupu soko ki tino ote Pasifika, kote seai ne koga mo tausi fakalei a vai inu. Ite lasiga o fakai, te vai tela e fakaoga malosi kae maua gofie ne latou kote vaiua tela e fakatali mai tuafale ki loto i tani vai io me ko vaisameni.

2. Te auala tenei e fakaigoa kite fakataliga o vai mai te vaiua kae manakogina keiloa ne te lasi ote tuafale:

Te lasi ote tuafale - kote koga e tali ei te viaua

Alaavai mo alaapaipa - mea nei ko mea kola e fakatali kae fakasali ei a vai mai te tuafale ki loto ite tani

Tani - E tausi ei a vai ite taimi e to ei te vaiua kote mea ke mafai ofakaoga i taimi ote tau la

Paipa mote kii- ko mea kola e mafai ei ne koe fakasoasoa au vai mai loto ite tani

3. Te auala tenei io me kote faifaiga tenei e mafai foki o fakamuna penei:

**TE AOFAKI VAI E MAUA - TE AOFAKI VAI  
E FAKAOGA = LASI OTE TANI**

TE AOFAKI MAUA kote vai aoga e maua mai te tuafale

VAI FAKAOGA kote aofaki vai e fakaoga ne tino ite kaiga/aso

Te TANI e manakogina auua me ite vai maua e kese te taimi e maua ei latou mai te vai tela e fakaoga ne koe mai loto ite tani



---

## FERROCEMENT TANKS

---

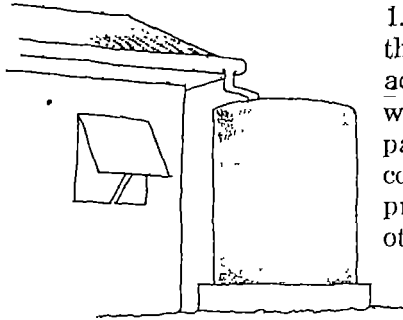

1. A constant problem for many people throughout the Pacific Region is the lack of access to an adequate supply of safe drinking water. However, for many people and particularly those in rural areas, rainwater collected from roofs and stored in tanks can provide sufficient water for drinking and other uses.

2. This method is often referred to as a rain water *catchment* system and requires:

Roof Area	-Catches rain when it falls
Gutters and Down Pipes	-Pass rain from roof to tank
Tank	-Stores water when it rains so that it can be used when there is no rain
Delivery Pipe with Tap	-Allows stored water to be used carefully and safely

3. The system can be described as:

$$\text{INPUT} - \text{OUTPUT} = \text{STORAGE}$$

INPUT is the volume of useful rainwater from the roof.

OUTPUT is the volume of rainwater used by the consumers.

The STORAGE is needed because the input occurs at different times and rates from the output.

---

## Tane Vai Sameni

---

4. E isi foki ne tusi penei ko oti ne fakatoka kola e fakaasi mai e auala kite fakatutu mo niisi auala kola e autu tonu ki faifaiga penei. Konei auala kona:

- a) Tuafale, Laukaapa, Alaavai, Alaapaipa
- b) Tani sameni pukupuku
- c) Paipa palasitiki maakaga mote fakapikiga o paipa; fakatokaga galuega tau palama; atega o paipa kii

A tusi konei e maua ite Ofisa ote Matagaluega Faka Tutu.

5. Te tusi tenei e fakautu tonu loa mo tani vai pukupuku.

6. Ate masani mote mea eiloa nei me, i tani e mafai o faite mai vaega auala e uke. Konei niisi auala:

- tani sameni pukupuku
- vaisameni fai ki pusa
- vaisameni e fai ki puliki
- laufiti kalavanaisi
- alaminiamu
- laufiti fakapikipiki
- faipa kilaasi
- palasitiki

7. Tani sameni e fakatusa io me fakailoa mai me ko uaea fakapakeke mo sameni/one kola e palu kae palasita kise matolu tela e mafai neia o taofi te vai kae moaa e mapaa. Tani sameni penei ko lasi te fakaoga ite ukega o fenua, kae kesekeese a faitega ona kote kese o tau o aso.

**Kafai mea ne fai kiei te galuega e lei kae lei foki te faitega ote tani ate tani tena ka ola leva (tusa kite 50 tausaga).**

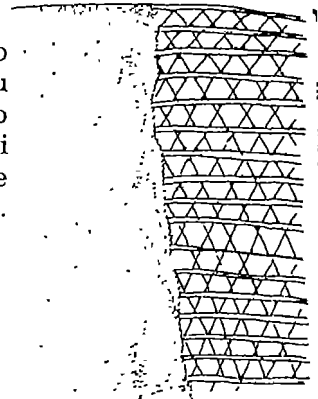

---

## **Ferrocement Tanks**

---

4. A series of booklets have been prepared outlining the constructional techniques (and other aspects) of the parts of the system.

They are:

- (1) Roof Catchments; Roof Coverings; Guttering and Down Pipes
- (2) Ferrocement Tanks
- (3) Plastic Pipework; Marking Out and Installing Pipework; Sanitary Plumbing; Repairing Taps and Valves

These booklets are available from the Public Works Department and the regional project in Suva, Fiji.

5. **This booklet deals with ferrocement tanks.**

6. In practice, tanks can be made from a variety of materials. The most common are:

- ferrocement
- reinforced concrete
- blockwork with cement plaster (rendering)
- corrugated galvanised steel
- zinc/aluminium alloy coated steel
- prefabricated metal sections
- fibre-glass (with metal rods )
- plastic or rubber lining
- prefabricated timber

7. Ferrocement refers to the use of fine wire reinforcement with a sand/cement mortar to form a thin layer which is resistant to loads, in this case, water pressure. Ferrocement tanks have been in use in a number of countries for many years and subjected to varying climatic conditions.

**Providing that good quality materials are used and care taken during construction (as outlined in this booklet) the life of the tank could exceed 50 years.**

---

## Tane Vai Sameni

---

8. Tani sameni ka gasolo o takutakua ona:

- kote toka o mea faigaluega pela mokilikili mo one
- e faigofie te faiga (se manakogina mea faigaluega uke)
- e tau mamaa

E mafai foki:

- tino ote fakapotopotoga ofesoasoani kite lukuga o kilikili mo one
- e tai faifaigata o masei a mea konei ite taimi e aveave ei iluga ite tulkita kae tau tatou o ono ono kite tausiga fakalei o sameni ke moaa e siu
- pusa kafai ko oti ne akapikipiki emafai o toe fakaoga

9. Mea faigaluega kola e fakaoga ite faiga ote tani sameni:

- pusa e fai ei te tani, pokisi fua, pinisi paa
- sameni, vailakau, vai, laupapa mo palu
- fiti uaea fakapakeke, uaea saisai, uaea o paamo
- one, kilikili, fakamaa
- sevolo, alofilima, laupapa faka maniania
- pakei palasitiki, laupapa tonu
- samala, palaea mea kati fiti, soa, tofi
- teipe fua, fua vai fua fakatautau
- pepa palasitiki
- paipa mo olotou soko

(kafai e toka, se mesini palu tona uiga ka faka foliki neia te taimi e palu ei io me kote taimi e faite ei te tani)

---

## **Ferrocement Tanks**

---

8. Ferrocement tanks are becoming more popular because they:

- can be built using local materials - sand and aggregate
- require simple construction techniques involving basic hand tools and semi/unskilled labour
- are a cost effective method of construction.

In addition there can be:

- community involvement in the gathering of local materials and construction
- less chance of damage to non-local materials during transportation, however, cement must always be carefully stored and kept dry
- formwork if prefabricated, can be re-used.

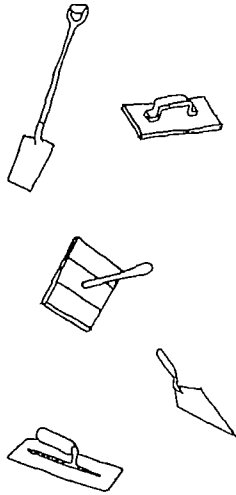

9. The equipment and materials required to construct a ferrocement tank include:

- tank moulds, gauge box, pinch bar
- cement, additives, water, mixing board
- steel rods, mesh, tie wire, chicken wire
- sand, aggregate, sand sieve
- shovels, trowels, floats and *builder's hawk*
- plastic bucket, *slump cone*, straight edge
- claw hammer, pliers, bolt cutter, saw, chisels
- tape measure, spirit level, plumb bob, line level
- sacking or plastic sheets
- pipe and fittings.

(If available, a concrete mixer will reduce the labour of mixing concrete and mortar).

---

## Tane Vai Sameni

---

10. E uke ki auala e faite ei a tani sameni. Te lasiga e faite maite fakatokaga ote pusa kae sai kiei te uaea tuanki kae palasita ki sameni ko oti ne palu.
11. Ate suaqa vaegaa tani e manakogina e fano kiluga ite toka o mea e fai ei te tani pela foki mote vaegaa tani ko masani kiei a tino. E tau tatou o tautali ki fakanofoaga mo ata kola ko oti loa ne fakatoka. Kafai la seai io mese toka ne ata kote tusi la tenei e aoga o tautali tatou kiei. Taumafai foki o fesokotaki mo tino fakatutu io me ko tino tausii te olaga io me sose tino tela e toka o fesoasoani kite faiga o vaega mea penei. Kafai ko isi ne tani ko oti ne faite mua, sokotaki kite tino ne fai neia fesili kiei me nea a faigataga ne oko kiei ko mea ke sala ne koke se auala ke fakalei ei te faiga i aso mua.

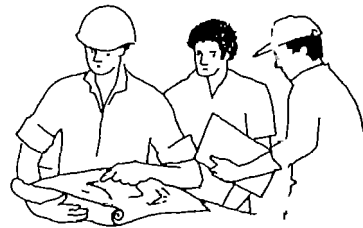

---

## **Ferrocement Tanks**

---

10. There are many ways of making ferrocement water tanks. Generally, they are built by forming a framework covered with a fine wire mesh which is plastered from both sides with a cement mortar.

11. The shape and size of a ferrocement tank varies considerably. It depends to a large extent on availability of materials and local conditions and practice.

Where there are local standards for design and construction these should be followed. Where there are no standards, this booklet provides guidance on the techniques of construction which should be followed. However, when possible, consult local health officials, builders or anyone who is in a position to offer sound, practical advice. If possible, examine tanks which have been built locally and consult the builders about the construction; what problems arose, if any, and suggestions for improvement.

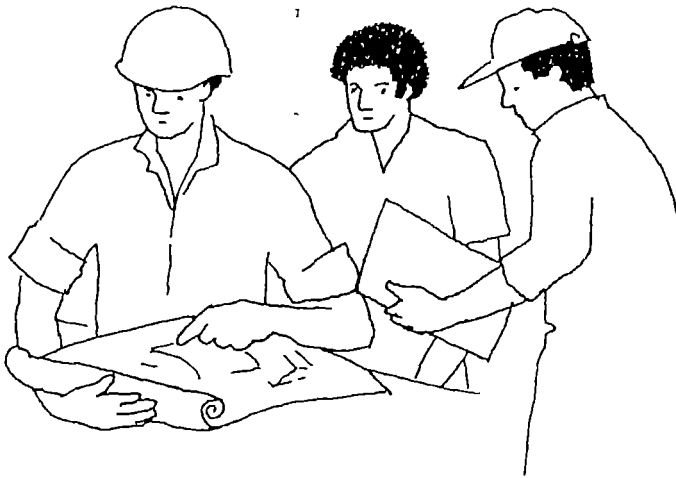

---

**FAKATOKAGA MO MEA MO FAI TE GALUEGA**

---

12. Koi tuai o fakatu te tani e tau o iloa ne koe

Te lasi ote tani - e mafai o iloa mai te lasi ote tuafale mote lasi ote vai e  
fakaoga ne te kaiga ite aso

Te koga e fakatu iei - te faigataga maafai te laukele e fatufatua io me  
pelapela

Faitega - vaega mea fai kiei te galuega, te faigofie o maua mote togi o latou  
(me mafai ne tino o togi)

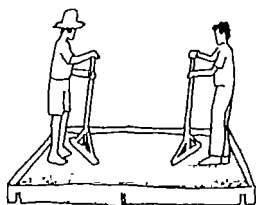



---

## SIZE AND MATERIALS

---

12. Before construction begins, several important decisions must be made. They include:

**Size of Tank** - this is dependent on the available roof area, and the expected daily water consumption of the family (or other consumers)

**Siting of Tank** - this must be on level ground with a solid foundation and ready access to household users

**Construction** - this depends on what type of materials are available and must be of affordable cost

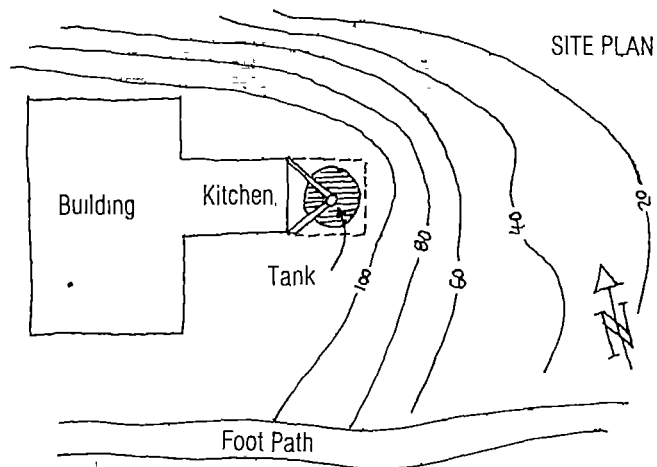

---

## Fakatokaga Mo Mea Mo Fai Te Galuega

---

13. Tani sameni konei pukupuku. Te lasi o ia e mafai o maua mafai e fakaoga te auala tenei.

$$\text{Lasi} = .70 D^2 H \text{ mai } 3.14 (D^2 \div 4) \times 0.9H$$

D = kote lasi ote tani iloto

H = kote maluga ote tani mai tua

Te mea tena ka mafai ei o maua ei ate koga e tu ei ate fakatali ote tani

Fakatusa:

Galue mai te lasi ote tani maafai te lasi iloto e 2.5 mita kae 2 mita te maluga itua ote tani (1 mita = 3.28 futu)

$$\text{Te Lasi} = .70 \times 2.5 \times 2.5 \times 2 = 8.75 \text{ kupiki mita}$$

1 kiupiki mita = 1000 lita (220 kalone) Te lasi la ote tani = 8,750 lita (1.925 kalone)

Kafai ko kilo tatou kite fakaogaga ko iloa ne tatou te aofaki aso ka sua ei te tani i vai.

FAKAOGAGA	ASO
25 lita/aso	350
50 lita	175
100	87
200	43
300	29

te aofaki vai e tau mote tino o fakaoga ite aso e 50 lita (rela: kote 200 lita ite oko fa tino)

---

## Size and Materials

---

13. Ferrocement tanks described in this booklet are circular. Their storage capacity can be calculated from the approximation:

$$\text{Capacity} = .70 D^2 H \text{ from } \pi D^2 \div 4 \times 0.9H$$

where,

D = internal diameter of the tank

H = external height of the tank side wall

This makes some allowance for the position of the draw off from the tank and the overflow.

For example:

- Calculate the capacity of a tank of internal diameter 2.5 metres and a side wall height of 2 metres.

(Note: 1 metre = 3.28 feet)

$$C = .70 \times 2.5^2 \times 2 = 8.75 \text{ cubic metres}$$

As 1.00 cubic metres = 1,000 litres and as 1,000 litres = 220 Imperial (or U.K.) gallons, then :

Capacity = 8,750 litres (1,925 U.K. gallons).

Note: To convert litres to U.K. gallons, 1.00 u.k. gal. = 4.55 litres and to convert litres to U.S. gallons, 1.00 u.s. gal. = 3.78 litres.

Allowing various daily *consumptions*, a tank of 8,750 litres would provide water for storage depending on consumption as follows:

Consumption	Storage Days
25 litres per day	350
50 "	175
100 "	87
200 "	43
300 "	29

A suitable personal allowance would be 50 litres per day (i.e. 200 litres for 4 people).

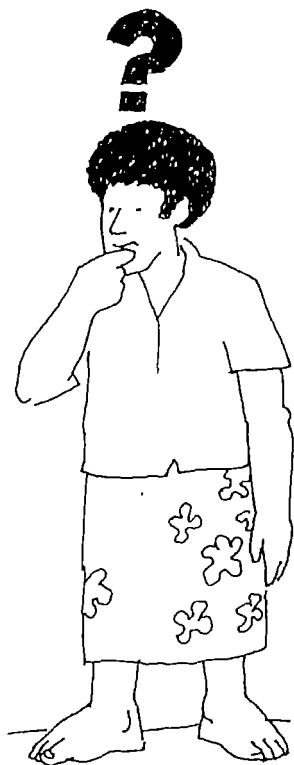

---

## Fakatokaga Mo Mea Mo Fai Te Galuega

---

14. Te mafa ote 1 lita vai e 1 te kilokalame. Tela la te 1000 lita tona mafa e 1,000 kilokalame tela foki kote 1 tane. Mai te fakatusa la tela, 8.75 kiupiki mita tona mafa 8.75 tane (1 kilokalame = 2.20 pauna) Te vai e isi se matagi tela e maua mai lalo ote kilikili vai kae se kote saisi mote ata ote tani Te matagi tenei e fua iluga i kilopasikela (KPa). Ite 1 mita poko ote vai ate matagi e maua mai ite koga tena e 9.81 KPa. E matea ne koe me ite matagi tenei e fanaka itafa ote pui ote tani mafai e fanaifo koe kite pokoga ote tani io me kote muli ote tani. Ate tani e tau o faite ke mafai neia o teke ate matagi tenei, tela te mea e uke e a uaea fakapakekeke ite mulitani mafai e fakapau kite aofaki tela ne fakaoga iluga ote tani.

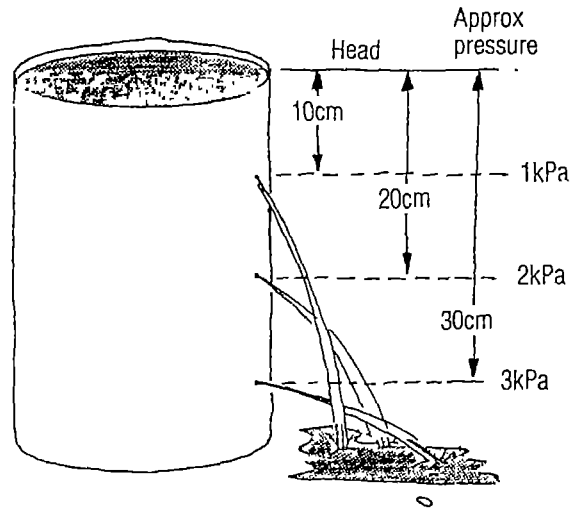

15. Mo tani penei ate fakaogaga tau o mea e faite kiei ate tani e mafai ate lasi iloto ote tani e pau mote maluga itua ote tani. Kote masani nei ate maluga ote tani e iloa tonu mafai e iloa te mao ote laukele mai te fakatali ote tuafale. Kafai ko faite a tani penei e tau o tuku kise saisi e tasi ate lasi ote tani iloto kae faka kesekese te maluga.

---

## Size and Materials

---

14. One litre of water weighs one kilogram. Therefore, 1,000 litres weighs 1,000 kilograms which is also 1 tonne.  
Thus from our previous example, 8.75 cubic metres weighs 8.75 tonnes.  
(Note: 1 kilogram = 2.20 lb.)

Water exerts a pressure which depends on its depth below the surface of the water and not on the shape or size of the tank. Pressure is measured in *kilopascals* (kPa). To convert to pounds per square inch:  $6.9 \text{ kPa} = 1.0 \text{ psi}$ .

A 1 metre depth (or head) of water exerts a pressure of 9.81 KPa at that depth. It can be seen that the pressure on the side wall increases with depth to a maximum at the bottom of the wall which also applies to the base.

The tank has to be designed to resist this pressure. In the case of the ferrocement tank, it is the reason why there is additional reinforcement at the bottom of the wall in comparison with the top and why a separate base is provided under the tank.

15. In theory, for a particular tank capacity, the best use of materials is made when the internal diameter and side wall height are the same. However, the height is often controlled by the distance between the ground and the rain water gutter.

When a number of tanks are being built, it is generally best to standardise on the diameter and adjust the height to provide different volumes.

## Fakatokaga Mo Mea Mo Fai Te Galuega

16. Kafai ko iloa tonu te saisi ote tani e tau o fakatoka te pepa kei loa te aofaki o mea e fai kiei te tani kae tau foki o ulu katoa mesini mo tino galue

Table 1					
QUANTITIES AND ESTIMATES					
FERROCEMENT TANKS					
Nominal Volume:	cu. m	12.0	8.4	9.0	5.4
US gallons	us gal	3170	2200	2380	1430
UK gallons	uk gal	2640	1850	1980	1190
Nominal Diameter Internal	m	2.50	2.50	2.50	2.50
" Height External	m	2.60	1.90	2.00	1.30
" Wall Thickness	m	0.05	0.05	0.05	0.05
Main base thickness	m	0.10	0.10	0.10	0.10
" " length of side	m	2.90	2.90	2.90	2.90
Mortar (1 2) for tank	cu m	1.57	1.27	1.33	1.03
Concrete (1 2 4) for base	cu m	0.84	0.84	0.84	0.84
Sand (moist)	cu m	2.64	2.24	2.32	1.93
Aggregate	cu m	0.78	0.78	0.78	0.78
Cement	tonne	1.45	1.25	1.30	1.05
Waterproofing (felproof)	litres	14.3	11.6	12.1	9.4
Length of 4 mm wire	m	327	245	262	196
" 1.6 mm tie wire	m	18	13	14	10
Area of chicken wire	sq m	52.5	44.8	49.1	36.8
Area of F62 mesh	sq m	8.7	8.7	8.7	8.7
20 mm pipe	m	1	1	1	1
20 mm tap adaptor	No	1	1	1	1
20 mm tap	No	1	1	1	1
20 mm elbow (90° bend)	No.	3	3	3	3
Labour-craftsman	man days	4	3	3	3
" -unskilled	" "	11	10	10	8
* Tractor and trailer	hours	6	5	5	4
* Concrete mixer	"	7	6	6	5
* Vibrator	"	1	1	1	1

## Size and Materials

16. Once the size of the tank has been established, a materials list should be prepared. A good list details the quantities of materials that are needed to build the tank and may also include information on labour and plant requirements.

Nominal Volume:	cu. m	12.0	8.4	9.0	5.4
US gallons	us gal	3170	2200	2380	1430
UK gallons	uk gal	2640	1850	1980	1190
Nominal Diameter Internal	m	2.50	2.50	2.50	2.50
" Height External	m.	2.60	1.90	2.00	1.30
" Wall Thickness	m	0.05	0.05	0.05	0.05
Main base thickness	m.	0.10	0.10	0.10	0.10
" " length of side	m	2.90	2.90	2.90	2.90
Mortar (1.2) for tank	cu m	1.57	1.27	1.33	1.03
Concrete (1.2 4) for base	cu.m	0.84	0.84	0.84	0.84
Sand (moist)	cu.m	2.64	2.24	2.32	1.93
Aggregate	cu m	0.78	0.78	0.78	0.78
Cement	tonne	1.45	1.25	1.30	1.05
Waterproof (febproof)	litres	14.3	11.6	12.1	9.4
Length of 4 mm wire	m	327	245	262	196
" 1.6 mm tie wire	m.	18	13	14	10
Area of chicken wire	sq.m.	52.5	44.8	49.1	36.8
Area of F62 mesh	sq.m.	8.7	8.7	8.7	8.7
20 mm pipe	m	1	1	1	1
20 mm tap adaptor	No.	1	1	1	1
20 mm tap	No	1	1	1	1
20 mm elbow (90° bend)	No.	3	3	3	3
Labour-craftsman	man days	4	3	3	3
" -unskilled	" "	11	10	10	8
* Tractor and trailer	hours	6	5	5	4
* Concrete mixer	"	7	6	6	5
* Vibrator	"	1	1	1	1

Table 1 gives relevant details for tanks associated with individual housing. It is important that all materials are available on site prior to starting and that the necessary labour, small tools, equipment and plant have been arranged. The last three items marked with an asterisk (\*) are optional - they would normally be used on large projects where many tanks are to be built in each location. An engine-driven concrete mixer has the advantage of providing a thorough and consistent mixing and can help to keep the water to cement ratio low enough for high strength concrete (when mixed by hand there is sometimes a temptation to add too much water in order to ease the effort of mixing a good stiff batch of concrete). Vibrators can be used to help distribute the concrete in the base, however, careful tamping and rodding can achieve the same effect of getting a dense concrete by eliminating any voids (gaps or holes) and getting all corners fully filled.

---

## Fakatokaga Mo Mea Mo Fai Te Galuega

---

17. Mo tani kola se fakaoga tasi vailakau mote sameni, e isi se lei mafai e fakaoga a mea penci

**febproof io me ko niisi mea aka** - e fakalei nei a ate sameni palu io me mafai foki ate one ese lei

Kafai ko fakaoga a vailakau, e tau o tautali tatou ki tusi fakatonutonu maite koga ne faite mai ei a vailakau konei

18. Kafai ko faite a tani kola e pau, a pusa e tau o faite kae fakaoga kiei. E tau foki o faigofie te fakapikiga mote talaga.

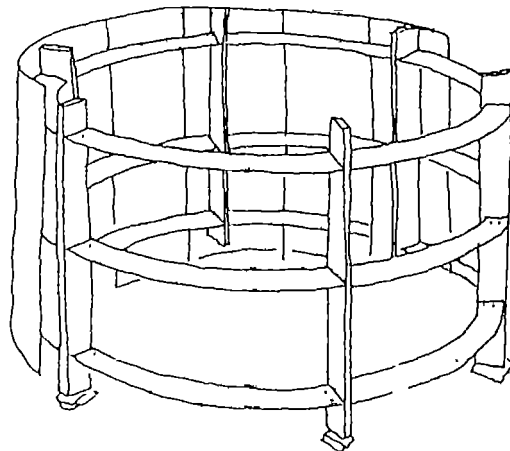
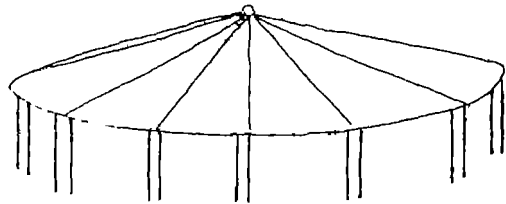



---

## **Size and Materials**

---

17. Whilst tanks can be built without using additives with cement, there are advantages in using water proofing additives.

One which has been used with good results in Tuvalu and Kiribati is **febproof**. This water-proofing compound serves to reduce the permeability of the finished mortar and to increase the workability of the mortar so that it is easier to mix and apply even with a low water to cement ratio. It is an emulsion, or organic ester, combined with a lignin-based water-reducing agent and it does not contain chlorides or nitrates, or trap air bubbles.

Where an additive is used, the manufacturer's instructions should be followed. Additives should not be used in combination without first consulting the relevant manufacturers.

18. When producing a number of identical tanks, prefabricated permanent formwork should be made and used. It should be easily put together and taken apart.

---

## **FAKATOKAGA: FAITEGA OTE TULAGA TANE**

---

19. Ite otiga ne filifili ne koe te vaega tani, e manako koe kiei, te lasi mote koga ka tu ei itafa ote fale, e tau mo koe o iloa tonu ate laukele me mafai neia taofi te mafa ote tani mafai e soko. Kafai ko keli ne koe se puuga foliki ite laukele tena e mafai ne koe o iloa te vaega laukele tena. Kafai la te laukele e se lei, e tau o fakamalosi ate fakavae ke mafai neia o tu lei.

20. Kafai te kogatena e se lei, sala se koga lei mo fakatu te tani. Ate fai fakaleiga ote fakavae kote toe mea taua loa ite galuega tenei kite fakatuuga o tani.

21. Ite otiga ne iloa tonu ate koga mo tu te tani, unu katoa, kae ta kilalo lakau kola e fakalavelave ne latou ate tulaga a tani. E tau o ateatea te tulaga tani pela foki ke avanoa te koga e galue ei a tino.

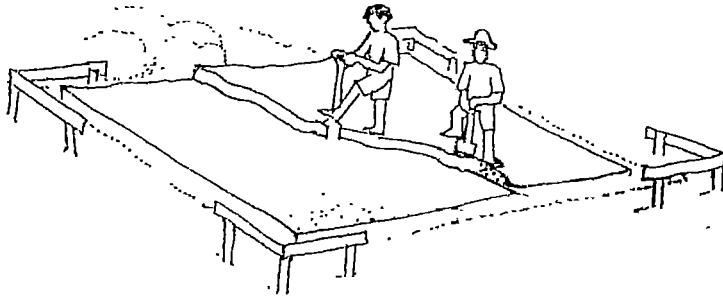

---

## **THE SITE & MAKING THE BASE**

---



19. Having decided on the type and size of tank to be built and its proposed location in relation to the building, check that the sub-soil can support the weight of a full tank. By digging a small trial hole it can be seen if the ground is soft or swampy. If the ground is unstable, a lot of work will have to be done to build and ensure a strong foundation and base for the tank

20. If the results are poor, find an alternative site if possible. The preparation of a solid foundation and base is one of the most important aspects of tank construction.

21. Having decided on the site, clear away all vegetation and other rubbish (see paragraph 30). Space is needed for the tank together with adequate room in which to work.

---

**Fakatokaga: Faitoga Ote Tulaga Tane**

---

22. Ate mao ote alaavai io me kote alaapaipa maite laukele e tau o fua keiloa kae fakapau mote maluga ote tani (e tau o fakavanoa te koga mo ulu ei te paipa fakasali). Ate tani e lei atu mafai e tai maluga te fakavae ko mea ulu lei te paketi kite paipa.

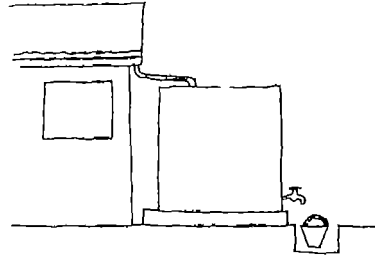

23. Te fakatokaga ote multani, fua te saisi iluga ite laukele. I koonā katoa ote tulaga tena, tuki e tolu pine ke ( $90^{\circ}$ ). Iluga i pine konci, tuki ne laupapa kiluga iei. Feitu mailuga ote laupapa tena kote maluga foki loa ote fola ote tulaga.

24. Laupapa penei e faka igoa ki polofaela. Iluga foki i laupapa konei ka tuki fao o maaka te lasi tonu loa ote tulaga.

25. Kote fakamaoniā me ilaupapa e  $90^{\circ}$  ate sukuea e fakaoga mo fakatalitōnu te mea tenei. E tolu lakau e tuki tasi kite lasi e manakogina.

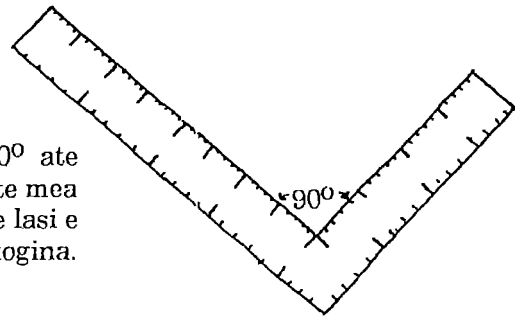

---

## The Site & Making the Base

---

22. The distance between the gutter and the ground should be measured and compared with the height of the tank plus an allowance for the down pipe system. The difference is the maximum height of the tank base above the ground. It is better to elevate the tank so that buckets can be placed under the outlet tap, to draw off all the stored water in the tank.

23. To set out the base, roughly measure the size on the ground. At each corner outside of this mark, drive in 3 stout pegs at right angles ( $90^\circ$ ) to each other. To these pegs, boards are nailed. The top of the board corresponds to the finished height of the tank base.

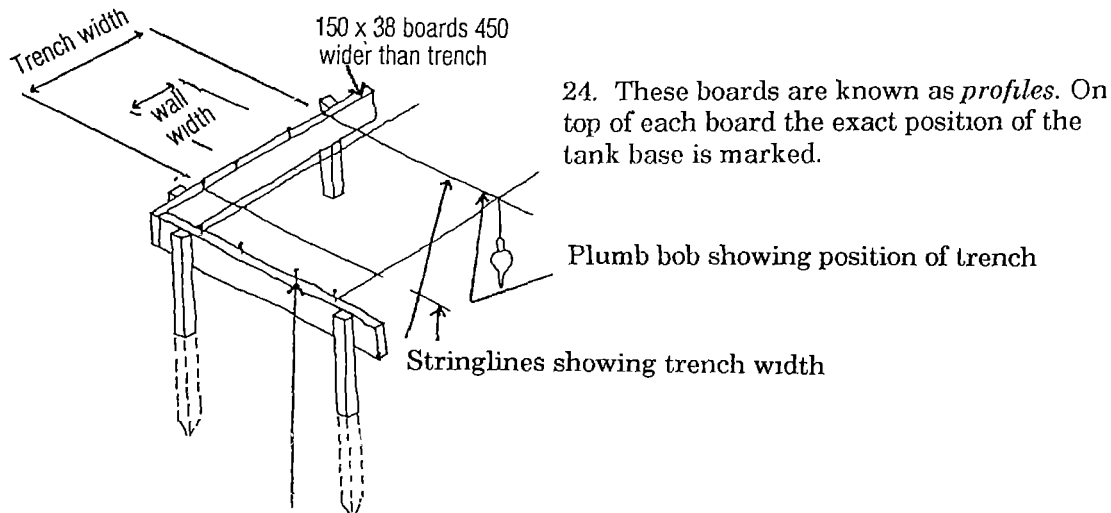

24. These boards are known as *profiles*. On top of each board the exact position of the tank base is marked.

Plumb bob showing position of trench

Stringlines showing trench width

Profile boards supported with pegs

25. To check that the profile boards are exactly at  $90^\circ$  to each other at the corners, a builder's square is used.

---

**Fakatokaga: Faitega Ote Tulaga Tane**

---

26. Mailuga foki ote laupapa tela e tuki ki pine e isi se fao e tuki kiei tela e tau ei te uka. Fakatele te uka iluga i fao katoa. Fua ki koonā keilōa me sukuea me ikai. E tau o pau ate fua tenei - koonā ki koonā.

27. Fakaoga te fua vai ke fakatalitonu me i uka e pau io me kesekese.

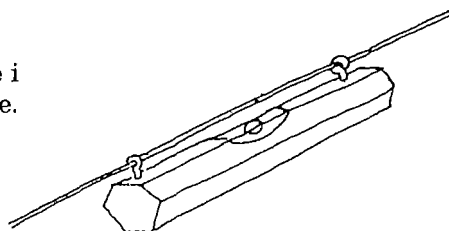

28. Sua aualā e mafai ō iloā te maluga o polofaela taki tasī kote fakaogaga ote vai. Ate vai e sala loa neia tona levolo tonu, tela e tau o utu kiloto a vai ki osi - paipa kae tuku kite maluga ote polofaela muamua ko fakatonu katoa ei kite maluga tena

---

## The Site & Making the Base

---

26. On top of the profile, partly drive in a nail, to which a string line is attached. Run the line around all 4 profiles. To check that the base is square, measure the diagonals. The measurement from corner to corner should be the same.

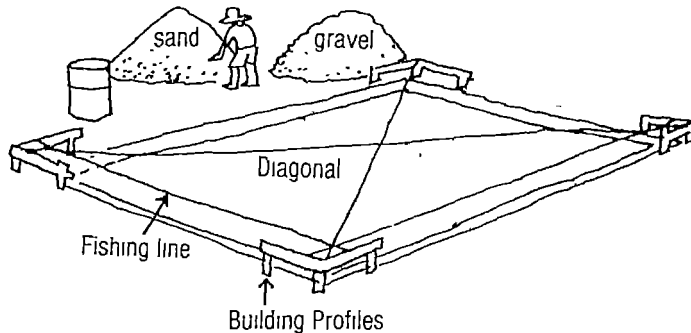

27. Using a line-level attached to the string line will indicate whether the profiles are set to the same height.

28. Another method that can be used to establish the height of each profile is the water level. As water finds its own level, by filling a suitable length of clear plastic hose pipe with water, it can be easily seen at what height the other profiles must be fixed to be level with the first one.

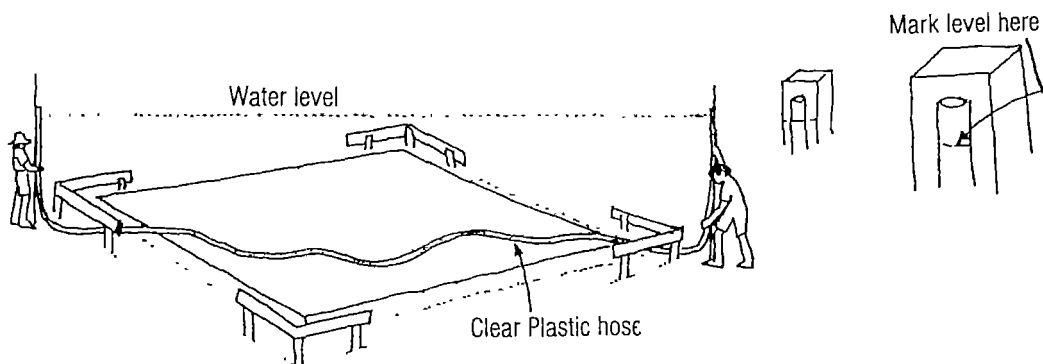

---

**Fakatokaga: Faitega Ote Tulaga Tane**

---

29. Fakaoga te fua vai o fakatōnu te lasi ote tulaga mailuga o uka ne tau ki lalo ite laukele. Tenei tonu ate maaka ka keli.

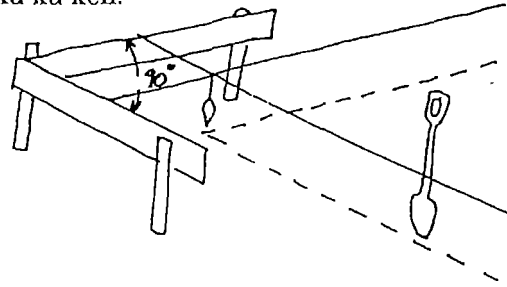

30. Keli te fakavae e tusa mote 300 mm lauefa kae 300 mm te poko. Katu ki lalo mai loto ote fakavae e tusa mote 150 mm.

31. Mo koga-koga ote laukele se makeke mo taofi te mafa ote tani ma fonu, keli kae fakafonu ki fatu mo kilikili.

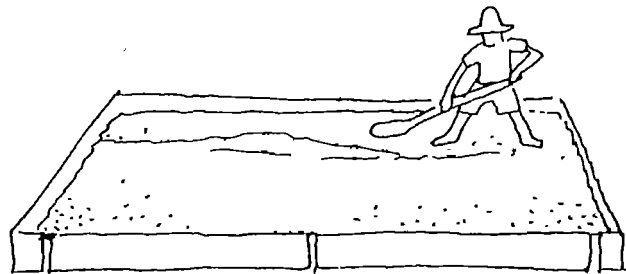



---

## The Site & Making the Base

---

29. To transfer the building line from the profile to the ground, suspend a plumb bob or use a spirit level. This shows exactly where the foundations for the base will have to be excavated.

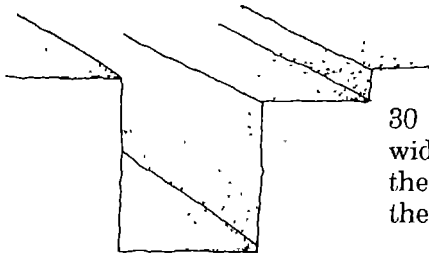

30. Excavate the foundation trench 300 mm wide and 300 mm deep. Remove any topsoil to the depth of 150 mm over the whole area of the base.

31. Where the ground may not be firm enough to support the weight of a full tank, extra ground will have to be excavated and replaced with hard fill such as broken stones, coral or gravel.

---

**Fakatokaga: Faitega Ote Tulaga Tane**

---

32. Mai se koga lei iloto ite tani, fakatoka se auala, ki tua ite koga e fakasali iei te tani. Fakamoe te paipa (500 mm te loa) kae 20 mm te fula (fakamoe se paipa mo taa te tani i e taimi).
33. Fakafonu a koga ote tulaga e aofia ei te fakavae kiluga i fatu mo one kise matolu e 120 mm. Tukituki fakalei ke moa e vagavaga koi tuai o fakatonutonu ko fao iei.
34. Mailuga ote 100 mm one, tuku te fiti fakapakeke. Lago te fiti ki fatu foliki kise maluga e 50 mm.
35. Koi tuai o ligi te palu sameni, onono fakalei kite i toka o mea e fai ei te galuega (tino galue mo mea faigaluega).

- 36 Te palu lei kote 1:2:4, 1 vaega ote sameni.  
2 vaega ate one, 4 vaega ote kilikili.

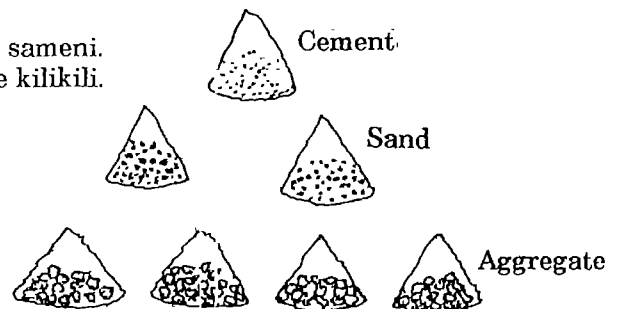

---

## The Site & Making the Base

---

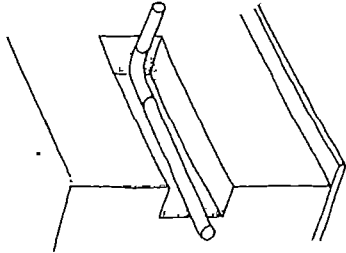

32. From a suitable point within the planned circular wall of the tank, prepare a shallow trench to the outside of the base to a point where outlet will discharge. Lay a length (about 300 mm) of 20 mm pipe with bend and upstand within the trench. (If a drain is provided this should be placed at the same time) See also clause 67

33. Allowing for the foundation strip, backfill the remaining area of base with suitable clean *hardcore* to a depth of 120 mm from the top. Compact this with a tamper. Spread sand over the base, rake it smooth and compact it using the hand tamper.

34. With the level of sand 100 mm below the top edge of the base, place steel wire reinforcing mesh (or bars) to cover the top of the base. Raise the mesh using small stones to a height of 50 mm above the sand.

35. Before mixing and placing concrete in the base and its foundation, check that you have available the quantities of materials, small tools and labour that you require.

36. A suitable mix for the concrete is 1:2:4 which means 1 part cement, 2 part of sand and 4 parts of aggregate (gravel). Previous experience with ferrocement tanks in the South Pacific where a leaner mix was used (e.g. one part cement to three parts sand) has shown a tendency for the tanks to leak and require frequent repair. For similar reasons a water proofing additive is also recommended (see para 17 above regarding this).

---

### Fakatokaga: Faitoga Ote Tulaga Tane

---

37. Kafai e manako latou kise palu lei kae malosi e tau o fua fakalei ate palu. Ate pokisi fua e tau o faite kae kote lasi kote 300 x 300 x 300 mo kau ei mo sau kiluga. Kote pokisi e 250 x 250 x 250 e mafai o sau ne se tino tokotasi.

38. Fakafonu ate pokisi fua kae ligi katoa kiluga ite laupapa palu. 1 pokisi sameni, 2 pokisi one, 4 pokisi kilikili.

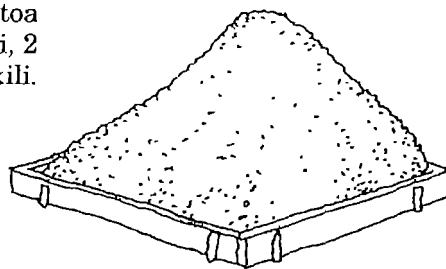

39. Mai se sevolo mo fakatau te palu koi tuai o faopopo te vai kiei. Ate vai e faopopo loa kote palu ke tai pili. Te mesini palu ka fesoasoani malosi kite faka folikiga ote taimi palu ei.

40. Ite taimi loa e toka palu ligi loa kiluga ite tulaga tela ko oti ne fakatoka. Ate fola ote tulaga e tau loa o pau io me levolo mote maluga o polofaela.

41. Ate one mote kilikili tela e fakaoga kiluga ite palu e tau o seai ne masima e piki kiei Kafai e fakaoga te one mai te tafa tai, tofatofa te one kise matolu e 100 mm ko fulu ei fakalei. Te leiga loa e tau te ua o fulu neia te masima tenei. Kise leva e tusa mote 2 masina.



---

## The Site & Making the Base

---

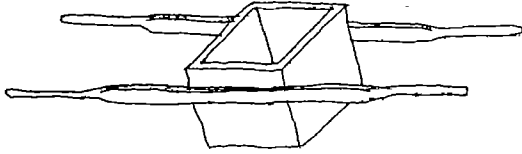

37 To produce a consistent and uniform mix all materials should be measured by volume. This can best be done by using a wooden gauge box measuring 300 x 300 x 300 mm and provided with handles for ease of lifting and carrying by 2 people.

38. Fill and empty the gauge box onto the mixing board, with 1 box of cement, 2 boxes of sand and 4 boxes of aggregate.

39. Using a shovel, the dry mix should be turned and mixed thoroughly before adding water. Add only enough water to form a thick pasty mix. A concrete mixer reduces the manual labour involved.

40. The concrete should be poured into the base and its foundation trench as soon as it is mixed. The wet concrete should be *tamped* down and smoothed off to the required height as measured down from the profiles.

41. It should be noted that sand and aggregate used for construction purposes must be clean and free of salt or other impurities. If beach sand or aggregate is used, spread it out to a depth of 100 mm and wash it thoroughly. Alternatively let rainwater *leach* out the salts for a period of at least 2 months before using.

---

**FAITEGA OTE TANE VAI: FAKA AOGAGA O PUSA**

---

42. Kafai e toka pusa, e tau o fakapiki kae sau kiluga ite tulaga o ia tela e tau o tu tonu ite kagaloto ote tulaga Fua mai tua ote tulaga kiloto ke maua lei ne koe te kagaloto.

43. Ono-ono kote mea ke tu tonu ate pusa tela ko - oti ne fakatu ite kagaloto ote tulaga.

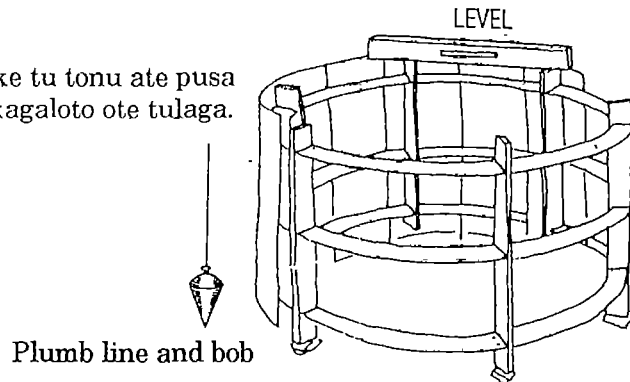

44. Ona la kote uke vaega pusa e fakaoga, e tau tatou o-ono-ono fakalei kiluga i pusa kola e tau o vali ki oela ite feitu kitua ke faigofie te tapalega.

45. Ona ko saisi o tane e kesekese, kafai e lasi te tani, ko iloa tonu ei me fia a lama ote uaea pa moa (me tasi ki saisi foliki, lua ki tani lasi) E isi fokı se uaea (1mm) e fakamiomıo ite foitino katoa ote tani.

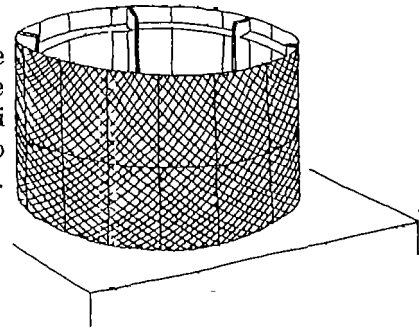

---

## MAKING THE TANKS: STANDARD FORMS

---

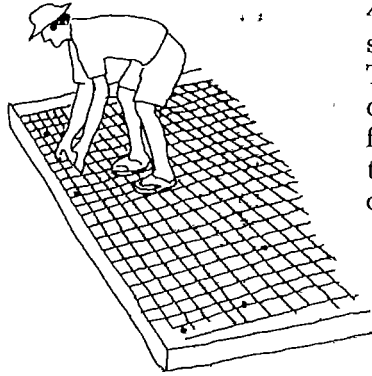

42. If standard forms are available, these should be assembled and moved into position. The formwork is then placed directly over the centre of the base. Check this by measuring from the outside edge of the square base to the formwork. It should be the same at the centres of each side.

43. With the formwork assembled and in position, check the *plumbness* and level. Use small stones to adjust the bottom of the formwork to make it perfectly straight.

44. Depending on the formwork material, the outside surface should be lightly oiled (i.e. timber and sheet metal). This helps to separate the formwork from the concrete (or mortar) once it has set. If formwork is oiled, all traces of oil should be removed from the face to be plastered.

45. Depending on tank size, a single or double layer of galvanised (chicken wire) woven wire mesh is wrapped around the formwork and tied in place with tie wires. Over the wire mesh a number of galvanised steel hoop wires are placed. Alternatively, a single length of wire is wrapped in a spiral.

---

## Faitega Ote Tane Vai: Fakaaogaga O Pusa

---

46. Uaea saisai, kamata atu mai lalo e tau a 15 mm te vavaga o latou. Ke oko loa kite 500 mm te maluga. Ite 900 mm te maluga ate vavaga ote uaea saisai ko fanaka kite 30 mm. Kiluga atu e 40 mm.

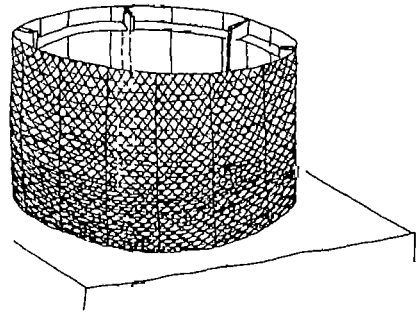

47. A uaea e tau o fakavavaa fakalei kae sai foki kiluga ie uaea pamoā ise aofaki 500 mm te vaa. E tau foki o mīo kote mea ke mau lei ate uaea.

48. Kafai ko toka katoa a mea kola ne manakogina ko tuai o palasita e tau nei o fulu ke ma sose lailaiga tela e nofo iluga ite koga kola ka palasita ei koe.

49. Te one e tau o fakama fakalei. E tau foki o fakaoga ate mea fakama one tela e 5mm te lasi ona pu. Tona uiga a fatu lasi ka se mafai o ulu tasi mo one.

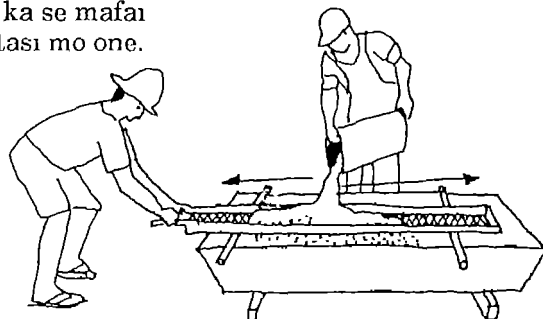



---

## Making the Tanks: Standard Forms

---

46. Starting from the bottom of the tank form, the steel hoops should be spaced 15 mm apart for the first 500 mm. From this point the spacing can be increased to 30 mm between hoops, until within 900 mm of the top of the tank. From here to the top the spacing increases to 40 mm. (The distances between adjacent hoops applies to the single wire spiral).

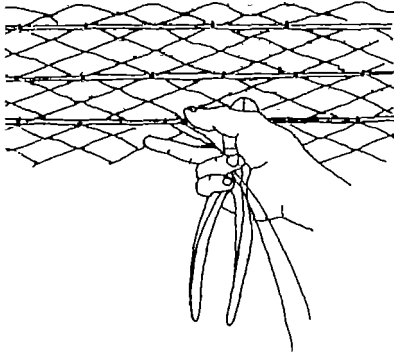

47. The hoops should be *parallel* to each other and tied to the woven mesh with tie wire at about 500 mm in the horizontal spacing. The hoops should be tight and the joins in the wire must be staggered. The hoops can be *kinked* to tighten them firmly in place.

48. With all the reinforcement in place the whole area should be thoroughly cleaned in preparation for trowelling mortar onto the tank form.

49. Sufficient clean sand should be sieved through a screen with an opening of not greater than 5 mm. This removes larger stones and other waste material.

---

## Faitega Ote Tane Vai: Fakaogaga O Pusa

---

50. A tulamu vai e tau o fakatu pili kite koga kafai lei te palu. Ate paketi e manakogina foki ite taimi tena kae ke maa.

51. A taga sameni kola se pakeke kae se silia atu ite tolu masina te leva e tau foki ke fakatupu pili kite koga tenei kae pulou kise pepa uli (tela seai se vai e oko kiei).

52. Ate laupapa lasi e tau 'o fakaoga mo palu ei te sameni: Sevolo, Alofilima, mea fakamania, ua mote laupapa kola e tau katoa ke toka mo fai te palasita.

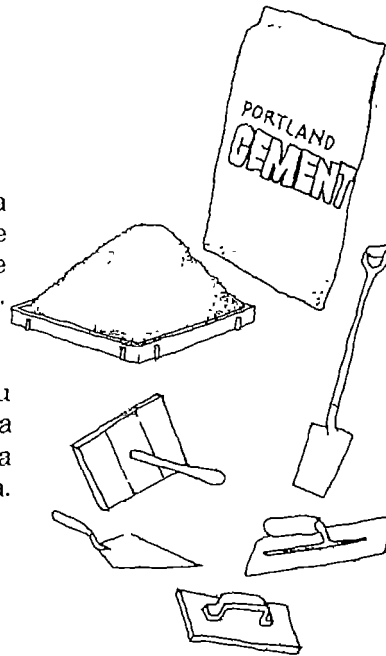

53. Ke maua se palu malosi, e tau o isi se pokisi fua. Kafai te fua ote palu e 1:2 tona uiga e 1 te pokisi sameni e 2 pokisi one kola e ligi kiluga ite laupapa palu.

54. Ate fakaputuga one mo sameni e tau o palupalu ke tau muamua koi tuai o ligi ne vai kiei. Fakapu ite kogaloto ko ligi ei te vai k.ei. Palupalu ke tau lei kae ono-ono loa kite taimi tela ko toka ei o fakaoga. Ka to uke te vai tona uiga kase lei kite palasita Fakaoga ate vailakau pela loa mote fai maiga nete kamupane ne faite neia te vailakau tenei.

---

## Making the Tanks: Standard Forms

---

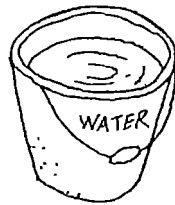
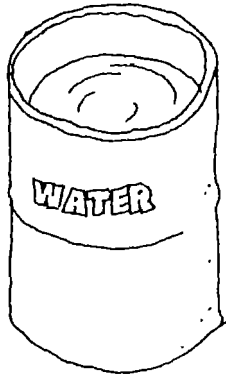

50. Drums of fresh, clean water should be placed near the mixing area. A clean bucket is also required for use when mixing the mortar.

51. Bags of *Portland cement*, which should be free of lumps and not more than 3 months old, should be stacked near the mixing area and covered with a waterproof sheet.

52. A large flat platform is required for mixing the mortar. Shovels, trowels, floats, a builder's hawk and timber straight-edges should be provided to mix, place and plaster the mortar onto the tank form.

53. To produce mortar of a consistent quality, a gauge box should be used. If a 1:2 mix is specified, then 1 levelled box of cement and 2 levelled boxes of sand are heaped onto the mixing board.

54. The heap of sand and cement should be dry mixed first. A hole is then made in the centre of the heap, and small amounts of water added to the mix. Continue turning the heap with shovels, adding water until the desired consistency is reached. The mortar should be firm and fatty. Too much water produces a runny mix and cannot be trowelled onto the form without falling off. If used, the waterproofing agent should be added during mixing or as instructed by the manufacturer.

---

**Faitega Ote Tane Vai: Fakaaogaga O Pusa**

---

55 Te tau māfaiga kote palu ke lei loa, e isi se fua ote palu tela e utu kiluga ite palu ke afa.

Te palu ka tuki kiluga ite potu fiti faka sefulu. Toe fakafonu te fua kae toe tuki foki kite potu fiti tena. Fakamasagi aka te fua ko fua ei te mafaoga ote palu.

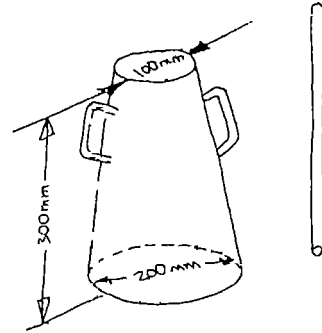

56. Te mafaoga tenei e tau o 75-85mm. Kafai e foliki ifo ite aofaki tena, faopopo te vai kiei. E tau o teesi katoa a palu ko mea ke maua ne tatou ate palu malosia kae lei

57. Kafai ko maua te fua tonu ote maofaga, kamata te palasita ite foitino katoa ote tani. E tau ate palu tenei o fakaoga ise leva e afa itula. Kafai ko to leva ka se lei ate palu. Ufi kise pepa io me pulou kise taga ate palu ke moa e malo vave.

---

## **Making the Tanks: Standard Forms**

---

55. To control the consistency of the mix, a *slump cone* should be used. A metal cone is placed on a flat board, and half filled with mortar. The mortar is rodded 10 times with a piece of steel rod. The cone is then filled and rodded again, before levelling off the cone. The cone is then lifted clear from the mortar and the slump is measured.

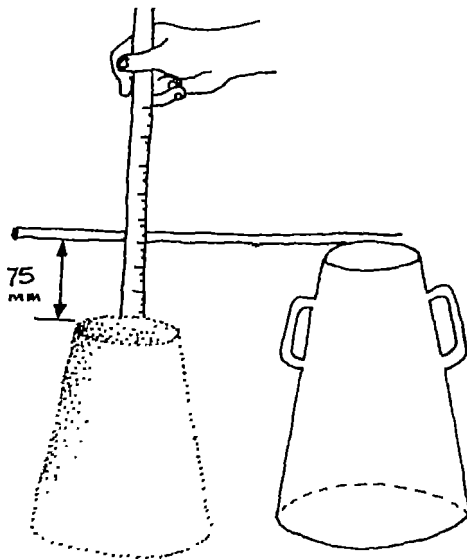

56. The measured slump should be between 75 to 85 mm. If less, add more water to the mix. If more, use less water. With practice it should not be necessary to test every mix particularly if consistent volumes of materials are used.

57. Once the correct slump has been obtained, commence plastering the mortar around the tank form. Use all the mortar within 1/2 hour of mixing, otherwise it will become unworkable. Place a wet sack over the pile of mixed mortar to prevent it from drying out too quickly.

---

**Faitega Ote Tane Vai: Fakaaogaga O Pusa**

---

58. Ate palu sameni e fakapiki kiluga ite foitino ote tani kite alofilima. Ate matolu ese matolu atu ite 15 mm Fakasoko katoa le foitino ote tani kite palu sameni.

59. Kafai te koosi muamua ko makeke, sele sele ko mea ke patupatu Mea nei kafai neia ke piki lei te sua palu sameni tela kote lua tami ote palasita Te matolu foki ote koosi tenei e 15mm.

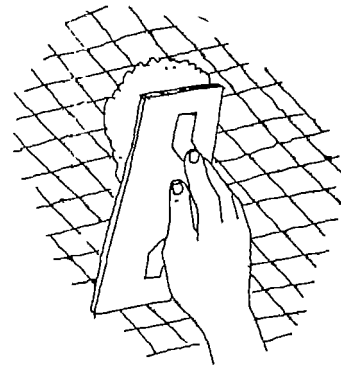

60. Fakatonu ate palasita kise lakau tonu. Ono-ono ki koga kola e ponapona, ko mea ke kati kite laupapa kae fakatonutonu Fakaaoga te alofilima o fakamaniania te foitino.

---

## **Making the Tanks: Standard Forms**

---

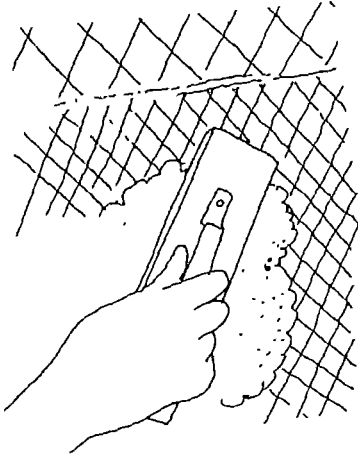

58. The mortar is applied by hand to the walls of the tank using a plasterer's steel float and builder's hawk. A layer of mortar not exceeding 15 mm is trowelled onto the formwork from the base of the tank upwards just covering the reinforcing wires. Continue on and around the tank, plastering on the first layer of mortar.

59. When the first layer of mortar has hardened sufficiently, scratch and roughen the surface. This provides a key for the second layer of mortar. Mix a new batch of mortar and plaster on a second layer. The thickness of this layer should be 15 mm.

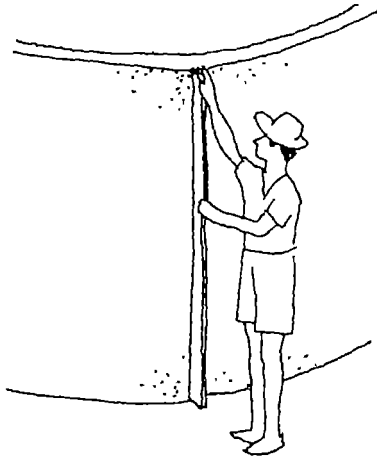

60. Using a straight edge, check the thickness of mortar between the bottom and top of the tank. Strike off any high spots. After the mortar has hardened slightly use the steel float to smooth the surface.

---

**Faitega Ote Tane Vai: Fakaaogaga O Pusa**

---

61. Ite 24 itula ko mafai ne tatou o tapale ate pusa. Fakaeteete moa e pakia te tani. Fulu fakalei ate pusa

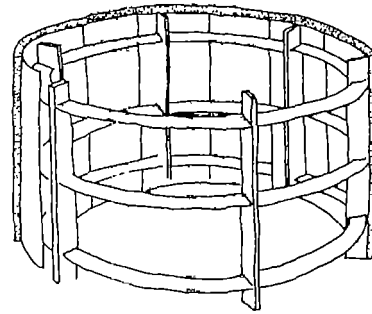

62. E 10 mm te matolu ote palasita e fakapiki mai lotu kae tuku loa ke malo fakalei koitua o toe palasita atu te sua 10-15mm Fakamaniania fakalei te palu sameni me ko te toe palasita fakaoti ei.

63. A te tani e tau ke ufi ki ne lautaga io me ki pepa uli kae ke siusiu kote mea ke moa e mapapa. E tau loa o faksiusiu a taga io me kote pepa uli tusa mote lua vaiaso. Laufutu e mafai foki o fakaaoga

64. E isi se palu sameni tela e fakatoka ke fai ei te soko ote foitino tani mote tulaga.

65. Te sua palu e fakatoka ke ligi kiloto mo fai te fola ote tani E tau foki o fai fakalei te soko tenei ke moa e mama.



---

## Making the Tanks: Standard Forms

---

61. After 24 hours the mould can be carefully stripped and removed from inside the tank. Care must be taken not to damage the wall in any way. Clean the mould for the next tank (in accordance with paragraph 44).

62. A 10 mm layer of mortar is then plastered around the inside of the tank and allowed to harden sufficiently before plastering on the fourth and final layer of 10 to 15 mm. This layer should be trowelled to a smooth finish.

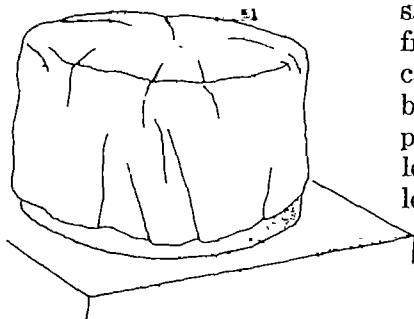

63. The tank should be covered with wet sacking or polythene sheeting to prevent it from drying out too quickly which would cause cracking in the walls. The walls should be kept damp by moistening under the polythene or by keeping the sacks damp for at least two weeks. Materials such as banana leaves can also be used.

64. A batch of mortar can be mixed and placed as a fillet at the junction of the base and outside of the wall.

65. Another batch is produced and placed inside the tank to form the floor 50 mm thick. Care should be taken to compact the mortar and form a watertight joint between the wall and floor of the tank.

---

**Faitega Ote Tane Vai: Fakaaogaga O Pusa**

---

66. Ate sameni mote vai e palu fakatası kote mea ke peeni kiei ate foitino  
ote tani

67 Ate paipa tela e fakasali ei te vai kitua e  
tau o 50 mm te maluga aka maite fola. Kafai  
e isi se paipa mo fulu, e tau o pau mote levolo  
ote fola

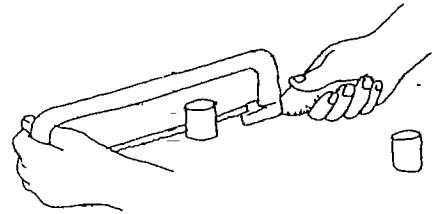

68. Kati se potu paipa 50 mm te loa, e tau mo fai te fakasali ki tua ote tani.  
Onono kite koga e mafaufau koe e tau o fakalave kiei, kati te tani mai lalo  
ote pono, faulu te paipa ko fakasameni iei. Ate mata ki tua ote paipa e tau o  
fakalave kise valavala

---

## **Making the Tanks: Standard Forms**

---

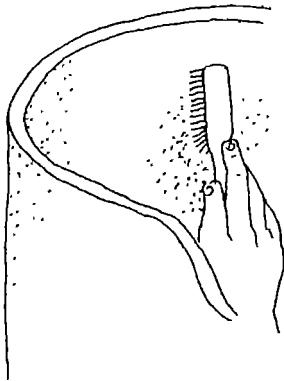

66. To effectively seal the tank, a 2-4 mm coat of *cement slurry* (cement and water), should be brushed or wiped over the internal and external surface of the tank.

67. The delivery pipe should extend 50 mm above the floor surface. If provided, the drain pipe (or washout) should be cut off flush with the floor.

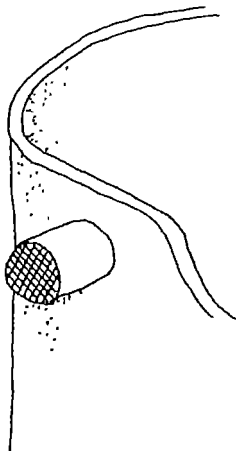

68. Cut a piece of 50 mm PVC pipe, long enough to be used as a tank overflow. Decide on the position for the overflow and cut a hole down from the top of the tank, through the tank wall. Provide the overflow level about 50 mm below the top of the wall. Carefully break out the cement and cut through the reinforcing. Fit the pipe, and cement it in place. The end of the overflow outside the tank should be screened with insect mesh.

---

## Faitega Ote Tane Vai: Fakaaogaga O Pusa

---

69. E taua tetausi ote tani vai fakalei ke moaa e mapaapa. Kite fakasiusiu aua te sameni e fano o maloo ko vagavaga iei. Fakasiusiu ise leva e lua vaiaso

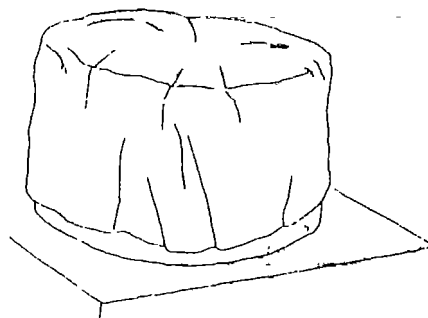

70. Kafai ko fakaoti te tani, ate pusa ote pono ka fakapiki kae saisai kiei uaea fakapakeke. Te palasita tela e palasita kiei e tusa mote 50 mm te matolu.
71. Ate pono e tau o tuite kogaloto kiluga kote mea ke malosı, kote vai foki ke moa e nofo loa ite pono, kae ke sali kilalo
72. Ate pusa foki ote pono e lago kiluga i pou laupapa kola e fakatu iloto ote tani. E isi ne pane kola e lago mai lalo ke fakatonutonu eı ate te maluga ote pusa.

---

## Making the Tanks: Standard Forms

---

69. An important part of ferrocement tank construction is in the curing of the tank. As cement dries out it shrinks and cracking occurs. It is essential that the wall and subsequently the roof be kept damp and shaded for at least two weeks.

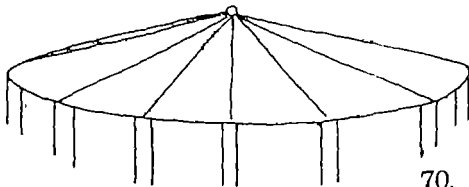

70. To complete the tank, the roof formwork is prepared and assembled, on which reinforcing mesh and wire are laid and plastered with 50 mm of mortar.

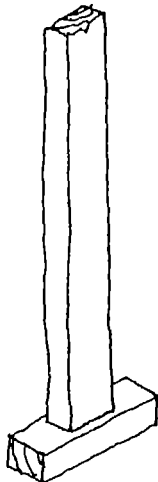

71. The shape of the roof should be domed, as this type of structure is stronger than a flat roof. It also sheds rainwater and dirt from the top of the tank.

72. The roof formwork is supported by using timber props placed inside the tank. Sliding wedges under the props are used to adjust height differences.

---

## Faitega Ote Tane Vai: Fakaaogaga O Pusa

---

73. E isi se puuga tela e fakapu ma'uga ite pono ote tani. Ate puuga fenei e tau loa kite lasi tela ka afi fakalei ei te tino kiloto ote tani i taimi e fulu ei io me e toe faite ei a mea masei ote tani.

74. Ate puuga foki tenei e tau o pono ki valavala ke moa kaiga mo manu e to kiloto. Te puuga foki tenei kafai mo mea e fakasali ei te vai kiloto.

75. Kafai ko oti lei ne palasita te pono ate soko ote foitino ote tani kiluga ite pono e tau o palasita fakalei. E tau foki o sai se loopu (20 mm) te lasi i kaugutu ote tani ko mea ke palasita ke maua te fakakauvae iluga ote pono

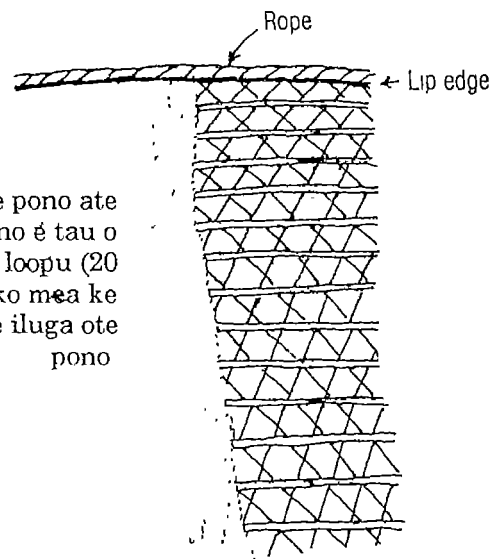

76. Te tani e tau o fakafonu fakasolosolo kote mafaga ke tufatufa iluga ite pui ote tani. E tusa mote lasi masani kae mafai ne te tani o oko loa ki tona malosiga. Nisi tani e pakia me ko to vave te fakafonuga ki ne vai uke. Ise taimi toetoe. Masaua, pui fakalei ate koga kitua ote tani kae fakasiusiu foki. Ate fakafonuga e tau o 300 mm ite aso kae 7 aso mai tua ote taimi ne lapale ei te pusa ote pono.

---

## **Making the Tanks: Standard Forms**

---

73. A *manhole* is cast into the top of the tank. The manhole should be large enough to allow a person to gain access into the tank, for inspection, cleaning and carrying out repairs.

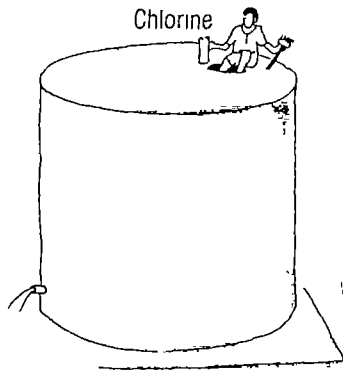

74. The manhole should be screened to prevent insects or dirt from gaining access to the tank. The opening is also used as the discharge point for the rainwater.

75. After the tank top has been plastered, the internal joint between the top of the tank and the roof should be completed. Externally a lip edge can be made by tying a length of 20 mm rope around the top edge of the tank. The rope is then tightened and levelled and mortar plastered around the rope. On setting, the rope is removed so leaving a straight edged joint.

76. The tank should be progressively filled over a number of days to allow the stresses within the tank walls to be distributed over the whole structure. **It takes approximately one month for the ferrocement to reach its full strength.** Many tanks fail because they have been filled with too much water too soon. Remember, keep the outside walls covered and damp, while adding no more than 300 mm per day to the water level of the tank. Filling should start 7 days after the removal of the roof formwork.

---

**FAITEGA OTE TANE VAI: FAKAOGAGA O NISI VAEGA PUSA**

---

77 Ate faifaiga tenei e se manakogina ne pusa. Te tani e faite kiluga loa ite uaea tela e saisai kae palasita fetu lua Kite sameni palu.

78 Niisi tani e fai kite uaea io me kote fiti fakapakeke tela e ofe ko fakapukupuku atu ei a uaea o paamoa kola ka saisai fakatasi ei mote sua uaea tela ka taofi noia te ua katoa

79 Mo vaega tani konei, ate faitega ote fakavae mote tulaga e pau loa mote faitega ote tani mua E isi se lakau e tuki ite kogaloto ote tulaga. Te loopu e sai kiluga ite potu lakau te loa tela e pau mote lasi ote tani vaevae nete D-2 ko maaka ei fakapukupuku.

80 E isi ne 12mm fiti e ofe kae sai kiluga ite fiti ote pusa. Mea nei ka fakamau fakalei nei a ate pusa fiti tenei

81. Ite fakaogaga o fiti konei, masaua e tau e loa o tonu kae se popo foki. Kafai e popo uaea pulasi aka, io me kuni ate popoga iluga ke ma fakalei.

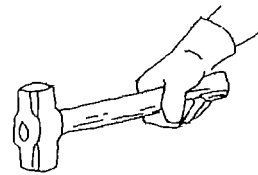



---

## MAKING THE TANK: FREE FORMS

---

77. This method of ferrocement tank construction does not require the use of moulds. The tanks are built by forming a framework, covered with a fabric of fine wire mesh, which is plastered from both sides with mortar.

78. The framework is constructed from 10 mm reinforced rods in the form of a cage, around which hoops of reinforcing rod are tied. Another method is to use welded mesh. The sheets are curved and tied together to form a cylinder and fine chicken mesh wire wrapped and fastened to it.

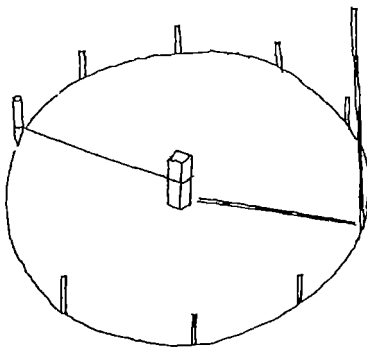

79. For free form tank construction, a solid foundation and base should be built as previously described. Depending on the diameter of the tank to be built, a stake is driven into the exact centre of the tank base. A peg is attached to a piece of rope, the length of which is equal to the radius of the tank  $D/2$ , is scribed around the stake and marks out a circle.

80. Around this circle, a number of 12 mm bent reinforcing *starter bars* are driven into the base. The vertical reinforcing rods are then wired onto the starter bars. This securely fixes the tank to the base.

81. In selecting and using reinforcing bars and rods for tank construction, make sure that they are straight and free of rust or scale. Chip and wire brush off any rust and straighten the rods before cutting and bending, or alternatively use galvanised bars.

---

**Faitega Ote Tane Vai: Fakaaogaga O Nisi Vaega Pusa**

---

82. Faulu e tolu fiti 25mm kiluga ite laupapa. Ofe kite tonuga o latou pela mote ata. Kaatiga o fiti e tau fakaoga te mea kati fiti, io me kote ekisoa.

83. Fua katoa te loa o fiti, fakaoga foki toegaga fiti ke se lasi te maumau o fiti ke se lasi te maumau o fiti. Kola e kati mo sai ate pusa fiti.

84. Ofe ate fiti ke pau mote fiti mai lalo ke fetau ite kogaloto ote tani. Te maofiga iluga ote tani e tau o pau mote maofega ote pono ote tani.

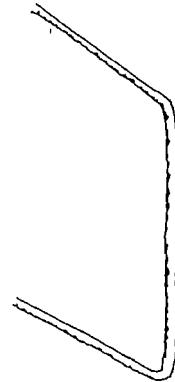

85. Te uaea tela e mio fakapukuuku e sai fakatasi mo fiti iluga pela foki mo lalo ote tani.

---

## Making the Tank: Free Forms

---



82. A simple jig can be made by fitting 3 short pieces of 25 mm rod into a thick board. Accurate bends and offsets can be reproduced on the bending table. Cutting of rods is best done by using compound action bolt cutters. Alternatively a hacksaw can be used.

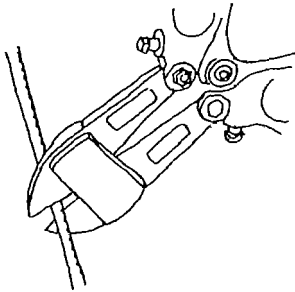

83. To minimise wastage of reinforcement, carefully measure all lengths and utilise any off-cuts in the fabrication of the form.

84. Bend the vertical rods to shape with the bottom pieces long enough to meet at the centre of the tank. The bends at the top of the tank should correspond to the angle of the tank top.

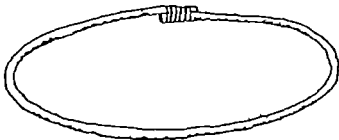

85. Circular hoops of different diameters or sizes should be formed and placed on the bottom and top of the tank. The reinforcing rods and hoops are then tied together using soft tie wire.

---

**Faitega Ote Tane Vai: Fakaaogaga O Nisi Vaega Pusa**

---

86. E isi ne uaea kola e olo mai tua ote tani ite vaa e se tau siliga atu ite 30 mm Sai fakalei a soko ke mau kise faau io me kote uaea fakamaumau.

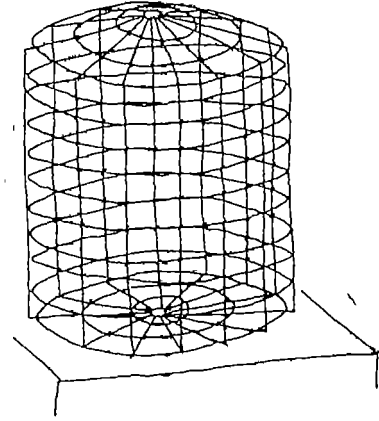

87. Ono-ono fakalei ki soko katoa ko mea ke tonu, fakaoga te fua vai ke tieki kiei ate pusa fiti tenei. Tenei foki te taimi e mafai ei o fai ne fakamafuliga koi tuai o fakamau te pusa.

88. Pui me sai e tolu laina o uaea pamoia kiluga ite pusa fiti kae sai ke mau. Ate uaea pamoia e fakaloa ki luga ke oko kite pusa ote pono. Kaati te koga ote uaea tela e fai mo fai te puuga e ulu ei te tino kiloto ite tani e pena foki te koga e faulu ei te potu paipa e fakasali ei te vai kitua.

89. Fai te palu pela mote palu tela ko oti ne fakailoa atu mua. Ate palu muamua e palasita feitu lua ote uaea. Tokotasi te tino e tu mailoto kae tasi e tu mai tua.

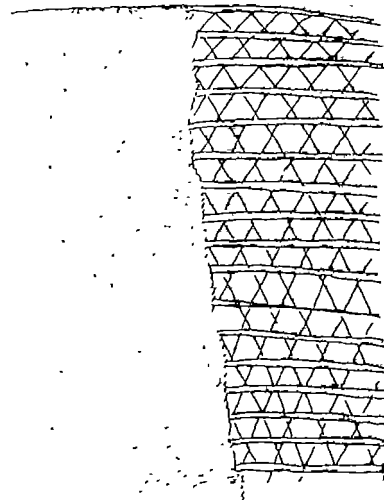

---

## **Making the Tank: Free Forms**

---

86. A number of hoops are formed and tied around the outside of the vertical form. These should be spaced no more than 300 mm apart (in the vertical). At each intersection securely wire the rods together using a pair of pliers and soft tie wire.

87. At this stage carefully check each joint and use a spirit level to check that the form is plumb and square. It is easier to make minor adjustments to the tank form before the wire mesh is fixed in position.

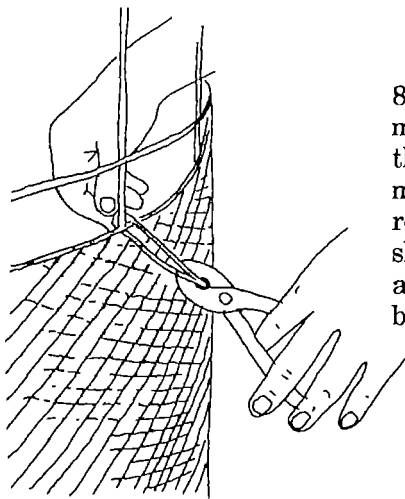

88. Wrap 2 to 3 layers of fine chicken wire mesh around the steel cage and secure it to the steel bars with soft tie wire. The wire mesh is extended up and over to cover the roof form. Carefully cut out the manhole shape and tank overflow. The manhole frame and overflow pipe are positioned and secured before plastering the tank.

89. Prepare and mix the mortar as previously described. The first layer should be plastered onto the wire mesh from both sides at the same time. One operator works from inside the tank while the other plasters on the mortar from the outside.

---

**Faitega Ote Tane Vai: Fakaaogaga O Nisi Vaega Pusa**

---

90. Ate pusa uaea tenei e tai vaivai. Te vaega muamua ote fakapikiga ote sameni e tau o se mole ite mea mana se piki iei te lua o fakapikiga.

91. Palasita fakalua iloto mo tua ote tani. Aumai te alofilma mo fakamaniania ate foino. Mai tua ote 24 itula, ate fola ote tani ko lei ite fakamaniania. Ate palu sameni ka tuku ifo io me tuku ki lotu ite puuga ote tani tela ne fakatoka mo ulu te tino. Te palu tenei ka tofa ki koga katoa ote tani (mulu) ko fakamaniania ei.

92. Kafai ko oti ufi te tani kise lautaga lasi kae siu ke oko kise leva e 7 aso. Kori tuai o fakafonu ki vai.

93. Ate foino kitua ote tani e mafai o peeni kise peeni kena, ke mafai neia o se miti te vela ote laa, tona uiga ka moko te vai iloto.

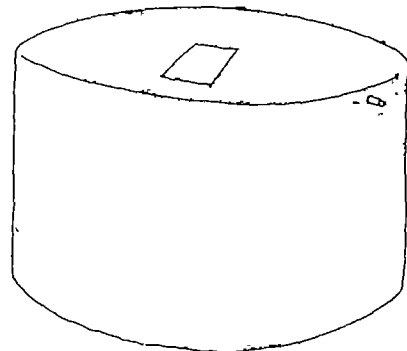

---

## **Making the Tank: Free Forms**

---

90. Initially the wired cage or form feels rather flimsy. Care must be taken not to dislodge the mortar during the first hour before it has set. The first layer should be left in a rough state to provide a key for the next layer.

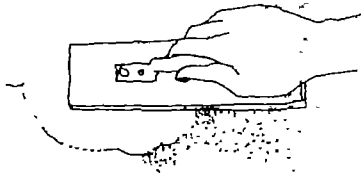

91. Plaster on a second layer to both the inside and outside of the tank. Using a steel float, trowel this to a smooth finish. After 24 hours the floor of the tank can be finished off. Mortar is passed through the manhole, spread over reinforcement to the required thickness and trowelled to a smooth finish.

92. When complete, cover the tank with wet sacking and allow it to cure for **at least 7 days** before gradually filling it with water and keep the outside of the tank covered with wet sacking during the gradual filling process.

93. With the tank completed, the outside surface can be painted white as this will reflect the heat away from the tank, cooling the stored water. Use a vinyl base paint or whitewash.

---

**TAUSIGA OTE VAI KE MAU**

---

94 E tau tatou o tausi fakalei te vai tela e maua ite vaiua

95 Ate vaiua e tau o fakasali kiloto ite tani  
tela e isi se fakama e ufi te puuga ote tani  
Ko kaiga kola e lave iloto ite fakama tenei e  
tau katoa o teu katea i taimi katoa

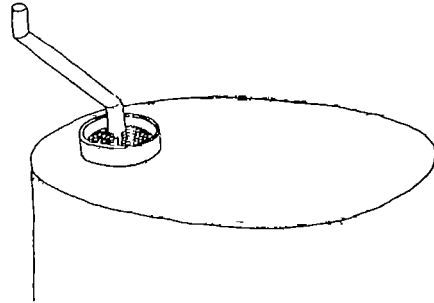

96. Mo tuafale lasi ikoga kola se lasi te to sale o vaiua, ate kaiga e uke ka  
maua atu ite taimi tela e toe to ei te ua. Te vai la tenei ka sali atu kiloto ite  
tani tela ka fakamasei ei neia te vai.

97. Kafai ese mafai ne tatou o teu ke ma alaavai mo te valavala ote tani, i  
lasiga o taimi, tona uiga e tau mo tatou o fulu fakalei te tani. Mai konei, e  
mafai foki ne tatou o fesokotaki kite kau ote tuma ke fakailoa mai te aofaki o  
vailakau e tau o pei kiloto ite taimi e fulu ei.

98. Vaiua io me ko vai e maua mai ite tuafale lau, e masani o manogi  
palapala kae lanu sega foki. Kote fakamaga ote vai tenei e tau o faite te  
fakama, mai pulu, lefu mo one iei.



---

## KEEPING WATER CLEAN

---

94. Every effort should be made to safeguard and protect the stored rainfall. Gutters should be cleaned regularly, especially where shaded by trees.

95. The rainwater downpipe should discharge into the tank over a screen installed in the manhole. Rubbish collected on the screen should be cleared away regularly. As an alternate a large mesh screen may be placed at the top of the downpipe where it leaves the gutter and a fine mesh screen can be placed where the water leaves the downpipe and enters the tank.

96. For large roofs in areas of infrequent rainfall, the accumulated dirt and rubbish on the roof presents a problem. With the first rains, the dirty water enters the tank and could contaminate the supply.

97. If the gutters and tank screen are not cleaned regularly it may become necessary to clean out the tank. In such an instance, advice should be sought from the health authorities as to the type and quantity of chemical to be used in the cleaning process (chlorine is widely available and commonly used).

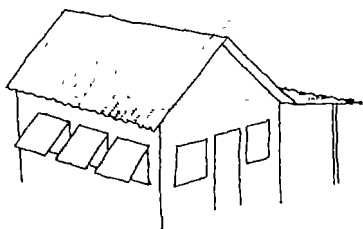

98. Rainwater collected from thatched roofs may sometimes smell of decomposed leaves and have a yellowish or tea colour. To clean the water, it can be filtered through crushed charcoal, coconut fibre or sand. For these reasons local attitudes and tradition play an important part in the use, or otherwise, of such run off.

---

## Tausiga Ote Vai Ke Maa

---

99. Alaavai kola e faite mai i pamupu e mafai foki e fakaoga mo fakatali te vaiua mai te tuafale lau. Alaavai konei ka sai ki iuga i fuafua ote fale. Masaua ke sifo lei alaavai konei.

100. Ate vai la tenei e fakasali ki lotu ise tulamu tela ko oti ne fakatoka ki luga i laukafa mo laukaka kise maluga 500 mm. E pela mo tani sameni pukupuku konei, ate mea fakama e faite mai luga ote tani kite lasi tena e fakaasi atu. I lalo ote tulamu e isi se uaea laga tela e taofi neia a pulu io me ko laukaka me mato ki lotu ite tani.

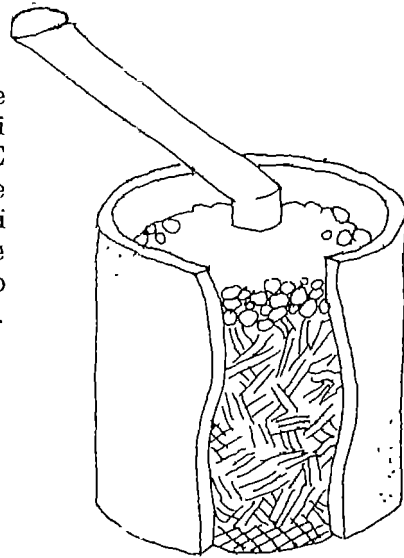

101. Te fakatokaga ote fakama, fakavaia pulu kise leva e 2-3 aso. Tapale a pulu kae toe faka vai kise 3 aso kote mea loa kote lanu ote pulu ko matafi. A pulu ma konei e fakatoka ki lotu ite tulamu (A pulu iloto ite tulamu e sui sale mai te 3-4 masina) E tau ko aasi te tulaga o pulu pela foki te tulaga ote vai. Sui a pulu mafai te lanu ote vai ko mafuli.

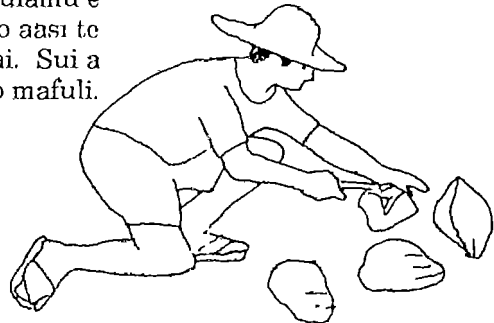

---

## Keeping Water Clean

---

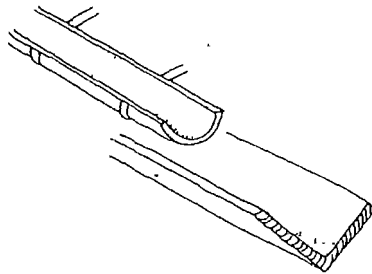

99. Gutters made from split bamboo or V shaped boards can be used to collect the rainwater from thatched roofs. The gutters are secured by straps or wires to the rafter ends, providing sufficient fall towards the outlet to drain the gutters.

100. The rainwater downpipe discharges into a filter drum that is filled to a height of 500 mm with compacted coconut fibre. For ferrocement tanks the filter basket can be built into the top of the tank to the dimensions shown. At the bottom of the drum a wire mesh screen prevents the fibre from falling into the tank.

101. To prepare the filter material, soak coconut husks in water for 2-3 days. Shred the fibre from the husks and soak it for a further 3 days until all the dirt and colour has been washed out of the fibres. The cleaned fibres are packed into the filter drum. Generally the fibre in the drum has to be discarded and replaced every 3-4 months.

It is important to regularly check the condition of the filter and the quality of the water. If the fibre deteriorates or the water becomes discoloured, clean out the filter and repack it with new clean coconut fibres.

---

## Tausiꝯa Ote Vai Ke Maa

---

102. Se tani fiti, io me se tulumu mago e mafai foki o fakaoga mo mafai ate tani e tau o fakafonu kiluga ise 50 mm kilikili fliki (sa'isa e pine) kō laukaka mo pulu e fao kiluga ise 450 mm mailuga o kilikili. Ate vai laulai e ulu i lotu i pulu kona, ko kaiga lasi e mafai o lave iei.

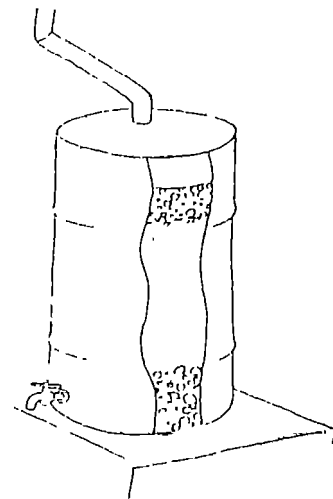

---

## Keeping Water Clean

---

102. As an alternative, a metal tank, or an old, clean oil drum, could also be used as a filter. The bottom of the drum should be filled to a depth of 50 mm with pea-sized gravel, fibre or charcoal and is packed into a depth of 450 mm above the gravel, and a 50 mm layer of coarse gravel is spread over the top. The dirty water will percolate down through the filter, with larger particles being trapped in the fibres. When the filter becomes clogged it has to be cleaned out and repacked with new materials.

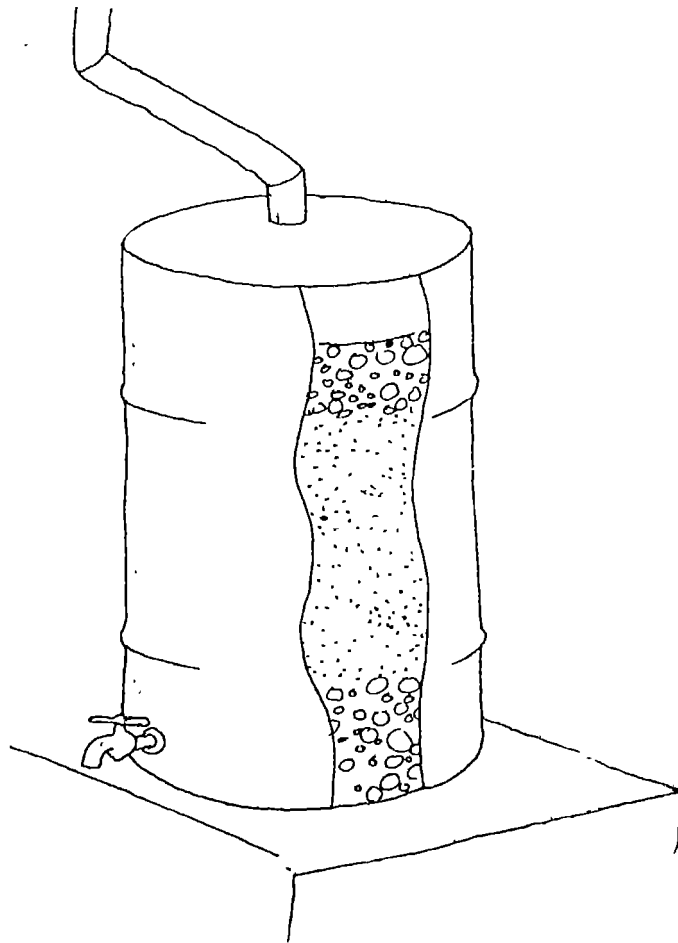

---

**TAUSIGA O TANE MOTE FAKALEIGA O MEA PAKIA**

---

103. Kafai te tani e mama e tau loa o pono, niisi koga mama e mafai loa o lei ia latou. A puuga foliki e mafai o pono, manafai e palu ne koe ate sameni mote vai ko nini ei kiluga ite tani.

104. Mo koga mapa ote tani, tipi kitua a sameni ite koga tena ko fakafonu kiluga ite vailakau e igoa kite epoxy resin.

105. Kafai te tani e mafafa, tipi fakalei te koga tena kae tapale potu sameni ko fai fakalei ei ate uaea. Fakatoka se palu palasita, ko palasita ei te koga tena (1.2 sameni, one te palu).

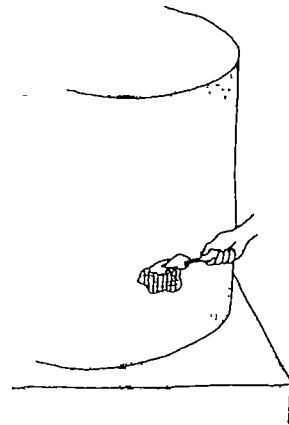

106. Mo tani kola kose toe mafai o fai fakalei, pui se uaea fou matua ko toe palasita ei.

---

## REPAIRS AND MAINTENANCE

---

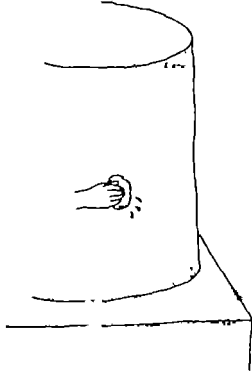

103. If a tank leaks it should be repaired, but it should be noted that some leaks are self-sealing.

Very small porous holes can be sealed by mixing cement and water and rubbing the mixture into the holes with a piece of sacking.

104. For minor cracks caused by impact, first cut out along the line of the crack inside the tank with a cold chisel or scraper and fill the crack with cement mortar of the same mix as the original. (*Epoxy resin* can also be used).

105. If the ferrocement has surface damage causing the cement to shatter, first clean around the damaged area and remove any loose material. Straighten any bent reinforcement and, using a 1:2 cement sand, mix plaster over the spot. Large holes may also be fitted with a patch of mesh prior to plastering (this patch should be wired into existing reinforcement at the edges of the hole).

106. For tanks that are beyond repair, consideration should be given to using the old tank as existing formwork for a new one. Clean the external face properly to remove algae etc., and roughen the surface, then wrap wire mesh around the old tank and plaster mortar over it, thereby forming a new tank.

---

**Tausiga O Tane Mote Fakaleiga O Mea Pakia**

---

107. Alaapaipa ote tani ke ufi io me fai fakalei ki samcni. E fesoasoani ki mafai e fonu te paketi i vai kae tautau mai iei

108. Kote tausiga ote vai moa e maumau, ate tani e tau o isi sena loka.

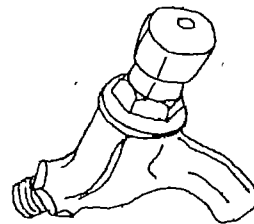
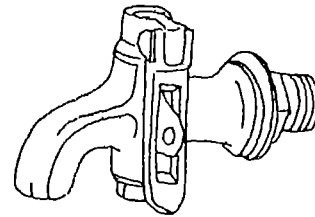

109. Te gataga ote vai e masani sale o qiloa mafai e asi sale.



---

## **Repairs and Maintenance**

---

107. Pipework from the tank should be well protected. Encase the pipes in concrete or secure the pipe to a post. This prevents buckets being hung over the pipe for filling which could cause the pipe to fracture.

108. To prevent wastage of water and to safeguard the supply, the tank should be fitted, where possible, with either a lockable tap or a spring loaded one.

109. Water depth is usually monitored at intervals by inspection.

---

## Tausiga O Tane Mote Fakaisiga O Mea Pakia

---

110 Kafa te palanuga mo mea katoa ko toka, ko mafai ne tatou.

- galue te lasi ote tani
- fakatokaga te logi mo mea efai ei e tani
- te koga ka tu ei te tani
- faiga ote tulaga tani, mo paipa e lu lei
- te fakatuuga ote pusa mote aisaga o uaea
- palasitaga ote tani
- fakasiusiuga ote tani
- te fakaotiga ote pono
- fakaotiga o alaapaipa
- teuga fakalei o tafatafa ote tani

111 Pela mote lasiga o galuega. Te lei e vau mote masani. Te faitega otre tani, io me kote lei ole tani, e manakogina, ate fakatoga ite faitega, maaka, faiga ote palu sameni. Kafa ko numi koe, fesili kise tino eiloa lei neia te mea nei.

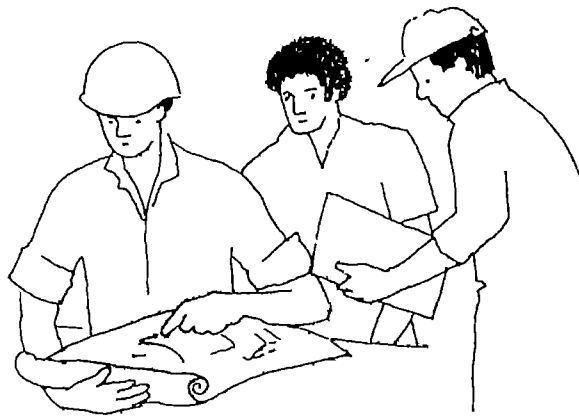

---

## **Repairs and Maintenance**

---

110. With careful planning and having all the necessary materials and tools readily available a systematic approach should be made to:

- calculating and determining the size of the tank
- estimating the quantities of material required
- determining the exact location of the tank
- preparing the foundations and marking out tank position
- building the tank base and installing pipework
- erecting the formwork, or fabricating the steel framework
- placing and securing the wire mesh
- plastering on the mortar
- curing the tank
- completing the formwork and plastering the top
- completing the pipework
- carefully checking the tank and painting it
- cleaning up the surrounding area

**As with most jobs, proficiency comes with practice. To build a good ferrocement tank requires a methodical approach in setting out, fabrication, and application of mortar. These skills are not difficult to master.**

**If in doubt, always seek advice or assistance.**





---

## GLOSSARY

---

Note: Those words in *italics* are included in this glossary.

absorb	-	suck up or drawn into
batch	-	a volume/measure of mortar or concrete
builder's hawk	-	small flat board with handle in the middle
catchment	-	area in which rainwater collects
cement slurry	-	a runny paste of cement and water only
consumption	-	amount of water used
epoxy resin	-	two part mix, that has great strength on hardening
gas generation	-	bubbling of gas in cement mortar
fabricate	-	make, build or construct
hardcore	-	rocks, stones, concrete or similar
kilopascal	-	unit of measurement for pressure
kinked	-	bent or adjusted
leach	-	wash out
manhole	-	frame or opening into tank
parallel	-	equal spacing
plumbness	-	verticality
porous	-	allows water to seep through
Portland cement	-	used for general construction purposes
profile	-	outline of the height and shape of the base
slumpcone	-	truncated cylinder
starter bars	-	angled or bent steel rods
strike off	-	knock or level off
tamped	-	packed or forced down





