

Library
IRC International Water
and Sanitation Centre
Tel.: +31 70 30 689 80
Fax: +31 70 35 899 64

CONSTRUCTION OF WIRE - REINFORCED - CEMENT MORTAR TANKS

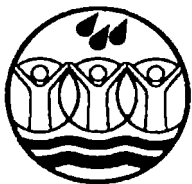
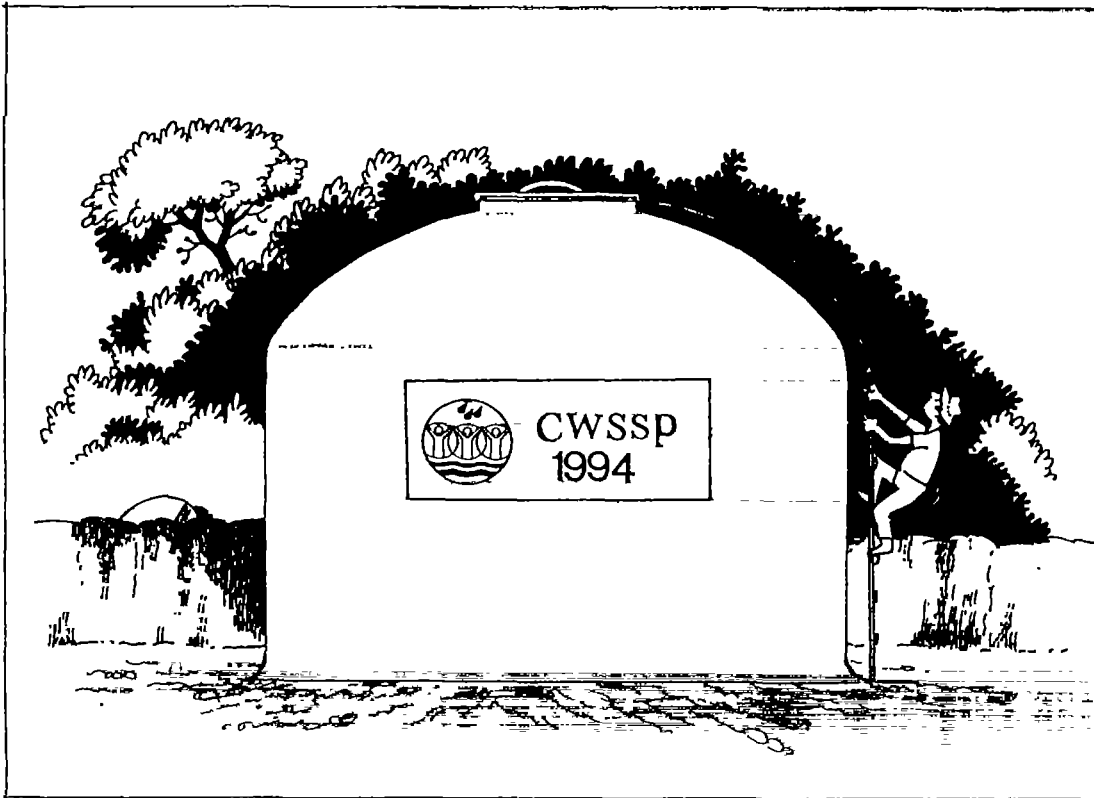

COMMUNITY WATER SUPPLY & SANITATION PROJECT

Ministry of Housing, Construction & Public Utilities
Sethsiripaya
Sri Jayawardenapura Kotte
Battaramulla

NEIL HERATH
February 1995

CONSTRUCTION OF WIRE-REINFORCED-CEMENT MORTAR TANKS

1. CONSTRUCTION MATERIAL

A small assortment of construction material are required for the Construction of these tanks.

- Ordinary portland cement
- River sand
- 1/2" - 3/4" metal
- Tor steel reinforcement (10mm)
- 6.3mm Mild steel
- G.I. Straight wire
- G.I. Woven mesh (no. 4)

1.1 SAND

The ideal type of sand to be used to mix the mortar is moderately coarse river sand with uniform grain structure. Finer sand produces weaker mortar and results in shrinkage cracking.

It is best to use sand with a grading of coarse and fine particles free from dirt. It would produce a good workable mortar.

1.2 MORTAR MIX

To make a satisfactory workable mortar mix it is necessary that the sand and cement are mixed in appropriate proportions. Stronger mixes (mixes with more cement) produces more workable mortar, increases its final strength, but will lead to greater risks with wider shrinkage cracks.

Mortar mix of one part cement to three parts sand (1:3) is suitable for construction of these tanks.

1.3 WATER - CEMENT RATIO

Mixes with least water produces strong mortar. However, workability of such dry mortar is poor. On the other hand mixes with too much water will be difficult to work on to the mesh, as it would start falling off.

A water cement ratio of 0.5:1 (water : cement, by weight) recommended for ferrocement construction is ideally situated for the mortar mixes used in the construction of wire-reinforced-cement mortar tanks too.

LIBRARY IRC
PO Box 93190, 2509 AD THE HAGUE
Tel.: +31 70 30 689 80
Fax: +31 70 35 899 64
BARCODE: 14 267
LO: 217 9500

1.4 MIXING OF MORTAR

It is important that sand, cement and water for mixing mortar are gauged accurately to obtain a good workable mix. Batching of material for mortar mixes shall be by volume. It is recommended that a gauge box of Volume 1.25 cuft. (Volume of one bag of cement 50Kg) is used to gauge the sand for mixing. The internal dimensions of such a box may be 12" x 12" x 15". It will be useful to have another gauge box to half this Volume or to make the same gauge box with provision to gauge half its volume.

In mixing mortar the following procedure may be followed.

- Select a hard flat platform for mixing the mortar.
- Using the gauge box to measure the required quantity of sand onto the platform.
- Spread the sand evenly on the platform.
- Measure the appropriate quantity of cement
- Spread the cement evenly on the sand.
- Mix the sand & cement thoroughly in its dry form.
- Add water to the mix in small quantities and mix thoroughly until a good homogeneous mortar mix is formed.

Mortar once mixed should be used immediately. It is recommended that the heap of mixed mortar is always kept covered to avoid drying up. No mortar older than 45 minutes is to be used under any circumstances.

It is very important that due consideration is given to factors such as the nature of work involved, number of Artisans employed in deciding the quantity of mortar to be mixed at any one time, so that the above conditions could be met.

1.5 STEEL REINFORCEMENT

Steel reinforcement for the tank base is usually of Tor steel. 6. mm diameter mild steel is used as vertical skeletal steel continuing from base to crown. The main reinforcement of the tank is the G.I. straight wire fixed spirally from base to crown. The bottom third of the tank wall is subject to the greatest loading due to water pressure. To withstand this higher loading in larger tanks, this area has to be reinforced slightly more. The additional reinforcement required is shown in the drawings.

The G.I. wire mesh used in the construction serves three main purposes. Firstly it acts as a formwork backing for application of cement mortar. Secondly it prevents, the cement from cracking due to shrinkage. Thirdly it helps to keep the steel cage adequately stiff during applications of mortar.

Selection of a particular type of mesh in the construction has to be made in consideration of the above requirements. Expanded metal mesh is the ideal type. However, it is not available locally and hence the woven mesh which is manufactured locally is being used instead.

Given below are some of the important areas where special attention is needed in fixing of reinforcements.

- Anchoring of the skeletal steel of wall into the base. The length of the anchor should be 40d. (40 x diameter of rods)
- Provision of a minimum anchor length of 200mm of the wire mesh into the base concrete.
- Vertical overlaps of wire mesh to be 200mm and the horizontal overlaps to be atleast 50mm.
- Lap length of the straight wire reinforcement to be atleast 300mm.
- All free ends of the binding wire used for fixing steel in place are to be on the inside face in case of the walls and on the outside in the case of the cupola roof. Care shall be taken to flatten the wire ends against the mesh.

2. SEQUENCE OF CONSTRUCTION

- Selection of site
- Excavation
- Positioning of pipework
- Screed concrete
- Fixing reinforcement for the floor slab
- Floor concreting.
- Reinforcement for the wall
- Application of cement mortar to outside of wall
- Application of cement mortar to inside of wall
- Floor rendering
- Reinforcement for the roof cupola
- Application of cement mortar to outside of cupola
- Application of cement mortar to soffit of cupola
- Completion of the access opening (upstand ring beam)
- Installation of the overflow and vent pipe.
- Installation of ladder and cover for access opening
- Painting
- Installation of valves and construction of valve chambers
- Landscaping

3. CONSTRUCTION PROCEDURE

3.1 SELECTION OF SITE

WRCM tanks are generally constructed above ground level. The excavation involved is minimal. Due to its thin walls WRCM tanks could easily be affected by direct impact. Hence, It is advisable to construct these tanks away from locations where there is a potential danger from rolling or moving objects such as rock boulders, tree trunks, branches etc.

Due to the lightness of the structures, these could be sited conveniently in such locations where other comparatively heavier structure such as rubble masonry or reinforced concrete tanks cannot be erected. However, the bearing soil should be sufficiently firm so that there is no possibility of differential settlement or lateral movement or sliding.

3.2 EXCAVATION

The only buried section of the WRCM tank being the concrete base the extent of excavation involved is minimal. However, the top soil containing humus and other organic matter should be completely removed and the loose top layer of soil removed exposing the subgrade which should be firm. The excavated material other than the top soil should be disposed off at tips located away from the site. The removed top soil however could be re-used to stabilize and turf the exposed excavated surfaces and slopes adjacent to the structure after completion as protection against possible erosion.

After levelling the exposed sub-grade the outline of the circular base of the tank is marked on the ground using a rope. The excavation for the foundation is 150mm deep unless specified otherwise. Where the soil is firm care should be taken to keep the edge of the excavation straight and true to line. In certain types of soils it may be necessary to use some form of improvised formwork to protect the sides of the excavation from falling in. But the need to do so will be rarely felt, as the depth involved is very small.



All pipe outlets of WRCM tanks are laid to pass through the floor slab. Due to its relatively thin walls there is a possibility of leaks along the pipe surface if such outlets are provided through the wall, as is done in tanks built in the traditional way.

3.3 POSITIONING OF PIPE WORK

Only two pipe outlets viz. common scour/main outlet and the overflow are provided in these tanks, both through the floor slab unless detailed otherwise. These pipes shall be laid in trenches excavated below the floor slab.

PVC pipes and specials are used for the two outlets. To prevent leaks along the length of the pipe the pipes are to be provided with pvc puddle collars at the section passing through the concrete base. After the pipes are laid the trenches are filled with compacted concrete 1:3:6 (20mm) embedding the pipes.

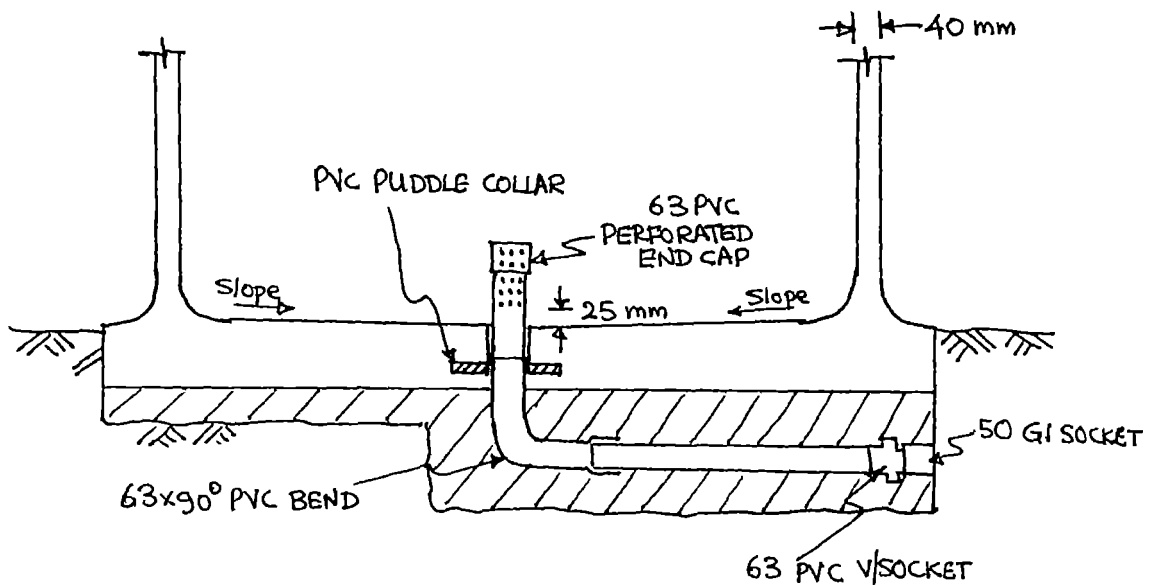

PIPE POSITIONING DETAIL

It is advantageous to provide a GI sockets to the end of the outlets properly anchored in the concrete so as to prevent any danger to the pipe. Such damages would be due to differential settlement or torque when other pipe components such as valves etc. are fixed.

The common outlet is positioned about the centre of the floor. This will enable easy and effective washing & cleaning of the tank. The overflow outlet however shall be positioned closer to the wall so that the upstand pipe could be supported from the wall if necessary.

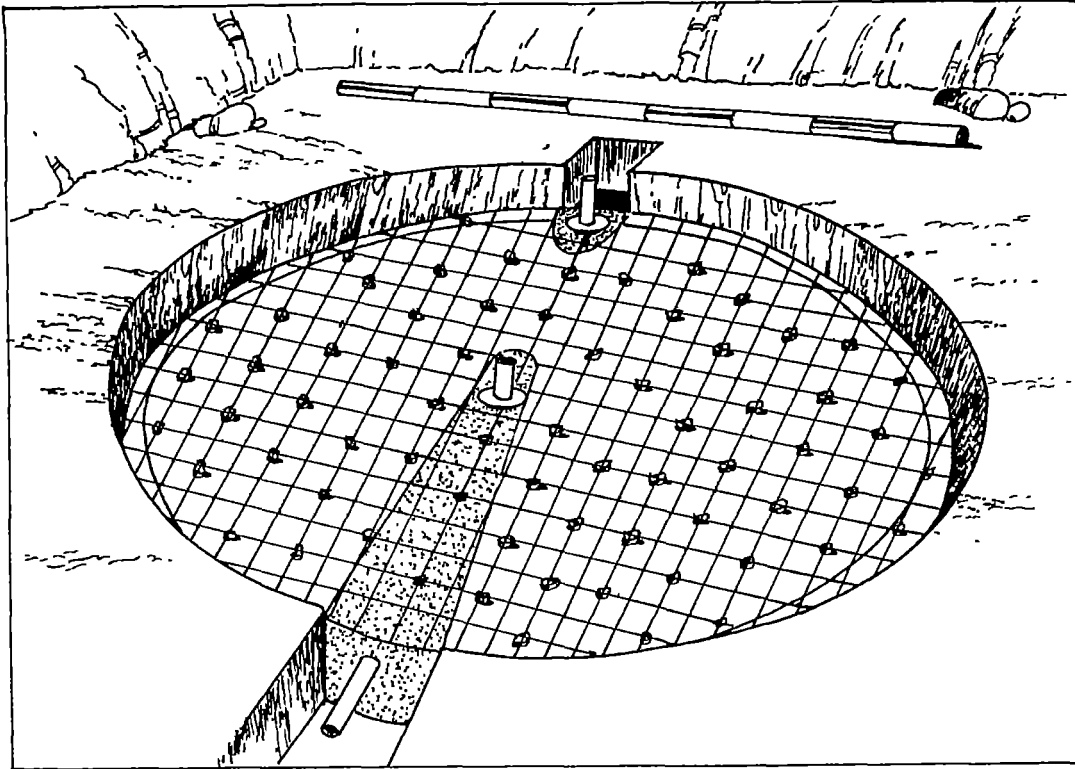

3.4 SCREED CONCRETE

A screed concrete 1:3:6 (20mm) of 50mm thickness is usually placed in the excavation for the foundation in all tanks before the floor slab is constructed. The screed concrete can be eliminated only in those cases where the floor is mass concrete.

It is necessary to level the surface of the screed adequately using a hand ram and float.

3.5 FIXING REINFORCEMENT FOR THE FLOOR SLAB

Reinforcement for the floor slab is nominal and is usually of 10mm Tor steel placed either way at the specified spacing indicated in the drawings. Clear cover to the reinforcement is 40mm. It is important to use proper cement spacer blocks with embedded binding wire strands for tying them securely to the mesh to prevent movement during concreting.

At this point it is necessary to mark the perimeter of the wall on the floor reinforcement enabling assembly of wall reinforcement. For this purpose a circular ring having a diameter of $(D+W)$ is constructed out of 6 mm steel bar, where 'D' is the internal diameter and 'W' is the wall thickness. This is placed centrally to the floor, and securely tied, on the floor reinforcement mesh already assembled in place.

As discussed in section 1.5 the vertical skeletal of 6 mm (M.S) and the G.I woven mesh have to be adequately embedded in the floor to strengthen the wall to floor joint.

The mesh is usually available in 1 meter wide rolls. A length of the circular wall plus the recommended horizontal lap length of 200 mm is cut from this roll. It is then bent to 'L' shape along its longer side, the shorter arm of the 'L' being 150 mm. It will be necessary to split the bent length of the mesh at shorter intervals to facilitate bending it to the required curvature. The 6 mm vertical skeletal steel is then assembled at specified spacing along the same perimeter of the mesh. It is possible to use shorter lengths of 6 mm M.S. rods as starters only. However, as indicated in the drawings it is recommended that the full lengths are used to avoid unnecessary lappings. The reinforcement placement is now complete for receiving the concrete in the floor slab.

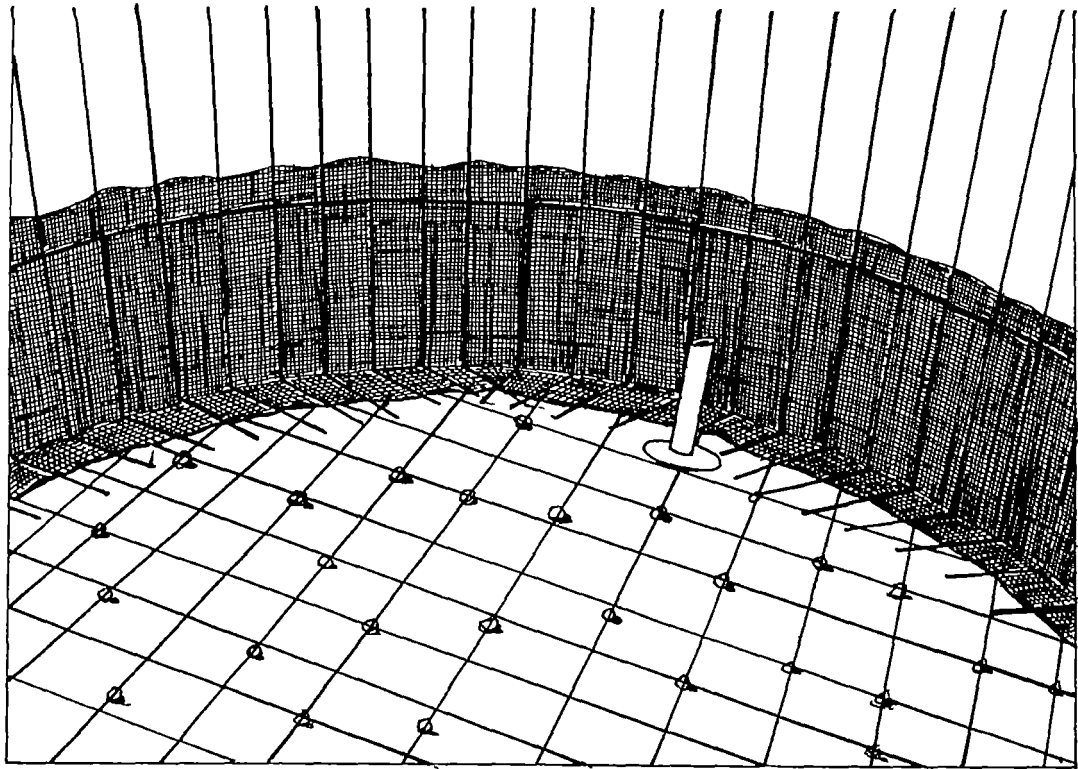

3.6 FLOOR CONCRETING

The mix generally used for concrete works in water retaining structures is 1:1 1/2:3 (20mm). However for the floor concrete in these tanks 1:2:4 (20mm) concrete would suffice. This is possible as all internal facets of the tanks are being rendered and finished water tight using neat cement finish. Special care has to be taken to ensure that the wall reinforcement are not displaced or shifted during the concreting.

3.7 REINFORCEMENT FOR THE WALL

After concreting the floor the starter reinforcement of the wall has to be straightened and cleaned free of all cement grout and other dirt.

Assembly of wall reinforcement needs a good deal more care and attention than is needed in other operations. This is mainly to ensure that the structure is formed true to line and shape, a factor that determines the quality of the final construction.

It is necessary therefore to use some supports internally to meet this requirement. For this purpose use two circular stiffeners made of 10mm Tor steel. One is placed halfway on the wall and the other at the maximum height of the wall. The two stiffeners are aligned vertically horizontally and held in position using cross supports. Once this is done the 6.4mm vertical skeletal steel bars are tied on to the stiffeners. The GI woven mesh is then tied round the vertical steel. The horizontal laps of the mesh shall be 50mm and the vertical laps 200mm as discussed earlier.

On completion of tying the mesh in place it is necessary to re-check the verticality or the reinforcement structure. Any corrections of deviations from true shape or line should be carried out at this stage prior to proceeding any further.

The main reinforcement of the wall viz. the G.I. straight wire is finally tied round the wall outside the mesh spirally, at the specified spacing. It is advised to use a gauge cut to the appropriate spacing to ensure that the correct spacing is maintained.

Verticality of the reinforcement structure has to be maintained at all times and any deformities have to be corrected immediately. Also, make sure that all free ends of the G.I. binding wire is on the inside face of the tank and are kept against the mesh.

IMPORTANT !

It is essential at this stage to erect all necessary scaffoldings with an access to the inside of the tank. Make sure these are independent of the structure.

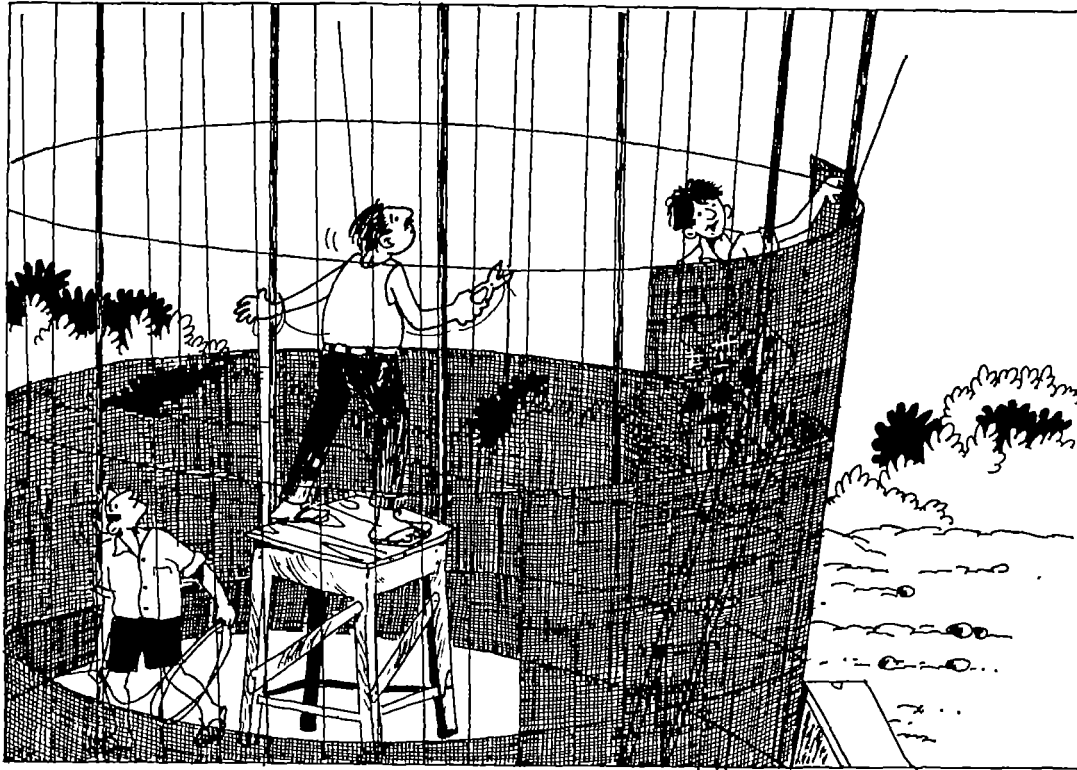

3.8 APPLICATION OF CEMENT MORTAR TO OUTSIDE OF WALL

In the construction of these tanks it is necessary to plaster the outside before the inside.

Following section explains how the outside plaster is applied. **Before commencing plastering of wall ensure that the required number of Masons and unskilled labour are available and adequate stocks of cement sand etc. too are available with easy access.** It is necessary to sieve the sand before hand.

For measuring the volumes of sand for the mix it is advised to use a gauge box. Volume batching using head pans or wheel barrows should be avoided. The mortar mix used for plaster is 1:3 (cement : sand)

Mixing of mortar should be carried out in small batches of not more than the equivalent of one bag of cement. It should be done on a pre-prepared surface either cement paved platform or a wooden plat from with a metal sheeting. Cement and sand in the correct proportions are to be dry mixed thoroughly. Add the required amount of water in small quantities to this pile mixing it thoroughly until a consistent workable mortar mix is obtained.

Apply the mortar onto the reinforcement cage starting from bottom and gradually moving upwards. Care should be taken to force the mortar well into the mesh so that no cavities are formed between the wire and the mortar.

The wall extends 100 mm above the operating water level of the tank. Once this level is reached it is necessary to ensure the verticality of the tank wall. For this purpose level pads are embedded in the wall which will define the vertical line.

A second layer of mortar is applied on the previous layer, and finished smooth with the surface of the level pad, thus ensuring verticality from bottom to top. This layer also should be applied from bottom to top. The combined thickness of the plaster should be approximately 20mm. This final application of the mortar should be carried out while the previous layer is still green and within 30 - 45 minutes.

The fillet at the wall joint too is formed at this stage. Since this is the final plastering operation it is necessary that it is finished smooth with neat cement, true to line and level.

The top of the wall plaster has to be levelled off and adequate covers are to be provided to protect the fresh mortar application from damage.

Curing of the finished outside plaster can commence 4 to 6 hours after completion of the application. A spray of water is appropriate for this purpose.



3.9 APPLICATION OF CEMENT MORTAR TO INSIDE WALL

Internal wall plaster can commence on the following day. All internal supports, steel stiffeners etc. are to be carefully, removed taking care not to exert any force on the wall, whilst removing such supports..

All loose material should be brushed off from the face of the old plaster using a coir brush. The inner face too is plastered using the same mortar mix. Before applying the mortar wet the receiving face adequately with lean cement grout.

The fillet at the base wall joint too is laid along with the laying of internal wall plaster. In smaller tanks it is possible to complete the internal wall plaster and the floor rendering on the same day. However, in larger capacity tanks this will not be possible, and the recommended approach is as follows.

The plastering of the wall section is carried out first, including the fillet in one continuous operation. This is also done in two stages the initial plastering and subsequent cement rendering making upto a finished thickness of approximate 20 mm. The floor rendering is carried out on the next day (see sketch).

For better water tightness a water sealant compound such as pudlo cement could be used in the internal plaster in a proportion of 5% by volume. However, this is not an absolute requirement.

The internal wall plaster too should be leveled off in line with the outer plaster.

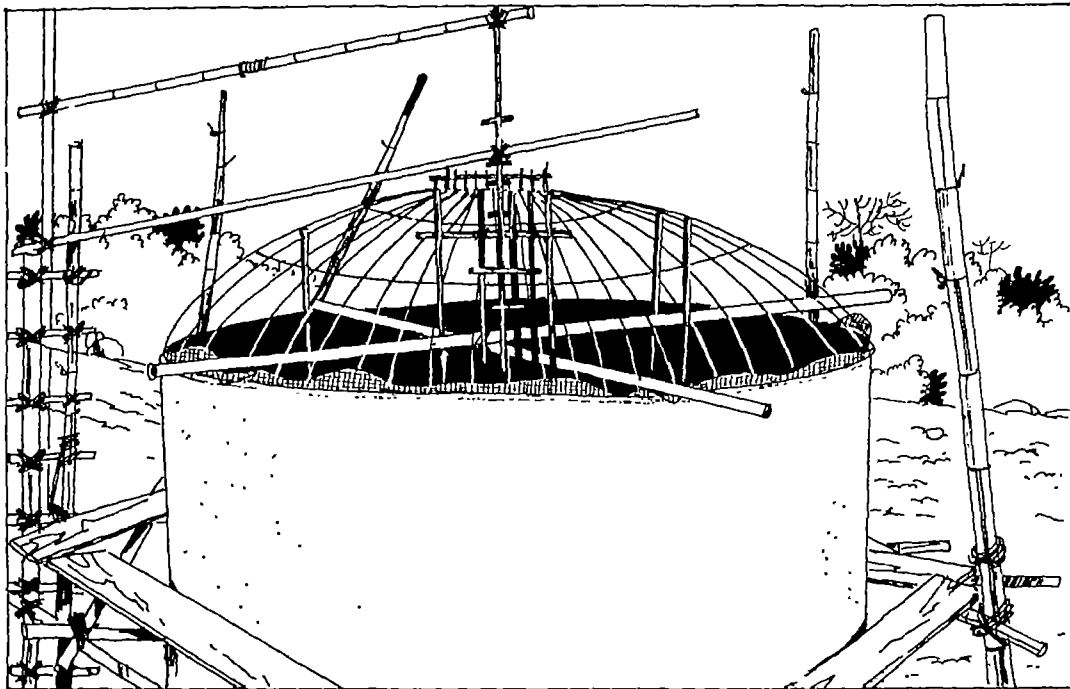

3.10 FLOOR RENDERING

The same mix proportion is used for the floor rendering. In finishing the floor it is necessary to make sure that the floor slopes towards the common outlet at the middle so as to facilitate complete draining.

The construction joint between the floor rendering and the wall plaster may crack open due to shrinkage and leave room for leaks. This could be overcome by providing a thin groove at this joint and finally filling it up with cement grout or some bituminous sealer material.

It is essential to ensure that continuous curing of all finished facets is carried out throughout.

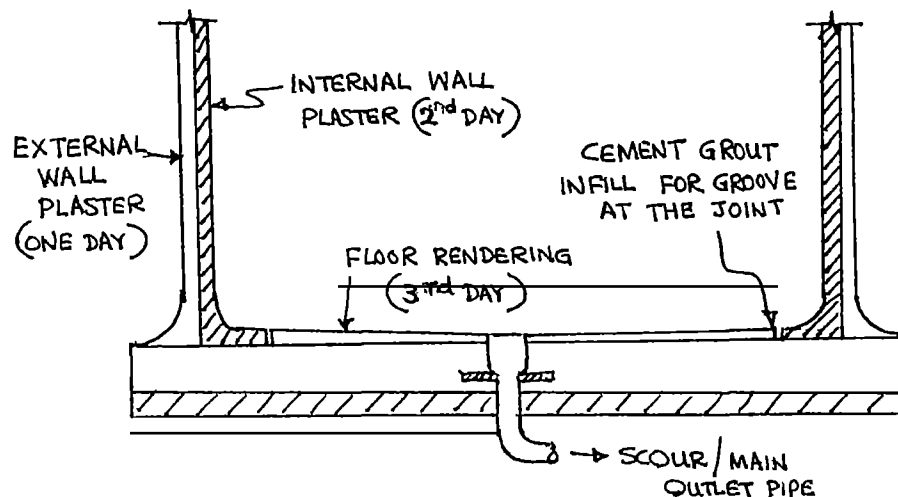

3.11 REINFORCEMENT FOR THE ROOF CUPOLA

Before proceeding with the roof construction it is necessary to seal the possible seepage path along the steel perimeter of the wall. This can be achieved to some extent by pouring a thin mix of cement grout filling the cavities at the line of steel. (joint of the internal and external plastering).

A ring having a diameter equal to the diameter of the access opening is made with a 10mm tor steel rod. This is supported carefully with 4 props at the required height. The centre of this ring should align with the central axis of the tank. 6mm vertical bars are bent to conform to the shape of the roof dome and tied to the steel ring at the crown. A template can be used to guide the bending of these bars to the required shape. The mesh is tied in position over the vertical steel followed by the GI straight wire. At the roof the spacing of straight wire is increased to 100mm.

In tying the steel in place in the roof cupola it is advantageous to have the free ends of the binding wire to the outside unlike in the case of wall.

Additional supports may be used if the roof span is larger.

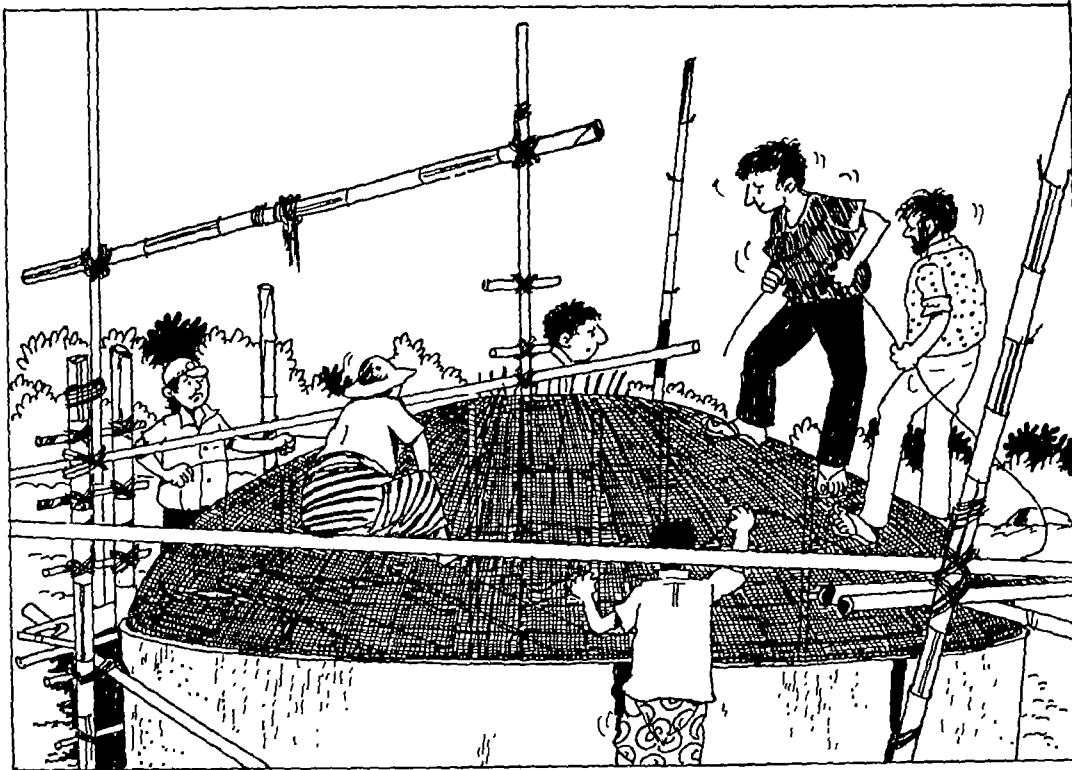

3.12 APPLICATION OF CEMENT MORTAR TO OUTSIDE OF ROOF CUPOLA

Application of mortar in the roof cupola too is similar to that on the wall. The same mortar mix is used and is done in two layers, the final layer being finished smooth with neat cement. Provision has to be kept for anchoring the access ladder hinges for the lid, vent outlet etc on the roof.

In plastering the roof cupola it should be noted that absolutely no loading is exerted on the structure. It is therefore essential that all necessary scaffoldings are provided before hand, independent of the structure and enabling easy access even to the inside of the tank.

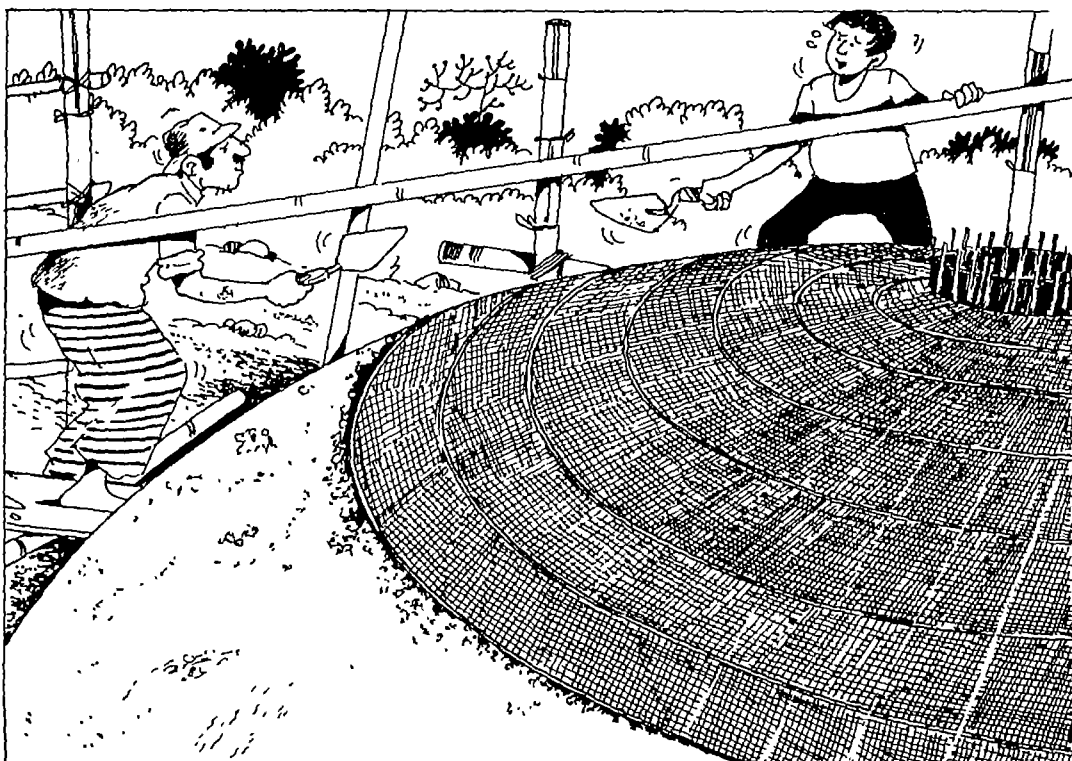

3.13 APPLICATION OF CEMENT MORTAR TO THE SOFFIT OF ROOF CUPOLA

It is possible to remove all supports of the roof cupola after 24 hours. However care shall be taken not to exert force in removing such supports. The soffit plaster too is finished in two layers. It is preferred to finish the soffit too, smooth with neat cement.

3.14 COMPLETION OF THE ACCESS OPENING

The access opening to the tank is provided at its crown. An upstand ring beam is formed with the same mix of mortar to a thickness of 50mm and upstanding 50 ems from the top of the roof.

3.15 INSTALLATION OF THE OVERFLOW & VENT PIPE

The overflow outlet is provided from the floor of the tank. It is extended through the roof to form the vent as well. Since the section of the pipe projecting out of the tank is exposed to the sun, this part of the pipe should be G.I. The conversion from PVC to G.I. is carried out within the tank and the G.I. socket is embedded in the roof structure as shown in the figure.

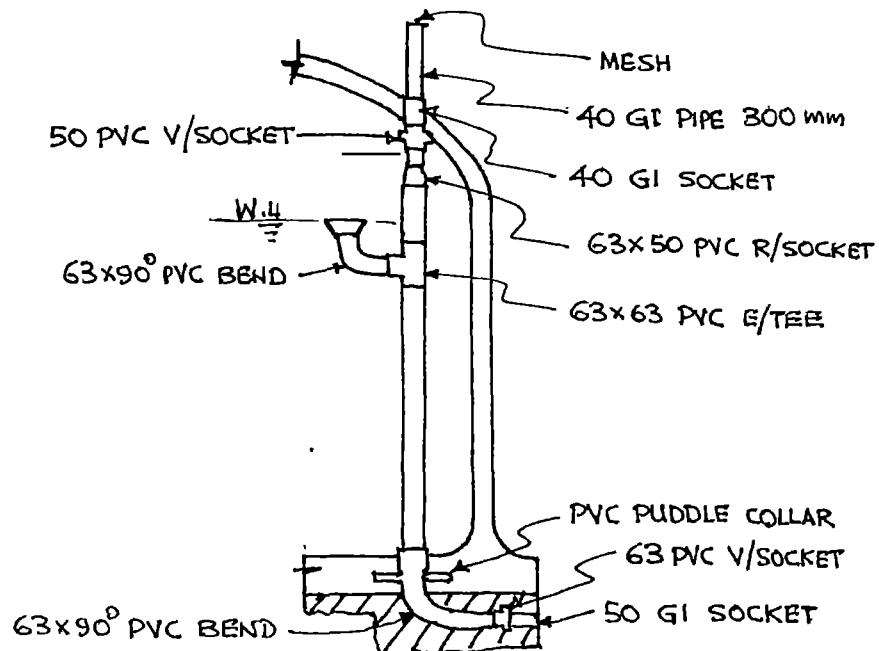

3.16 INSTALLATION OF LADDER & COVER FOR ACCESS OPENING

The access ladder is pre-fabricated and an integral hinged cover is provided for the access opening. 20mm G.I. pipes and 10m Tor Steel can be used for fabricating the ladder and the cover can be fabricated with either sheet metal or glass fibre. It is preferable to fabricate the lid out of a lighter material even though it is possible to fabricate one out of cement mortar too. The ladder fabricated to the shape of the tank has to be simply supported anchored at ground and at the crown of the roof cupola only.

3.17 PAINTING

To protect the tank from the elements and also for aesthetics the tanks are painted in a lighter shade of weather proof paint. This paint shall be applied in two coats over a prime coat of lime wash.

All metal parts are painted with anticorrosive paint applied in two coats.

3.18 INSTALLATION OF VALVES & CONSTRUCTION OF VALVE CHAMBERS.

These tanks are usually provided with one valve chamber housing the inlet, outlet and scour valves provided as indicated in the detail drawings.

The size of the chamber is decided to meet specific requirements. The construction is of 100 x 150 x 300 sandcrete blocks (cement/sand) in cement mortar.

3.19 LANDSCAPING

As in all other construction works , it is of importance to ensure that, the area in the vicinity of the structure is kept free from debris, heaps of earth etc. It is necessary to level the immediate surrounding area of the structures and provide grass turving or stone pitching where appropriate to arrest any possible damage due to erosion.

The tank is liable to damage by impact from heavy objects such as large boulders, falling trees and other heavy articles etc. Hence it, is important to eliminate any such objects that may endanger the structure.

4. CURING

Continuous curing of the various components of construction is of utmost importance. The final strength and quality of the structure depends to a great extent on the effectiveness of curing process apart from the other contributing factors. Wet hesian hung over the completed faces is one way of carrying out effective curing or on the alternative continuous spraying of water has to be done.

5. IMPOUNDING

Impounding of the tank should be phased out and done in stages. This could begin immediately after finishing the wall and the floor rendering. Filling should be done at the rate of not more than 150mm (6") layer of water every day.

Normally the tank could be fully impounded within a few days after the completion of the structure if this process is followed.

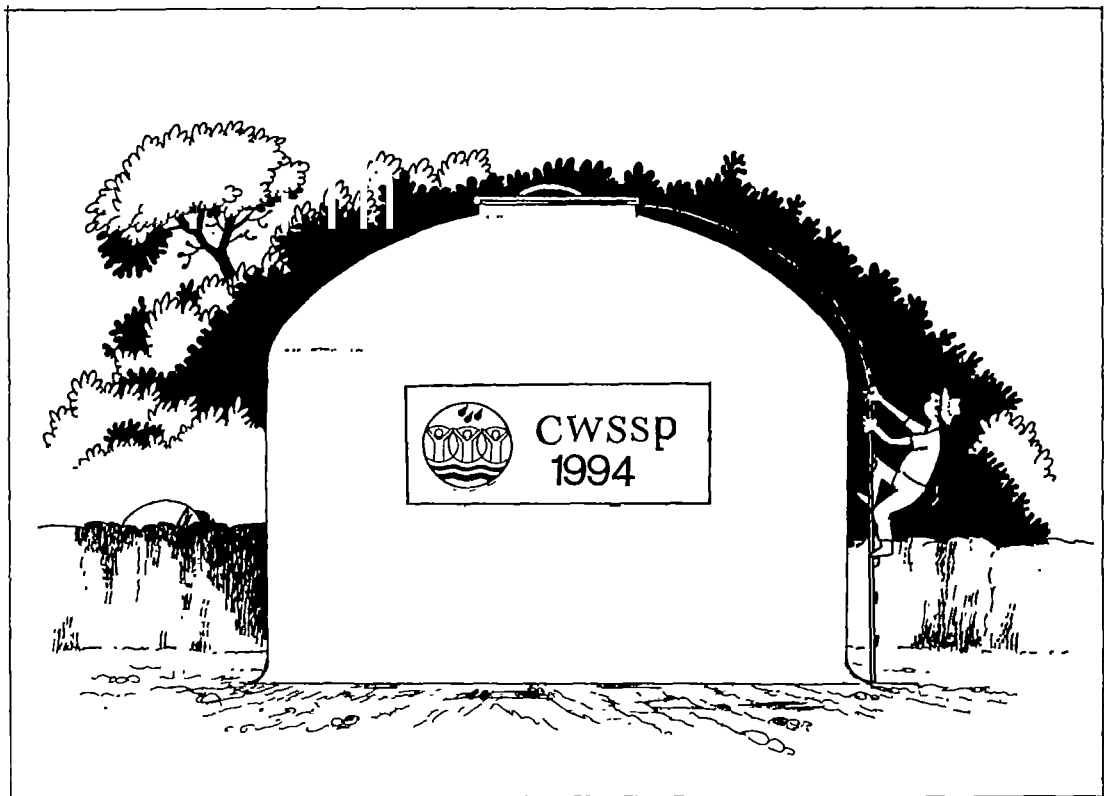

WIRE - REINFORCED - CEMENT MORTAR TANKS
DIMENSIONS OF TANKS OF VARYING CAPACITY
 (all dimensions are in millimeters)

Tank Capacity		3 M ³	5 M ³	6 M ³	8 M ³	10 M ³	15 M ³	20 M ³	30 M ³
Dimension									
A -	INTERNAL DIAMETER	1600	2000	2200	2400	2500	3050	3500	4300
B -	BASE DIAMETER	1880	2280	2480	2680	2780	3330	3780	4580
C -	WALL THICKNESS	40	40	40	40	40	40	40	40
D -	WALL HEIGHT	1600	1700	1700	1500	2200	2200	2200	2200
E -	MAXIMUM WATER HEIGHT	1500	1600	1600	1900	2100	2100	2100	2100
F -	DOME HEIGHT	350	350	400	450	450	500	650	800
G -	ACCESS OPENING DIAMETER	600	600	600	700	700	700	700	750

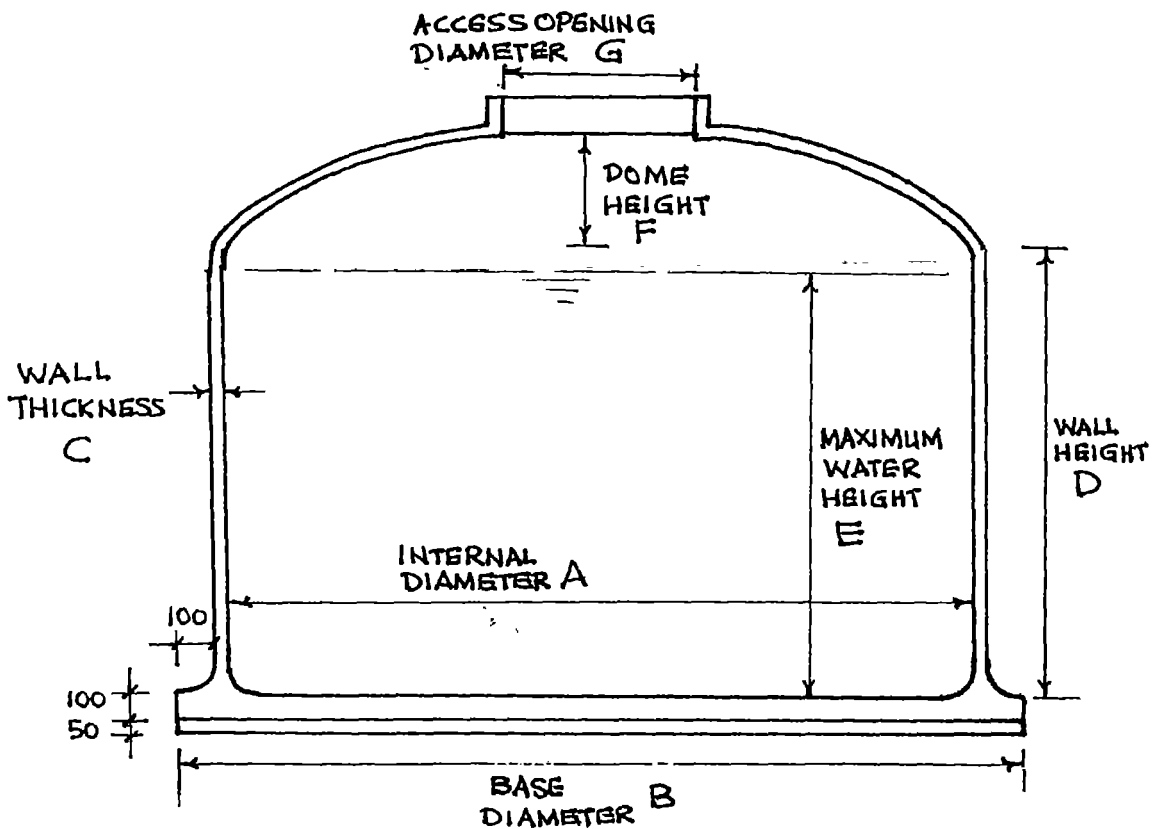

DOME SHAPES - 30CM - 30CM CAPACITY TANKS

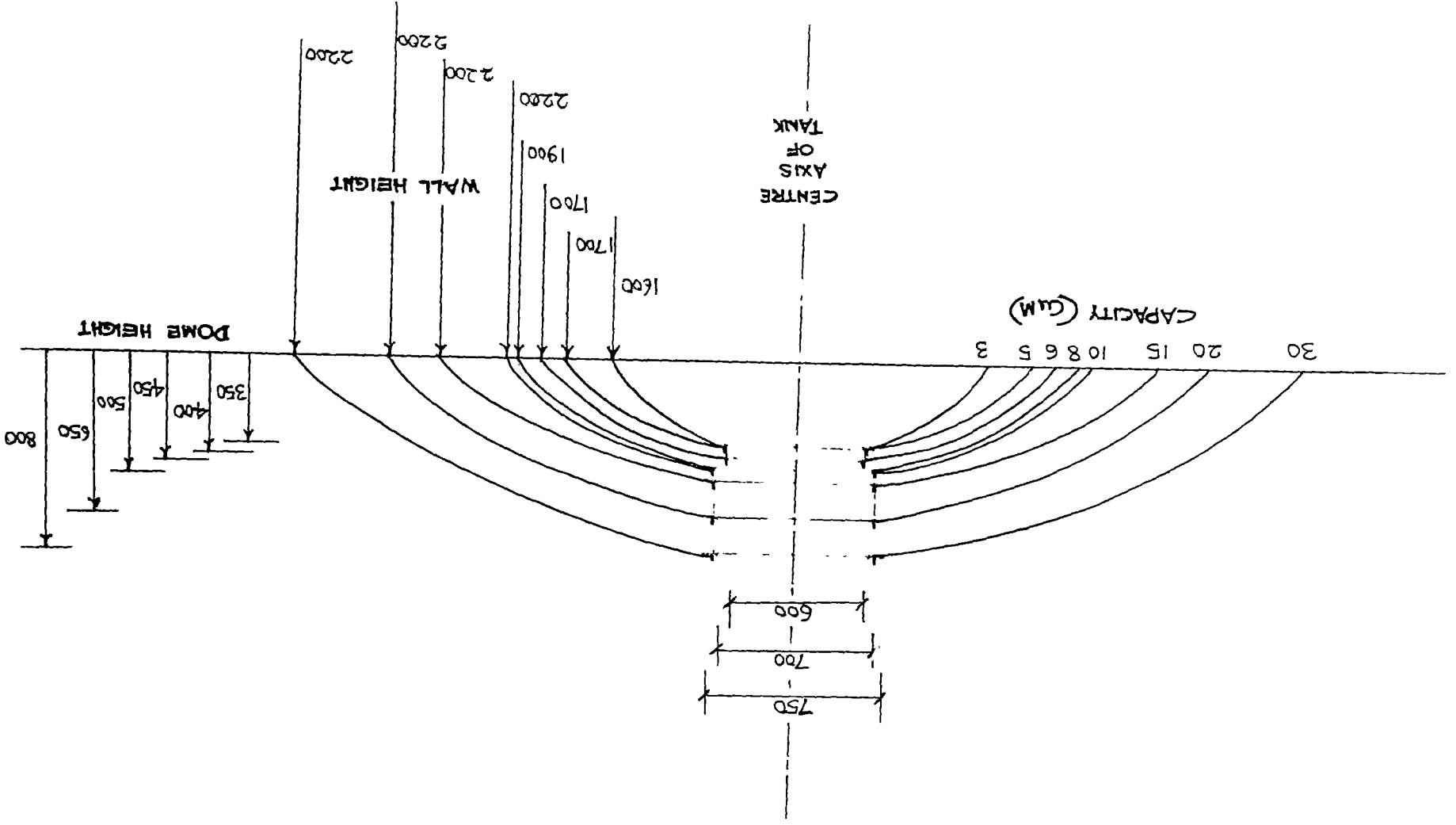

TYPICAL VALVE ARRANGEMENT

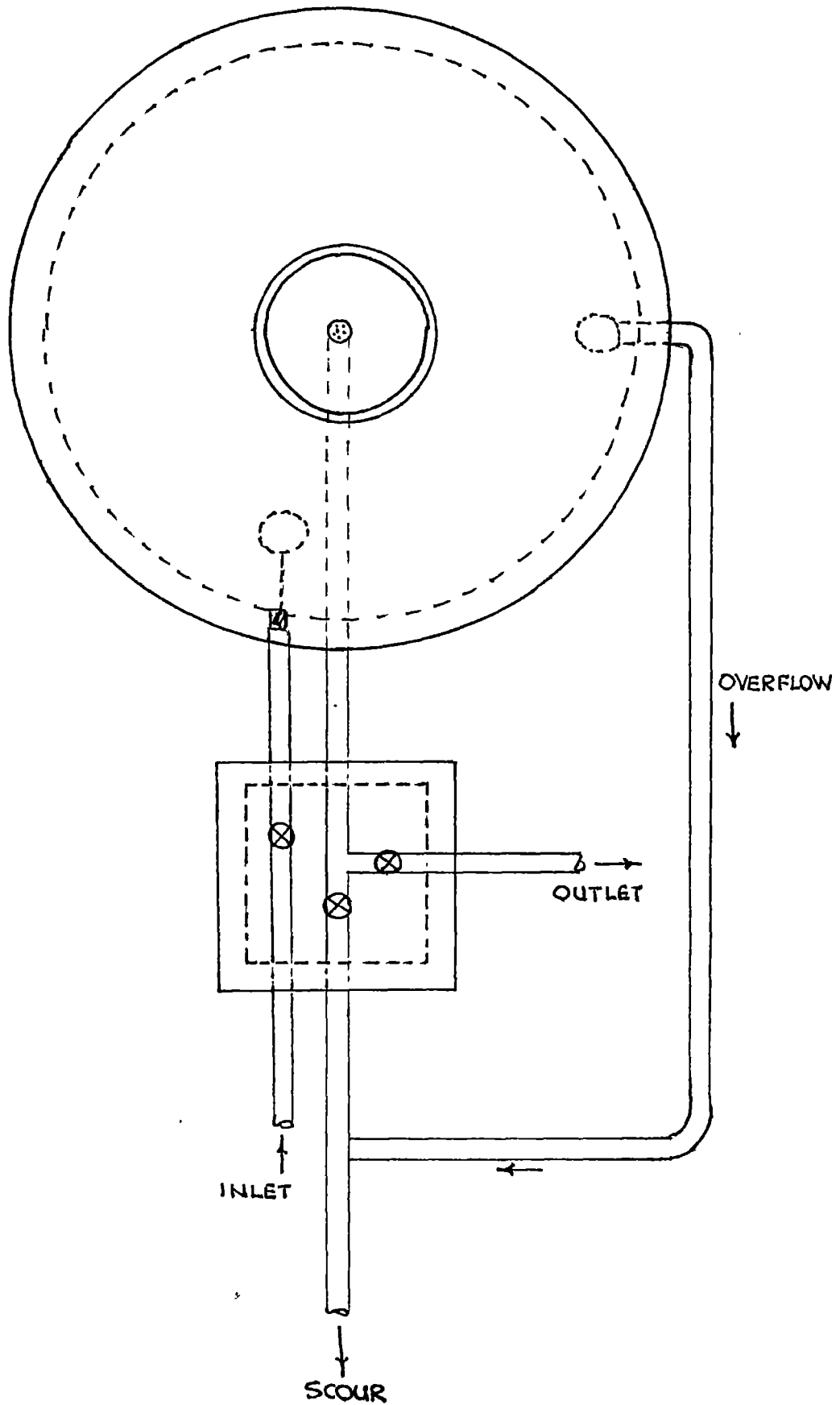

CONSTRUCTION OF WIRE-REINFORCED-CEMENT MORTAR TANKS (CAPACITIES FROM 3 CUM - 30 CUM)

MATERIALS SCHEDULE

Tank Capacity	3 M ³	5 M ³	6 M ³	8 M ³	10 M ³	15 M ³	20 M ³	30 M ³
Item (Unit)								
Cement (50Kg Bag)	16	20	22	26	30	34	42	52
Sand (M ³)	2	2.5	3	4	5	7	8	10
20mm Metal (M ³) (3/4")	0.65	0.90	1	1.2	1.3	1.75	2.20	3
10mm TOR Steel (Kg)	30	40	42	45	50	70	90	130
6mm Mild Steel (Kg)	15	20	22	25	30	38	60	75
G.I. Woven Mesh No. 4 SWG 20 (M ²)	14	18	20	24	28	35	-	-
G.I. Woven Mesh No. 4 SWG 18 (M ²)	-	-	-	-	-	-	42	54
G.I. Wire 2.5 mm (Kg)	7	10	-	-	-	-	-	-
G.I. Wire 3.0mm (Kg)	-	-	15	18	22	28	-	-
G.I. Wire 4 mm (Kg)	-	-	-	-	-	-	50	70
G.I. Binding Wire SWG 18 (Kg)	1	2	2	2.5	3	4.5	07	09
Sancrete Block 100x150x300 (No)	40	40	40	40	40	40	40	40

LABOUR SCHEDULE

Tank Capacity	3 M ³	5 M ³	6 M ³	8 M ³	10 M ³	15 M ³	20 M ³	30 M ³
Category								
Skilled	10	16	18	20	24	26	28	36
Unskilled	20	30	34	38	45	50	65	80

1
2
3
4
5