

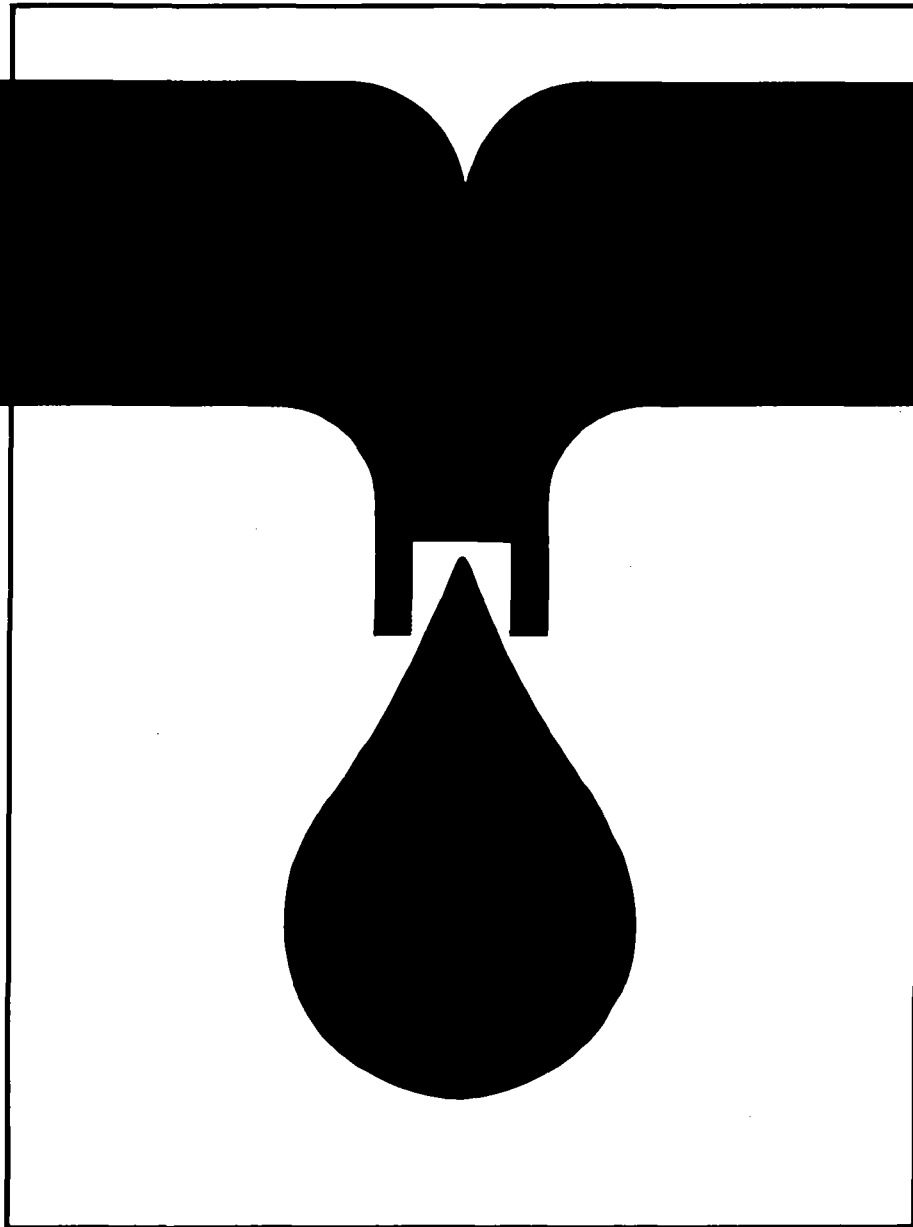

# TRAINING MODULES FOR WATERWORKS PERSONNEL



Special Knowledge

**2.3 h**

Design, functioning, operation, maintenance and repair  
of hoisting gear

262.0-8132 CC

8132  
262.0 87TR (2)

## Foreword

Even the greatest optimists are no longer sure that the goals of the UN "International Drinking Water Supply and Sanitation Decade", set in 1977 in Mar del Plata, can be achieved by 1990. High population growth in the Third World combined with stagnating financial and personnel resources have led to modifications to the strategies in cooperation with developing countries. A reorientation process has commenced which can be characterized by the following catchwords:

- use of appropriate, simple and – if possible – low-cost technologies,
- lowering of excessively high water-supply and disposal standards,
- priority to optimal operation and maintenance, rather than new investments,
- emphasis on institution-building and human resources development.

Our training modules are an effort to translate the last two strategies into practice. Experience has shown that a standardized training system for waterworks personnel in developing countries does not meet our partners' varying individual needs. But to prepare specific documents for each new project or compile them anew from existing materials on hand cannot be justified from the economic viewpoint. We have therefore opted for a flexible system of training modules which can be combined to suit the situation and needs of the target group in each case, and thus put existing personnel in a position to optimally maintain and operate the plant.

The modules will primarily be used as guidelines and basic training aids by GTZ staff and GTZ consultants in institution-building and operation and maintenance projects. In the medium term, however, they could be used by local instructors, trainers, plant managers and operating personnel in their daily work, as check lists and working instructions.

45 modules are presently available, each covering subject-specific knowledge and skills required in individual areas of waterworks operations, preventive maintenance and repair. Different combinations of modules will be required for classroom work, exercises, and practical application, to suit in each case the type of project, size of plant and the previous qualifications and practical experience of potential users.

Practical day-to-day use will of course generate hints on how to supplement or modify the texts. In other words: this edition is by no means a finalized version. We hope to receive your critical comments on the modules so that they can be optimized over the course of time.

Our grateful thanks are due to

Prof. Dr.-Ing. H. P. Haug  
and  
Ing.-Grad. H. Hack

for their committed coordination work and also to the following co-authors  
for preparing the modules:

Dipl.-Ing. Beyene Wolde Gabriel  
Ing.-Grad. K. H. Engel  
Ing.-Grad. H. Hack  
Ing.-Grad. H. Hauser  
Dipl.-Ing. H. R. Jolowicz  
K. Ph. Müller-Oswald  
Ing.-Grad. B. Rollmann  
Dipl.-Ing. K. Schnabel  
Dr. W. Schneider

It is my sincere wish that these training modules will be put to successful use and will thus support world-wide efforts in improving water supply and raising living standards.

Dr. Ing. Klaus Erbel  
Head of Division  
Hydraulic Engineering,  
Water Resources Development  
Eschborn, May 1987



Title: Design, functioning, operation, maintenance  
and repair of hoisting gear

Contents:		Page
1.	Introduction and uses	1
2.	Puller	1 - 3
3.	Block and tackle	3 - 4
4.	Chain hoist	5 - 6
5.	Electric chain hoist	6 - 7
6.	Electric cable hoist	7 - 8
7.	Trolleys	8 - 9
8.	Winches	9
9.	Overhead-travelling cranes	10
10.	Accessories	10 - 11



## 1. Introduction and uses

Hoisting gear is required in the installation of hydraulic equipment, pipes and fittings, as well as for pumps, compressors and other units.

The use of hoisting gear is also necessary for maintenance work on heavy fittings and machines.

Depending on the size of the water supply system, the hoisting gear used ranges from pullers to overhead-travelling cranes with permanently installed trolleys.

## 2. Puller

The puller is a manually operated hoisting device with a wire rope; it is light and manageable even under severe loading, has an unlimited pulling length and operates with the same degree of safety and reliability in every direction (horizontal, vertical or inclined).

The nominal pulling power is 1.5 tonnes and can be increased by using guide pulleys.

The load is raised and lowered by means of two pairs of clamping jaws, which pull the wire rope through the device.

A double-layer wire rope should be used; this prevents deformation as a result of the increasing clamping-jaw pressure.

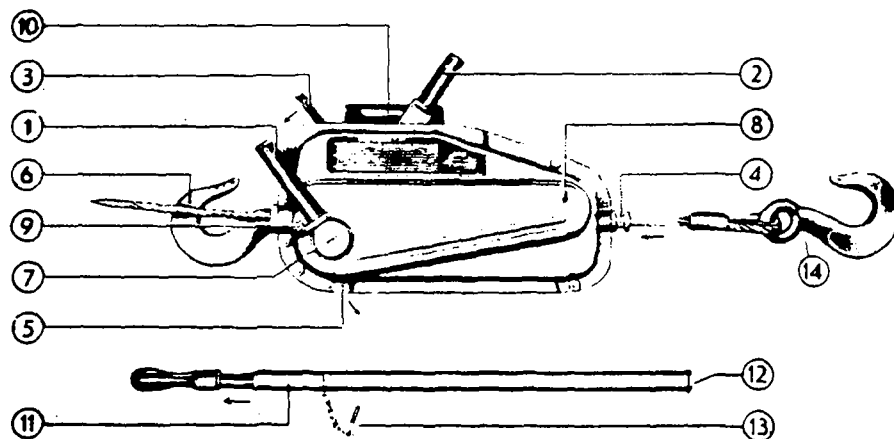

- |                                          |                                    |
|------------------------------------------|------------------------------------|
| 1 Advance lever                          | 8 Groove for spring bar            |
| 2 Return lever                           | 9 Detent for telescopic lever      |
| 3 Control handle                         | 10 Carrying handle                 |
| 4 Entry point                            | 11 Telescopic lever                |
| 5 Bottom closure                         | 12 Groove for detent               |
| 6 Puller hook                            | 13 Lever extension securing device |
| 7 Crank shaft with washer and screw plug | 14 Rope hook                       |

Fig. 1 Puller

Instructions for using the puller shown in Fig. 1:

Pull control handle (3) in direction of arrow, thereby opening both pairs of clamping jaws.

Move return lever (2) towards control handle (3) and press slightly, straighten pointed end of wire rope, insert through entry point (4) and push through until rope emerges at hook (6).

Check whether the rope can move freely in both directions; if this is not the case, remove rope again and check for damage (use only special wire rope for pullers!). If the rope is undamaged, reinsert as described above.

Pull through (by hand) sizeable quantity of rope emerging at hook and release control handle (3).

Place telescopic lever on advance lever (1), making sure that groove (12) of telescopic lever engages with detent (9) on advance lever. The load is pulled by moving the telescopic lever back and forth.

In the case of heavy loads, extend telescopic lever and secure with pin (13). The load is lowered by operating the return lever (2). Never actuate advance lever and return lever simultaneously!

After use, relieve puller tension completely by actuating return lever (2), then pull control handle (3) and pull out rope; then release control handle (3). The control handle (3) can be actuated only when the puller tension is relieved.

The puller has a load limiting facility. The advance lever (1) is secured to the crank shaft (7) with two shear pins; the pins are sheared off at approx. 2.6 tonnes, i.e. roughly 75% overloading. The load then cannot be hauled or raised further, but can be lowered by actuating the return lever (2).

The sheared-off pins can be replaced as follows in a few minutes:

Secure or lower suspended load, but leave puller under a certain amount of tension to facilitate the work.

Remove screw plug and washer from crank shaft (7).

Remove advance lever (1) from crank shaft (7) using a dismantling tool. If no such tool is available, remove advance lever, with attached telescopic lever, by moving back and forth; if necessary, use a suitable tool to provide leverage or tap gently with a hammer from below.

Remove remnants of old shear pins, cleanly remove burr left as a result of the shearing, thoroughly grease end of crank shaft and refit advance lever on crank shaft. Take two new shear pins from the container in the shaft of the advance lever, grease them and insert them carefully using a hammer, without damaging the crank shaft. Fit washer and screw plug.

The puller is now ready for use again; it must be remembered, however, that the pins were sheared off as a result of a 75% overload. Reeving is therefore advisable in order to distribute the load over two or more rope falls (add a block and tackle).

### 3. Block and tackle

The principle of the block and tackle allows the pulling power to be multiplied as a result of change in the relationship between force and distance (work = force x distance). Around 10-15% must be allowed for frictional losses in the pulley system.

The effect of the block and tackle is illustrated by Figs. 2-5, each of which shows one case of lifting and one of hauling. In all cases shown, the puller and its rope are not subjected to a load of more than 1.5 tonnes. Fig. 2 shows lifting and hauling without reeving. The pulley shown in the "lifting" diagram is used merely for direction-changing purposes and not for reeving, and there is therefore no increase in pulling power. The pulley must nevertheless have a load-carrying capacity of 3 tonnes, as the puller and the load both act on the pulley with 1.5 tonnes in almost the same direction of pull.

Fig. 3 shows single reeving with an increase in pulling power to 3 tonnes in nominal terms, corresponding to an actual figure of around 2.5 tonnes, taking into account the frictional losses resulting from reeving. For hauling one pulley with a load-carrying capacity of 3 tonnes is sufficient.

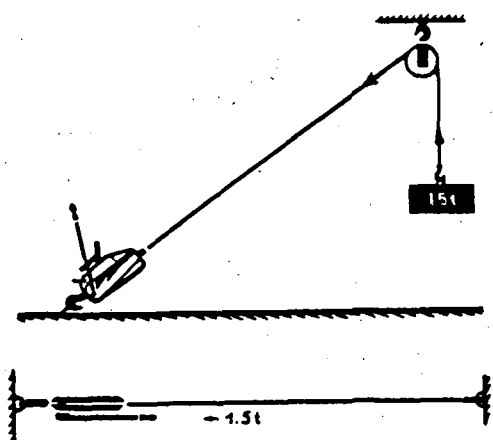

Fig. 2 Puller with guide pulley

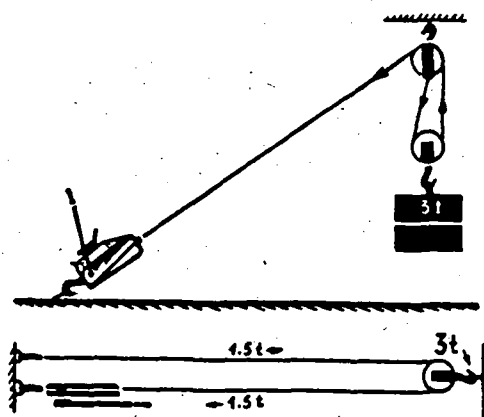

Fig. 3 Puller with block and tackle

For lifting as shown in Fig. 3, two pulleys are required; the top one serves only direction-changing purposes, while the bottom one, as a moving pulley, doubles the pulling power.

Figs. 4 and 5 show the same process with a third pulley in each case.

Theoretically speaking, the block and tackle effect can be continued ad infinitum; in practical use, a system will not go beyond six rope deflections with a pulling power of 10.5 tonnes in nominal terms, corresponding to around 9-tonnes in actual fact.

The blocks required for reeving are available as accessories; they may be of the single-pulley type in a folding design, thereby permitting insertion of the wire rope from the side, or may have two or three pulleys (non-folding design). The rated load of the single-pulley blocks is 3 tonnes and that of the two-pulley and three-pulley blocks 5 tonnes. All blocks are designed with the necessary safety margin; the breaking point of the single-pulley blocks is around 10 tonnes and that of the two-pulley and three-pulley versions around 20 tonnes. If multiple-pulley blocks are required, the three-pulley type should be preferred to the two-pulley type; as it offers further reeving possibilities and, in the case of exceptional use of only one of the pulleys, is subjected to loading in the centre.

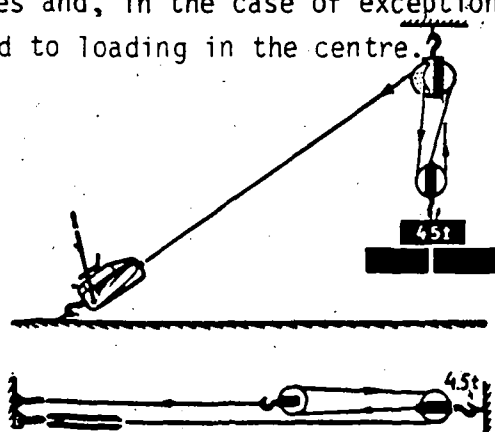

Fig. 4 Puller with block and tackle

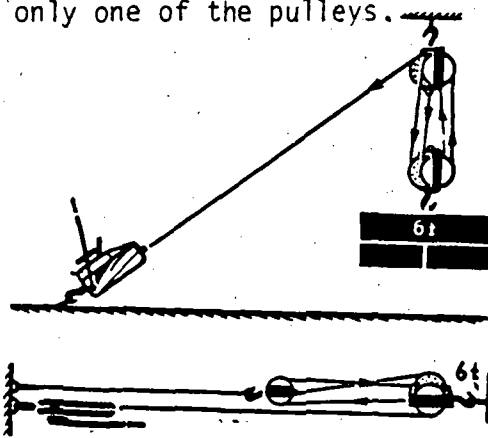

Fig. 5 Puller with block and tackle



#### 4. Chain hoist

The chain hoist is also referred to as a "chain block" and its outstanding feature is its comparatively low weight. This is particularly important if the hoist is used in various places and is attached to a load hook concreted in above the pump.

The multiplication of the pulling power into lifting power is achieved in the example shown here via a cylindrical planetary gear mechanism (Fig. 7).

The planetary gear mechanism consists of a drive pinion (2), planet gears (3) and an internal gear ring (1), all made of high-grade hardened steel.

The load hook and support hook of the chain hoist (3 and 4 in Fig. 6) are drop-forged and can withstand multiple overloading.

The housing shells are dust-tight, so that the built-in ball bearings and needle bearings guarantee a long life and a high degree of efficiency. The handwheel (1) has a return stop and is operated via the manually operated chain (2). Chain hoists of this type are largely maintenance-free, as they have permanent grease lubrication.

The only components requiring regular checks are the brakes and the wearing parts.

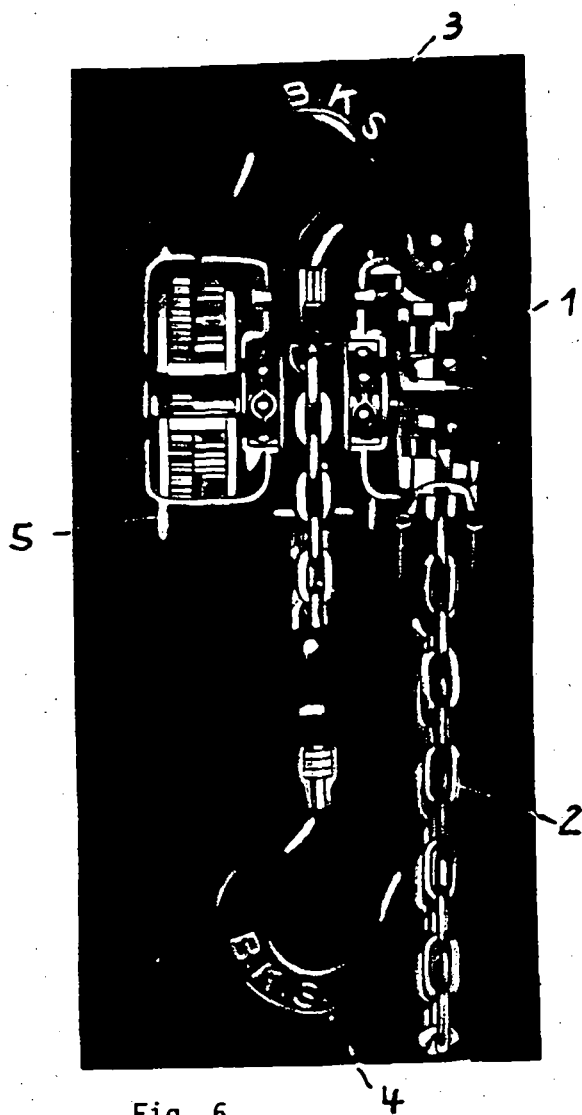
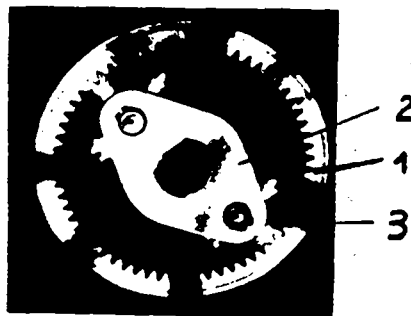

Fig. 6



1 Internal gear ring

2 Drive pinion

3 Planet gear

Fig. 7

Fig. 6

1 Drive wheel with return stop

2 Manually operated drive chain

3 Support hook

4 Load hook

5 Planetary gear mechanism  
with housing

### 5. Electric chain hoist (Fig. 9)

Electric chain hoists are often used in large-scale installations. In terms of design, they are similar to the manually operated chain hoists, except that the manually-operated chain is replaced by a starter which starts up the motor.

Electric chain hoists have a high speed of operation and are simple to use.

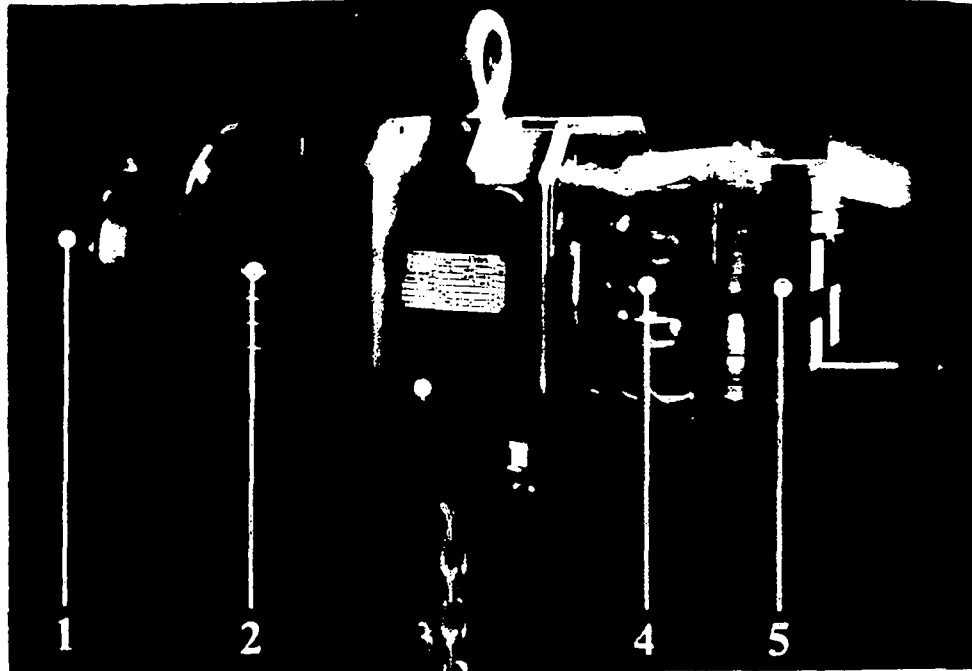

Fig. 9 Electric chain hoist

- 1 Fan for hoisting motor
- 2 Sliding-rotor brake motor
- 3 Chain housing made of nodular cast iron
- 4 Adjustable slipping clutch
- 5 Contactor control

Fig. 8 Manually operated chain hoist

6. Electric cable hoists

Electric cable hoists are used in the case of considerable hoisting heights, as the steel cable can be rolled up more easily than a chain. An electric motor drives a cable drum via a cylindrical or planetary gear mechanism. The motor is often accommodated in the drum to save space.

Through the use of pole-changing hoisting motors, a precision hoisting speed/main hoisting speed ration of 1:6 can be achieved.

The gear mechanism runs in an oil bath and is therefore maintenance-free.

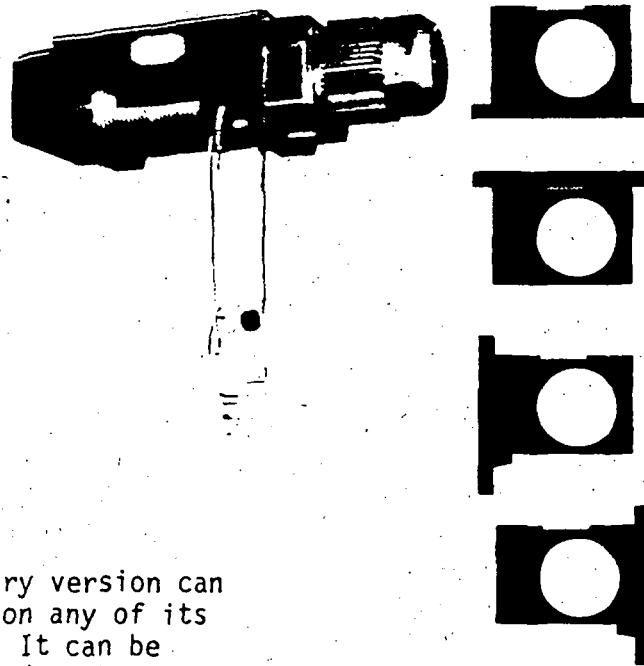

The stationary version can be attached on any of its four sides. It can be easily mounted on bottom-chord and top-chord traverse systems.

Fig. 10 Electric cable hoist

Fig. 10 shows a possible design for an electric cable hoist with four installation alternatives.

### 7. Trolleys

These are used if the load must be moved in the horizontal direction in addition to vertical hoisting. They can be moved along one of the steel girders secured to the ceiling, either by hand or with a chain.

Large trolleys have motors for forward and backward movement.

If suitably designed, trolleys can also travel round bends. Fig. 11 shows a trolley of this type, which is operated either manually or using a chain and in which a manually operated block and tackle or an electric hoist can be suspended.

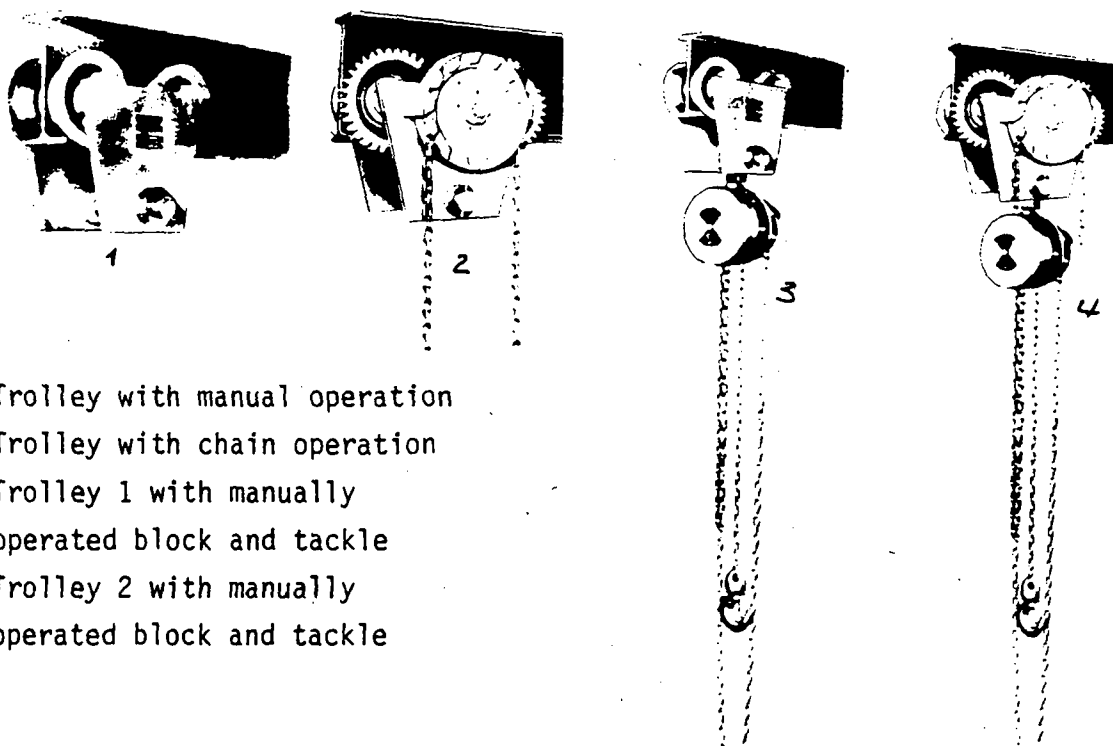

- 1 Trolley with manual operation
- 2 Trolley with chain operation
- 3 Trolley 1 with manually operated block and tackle
- 4 Trolley 2 with manually operated block and tackle

Fig. 11 Trolley

### 8. Winches

Force applied by hand is transmitted by a crank via a gear unit to a rack, screw rod or cable drum. Cable drum winches are often also driven by motors. Fig. 12 shows a winch used for lifting heavy pipe components for assembly purposes.

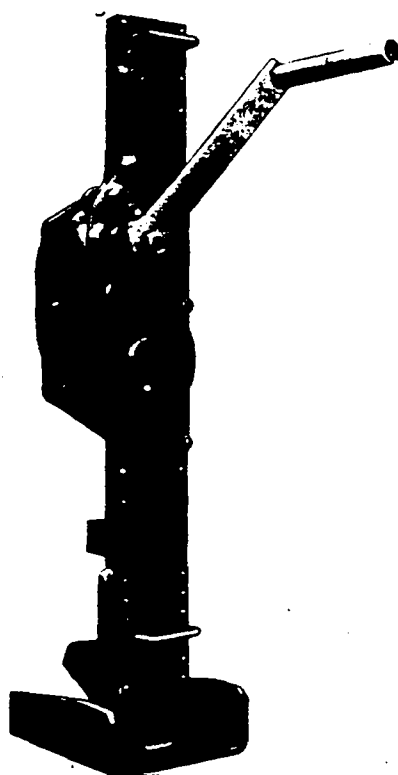

Fig. 12 Winch

## 9. Overhead-traveling cranes

Overhead-travelling cranes are used in waterworks where a number of pumps and fittings etc. are distributed over a sizeable area and the hoisting gear is to be used everywhere. They can move in two horizontal directions and one vertical direction.

Fig. 13 shows an overhead-travelling crane of this type.

The drive power in all directions may also be provided by electric motors. In waterworks, however, manual operation is generally sufficient.

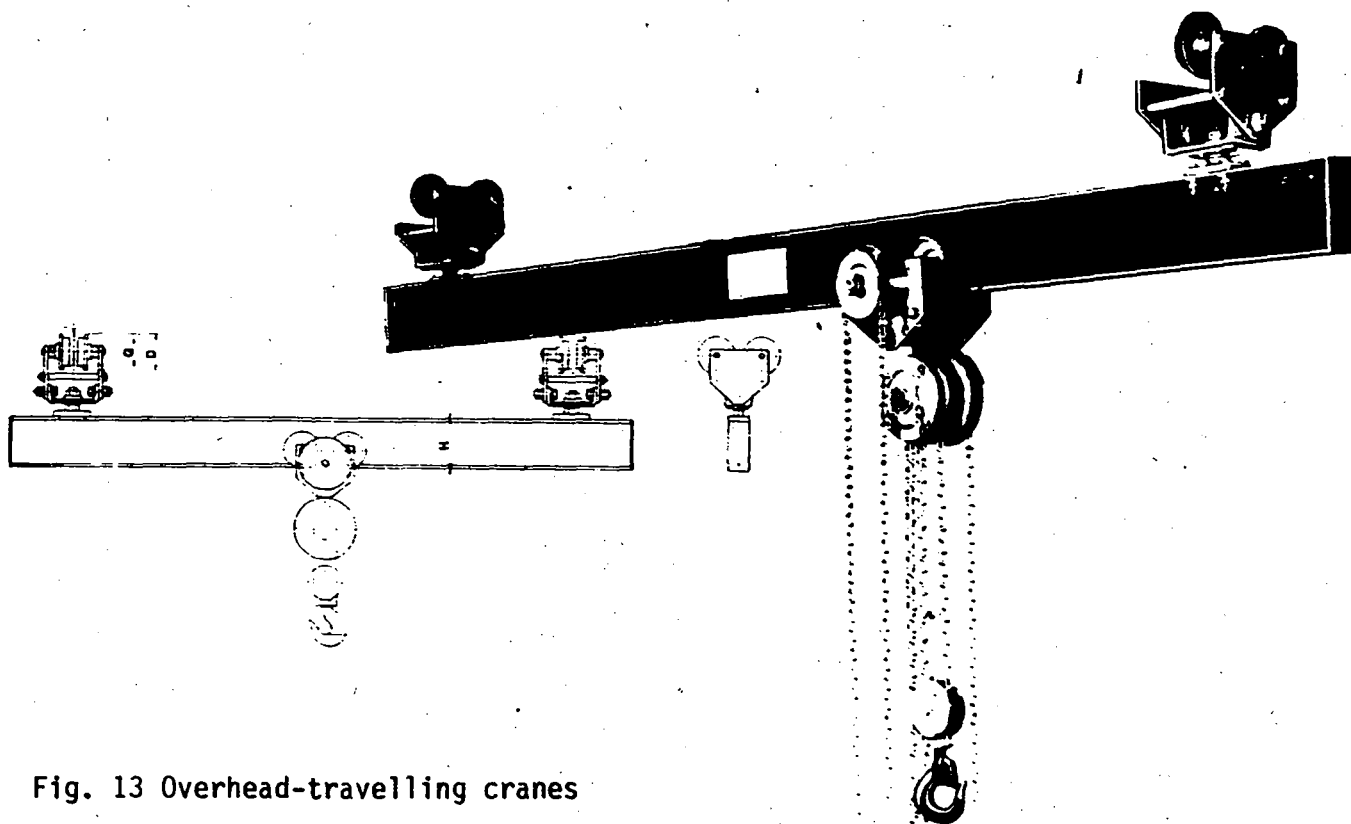

Fig. 13 Overhead-travelling cranes

## 10. Accessories

Fig. 14 shows a number of accessories required for lifting loads.

- 14.1 Slinge rope
- 14.2 Rope lashing
- 14.3 Sling chain
- 14.4 Fibre rope sling
- 14.5 S-shaped hook made of round steel
- 14.6 Hoisting clamps

The accessories shown here will be sufficient for the drinking-water sector.

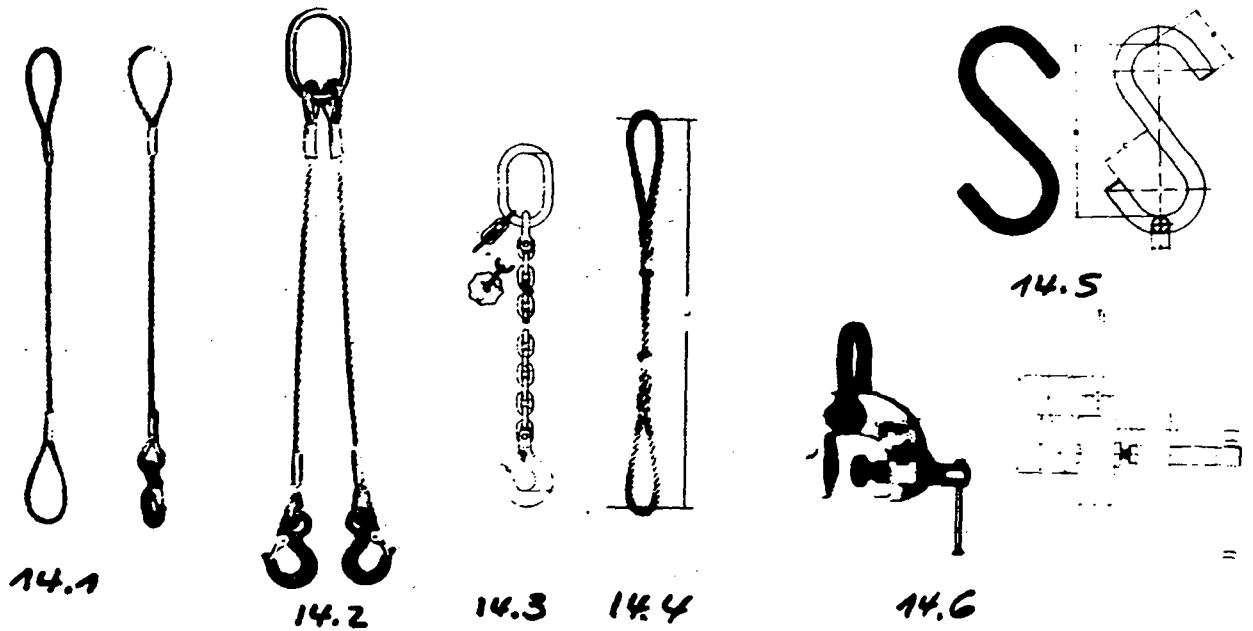

Fig. 14 Accessories



*Deutsche Gesellschaft für Technische Zusammenarbeit (GTZ) GmbH*  
*Dag-Hammarskjöld-Weg 1 + 2 · D 6236 Eschborn 1 · Telefon (0 61 96) 79-0 · Telex 4 07 501-0 gtz d*

The government-owned GTZ operates in the field of Technical Cooperation. Some 4,500 German experts are working together with partners from some 100 countries in Africa, Asia and Latin America in projects covering practically every sector of agriculture, forestry, economic development, social services and institutional and physical infrastructure.

- The GTZ is commissioned to do this work by the Government of the Federal Republic of Germany and by other national and international organizations.

GTZ activities encompass:

- appraisal, technical planning, control and supervision of technical cooperation projects commissioned by the Government of the Federal Republic of Germany or by other authorities
- advisory services to other agencies implementing development projects
- the recruitment, selection, briefing and assignment of expert personnel and assuring their welfare and technical backstopping during their period of assignment
- provision of materials and equipment for projects, planning work, selection, purchasing and shipment to the developing countries
- management of all financial obligations to the partnercountry.

The series "**Sonderpublikationen der GTZ**" includes more than 190 publications. A list detailing the subjects covered can be obtained from the GTZ-Unit 02: Press and Public Relations, or from the TZ-Verlagsgesellschaft mbH, Postfach 36, D 6101 Roßdorf 1, Federal Republic of Germany.



# TRAINING MODULES FOR WATERWORKS PERSONNEL

## List of training modules:

### Basic Knowledge

- 0.1 Basic and applied arithmetic
- 0.2 Basic concepts of physics
- 0.3 Basic concepts of water chemistry
- 0.4 Basic principles of water transport
- 1.1 The function and technical composition of a watersupply system
- 1.2 Organisation and administration of waterworks

### Special Knowledge

- 2.1 Engineering, building and auxiliary materials
- 2.2 Hygienic standards of drinking water
- 2.3a Maintenance and repair of diesel engines and petrol engines
- 2.3b Maintenance and repair of electric motors
- 2.3c Maintenance and repair of simple driven systems
- 2.3d Design, functioning, operation, maintenance and repair of power transmission mechanisms
- 2.3e Maintenance and repair of pumps
- 2.3f Maintenance and repair of blowers and compressors
- 2.3g Design, functioning, operation, maintenance and repair of pipe fittings
- 2.3h Design, functioning, operation, maintenance and repair of hoisting gear
- 2.3i Maintenance and repair of electrical motor controls and protective equipment
- 2.4 Process control and instrumentation
- 2.5 Principal components of water-treatment systems (definition and description)
- 2.6 Pipe laying procedures and testing of water mains
- 2.7 General operation of water main systems
- 2.8 Construction of water supply units
- 2.9 Maintenance of water supply units Principles and general procedures
- 2.10 Industrial safety and accident prevention
- 2.11 Simple surveying and technical drawing

### Special Skills

- 3.1 Basic skills in workshop technology
- 3.2 Performance of simple water analysis
- 3.3a Design and working principles of diesel engines and petrol engines
- 3.3b Design and working principles of electric motors
- 3.3c —
- 3.3d Design and working principle of power transmission mechanisms
- 3.3e Installation, operation, maintenance and repair of pumps
- 3.3f Handling, maintenance and repair of blowers and compressors
- 3.3g Handling, maintenance and repair of pipe fittings
- 3.3h Handling, maintenance and repair of hoisting gear
- 3.3i Servicing and maintaining electrical equipment
- 3.4 Servicing and maintaining process controls and instrumentation
- 3.5 Water-treatment systems: construction and operation of principal components: Part I - Part II
- 3.6 Pipe-laying procedures and testing of water mains
- 3.7 Inspection, maintenance and repair of water mains
- 3.8a Construction in concrete and masonry
- 3.8b Installation of appurtenances
- 3.9 Maintenance of water supply units Inspection and action guide
- 3.10 —
- 3.11 Simple surveying and drawing work



Deutsche Gesellschaft für  
Technische Zusammenarbeit  
(GTZ) GmbH

P. O. Box 5180  
Dag-Hammarskjöld-Weg 1+ 2  
D 6236 Eschborn/ Ts. 1  
Telephone (06196) 79-0  
Telex 407 501-0 gtz d  
Fax No. (06196) 79-1115