

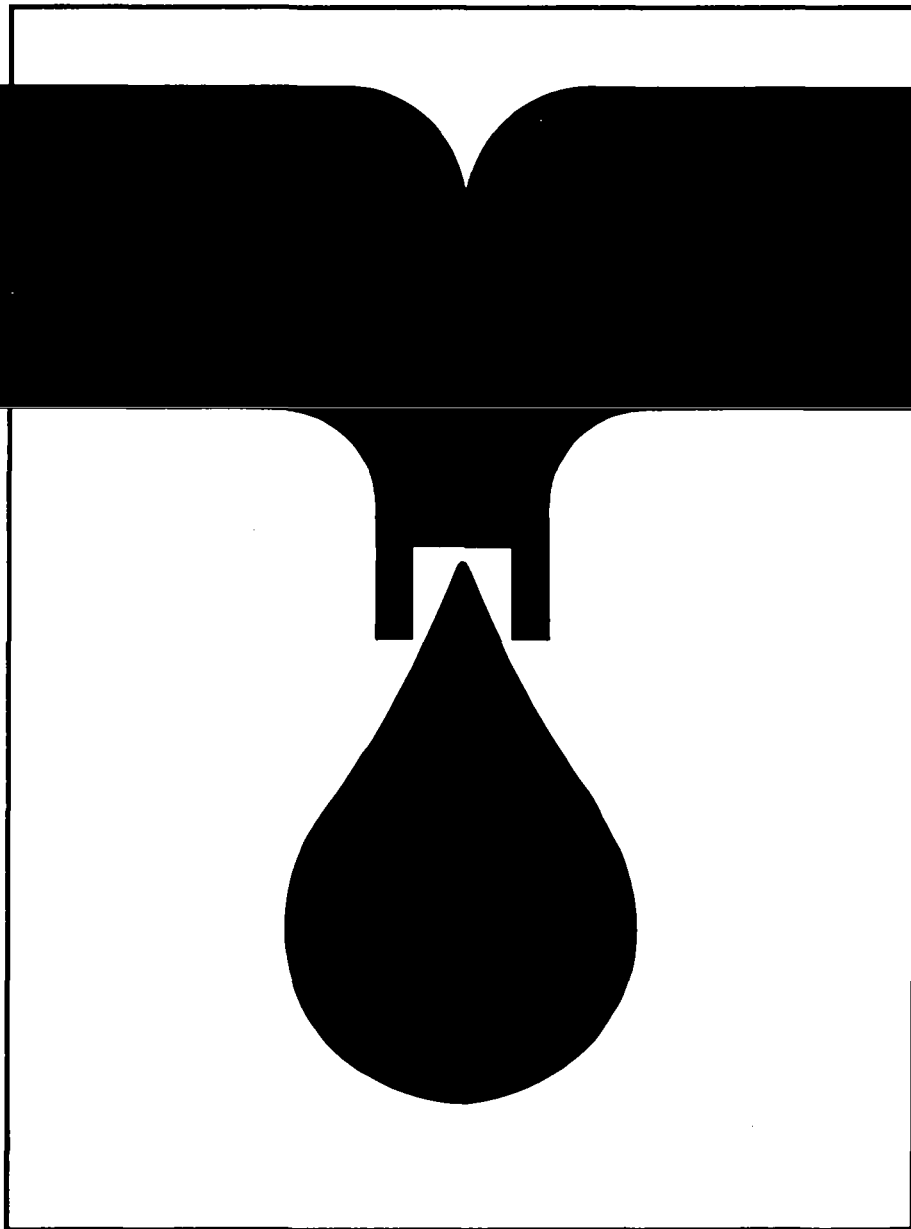

TRAINING MODULES FOR WATERWORKS PERSONNEL



Special Skills

3.3 h

Handling, maintenance and repair
of hoisting gear

GERMAN
COOPERATION, WATERWORKS DEPT.
FOR QUALITY MANAGEMENT

262.0-8132 f }

8132
262.0 87TR (3)

Foreword

Even the greatest optimists are no longer sure that the goals of the UN "International Drinking Water Supply and Sanitation Decade", set in 1977 in Mar del Plata, can be achieved by 1990. High population growth in the Third World combined with stagnating financial and personnel resources have led to modifications to the strategies in cooperation with developing countries. A reorientation process has commenced which can be characterized by the following catchwords:

- use of appropriate, simple and - if possible - low-cost technologies,
- lowering of excessively high water-supply and disposal standards,
- priority to optimal operation and maintenance, rather than new investments,
- emphasis on institution-building and human resources development.

Our training modules are an effort to translate the last two strategies into practice. Experience has shown that a standardized training system for waterworks personnel in developing countries does not meet our partners' varying individual needs. But to prepare specific documents for each new project or compile them anew from existing materials on hand cannot be justified from the economic viewpoint. We have therefore opted for a flexible system of training modules which can be combined to suit the situation and needs of the target group in each case, and thus put existing personnel in a position to optimally maintain and operate the plant.

The modules will primarily be used as guidelines and basic training aids by GTZ staff and GTZ consultants in institution-building and operation and maintenance projects. In the medium term, however, they could be used by local instructors, trainers, plant managers and operating personnel in their daily work, as check lists and working instructions.

45 modules are presently available, each covering subject-specific knowledge and skills required in individual areas of waterworks operations, preventive maintenance and repair. Different combinations of modules will be required for classroom work, exercises, and practical application, to suit in each case the type of project, size of plant and the previous qualifications and practical experience of potential users.

Practical day-to-day use will of course generate hints on how to supplement or modify the texts. In other words: this edition is by no means a finalized version. We hope to receive your critical comments on the modules so that they can be optimized over the course of time.

Our grateful thanks are due to

Prof. Dr.-Ing. H.P. Haug
and
Ing.-Grad. H. Hack

for their committed coordination work and also to the following co-authors
for preparing the modules:

Dipl.-Ing. Beyene Wolde Gabriel
Ing.-Grad. K. H. Engel
Ing.-Grad. H. Hack
Ing.-Grad. H. Hauser
Dipl.-Ing. H. R. Jolowicz
K. Ph. Müller-Oswald
Ing.-Grad. B. Rollmann
Dipl.-Ing. K. Schnabel
Dr. W. Schneider

It is my sincere wish that these training modules will be put to successful use and will thus support world-wide efforts in improving water supply and raising living standards.

Dr. Ing. Klaus Erbel
Head of Division
Hydraulic Engineering,
Water Resources Development
Eschborn, May 1987



Title: Handling, maintenance and repair of hoisting gear

Contents:	Page
1. General guidelines for using hoisting gear	1
2. Maintenance of chain hoists	2-5
3. Maintenance and care of pullers	5-6
4. Repairs and spare parts	6-7
5. Safety instructions	7

1. General guidelines for using hoisting gear

Hoisting gear and cranes which are new or which have undergone major modification may only be put into operation when the acceptance test has been carried out by a competent person in the case of stationary electric cable hoists or by an expert in the case of cranes (trolleys).

Competent persons include, for example, the manufacturers' service fitters; experts include, for example, members of TÜV (German Technical Supervisory Authority) personnel.

The system may be operated only with the performance data as given on the rating plate.

The operator is required to maintain the system in a proper condition, to operate it correctly, to monitor it continuously and to carry out necessary maintenance and repair work without delay.

It is advisable to accommodate electric chain hoists operating out of doors under a small canopy roof which provides sufficient protection against the weather.

The equipment must not be allowed to impact against the ends of the track at full speed, because mechanical damage may result.

The accident prevention regulations stipulate that electrical hoists must not be used to pull a load at an angle; nor may they be used to pull or haul loads or to break them loose.

Phase failure or incorrect operation of the control unit (simultaneous actuation of opposite directions of movement) may lead to an undesired change of direction.

Recurring tests:

Information is contained in the "Basic principles for the testing of cranes", published by the Hauptverband der gewerblichen Berufsgenossenschaften (Confederation of Industrial Insurance Associations). It is recommended to have recurring tests performed by a competent person from the manufacturers.

2. Maintenance of chain hoists

2.1 Before any work is performed on an electric chain hoist, it must be ensured that it is not loaded and has been switched off at the mains.

The maintenance table specifies the parts and functions which must be checked regularly and the work to be performed at regular intervals. If faults are found they must be eliminated immediately. The intervals are geared to normal operating conditions. In the case of difficult operating conditions (e.g. multiple-shift operation) the intervals must be reduced accordingly:

	Months	Daily	Upon commissioning
1. Operation of brakes		x	x
2. Load chain (elongation and abrasion at joints)		x	
3. Operation of emergency limit stop (slipping clutch)		x	x
4. Chain mounting	3		x
5. Clean load chain and lubricate with low-viscosity grease (use lubricating varnish if operated in dusty conditions)	3		x
6. Oil level (up to centre of oil sight glass)	12		x
7. Screw connections, welds, traverse systems (running surfaces, wheel flanges, teeth, buffers, end stops)	12		x
8. Lubricate roller teeth with grease	12		x
9. Load hook and suspension eye (deformation, cracks)	12		
10. Operation of slipping clutch with rated load	12		
11. Oil change, hoisting mechanism	60		
12. Grease change, traverse mechanism	60		

2.2 Maintenance work

Operation of the brakes, illustrated by a hoisting motor (Fig. 1)

The brake lift travel (distance between inoperative position and operating position of motor shaft) is within the permissible tolerance as long as the motor shaft does not project out of the fan cowl when the motor is at a standstill.

If the motor shaft does project out of the fan cowl when the motor is at a standstill, the braking distance of the load will be greater and the brake lift travel must be adjusted.

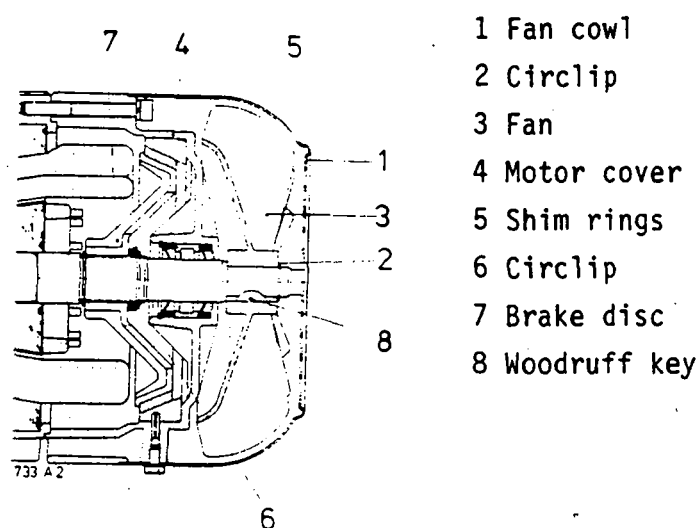

Fig. 1: Hoisting motor

- Measure brake lift travel (switch off motor briefly)
- Determine number of shim rings (5) to be moved; it corresponds to the figure in front of the decimal point in the number which corresponds to the measured value in mm reduced by 1 (e.g. measured value 2.3 mm = 1 shim ring)
- Remove fan cowl (1)
- Remove circlip (2)
- Remove fan (3) and Woodruff key (8)
- Unscrew motor cover (4) (do not pull motor shaft with rotor out of motor!)
- Remove circlip (6), pull off shim rings (5) and brake disc (7)
- Fit the number of shim rings (5) determined in Point 2 on the motor shaft
- Fit brake disc (7) and remaining shim rings (5) on motor shaft; fit circlip (6)
- Install motor cover (4), fan (3) and fan cowl (1)

If all the shim rings have been moved and the motor shaft still projects out of the fan cowl when the motor is at a standstill, the brake disc must be replaced.

Load chain

The load chain is to be replaced immediately if the limit values given in the table (see manufacturer's data) are exceeded at any point in the chain. If a loud clicking is heard when the loaded chain runs over the chain sprocket or a guide pulley, not only the chain, but also the sprocket or pulley, must be checked for wear and replaced if necessary.

Replacement of load chain

- Lower chain until just before lowest hook position
- Release chain mounting and remove chain magazine if applicable
- Remove hook block/tackle and, if necessary, chain stop sprocket
- Allow load chain to run through until around 10 cm is left
- Attach new chain to short end of old chain and run it into the chain hoist. If there is no chain in the hoist, the new chain can be drawn in using a flexible wire which is pushed over the chain sprocket.
- Refit hook block/tackle and chain stop sprocket in reverse order to removal
 - If there is no chain magazine, attach chain stop sprocket to ninth link and last link of the non-loaded chain strand at the side chain mounting bolt
 - If there is a chain magazine, attach chain stop sprocket to penultimate link in loose chain strand

The first and last links of the chain must be perpendicular to the hoist with the weld facing outwards.

If, in the case of two-strand reeving, the chain mounting bolt is deformed or slightly worn, it must be replaced.

Adjusting the slipping clutch

The clutch must be adjusted regularly in accordance with the manufacturer's specifications.

The clutch must not be set to more than 1.25 times the rated load. If it can no longer be adjusted it must be replaced.

3. Maintenance and care of pullers

Despite the effective protection afforded by the steel housing, dust and dirt may enter through the opening in the top of the housing, the two openings for the wire rope and the crank shaft bearing. Particularly when working out of doors, therefore, the puller should not be placed on the ground, but always on a board, metal sheet or similar. If the wire rope becomes dirty, it must be cleaned with a cloth, or adhering mud and dirt otherwise removed, before it enters the device.

The device must be cleaned if it becomes extremely dirty. After opening the bottom flap, remove the worst of the dirt (blow out using compressed air), then rinse the device with kerosine or benzine and subsequently lubricate it.

Frequent and generous lubrication is essential to ensure that the puller operates properly. An excess of lubrication is never harmful and does not affect the grip of the clamping jaws on the wire rope. A lack of lubrication, however, will lead to operating problems as a result of wear, jamming and seizure at the bearing points.

We recommend that normal oil (SAE 20 - 50) be used for lubrication. The oil is poured into the device via the open bottom flap shown in Fig. 1 (5) of Module 2.3.h in a quantity sufficient to penetrate to all bearing points. Good lubrication of the clamping-jaw dogs, crank shaft bearings, spring guide pins and sliding points of the spring guide plates is particularly important. In order to help the oil to penetrate to the clamping-jaw dogs, the control handle (3) shown in Fig. 1 of Module 2.3.h is to be alternately pulled and released when lubricating the two clamping locks. When oiling the crank shaft bearings, the advance lever should be moved. In addition, the lubricating nipple on the crank shaft is to be provided with grease.

Puller rope

The puller requires a special wire rope which can cope with the particular stresses imposed by the device, particularly the clamping jaw pressure which increases in proportion to the load. Ordinary wire ropes are deformed by the clamping-jaw pressure and cause operating malfunctions as a result of crushing in the device. Only the special rope developed for the puller should therefore be used. It is of a double-layer design and is given a particularly reinforced structure by means of an additional manufacturing operation.

An important role in maintenance is played by the regular lubrication of all sliding parts at the correct time.

4 Repairs and spare parts

Repairs should if possible be carried out by specialist personnel. Only in this way can proper repair and functioning of hoisting gear be ensured; the high quality of the equipment is maintained.

During the warranty period, warranty claims can be entertained only if repairs are carried out by manufacturer or by personnel authorized by him.

Spare parts

When spare parts are being ordered the information given below must be stated, for only then can the correct parts be supplied:

1. Type and serial number of the hoist
2. Designation and number of the parts (given in the spare-parts list)

Special instructions apply as regards inspection works on controllers; the VDE (Association of German Electrical Engineers) guidelines must also be observed in this case.

Changing the oil

1. Drain off old oil while still warm.
2. Pour in new oil. The oil level is correct when it reaches oil level plug 1.2 when the chain hoist is horizontal.

5. Safety instructions

The safety instructions issued by the manufacturer and by the relevant professional insurance association must be observed for every type of hoisting gear.

In general, it must be borne in mind that a chain link can snap or a brake fail etc even if the system receives optimum care and maintenance. Provision must be made for such occurrences; no-one should therefore ever work underneath a suspended load or even walk underneath it.

If work has to be carried out on a suspended load, it must be secured by means of a scaffold or timber beams.

It is particularly important not to overload the equipment and, as mentioned at the outset, to observe the data given on the rating plate.



Deutsche Gesellschaft für Technische Zusammenarbeit (GTZ) GmbH
Dag-Hammarskjöld-Weg 1 + 2 · D 6236 Eschborn 1 · Telefon (0 6196) 79-0 · Telex 4 07 501-0 gtz d

The government-owned GTZ operates in the field of Technical Cooperation. Some 4,500 German experts are working together with partners from some 100 countries in Africa, Asia and Latin America in projects covering practically every sector of agriculture, forestry, economic development, social services and institutional and physical infrastructure.

- The GTZ is commissioned to do this work by the Government of the Federal Republic of Germany and by other national and international organizations.

GTZ activities encompass:

- appraisal, technical planning, control and supervision of technical cooperation projects commissioned by the Government of the Federal Republic of Germany or by other authorities
- advisory services to other agencies implementing development projects
- the recruitment, selection, briefing and assignment of expert personnel and assuring their welfare and technical backstopping during their period of assignment
- provision of materials and equipment for projects, planning work, selection, purchasing and shipment to the developing countries
- management of all financial obligations to the partnercountry.

The series "**Sonderpublikationen der GTZ**" includes more than 190 publications. A list detailing the subjects covered can be obtained from the GTZ-Unit 02: Press and Public Relations, or from the TZ-Verlagsgesellschaft mbH, Postfach 36, D 6101 Roßdorf 1, Federal Republic of Germany.

TRAINING MODULES FOR WATERWORKS PERSONNEL

List of training modules:

Basic Knowledge

- 0.1 Basic and applied arithmetic
- 0.2 Basic concepts of physics
- 0.3 Basic concepts of water chemistry
- 0.4 Basic principles of water transport
- 1.1 The function and technical composition of a water supply system
- 1.2 Organisation and administration of waterworks

Special Knowledge

- 2.1 Engineering, building and auxiliary materials
- 2.2 Hygienic standards of drinking water
- 2.3a Maintenance and repair of diesel engines and petrol engines
- 2.3b Maintenance and repair of electric motors
- 2.3c Maintenance and repair of simple driven systems
- 2.3d Design, functioning, operation, maintenance and repair of power transmission mechanisms
- 2.3e Maintenance and repair of pumps
- 2.3f Maintenance and repair of blowers and compressors
- 2.3g Design, functioning, operation, maintenance and repair of pipe fittings
- 2.3h Design, functioning, operation, maintenance and repair of hoisting gear
- 2.3i Maintenance and repair of electrical motor controls and protective equipment
- 2.4 Process control and instrumentation
- 2.5 Principal components of water-treatment systems (definition and description)
- 2.6 Pipe laying procedures and testing of water mains
- 2.7 General operation of water main systems
- 2.8 Construction of water supply units
- 2.9 Maintenance of water supply units Principles and general procedures
- 2.10 Industrial safety and accident prevention
- 2.11 Simple surveying and technical drawing

Special Skills

- 3.1 Basic skills in workshop technology
- 3.2 Performance of simple water analysis
- 3.3a Design and working principles of diesel engines and petrol engines
- 3.3b Design and working principles of electric motors
- 3.3c —
- 3.3d Design and working principle of power transmission mechanisms
- 3.3e Installation, operation, maintenance and repair of pumps
- 3.3f Handling, maintenance and repair of blowers and compressors
- 3.3g Handling, maintenance and repair of pipe fittings
- 3.3h Handling, maintenance and repair of hoisting gear
- 3.3i Servicing and maintaining electrical equipment
- 3.4 Servicing and maintaining process controls and instrumentation
- 3.5 Water-treatment systems: construction and operation of principal components: Part I - Part II
- 3.6 Pipe-laying procedures and testing of water mains
- 3.7 Inspection, maintenance and repair of water mains
- 3.8a Construction in concrete and masonry
- 3.8b Installation of appurtenances
- 3.9 Maintenance of water supply units Inspection and action guide
- 3.10 —
- 3.11 Simple surveying and drawing work



Deutsche Gesellschaft für
Technische Zusammenarbeit
(GTZ) GmbH

P. O. Box 5180
Dag-Hammarskjöld-Weg 1+ 2
D 6236 Eschborn/Ts. 1
Telephone (06196) 79-0
Telex 4 07 501-0 gtz d
Fax No. (06196) 79-1115