

**LIBRARY  
INTERNATIONAL REFERENCE CENTRE  
FOR COMMUNITY WATER SUPPLY AND  
SANITATION (IRC)**

**OPTIMIZING INTRA- AND INTER-SEASONAL WATER  
ALLOCATION FROM AN IRRIGATION RESERVOIR  
SUBJECT TO STOCHASTIC INFLOWS**

**BY**

**ARMAND J. M. EVERS**

**Bachelor of Science  
Wageningen Agricultural University  
Wageningen, The Netherlands  
1979**

**ingenieur  
Wageningen Agricultural University  
Wageningen, The Netherlands  
1982**

**Submitted to the Faculty of the  
Graduate College of the  
Oklahoma State University  
in partial fulfillment of  
the requirements for  
the Degree of  
DOCTOR OF PHILOSOPHY  
December 1992**

272.2-920P-12740

OPTIMIZING INTRA- AND INTER-SEASONAL WATER  
ALLOCATION FROM AN IRRIGATION RESERVOIR  
SUBJECT TO STOCHASTIC INFLOWS

BY

ARMAND J. M. EVERS

Bachelor of Science  
Wageningen Agricultural University  
Wageningen, The Netherlands  
1979

ingenieur  
Wageningen Agricultural University  
Wageningen, The Netherlands  
1982

Submitted to the Faculty of the  
Graduate College of the  
Oklahoma State University  
in partial fulfillment of  
the requirements for  
the Degree of  
DOCTOR OF PHILOSOPHY  
December 1992

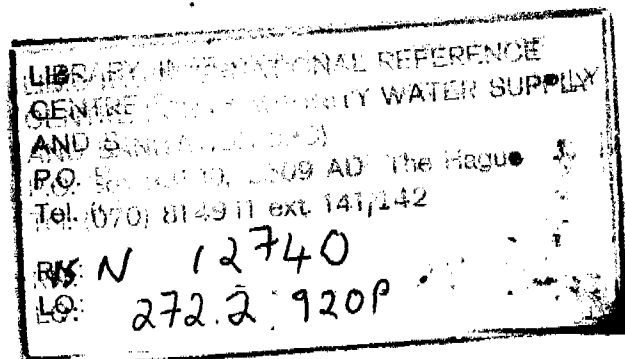

Name: Armand J. M. Evers

Date of Degree: December 1992

Institution: Oklahoma State University

Location: Stillwater, Oklahoma, USA

Title of Study: OPTIMIZING INTRA- AND INTER-SEASONAL WATER  
ALLOCATION FROM AN IRRIGATION RESERVOIR  
SUBJECT TO STOCHASTIC INFLOWS

Pages in Study: 104

Candidate for the Degree of  
Doctor of Philosophy

Major Field: Agricultural Engineering

Scope and Method of Study: Management decisions related to crop/land/water allocations have been studied for a reservoir dependent irrigation district. The climate is sub-humid to semi-arid, and deficit irrigation is being practiced. Since the reservoir can accommodate over-year storage and is subject to stochastic inflows, a multi-year planning horizon is required. A single decision maker acts for the entire district. Three different models (hydrologic, crop growth and linear programming) are used within a dynamic programming framework. The crop growth and linear (economic) models identify feasible, optimum, intra-seasonal farm plans for various levels of water availability. Each farm plan consists of an allocation of crops to certain land units with certain irrigation strategies. The hydrologic model generates runoff estimates which are the reservoir inflows. The dynamic programming results enable one to identify the optimal inter-seasonal management decision for each of several initial reservoir levels. Multiple realizations of generated weather sequences incorporate the uncertainty in future weather. Probability-revenue curves are developed for various combinations of the initial reservoir level, the farm plan selected in the first year, and the planning horizon length. Although the overall modeling approach is appropriate for a variety of physical settings, herein it has been applied to a particular case study.

Findings and Conclusions: As expected, the use of a one-year planning horizon leads to the allocation of all available water in the reservoir. For a given planning horizon, as the initial water level in the reservoir increases, the multi-year revenues associated with various initial farm plans become more distinguishable. For a given initial reservoir level, these revenues become less distinct as the length of the planning horizon increases. Longer planning horizons allow more time to compensate for an incorrect (in hindsight) decision in year 1. For this particular case study, a very high discount factor was required to have any significant effect on the results. The proposed methodology opens new ways to quantitatively describe water release policies in a stochastic environment.

ADVISOR'S APPROVAL

Raymond T. Elliott

OPTIMIZING INTRA- AND INTER-SEASONAL WATER  
ALLOCATION FROM AN IRRIGATION RESERVOIR  
SUBJECT TO STOCHASTIC INFLOWS

Thesis Approved:

*Ronald L. Elliott*

\_\_\_\_\_  
Thesis Advisor

*C. Adair*

\_\_\_\_\_  
*Thomas M. Smith*

*Michael A. Kyz*

\_\_\_\_\_  
*M. P. Lenell*

\_\_\_\_\_  
Dean of the Graduate College

## ACKNOWLEDGEMENTS

My sincere thanks and acknowledgement to my major advisor Dr. R. L. Elliott, Regents Professor C. T. Haan, and Profs. M. P. Terrell, F. M. Epplin, and M. A. Kizer who have shown great interest and enthusiasm for this research from its onset. The guidance from all the Graduate Committee members through the difficult terrain of basic and applied science during this research has been especially appreciated.

I am grateful to the Agricultural Engineering Department for providing me with a graduate research assistantship during the entire Ph.D. study.

The constant encouragement from Emeritus Professors F. R. Moormann, from the University of Utrecht, The Netherlands and J. W. Pendleton from the University of Illinois at Urbana-Champaign, Illinois, USA, during and after my contract with the International Institute of Tropical Agriculture (I.I.T.A.) in Nigeria has been instrumental.

I especially wish to express my gratitude towards my and Amira's parents who have always encouraged their children to proceed in study as much as possible. I am very much indebted to my dear wife Amira and sons Egmond Samir and Stephan Christoffel who have shown patience and their indispensable support while enduring an interesting but hard time.

This list would not be complete without acknowledging the influence from Dr. & Mrs. E. H. Hartmans, who provided the opportunity to dive into real international dimensions at a crucial point in my studies.

I also appreciate the company of and conversations with my fellow students at the Department of Agricultural Engineering. The valuable input by Kareta Casey and Art Greene in preparing this document is highly acknowledged.

## TABLE OF CONTENTS

Chapter	Page
I. INTRODUCTION .....	1
Statement of the Problem .....	1
Overall Objective and Research Setting .....	3
II. REVIEW OF LITERATURE .....	5
Introduction .....	5
Hydrologic Models .....	6
Introduction .....	6
Deterministic Models .....	7
Stochastic Models .....	8
Selected Hydrologic Model .....	9
Crop Growth Simulation Models .....	9
Overview .....	9
Selected Crop Growth Simulation Model .....	13
Economic Risk Models .....	13
Introduction .....	13
Direct Applications of the Expected Utility Function .....	14
Risk Efficiency Analysis .....	15
Selected Economic Model .....	17
Optimization Techniques in Water	
Resources Planning .....	17
Introduction .....	17
Linear Programming (LP) .....	18
Dynamic Programming (DP) .....	19
Non-Linear Programming (NLP) .....	20
Simulation .....	21
Integrated Systems Analysis with Special Reference to the Reservoir-Irrigation Linkage .....	21

Chapter		Page
III.	DESCRIPTION OF THE SELECTED MODELS . . . . .	29
	Introduction . . . . .	29
	Hydrologic Model . . . . .	29
	Crop Growth Simulation Model . . . . .	36
	Economic Model . . . . .	37
	Dynamic Programming Model . . . . .	38
IV.	SOLUTION PROCEDURE AND MODEL LINKAGES . . . . .	41
	Overview of the Physical Setting . . . . .	41
	Hydrologic Model . . . . .	43
	Crop Growth Simulation Model . . . . .	43
	Economic Model . . . . .	45
	Dynamic Programming Model . . . . .	45
	Linkages between Model Components . . . . .	46
	Example Results . . . . .	48
V.	CASE STUDY RESULTS . . . . .	52
	Introduction . . . . .	52
	Hydrologic Model . . . . .	55
	Crop Growth Simulation Model . . . . .	56
	Economic Model . . . . .	59
	Dynamic Programming Model . . . . .	70
	Analysis of Output . . . . .	72
	Approach 1 . . . . .	74
	Approach 2 . . . . .	79
	Other Sensitivity Analyses . . . . .	85
VI.	SUMMARY AND CONCLUSIONS . . . . .	91
VII.	RECOMMENDATIONS FOR FURTHER RESEARCH . . . . .	95
	BIBLIOGRAPHY . . . . .	97



## LIST OF TABLES

Table	Page
1. General Form of the Linear Programming Tableau . . . . .	38
2. Feasible Farm Plans for Each Reservoir Zone . . . . .	70
3. DP Results regarding Farm Plans Selected for a 4-Year Planning Horizon (Single Simulation) . . . . .	73

## LIST OF FIGURES

Figure	Page
1. Schematic Diagram of the Conceptual Watershed System (PRMS) . . . . .	31
2. Flow-Plane and Channel Segment Delineation of a Basin (PRMS) . . . . .	32
3. General Form of a Serial Decision Problem . . . . .	40
4. The Physical Setting of the System under Consideration . . . . .	42
5. General Flowchart of the Proposed Methodology . . . . .	44
6. Example Calculation of Two Stages in a DP Program . . . . .	51
7. Location of Case Study Area and its Stations . . . . .	53
8. Observed and PRMS Predicted Runoff for a 6-Year Time Series (1957-1963) . . . . .	57
9. Location of Various Soil Units in Case Study Area . . . . .	58
10. Annual Rainfall Pattern Generated by EPIC . . . . .	60
11a. Simulated Grain Sorghum Yields (Clay Loam Soils) for Various Irrigation Strategies . . . . .	61
11b. Simulated Grain Sorghum Yields (Sandy Soils) for Various Irrigation Strategies . . . . .	62
11c. Simulated Grain Sorghum Yields (Sandy Loam Soils) for Various Irrigation Strategies . . . . .	63
12a. Simulated Cotton Yields (Clay Loam Soils) for Various Irrigation Strategies . . . . .	64
12b. Simulated Cotton Yields (Sandy Soils) for Various Irrigation Strategies . . . . .	65

Figure	Page
12c. Simulated Cotton Yields (Sandy Loam Soils) for Various Irrigation Strategies . . . . .	66
13. Altus Reservoir Elevation-Capacity Curve . . . . .	68
14. The Seven Alternative Intra-Seasonal Farm Plans . . . . .	69
15. Specification of Land/Crop/Water Allocation for each Identified Farm Plan . . . . .	71
16. Probabilities that the Feasible Farm Plans will be Optimum in Year 1 of a 1-Year Planning Horizon. Each Plot represents a different Initial Reservoir Level (Approach 1) . . . . .	76
17. Probabilities that the Feasible Farm Plans will be Optimum in Year 1 of a 3-Year Planning Horizon. Each Plot represents a different Initial Reservoir Level (Approach 1) . . . . .	77
18. Probabilities that the Feasible Farm Plans will be Optimum in Year 1 of a 5-Year Planning Horizon. Each Plot represents a different Initial Reservoir Level (Approach 1) . . . . .	77
19. Probabilities that the Feasible Farm Plans will be Optimum in Year 1 of a 10-Year Planning Horizon. Each Plot represents a different Initial Reservoir Level (Approach 1) . . . . .	78
20. Probabilities that the Feasible Farm Plans will be Optimum in Year 1 of a 20-Year Planning Horizon. Each Plot represents a different Initial Reservoir Level (Approach 1) . . . . .	78
21. Probability-Revenue Curves for a 3-Year Planning Horizon for Three Initial Reservoir Levels and Selected Farm Plans in the First Year (Approach 2, 0% Discount Factor) . . . . .	81
22. Probability-Revenue Curves for a 5-Year Planning Horizon for Three Initial Reservoir Levels and Selected Farm Plans in the First Year (Approach 2, 0% Discount Factor) . . . . .	82
23. Probability-Revenue Curves for a 10-Year Planning Horizon for Three Initial Reservoir Levels and Selected Farm Plans in the First Year (Approach 2, 0% Discount Factor) . . . . .	83

Figure	Page
24. Detailed Analysis of Probability-Revenue Curves for a 5-Year Planning Horizon for a Particular Initial Reservoir Level (Zone 1) and Selected Farm Plans in the First Year . . . . .	84
25. Probability-Revenue Curves for a 3-Year Planning Horizon for Three Initial Reservoir Levels and Selected Farm Plans in the First Year (Approach 2, 0% Discount Factor) . . . . .	87
26. Probability-Revenue Curves for a 3-Year Planning Horizon for Three Initial Reservoir Levels and Selected Farm Plans in the First Year (Approach 2, 60% Discount Factor) . . . . .	88
27. Probability-Revenue Curves for a 20-Year Planning Horizon for Three Initial Reservoir Levels and Selected Farm Plans in the First Year (Approach 2, 0% Discount Factor) . . . . .	89
28. Probability-Revenue Curves for a 20-Year Planning Horizon for Three Initial Reservoir Levels and Selected Farm Plans in the First Year (Approach 2, 60% Discount Factor) . . . . .	90

## CHAPTER I

### INTRODUCTION

#### Statement of the Problem

Irrigation projects which receive water from a reservoir can be difficult to manage. Annual fluctuations in runoff from the reservoir's catchment area can have considerable impact on the irrigation management strategy. Also many irrigation reservoirs serve other purposes including flood control, municipal and industrial water supply, and recreation.

The efficient allocation of reservoir water is a topic of both national (Moore, 1991) and international interest (Le Moigne et al., 1989; Higgins et al., 1988; Thanh and Biswas, 1990). In most irrigation districts under the management of the United States Bureau of Reclamation, which supplies irrigation water to about 4 million ha of cropland per year, the subsidized water price is a far cry from a shadow price (Moore, 1991). Tauer (1988) stated:

... there has been a surplus of engineering and biological efficiencies research and a shortage of economic efficiency studies. This perceived neglect has been rational because of the low marginal cost of water to farmers, either because of low energy costs or water prices not based upon full marginal costs.

With regard to irrigation water management practices, the American Society of Agricultural Engineers (1990) noted that greater emphasis can be expected on

developing comprehensive management strategies and technologies that provide long term solutions. An assessment by the United States Army Corps of Engineers (1990), a key national player in water supply, concluded:

"Recent droughts in the United States have caused water management agencies to examine the operation of their facilities to develop ways to improve their capability for providing water during times of short supply".

This study examined 516 reservoirs in the continental United States and suggested that computer simulation of reservoir operations during drought is the most effective way to determine how to use available storage to meet project purposes.

On the international scene, Higgins et al. (1988) mentioned:

"There is a general realization that many irrigation networks are failing in their fundamental function of delivering water, where and when it is needed, and in the right quantity."

Irrigation departments in many developing countries have been suffering financial setbacks and therefore operational management of these systems receives inadequate attention.

This topic is multidisciplinary in nature and therefore an integrated approach is necessary. Rogers and Fiering (1986) found in an extensive literature review that major progress in the various individual disciplines is not necessarily being applied to the "real world". The authors state the following as the main reasons: 1) institutional resistance; 2) deficiencies in data-bases; 3) the insensitivity of many models in changing operating conditions; 4) the relatively recent development of these models/techniques in comparison to the age of the newest large dams. These factors

contribute to the fact that there is only very limited application of integrated optimization models in modern reservoir operation in the USA and other countries. Integrated watershed-reservoir-irrigation models can serve to enhance the management of a limited resource.

### Overall Objective and Research Setting

The overall objective of the study was to develop an innovative and integrated method for optimizing intra-seasonal and inter-seasonal water allocations from a reservoir in a deficit irrigation situation. Various combinations of annual crops could be selected for the irrigated area. The goal was to maximize the net revenue obtained over a given multi-year planning horizon subject to certain physical constraints. The model was to be PC-based and capable of producing useful output for decision makers. A case study was included to test the approach used and to demonstrate its potential utility.

Many physical settings are possible for analyzing the problem of water allocation from a reservoir to an irrigated cropped area. In this particular research, the following physical characteristics are assumed:

- 1) a single-purpose irrigation reservoir is operated in a sub-humid to semi-arid climate, and a reasonably sized catchment area supplies the irrigation reservoir with runoff water;
- 2) both water demand and water supply may vary over time (intra- and inter-seasonally);
- 3) the frequency with which droughts occur is high enough to require water to be

stored in reservoirs for more than one year (over-year storage);

4) land suitable for irrigation is plentiful in relation to the available water and has relatively low value in alternative non-irrigation uses, thus encouraging the practice of deficit irrigation;

5) the irrigable land area can be divided into a number of reasonably sized homogeneous units; and

6) a single decision maker (e.g., a board or other public entity) manages reservoir releases for a relatively large irrigated area (perhaps 10,000 to 100,000 ha).



## CHAPTER II

### REVIEW OF LITERATURE

#### Introduction

The modeling approach proposed in this study draws on a diverse body of literature. The problem outlined covers a range of topics including hydrology, crop growth simulation, economics and optimization.

Although many of the individual problems in this research setting have already been resolved in a satisfactory manner by researchers, the linkages and relationships among the system components are often not easily visible and/or readily quantifiable. Scientific advances and enhanced computer capability have made it possible to address the problem in a more holistic manner.

The literature review is divided into five sections:

- 1) hydrologic models;
- 2) crop growth simulation models;
- 3) economic risk models;
- 4) optimization techniques in water resources planning; and
- 5) integrated systems analysis with special reference to the reservoir-irrigation linkage. The first four sections of the literature review consider the models or techniques in a stand-alone fashion. The fifth section encompasses references which

combine two or more of the individual models or techniques.

## Hydrologic Models

### Introduction

Hydrology is a very broad field of science and a wide variety of modeling approaches are used. In categorizing hydrologic models, Singh (1988) refers to the physical science approach and the systems approach. The physical science approach synthesizes the hydrologic processes and describes them in mathematical relationships. The systems approach bypasses much of the complexity involved in the physical science approach and, as a result, its predictive capability is often much less.

Objective methods of choosing or defining the "best" model have not yet been developed. Dooge (1972) approached the selection of a hydrologic model through the following steps: 1) clearly define the problem; 2) specify the objective; 3) study the data availability; 4) determine the computing facilities available; 5) specify the economic and social constraints; and 6) choose a particular class of hydrologic models.

For the current study, the selected model should provide information on runoff from a particular area based on a specified rainfall pattern. A continuous record of runoff predictions is needed rather than event-based runoff estimates. Two general types of models can produce this continuous record of runoff. Deterministic models tend to reflect the physical science approach and stochastic models the systems approach.

## Deterministic Models

A deterministic streamflow model converts a precipitation time series into a runoff time series using physically based relationships. Any change in physical parameters can easily be incorporated in the rainfall-runoff model. Deterministic modeling has three major advantages (Singh, 1988): 1) the response function can be developed directly from the input parameters if an appropriate model is used; 2) non-uniform storms may be applied to the basin; and 3) the change in basin response resulting from man-made changes over the basin may be assessed.

For deterministic models, a distinction can be made between distributed parameter and lumped parameter models (Viessman et al., 1989). A distributed parameter model requires detailed data on the physical characteristics of the catchment area. A lumped parameter model generalizes this location specific information to a lumped or averaged set of parameters. It involves a grey or black box approach where the physical relationships among the different parameters or components of the hydrologic setting are less prominent (Singh, 1988).

One of the most widely used deterministic rainfall-runoff models in the United States is the Stanford Watershed Model (SWM) developed by Crawford and Linsley (1963). Many variants of this model have also appeared. The SWM model consists of a sequence of computation routines for each process in the hydrologic cycle. This model produces a continuous hydrograph of hourly or daily streamflows at a certain location in the catchment area. A lumped parameter approach is used and consequently data requirements are much less than for distributed models (Viessman et al., 1989).

Many other deterministic models exist, developed by different agencies and used for different purposes. Examples are the Kentucky Watershed Model, the Ohio State University Model (OSUM), the National Weather Service River Forecast System (NWSRFS) and the Tennessee Valley Authority (TVA) model (Singh, 1988).

Comprehensive overviews of the major models up to 1982 (Haan et al., 1982) and up to 1988 (Singh, 1988) document the wide variety of available models. No major new techniques or approaches have been developed since the emergence of the more recent models in the 1980's. Newer models are still based on the principle of physical component description. The differences in the models primarily reflect mathematical solution procedures or particular physical settings to be addressed.

#### Stochastic Models

Stochastic models employ a systems oriented approach rather than a physical science approach. A stochastic model is based upon parameters selected from historical streamflow data. The parameters themselves are functions of random variables and only depend on the streamflow data series. Other characteristics of the area under consideration are not directly taken into account. A stochastic model is more restricted in its use than a deterministic model (Haan, 1977). Changes in physical conditions in specific locations of the catchment area are difficult to include or specify in a stochastic model. However, data requirements are considerably less than those for the deterministic models. Within the category of stochastic models, distinction can be made between autoregressive, fractional Gaussian noise, autoregressive and moving average, broken line ARMA-Markov and shifting level

models (Salas and Smith, 1981). Haan et al. (1982) summarize the theory behind most of these techniques which use information from historical streamflows.

A review by Yevjevich (1987) indicated that stochastic modeling has begun to incorporate more physical (deterministic) parameters than in the past. Thus, in future research efforts, one may see more approaches which try to merge these two, quite distinctive techniques.

#### Selected Hydrologic Model

Given the requirements of the overall modeling approach, preference needs to be given to physically based models which provide a continuous simulation of runoff. One of the models which meets these criteria is the P(recipitation) R(unoff) M(odelling) S(ystem) developed by the United States Geological Survey (Leavesley et al., 1983). PRMS is described as a modular, deterministic, distributed-parameter model. This model allows one to evaluate impacts of precipitation, climate, and land use on streamflow, sediment yields and general basin hydrology. Because of the distributed parameter approach, the quantity of input data exceeds that of the lumped parameter models like SWM. PRMS provides both parameter optimization and sensitivity analysis within the model.

#### Crop Growth Simulation Models

##### Overview

An important aspect of irrigation water management is the interaction among soil, water and atmospheric parameters. As a result, considerable research effort has

gone into development of crop growth simulation models. These models can be useful tools for studying the relationship between water application and crop production.

Jensen et al. (1990) state that the effects of irrigation on crop production must be accurately predicted to permit economic analysis of irrigation systems, irrigation management and water resources allocation decisions. As the development of comprehensive crop growth models increases, the irrigation economic analyses and real time irrigation decisions can be accomplished with expert systems that rely on crop simulation.

Until the mid 1970's, yield-water relationships for crops were largely based on statistically estimated production functions obtained from field experiments. The timing and applied quantities of irrigation water were varied and general conclusions drawn for specific physiographic areas. These assessments were made for each crop of interest. A generalized yield-water production function may give some indication of expected yield, but the approach is usually not sensitive to such factors as soil type, tillage practices and cultivar grown.

Hexem and Heady (1978) presented an overview of water production functions for irrigated agriculture based on a number of controlled experiments in the western part of the United States. These production functions were a step forward in the development of simple yield-water relationships. The authors acknowledged several limitations in the derived functions, including the difficulty in separating water from other factors affecting crop yield. These response functions also did not consider the time of application and consequently were not dynamic. The authors suggested that in time simulation models would become a useful tool in establishing the desired

relationships.

Doorenbos and Kassam (1979) used empirical data from many different countries, translated or reduced the set of variables to only a few and tried to derive a simple mathematical relationship between water availability and crop yield. A relative yield decrease and a relative evapotranspiration deficit were linked through an empirically based yield response factor. This approach could be considered semi-quantitative and a step forward from statistically estimated water-yield relationships.

Ahmed et al. (1976) presented another approach for simulating water use and crop response. They developed a simulation program which was based on four agronomic principles:

- 1) the growth of a crop depends on the irrigation strategy itself;
- 2) the crop water use is not independent of soil moisture conditions in the rootzone;
- 3) the crop yield reduction due to water deficit depends not only on the magnitude of the deficit but also on the crop growth stage at the time of deficit; and
- 4) the crop responds directly to the plant-water condition.

Until the early 1980's, yield-water relationships were rather empirical and site specific. These relationships, which have been called first generation models (Geigel and Sundquist, 1984), use average values for discrete time periods (months or seasons), based upon historical data for specific geographical areas. The yield equation is in a simple algebraic form. First generation models tend to be spatially oriented on a state or crop reporting district level.

By including more physical parameters in the model, first generation models convert into second generation models (Geigel and Sundquist, 1984). These models

are characterized by daily or weekly input data derived from surveys or field experiments. The yield estimation is still in a rather simple algebraic form. Physiological aspects are recognized to a greater extent and soils data are more detailed. In general the second generation models are more accurate and versatile, but access to sufficiently accurate and location-specific data might be a constraint.

In the mid 1980's the so-called third generation models emerged (Geigel and Sundquist, 1984). More detailed than earlier models, these models describe plant growth and other developmental processes more precisely through functional relationships. In many cases the needed data (daily) are obtained from controlled experiments designed specifically for that purpose. The yield equation can be simple or complicated in nature. An overview of these third generation models is presented by Jones and Ritchie (1990). Many models are specifically developed for one particular crop. CERES-Maize (Ritchie et al., 1989), SOYGRO (Jones et al., 1989) and PNUTGRO (Boote et al., 1989) are a few examples. These models are so-called user-oriented crop growth models which are tested over a range of conditions, can be operated with readily available data and are relatively well documented.

Validation of third generation models requires special attention (Whisler et al., 1986) and can be a tedious exercise. Validation can be defined as the comparison of the predictions of a verified model with experimental observations other than those used to build and calibrate the model. Sensitivity or uncertainty analysis involves changing one particular parameter in the model and holding all others constant. The outcome will reflect the influence of this changed parameter on the end result.



### Selected Crop Growth Simulation Model

For planning or evaluation studies, it can be very useful to have access to crop models which can address different crops within the same modeling framework. Examples are DSSAT and EPIC. DSSAT (IBSNAT, 1989) is a user-oriented software package which includes the capability to evaluate irrigation management strategies for various crops and selected soils, sites, planting dates and other factors. This program includes crop growth models for wheat (CERES-Wheat), corn (CERES-Maize), soybean (SOYGRO) and peanut (PNUTGRO).

EPIC (Erosion Productivity Impact Calculator) is a user-oriented, mathematical model for simulating erosion, crop production and related processes using daily time steps and readily available inputs (Williams et al., 1984; Williams and Renard, 1985; Williams, 1983). EPIC is composed of physically based components including weather, hydrology, erosion, sedimentation, nutrients, plant growth, tillage, soil temperature, economics and plant environment control. EPIC can be applied to a wide range of soils, climates and crops and is the selected model for this study.

### Economic Risk Models

#### Introduction

Economic models can be used as tools in helping decision makers. It seems that the words "agriculture" and "risk" go hand-in-hand. One of the uncertain driving forces in many agriculturally related processes is weather. It is difficult to analyze the effects of weather conditions on crop production in a time and space dependent

setting. For this and other reasons, risk analysis is an important part of economic analysis. Risk analysis is an extensive area of research within the agricultural economics discipline and many different methods exist for studying risk-associated decisions in farming.

According to Hazell and Norton (1986):

"Ignoring risk-averse behavior in farm planning models often leads to results that are unacceptable to the farmer, or that bear little relation to the decision he actually makes".

The development of linear programming and associated techniques opened up risk analysis as an area of specialization. One of the earliest studies addressing risky agricultural decisions was by Freund (1956).

Boisvert and McCarl (1990) divided the risk analysis models into two major groups: 1) models which are direct applications of expected utility theory and attempt to identify a single optimal decision given the utility function; and 2) models which are consistent with expected utility maximization but which identify "efficient" portfolios of decision alternatives (risk efficiency analysis).

#### Direct Applications of the Expected Utility Function

An expected utility function (Hazell and Norton, 1986) defines how an individual ought to order risky prospects. An individual's utility function can have any particular functional form. The choice of a functional form reflects the risk preference of the individual. Given any two farm plans  $X_1$  and  $X_2$ , this theory predicts  $X_1$  will be preferred over  $X_2$  only if  $E[U(Y_1)] \geq E[U(Y_2)]$  where  $E$  represents the expected value

and  $U(Y)$  is utility as a function of income. This utility function is a mathematical device to assign numerical utility values to the consequences in a way that is consistent with the decision maker's preference. In other words,  $X_1$  is preferred over  $X_2$  if the expected (or average) value of utility over all possible incomes is larger for  $X_1$  than for  $X_2$ .

### Risk Efficiency Analysis

Instead of identifying one particular solution, some economic models develop sets of efficient solutions. In this case the full specification of the utility function is not necessary. Risk efficiency analysis involves imposing restrictions on utility functions and/or the probability distributions of the choice set (Curtis et al., 1987).

One of the most widely used risk efficiency analyses is based on Mean-Variance (E-V) Analysis (Boisvert and McCarl, 1990). The underlying assumption here is that given any two distributions with equal means, a decision maker who is risk averse will prefer the distribution with the smallest variance. The efficient E-V set can be obtained by minimizing the variance for each possible level of expected income while still meeting the available resource constraints. Quadratic programming techniques can be used for the selection of efficient E-V farm plans. This method was developed by Markowitz (1952) for the selection of portfolios of assets. E-V analysis may lead to unwarranted conclusions when the assumptions of normality or a quadratic utility are violated.

The linear programming alternative for the E-V analysis is the one developed by Hazell (1971) and called MOTAD. M(inimization) O(f) T(otal) A(bsolute)

D(eviation) is most relevant when the variance of farm income is estimated using time series sample data. The MOTAD model leads to a linear rather than a quadratic programming model. It uses variance estimates based on the sample Mean Absolute Deviation (Hazell and Norton, 1986).

Another technique of risk efficiency analysis is the stochastic dominance theory (Zentner et al., 1981; Boisvert and McCarl, 1990). This theory provides a means of selecting alternatives that are optimal according to expected utility maximization for a specified set of utility functions. It involves pairwise comparisons of cumulative distribution functions of net return which are based on different strategies. First and second degree stochastic dominance form the main sets for this particular technique. Stochastic dominance theory places only a few restrictions on the utility function and none on the probability function. This particular method is not directly programmable and no techniques have been developed to select dominant plans from individual activities (Tauer, 1983). First, feasible sets of solutions need to be generated and subsequently the stochastic dominance theory applied in order to select efficient plans.

Other methods of risk efficiency analysis include MEAN-GINI and TARGET-MOTAD (Boisvert and McCarl, 1990). Both methods can be applied using a linear programming technique. The MEAN-GINI method was developed by Yitzhaki (1982) and is based on mean income and Gini's mean absolute difference as a measure of income distribution. In TARGET-MOTAD (Hazell and Norton, 1986) the expression TARGET stands for a specific monetary target set. This model contains two parameters: a target value and the lambda value ( $\lambda$ ) which is the accumulated amount

of the deviation from that target over a certain time series of economic data (expressed in monetary terms). Only negative deviations from that target are taken into account. This TARGET-MOTAD model can be solved for the solution which maximizes income subject to the resource constraints and target income constraints.

### Selected Economic Model

The model which was selected represents a simplification of the TARGET-MOTAD principle. TARGET-MOTAD can be used for risk related analysis, but it also can be used for straight-forward expected values. One of the drawbacks of TARGET-MOTAD is that a multitude of solutions need to be screened. However, objective selection criteria are difficult to develop. Therefore, in this study the direct linear programming solutions from the TARGET-MOTAD model are used.

## Optimization Techniques in Water Resources Planning

### Introduction

Rogers and Fiering (1986) stated :

"Over the past 30 years systems analysis applied to the planning and operation of water resource systems has grown from a mathematical curiosity to a major specialty."

Systems analysis can be defined as that set of mathematical planning and design techniques which includes at least some formal optimization procedure. Systems analysis in water resources planning has until recently been based upon solving individual problems that are actually part of a broader setting. Only one particular or

a small set of parameters or subsystems were being optimized. Other components of the larger system were either assumed constant or simply ignored. More holistic approaches have been difficult to implement because of the many complicated inter-relationships of the water balance.

A number of techniques can be used in systems analysis with special reference to water planning. Yeh (1985) divides the optimization techniques into four categories:

- 1) Linear Programming (LP);
- 2) Dynamic Programming (DP);
- 3) Non-Linear Programming (NLP); and
- 4) Simulation.

A fifth category could be added, comprised of those models which combine any of the above four techniques.

#### Linear Programming (LP)

With LP, an objective function is either to be maximized or minimized subject to a number of constraints. Both the objective function and constraints must be in a linear form thus assuring that there will be no local optima in the policy space (i.e., convexity is achieved). One advantage of LP techniques is that existing computer software packages can be used. The linear program is solved by the simplex technique, an iterative procedure whereby a systematic "scanning" of a finite number of cornerpoints in the convex policy space finds a global optimum. Yaron and Dinar (1982), Boman and Hill (1989), and Matanga and Marino (1979) used LP to obtain

solutions for specific water resource settings.

### Dynamic Programming (DP)

DP is a mathematical procedure designed primarily to improve the computational efficiency of select mathematical programming problems by decomposition into smaller, and hence computationally simpler, subproblems. In principle DP is capable of handling nonlinear and stochastic reservoir problems. Computer algorithms are commonly custom written rather than standardized as in LP. DP is a technique developed by Bellman (1957) which solves the entire problem in a sequential fashion in stages, with each stage involving exactly one optimizing variable. Through recursive equations these computations at different stages are interlinked and finally yield a feasible optimal solution to the entire problem. This sequential optimization technique fits very well with the procedures and processes involved in reservoir operations.

An extensive review (Yakowitz, 1982) of dynamic programming applications in water resources revealed that:

An unmistakable conclusion is that water resource problems serve as an excellent impetus and laboratory for dynamic programming developments; conversely, progress in making dynamic programming applications in water resources economically viable depends on further advances in theoretical and numerical aspects of dynamic programming. At the present time the influence of dynamic programming on water resource practice is modest.

Two important terms in DP are stage and state. A stage is defined as the portion of the problem that possesses a set of mutually exclusive alternatives from which the best alternative is to be selected. The state of the system represents the

"link" between succeeding stages so that when each stage is optimized separately, the resulting decision is automatically feasible for the entire problem. In reservoir related DP, stages could represent different time periods (i.e., weeks, months, years) while states could represent reservoir storage (i.e., 50% full, 75% full). However, there is a serious limitation in the number of states which can be included. At the present time, the practical maximum number of state variables seems to be two to four. This constraint is called the "Curse of Dimensionality". The dimensionality problem has been addressed in a variety of ways:

- 1) State Incremental Dynamic Programming (Mawer and Thorn, 1974; Nopmonggol and Askew, 1976);
- 2) Discrete Differential Dynamic Programming (Heidari et al., 1971);
- 3) Constrained Differential Dynamic Programming (Murray and Yakowitz, 1979);
- 4) Progressive Optimality Algorithm (Turgeon, 1981);
- 5) Binary State Dynamic Programming (Ozden, 1984);
- 6) Gradient Dynamic Programming (Foufoula-Georgiou, 1991; Foufoula-Georgiou and Kitanidis, 1988); and
- 7) Aggregate State Dynamic Programming (Stillwater, 1990).

Each of these methods employs approximation algorithms in which the user needs to specify a certain initial solution.

#### Non-Linear Programming (NLP)

According to Benedini (1988) and Yeh (1985), there have been a few applications of non-linear optimization in water resources. Unlike LP, there is no



general algorithm for solving non-linear problems (Orth, 1986). Furthermore the policy space might not be convex which causes difficulties in finding the global optimum. In the majority of cases the focus of the problem is on transforming nonlinearities into expressions which are computationally easier to handle. NLP has not been widely used in water resources systems analysis, perhaps because the optimization procedure itself is slow and the requirements for computer storage and time are substantial. Two examples are Gagnon et al. (1974) and Hanscom et al. (1980).

### Simulation

Yeh (1985) defines simulation as follows:

"Simulation is a modeling technique that is used to approximate the behavior of a system on the computer, repeating all the characteristics of the system largely by a mathematical or algebraic descriptor".

Simulation modeling has been used many times, either as the sole technique or as a component part of a larger systems analysis exercise (Hall and Dracup, 1970; Dudley et al., 1971a, 1971b; Dudley et al., 1972; Dudley, 1972; Yaron et al., 1973; Ahmed et al., 1976).

### Integrated Systems Analysis with Special Reference to the Reservoir-Irrigation Linkage

Irrigation projects connected to surface water reservoirs have been developed in many countries to increase food production. Although these projects came

gradually into place, management was (and is) a main concern for the agencies and organizations in charge of deciding on land/crop/water allocations for the irrigated areas. Large irrigation schemes are commonly operated by a single decision maker (e.g., a planning or water board). Dudley (1988) recognized that:

The single decision maker acting despotically can make the best economic decisions and achieve a level of expected annual benefits from a given area developed for irrigation which cannot be matched by multiple decision makers acting independently.

Also Vedula and Mujumdar (1992) stressed that in this type of setting only a single decision maker is in a position to make optimal decisions.

Yeh (1985) gives a state-of-the-art review of the various techniques which have been used in modeling reservoir management and operation. The author comes to the conclusion that:

During the last 20 years, one of the most important advances in the field of water resources engineering is the development and adoption of optimization techniques for planning, design and management of complex water resources systems. Complex water resources systems involve thousands of decision variables and constraints.

One of the first attempts to address irrigation reservoir management with a holistic approach was by Dudley (1969). The author was concerned with the general problem of maximizing the expected value of net benefits from irrigation possibly by regulating the flow of a river with a dam. This study used a combination of simulation and dynamic programming.

Jenson (1971) developed a systematic approach to the management of a watershed by integrating supply and demand. This study was conducted with the Bureau of Reclamation.

Publications by Dudley (1972) and Dudley et al. (1971a, 1971b, 1972)

presented a method of inter- and intra-seasonal water and land allocation for one crop through a four-step procedure. A two-state, stochastic dynamic program was used to derive optimal irrigation amounts and timing under a limited seasonal water supply. The planning horizon was divided into short-run, intermediate-run and long-run components.

In the short run, a plant growth/soil moisture model was incorporated into a two-state stochastic DP. The crop area was fixed and rainfall and crop water requirements were stochastic. The state variables were soil water content and irrigation reservoir level. Associated transition probabilities of soil moisture were obtained through simulation.

The intermediate decision was the area of crops to be planted at the beginning of the season. A simple crop growth model was used with stochastic crop water requirements. The solutions for the short-run problems were used.

In the long run, a decision was made on the best size of irrigation area for a given reservoir. Short- and intermediate-run results were incorporated.

Dudley (1972) noted that one shortcoming of his approach was that the water at the end of the season had zero value. He adjusted the original model by taking the value of water in future seasons into account when selecting irrigated acreages at the start of the season and the irrigation policies during the season.

Yaron et al. (1973) presented an approach for irrigation decision making under conditions of unstable rainfall. A simulation model was used to track soil moisture during the season.

Horowitz's (1974) research was based on the Bureau of Reclamation's desire

to improve methods of determining economic returns on irrigated land. His work was divided into two parts: 1) development of irrigation production functions from a theoretical and experimental point of view; and 2) application of programming techniques (mainly LP) to determine optimal allocation of water within multiple purpose water development projects with special emphasis on irrigation.

Blank (1975) used a combination of dynamic and linear programming to determine optimal amounts of irrigation at pre-scheduled times for a single crop. The study did not incorporate a reservoir but did include various crops, multiple time periods and random precipitation. The problem was first solved with abundant water at a predetermined price and then the same sequence was performed with limited water. The model was run with two different objective functions: 1) profit maximization (not yield maximization), and 2) minimization of variance due to random precipitation.

In Dudley et al. (1976), a hierarchy of models was developed to aid management and planning decisions in multicrop water resources systems located in higher latitudes of the world and featuring significant downstream requirements. A major objective was to quantify trade-offs between systems with a highly reliable water supply but low average benefits and those with low reliability but high average benefits. A combination of LP, simulation and DP was employed. LP was used to select best crop combinations for given quantities of water available over the summer and to determine the associated water usage and revenue estimates. A simulation model predicted changes in reservoir storage resulting from inflows and releases to meet requirements of crops selected by the LP. Interseasonal water allocation was

then optimized by using DP. Multiple crops were considered but, in contrast to Dudley (1972), demands were assumed deterministic.

Cordova and Bras (1979) addressed the problem of scheduling deficit irrigation. Their model used soil moisture and available irrigation water as state variables in stochastic dynamic programming. Transition probabilities for soil moisture were analytically obtained in contrast to Dudley et al. (1971a, 1971b) where they were obtained through simulation.

Bras and Cordova (1981) treated water demand as a stochastic variable (random rainfall, deterministic potential evapotranspiration), but water supply as deterministic in an approach featuring analytical derivations of soil water transition probabilities. The study considered a single crop and a one-year planning horizon with a known volume of water available at the beginning of the season. The DP algorithm determined the optimal control policy at each irrigation decision point based on the state of the system (soil moisture content).

Rhenals and Bras (1981) treated demand as stochastic (random potential evapotranspiration) but supply as deterministic in a study of intraseasonal water allocation. A stochastic DP was formulated to maximize net benefits from a crop facing uncertain, correlated evapotranspiration demands. Weekly irrigation decisions were made after observing current soil moisture and available irrigation water, as well as potential evapotranspiration in the past week.

Through the 1970's and into the early 1980's, most of the systems analysis focused on soil-water-plant-atmosphere relationships, as opposed to reservoir management. In state-of-the-art reviews of DP applications in water resources

(Yakowitz, 1982), and reservoir management and operation models (Yeh, 1985), it was acknowledged that there existed no general algorithm for the solution of reservoir optimization problems.

Yaron and Dinar (1982) presented a systems analysis approach whereby scarce water is allocated during peak seasons to alternative crops and plots, using soil moisture response functions for the key crops. The approach incorporated a LP model for maximizing the farm's income, and a DP for generating new irrigation scheduling activities in response to the shadow price of water given by the LP solutions. The method was based on decomposition and LP-DP iterations; weather conditions were assumed to be known with certainty.

Martin (1984) suggested that seasonal irrigation scheduling requires a combination of both simulation and optimization. The author also noted that irrigation system characteristics are often not included in optimization studies.

Tsakiris and Kiountouzis (1984) used a DP model to optimize the intra-seasonal distribution of irrigation water to a single crop under the constraints of limited water availability and predetermined irrigation timing. In a deterministic, two-state, DP model, the irrigation amount was used as a stage of the model. The two states were the available soil water in the crop root zone and the net quantity of water to be transferred to the root zone. No reservoir component was included.

Progress was made in modeling irrigation allocation decisions when simple crop yield production functions began to be replaced by more sophisticated crop growth models. This allowed for refinement in describing yield-water relationships.

Dudley (1988) extended his earlier work by incorporating a sophisticated plant

growth simulation model. A model was developed for optimizing short, intermediate and long term irrigation decisions for surface water reservoirs in a river-valley irrigation system controlled by one decision maker. Highly variable reservoir inflows and plentiful irrigable land in relation to available water were the main characteristics of the modeled valley. Dudley stated:

The assumption of one decision maker internalizes the derivation and communication of supply and demand probabilities, giving the results a level of economic efficiency which makes them a standard against which to judge the results of decentralized models.

Furthermore Dudley noted in this work that:

"Although there have been many published studies of reservoir management and operation models, there appear to be very few which use stochastic components in both supply and demand for water in the model."

Darlane (1989) stated that:

"An irrigation reservoir operation policy should reflect the economic value of stored versus released water".

The author developed an intra-seasonal water release policy based on certain reservoir decision rules.

Rao et al. (1990) addressed the problem of allocation of a limited water supply for irrigation of several crops grown in the same season. Both seasonal and intra-seasonal competition for water between crops were considered. The allocation problem was solved in a dynamic framework by decomposition to two levels (seasonal and intra-seasonal). A single crop model provided the input to the models at both levels. The optimization models at the two levels and the single crop level were solved by DP. Economic coefficients, crop areas, and crop growth stage stress effects

were included in the mathematical formulation at both levels. A set of weekly irrigation programs for individual crops was the output from the model.

Paudyal and Das Gupta (1990) used multilevel LP to decide which major irrigation facilities should be built, what crops should be grown, and how to manage the system operation to make the most effective use of the natural resources. The irrigation management model had a one year planning horizon. The approach was used to optimize the cropping pattern in various subareas of the basin, the design capacities of irrigation facilities (including both surface and ground water resources), and the water allocation policies for a conjunctive use.

Lee et al. (1991) addressed the dynamic irrigation scheduling problem with stochastic weather data by using the Markov process, a crop growth model and DP. Several stochastic optimization models of different complexity were formulated. A simple one-stage or one-day decision model was also formulated, based on certain simplifying assumptions. The reservoir component was not taken into account.

Vedula and Mujumdar (1992) used stochastic DP to develop an optimal operating policy for an irrigation reservoir and a multiple crops scenario. Intra-seasonal periods smaller than the crop growth stage durations formed the decision variables of the model. Reservoir storage, inflow to the reservoir, and the soil moisture in the irrigated area were treated as state variables. Rainfall and evapotranspiration were treated deterministically in computing the irrigation applications to various crops. An optimal allocation process was incorporated in the model to determine water allocations to competing crops.



## CHAPTER III

### DESCRIPTION OF THE SELECTED MODELS

#### Introduction

The methodology developed in this research involves four component models:

- a) hydrologic model;
- b) crop growth simulation model;
- c) economic model; and
- d) dynamic programming model.

In this chapter, each of the selected models is described and discussed.

#### Hydrologic Model

The hydrologic model selected is P(recipitation) R(unoff) M(odelling) S(ystem). It was developed by the U. S. Geological Survey with the first version released in 1983 (Leavesley et al.). This rainfall-runoff model is a deterministic, distributed parameter, modeling system developed to evaluate the impact of weather and land use on stream flow, sediment yield and general basin hydrology.

The PRMS program has a modular design. Each component of the hydrologic system is described by one or more FORTRAN subroutines that are maintained in a system library. The library also contains subroutines for parameter optimization,

sensitivity analysis and output handling and analysis. The PRMS structure also accommodates the manipulation and storage of hydrologic and meteorologic data. The model can be used both as a management tool and a research tool.

PRMS simulates both mean daily flows and storm flow hydrographs. The total watershed system is conceptualized as a series of reservoirs called the impervious zone reservoir, soil zone reservoir, subsurface reservoir and groundwater reservoir (Figure 1). PRMS's principle of modeling is based upon partitioning of the watershed into hydrologic response units (HRU's). Each unit is considered to be homogeneous with respect to its hydrologic response (Figure 2), based on such factors as vegetative cover, slopes, soils, etc. A water balance and an energy balance are computed daily for each HRU. A maximum of 50 HRU's can be handled by the program. The number and location of HRU's to be assigned are a function of the physiographic complexity of the watershed area, input data availability (both in time and space) and the problem to be addressed by the model.

There is no restriction on catchment area size and HRU size. The model has been used for catchment areas varying in size from a few km<sup>2</sup> to more than 2000 km<sup>2</sup> (personal communication with L. G. Saindon of the USGS in Denver, Colorado, one of the developers of PRMS). The required input variables include data on the physiography, vegetation, soils and hydrologic characteristics of each HRU, and if applicable on the variation of climate (temperature, precipitation, solar radiation, etc.) over the watershed. The required formats for the meteorological and streamflow data are compatible with those used in the U. S. Geological Survey's National Water Data Storage and Retrieval (WATSTORE) system.

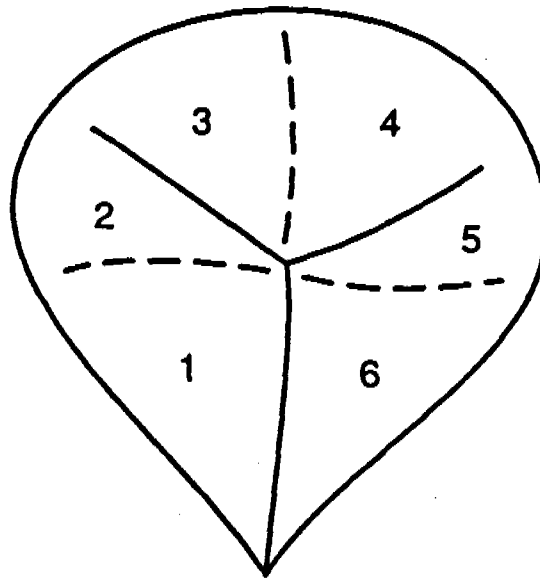

### Hydrologic-Response Unit Delineation

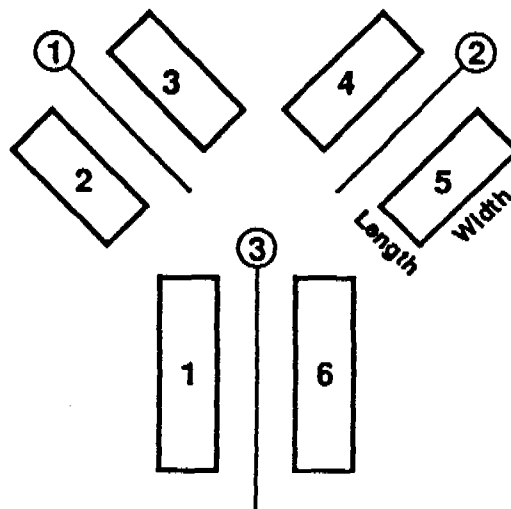

#### Explanation

- ③ — Channel segment number
- 3 — Flow-plane and number

Figure 2. Flow-Plane and Channel Segment Delineation of a Basin (PRMS)

With precipitation patterns that are highly variable in space, a decision needs to be made on matching these patterns to the HRU's. Rainfall data from multiple stations can be aggregated as appropriate. When rainfall data are available from one station only, they need to be evaluated as to their representativeness of the larger area.

Streamflow data should be acquired for one or more locations within the watershed. The presence of more than one streamgage station in a catchment area allows one to compensate for missing records or the influence of flood routing between the two catchment area sections. Sometimes regional analysis of both rainfall and streamgage data can supplement the existing records from that part of the catchment area under investigation.

Data on physiography of the area, vegetation, soils and hydrologic characteristics of the HRU's can be retrieved from topographic maps, soil surveys, GIS data-bases, aerial photographs and other inventory studies. Watershed parameters can be refined through an optimization which compares an observed runoff sequence to the simulated runoff sequence.

Since the maximum span for optimization with daily streamflow data is approximately six years, a long historical record needs to be optimized a number of times. It was shown by Allred and Haan (1991) that the observed record length influences the variability of optimized parameters.

Once the optimization procedure has come to an optimized set of parameters for the particular watershed and hydrometeorological conditions, that set is then used to simulate the effect of rainfall time series on the watershed. The minimum driving

variables required to run in the daily flow mode are daily precipitation and maximum and minimum daily air temperature.

A three-tier approach is used to produce a reliable rainfall-runoff relationship:

- 1] Start with assumed values for all the parameters for which no "hard" data are available.
  - 2] Run the model with the estimated parameters and evaluate the objective function value which represents the difference between the daily predicted and observed runoff. This difference can be expressed as the sum of the absolute deviations or the sum of the squared deviations. Observing the difference (either on a monthly or seasonal basis) can give an indication of which parameters to adjust.
  - 3] Find a suitable match using the optimization procedure and a sensitivity analysis which determines the stability of the solution for certain changes in parameters.
- However, it is not possible to optimize a large number of parameters simultaneously. Many parameters exhibit interactions. After that subjective match has been identified, all parameters should be left constant for the subsequent runs of the model.

The total data requirement for PRMS has been divided into seven different files. Each file contains the specifications of parameters needed to implement certain scenarios. A daily-flow simulation will require fewer files than a storm-event simulation. Following are short descriptions of the seven files:

1) Parameter and Variable Initialization:

This file is needed for all simulation runs; simulation options, types of hydrologic and meteorological input data and output options are specified. Furthermore model parameters are initialized and the physical characteristics of the hydrologic response

units (HRU's) are established.

**2) Storm Period Selection:**

This file is needed only if the simulations are conducted in a storm period mode. A storm period is defined as one or more days of storm rainfall.

**3) Infiltration/Upland Erosion Parameters:**

This file defines infiltration and erosion characteristics of an HRU for storm mode computations.

**4) Flow and Sediment Routing Specifications:**

This file specifies the type and flow characteristics of the overland flow planes, and channel, reservoir and junction segments into which the entire basin has been subdivided.

**5) Precipitation Form Adjustment:**

This file indicates whether daily precipitation is in the form of snow or rain.

**6) Snowpack Adjustment:**

This file specifies the snowpack water equivalents on each HRU.

**7) Optimization or Sensitivity Analysis Data:**

This file includes data on the type of optimization and the parameters for sensitivity analysis.

Within PRMS, a weather generator can be used to produce a new time series based on historical data. The weather data and model parameters are used to deterministically calculate a runoff series based on a given time series of rainfall.

## Crop Growth Simulation Model

The crop growth simulation model used in this research is E(rosion) P(roductivity) I(mpact) C(alculator). EPIC is composed of physically-based components for simulating erosion, plant growth, and related processes using daily time steps. The components of EPIC can be placed into nine major divisions: hydrology, weather, erosion, nutrients, plant growth, soil temperature, tillage, economics and plant environmental control. The weather variables for driving EPIC are precipitation, air temperature and solar radiation.

EPIC has a built-in weather generator which can simulate temperature and radiation given daily rainfall or simulate rainfall in addition to temperature and radiation. The precipitation component in EPIC is a first-order Markov-chain model. Thus, the model must be provided as input monthly probabilities of receiving precipitation for two conditions: a) precipitation occurred on the previous day, and b) no precipitation on the previous day. Given the initial wet-dry start, the model determines stochastically whether or not precipitation occurs. When a precipitation event does occur, the amount is determined by generating from a skewed normal distribution. Inputs necessary to describe this distribution for each month are the mean, standard deviation and skew coefficient for daily precipitation.

In the plant environmental control component of EPIC, mechanisms are provided for applying irrigation water, fertilizer and pesticide. With regard to irrigation, one has the option of simulating dryland or irrigated conditions. If irrigation is indicated, one has to specify the runoff ratio (the volume of water leaving the field divided by the volume applied), a plant water stress factor to trigger the

irrigation and whether water is applied by sprinkler or by furrow irrigation.

The model is able to generate crop yield estimates for various combinations of soil qualities, crop management practices and irrigation strategies. A wide variety of crops can be accommodated. Two important results from this model are the annual crop yield figures over the planning horizon and the associated irrigation water demands.

### Economic Model

The economic model is based on standard linear programming (LP). LP requires that both the objective function and the constraints be in a linear form. In this research, the objective function is to maximize net revenue subject to a number of constraints which represent physical and/or organizational restrictions for a particular setting. One main advantage of this technique is that existing computer software packages can be used (Hazell and Norton, 1986).

The general form of LP is:

$$\text{Max } Z = C^T * X \text{ (or Min.)}$$

$$\text{Subject to : } AX \leq B$$

$$X \geq 0$$

where  $C^T$  = the transposed n-dimensional vector of objective function coefficients,  $X$  = n-dimensional vector of decision variables,  $B$  = m-dimensional vector of right-hand sides (resource constraints),  $A$  = m x n matrix of technical coefficients and  $Z$  = objective function value. The general form of the linear programming tableau is depicted in Table 1.



The linear program is solved by the simplex technique, an iterative procedure whereby a systematic "scanning" of a finite number of corner points in the convex

TABLE 1  
GENERAL FORM OF THE LINEAR PROGRAMMING TABLEAU

	COLUMNS				
ROW NAME	$X_1$	$X_2$	..	$X_N$	RHS
OBJ.FUNCTION	$C_1$	$C_2$	..	$C_N$	MAX
RESOURCE CONSTRAINTS					
1	$a_{11}$	$a_{12}$	..	$a_{1N}$	$\leq b_1$
2	$a_{21}$	$a_{22}$	..	$a_{2N}$	$\leq b_2$
.	.	.	..	.	$\leq .$
M	$a_{M1}$	$a_{M2}$	..	$a_{MN}$	$\leq b_M$

policy space finds a global optimum.

#### Dynamic Programming Model

Dynamic programming (DP) is an optimization technique which is especially appropriate for serial systems such as reservoirs. In principle, DP is capable of handling nonlinear, stochastic and even non-continuous problems. Computer algorithms are specifically developed for each application, rather than standardized as in LP.

Several DP terms need to be defined. A stage is defined as the portion of the problem that possesses a set of mutually exclusive alternatives from which the best alternative is to be selected. Every stage has a number of states. A state variable transfers information between the various stages. Furthermore, it allows one to make optimum decisions for the remaining stages without having to check the effect of future decisions on decisions previously made. Each stage produces an output (stage return,  $r$ ), which is a function of the inputs to the stage and the decisions made for that stage. The general form of a serial decision problem (Figure 3) shows the stages represented by numbered rectangles, with arrows used to indicate inputs and outputs to the various stages. All outputs which are not returns ( $r_i$ ) are called state variables ( $s_i$ ), where  $i$  is the index of the inputs generating the state. All inputs which are not states are called decision variables ( $d_i$ ).

The technique of DP solves the entire problem sequentially in stages, with each stage involving exactly one optimizing variable. Through recursive equations these computations at different stages are interlinked and finally yield a feasible optimal solution to the entire problem. The mathematical statement of Bellman's Principle of Optimality for serial multi-stage systems is (Bellman, 1957):

$$f_{n+1}(s_{n+1}) = \text{MAX} [R_{n+1}(d_{n+1}, s_{n+1}) + f_n(d_{n+1}, s_{n+1})]$$

$$n = 1, \dots, N-1$$

where:       $N$  = the number of stages

$f_i$  = the objective function value from stage 1 to stage  $i$

$s_i$  = state of stage  $i$

$r_i$  = return from stage  $i$

$d_i$  = decision at stage  $i$

$R_n$  = total return over all stages  $(1, \dots, n)$

This principle states that the optimal policy  $d_N^*(s_N), \dots, d_1^*(s_1)$  for an  $N$ -stage system must be such that the subset of decision functions  $d_n^*(s_n), \dots, d_1^*(s_1)$  ( $n=1, \dots, N$ ) is optimal for the last  $n$  stages of the  $N$ -stage system, for any input  $s_n$ .

Each additional state variable results in an increase in the number of evaluations for the various alternatives at each stage. An increase in state variables may cause computer memory requirements to be excessive. Bellman calls this "The Curse of Dimensionality". The technique of DP can be applied in two ways--either forward recursion or backward recursion. Forward recursion refers to a solution procedure which runs forward in time. Backward recursion runs in the opposite direction. There is no difference in the two approaches with regard to the end result. In many cases the selection is made based on computational considerations or constraints.

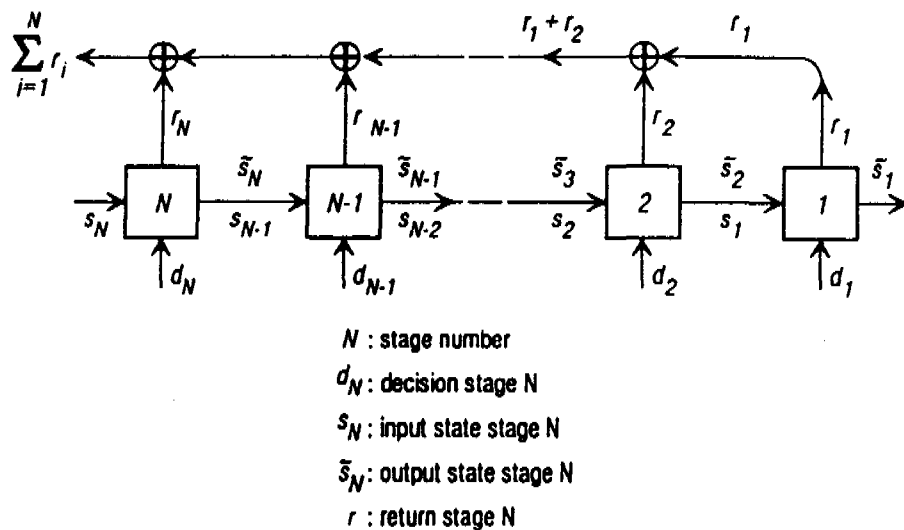

Figure 3. General Form of a Serial Decision Problem

## CHAPTER IV

### SOLUTION PROCEDURE AND MODEL LINKAGES

#### Overview of the Physical Setting

The physical system under consideration contains four primary components: the catchment area, the irrigation reservoir, the canal infrastructure and the irrigated land (Figure 4). The most upstream component in this setting is the catchment area which transforms rainfall into runoff. The second component is the reservoir itself which acts as a recipient for the runoff coming from the upstream catchment area and the precipitation which falls directly in the reservoir. Furthermore evaporation from the lake's surface area and seepage/leakage from the reservoir take place, as well as release of irrigation water from the reservoir to the downstream irrigated land area. The third component is the irrigation canal infrastructure which conveys the released water from the reservoir to the respective locations within the irrigated land area. The fourth component consists of the potentially irrigable land which is divided into a number of different land units. Each land unit has its own soil characteristics. In principle these units can be considered as organizational units and are in the range from several hundred to several thousand hectares.

The DP combines the outputs from the hydrologic model, the crop growth simulation model and the economic model into a sequential decision process.

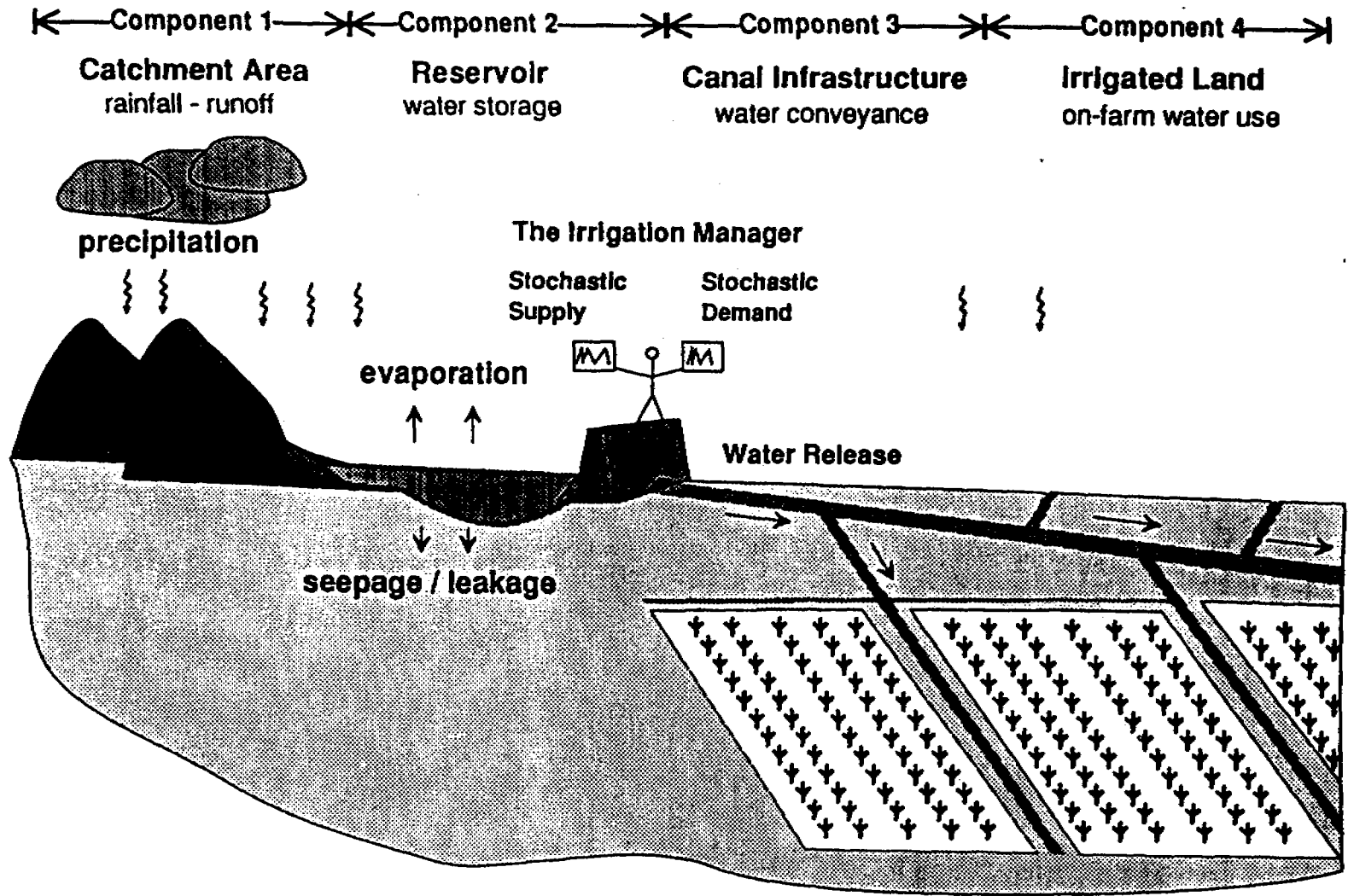

Figure 4. The Physical Setting of the System under Consideration

Furthermore, it incorporates historical lake evaporation data.

Every simulation run (Figure 5) performed covers a time period which equals the user-specified planning horizon. If the planning horizon is determined to be  $P$  years, then one single simulation run also covers  $P$  years. However, one needs to repeat this planning horizon of  $P$  years a number of times to make a probabilistic interpretation of the individual results obtained from each loop. In other words, the DP is solved repeatedly. Each solution incorporates a different generated weather pattern. Performing one particular realization of a complete planning horizon provides an optimum inter- and intra-seasonal land/crop/water allocation based upon the assumptions made.

The outputs from the individual models will be briefly discussed followed by a discussion of the model linkages illustrated with an example calculation.

#### Hydrologic Model

As discussed previously, the hydrologic model deterministically produces a daily runoff data series based upon a (generated) meteorological time series over the planning horizon.

#### Crop Growth Simulation Model

Time series of daily weather data are prepared using either historical information or EPIC's weather generator. EPIC provides seasonal yield estimates over that selected time series for the crops being considered. Yields are generated for each soil type represented in the irrigated area for a range of different irrigation strategies.

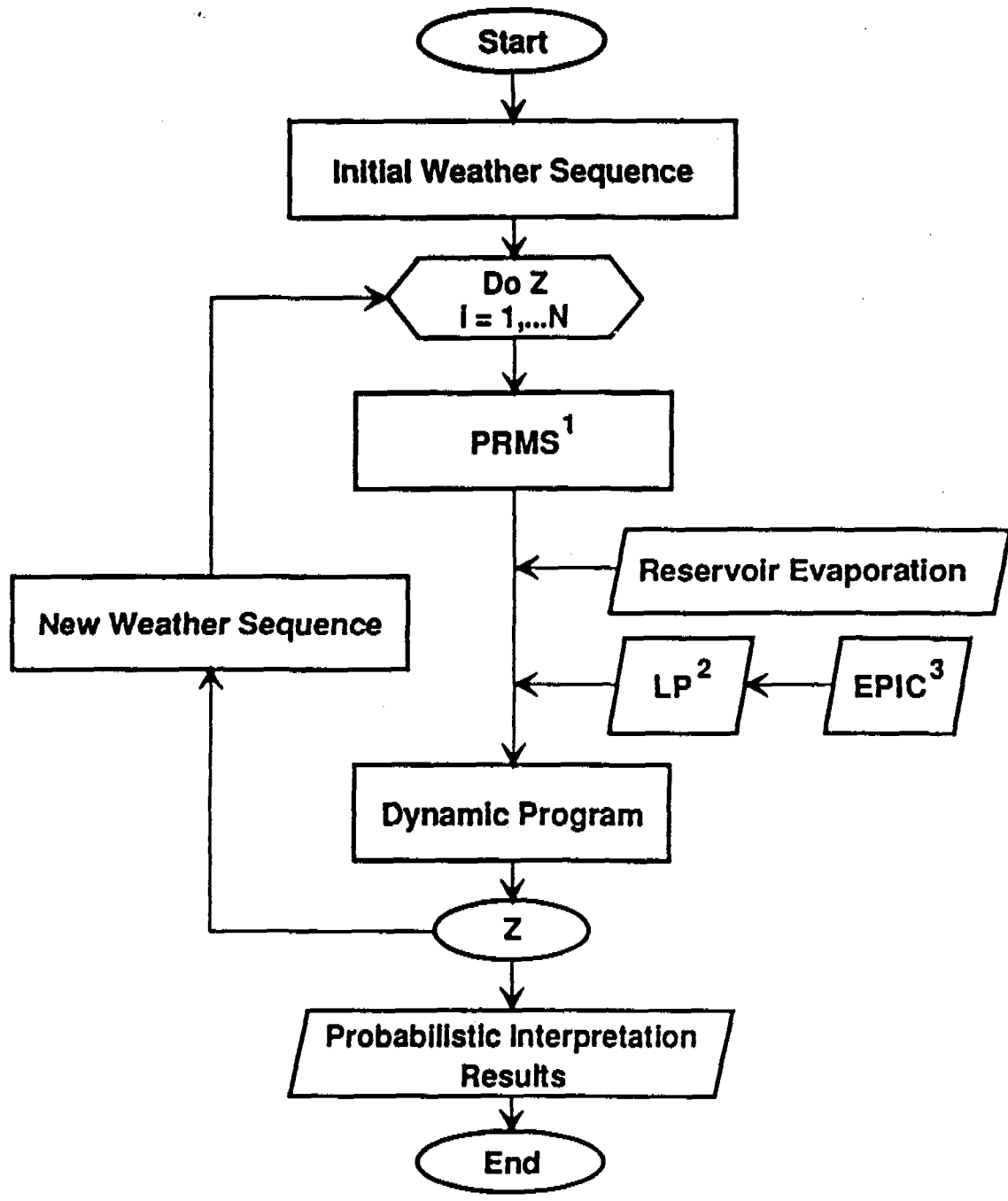

- 1 Precipitation Runoff Modeling System (hydrologic model)
- 2 Linear Program (economic model)
- 3 Erosion Productivity Impact Calculator (crop growth model)

Figure 5. General Flowchart of the Proposed Methodology

A concern with crop growth simulation models relates to initial conditions, especially regarding soil moisture status at the beginning of the season. To minimize this problem, EPIC is run in a continuous fashion over the entire length of the time series to incorporate carry-over moisture from one year to the next.

#### Economic Model

For each crop-soil-irrigation strategy combination, yield figures for the individual years are transformed into net revenues through a farm budget which includes fixed and variable costs for field operations. This set of net revenues is then inserted into the economic (LP) model. Furthermore, the economic model incorporates the physical characteristics of the irrigation canal network through assigned water conveyance efficiencies. These efficiencies are separately determined or assumed for each part of the canal network.

The LP model has been set up to produce the optimum farm plan (intra-seasonal) which consumes a certain quantity of irrigation water. A farm plan consists of an allocation of crops, assigned to certain physical locations within the irrigated area and associated with certain irrigation strategies.

#### Dynamic Programming Model

A DP model is used whereby the stages are represented by years (divided into a crop growing season and an off-season), the states are the discretized reservoir levels and the decisions are the various possible farm plans (land/crop/water allocations). The DP links all the years together, incorporates optimum intra-seasonal



farm plans determined by the economic model and assigns an optimal path through those years. The objective is to maximize the net revenue over the planning horizon. A backwards DP solution procedure is used because the resulting optimal path can be traced through the various stages in a forward fashion, which is convenient for the interpretation of the results.

#### Linkages between Model Components

To facilitate the "looping" process depicted in Figure 5, EPIC's weather generator is used to develop multiple sequences of weather data covering the desired planning horizon. These generated weather sequences are fed into PRMS which then deterministically calculates the runoff associated with each particular weather sequence.

The runoff data (generated in a daily mode by PRMS and aggregated seasonally), long-term (historical) lake evaporation data and the optimum intra-seasonal farm plans (identified by the economic model) are fed into the DP program. Each simulation produces the optimal path of selected farm plans through the planning horizon together with associated revenues. This process is repeated to incorporate the stochasticity of weather sequences. For every simulation, a new weather sequence is being generated which covers the entire length of the planning horizon. Newly generated weather sequences can be directly incorporated in PRMS, but only one multi-year realization of the weather distribution is reflected in the EPIC and LP results. In other words, new realizations of the weather pattern for the planning horizon lead to new outputs from PRMS, but the outputs for EPIC and for the LP

remain the same.

The primary reason for this approach is that the LP (which incorporates results from EPIC) is not sensitive to the particular sequence of occurrence. It does not discriminate between two data sets which have the same individual seasonal revenues but which show a different sequence in that time series. Basically the EPIC-LP combination provides a mean, expected revenue for each farm plan.

The planning horizon is divided into years which are in turn divided into a "season" and an off-season. A season coincides with the crop growing activities. The off-season is used in the model to allow the reservoir to fill up for the next growing season. Crops selected are restricted to annual crops only. Perennial crops would require an adjustment in the solution procedure.

Fortunately in this research, the number of state variables can be reduced to a minimum thus avoiding the "Curse of Dimensionality" which was mentioned earlier. Only one state variable is needed and that is the reservoir level at the beginning of the growing season. All the other pertinent variables are already incorporated in the analysis, either directly or indirectly. In the hydrologic model, physical and hydrologic characteristics of the catchment area above the reservoir are included. The crop growth and economic models express the variability of land/crop/water allocation in time and space.

The reservoir level has been chosen as a criterion because that is the most accessible yardstick the single decision maker has at the time the land/crop/water allocation needs to be made. Using backwards computation, starting from a certain point in the future, one has to consider all possible reservoir levels at the beginning of

each growing season.

### Example Results

Figure 6 provides an example for two stages from a DP program. The actual numbers used are arbitrarily chosen and do not necessarily represent physical relevance. For stage 1 (1994), one considers each of three discretized reservoir levels (80, 60 and 40). These states are the possible reservoir levels at the beginning of the (growing) season. Each one actually represents a range of levels (e.g., 80 is the discrete value representing the range between 70 and 90). The second column for that stage indicates the various (intra-seasonal) farm plan alternatives as identified by the economic model. Each alternative has an expected revenue (column 3) and an expected water demand (column 4) associated with it. Because of deficit irrigation practices, the water demand shows a low coefficient of variation over the planning horizon and thus the water demand associated with a particular farm plan can be identified by a single value. In column 5 are the units of water which are added or subtracted due to direct rainfall into the reservoir, evaporation from the water surface, and seepage and leakage. These numbers represent the total of the season and off-season amounts. Column 6 represents the end of the off-season reservoir level.

The first row indicates that if one starts with 80 as an initial reservoir level (column 1) and chooses alternative 1 (column 2), the expected net revenue would be 160 (column 3). The water demand associated with that decision would be 20 (column 4) thereby reducing the reservoir level from 80 to 60. However, there has been an inflow of runoff water into the reservoir, precipitation that fell directly into

the reservoir and evaporation from the reservoir, both during the season and off-season; furthermore seepage and leakage should be considered. Incorporating the sum of these factors into the water balance results in an end of the off-season reservoir level of 75 (column 6).

The rest of the alternatives for this particular reservoir level and all alternatives for the remaining reservoir levels are calculated in a similar fashion. For all alternatives within one particular stage (year), the same generated precipitation and runoff are being used. The water demand varies across the alternatives; this is due to the different cropping patterns and irrigation strategies attached to those alternatives. In this example it has been assumed that farm plans can be implemented with a corresponding water demand which is no more than 50% of the starting reservoir level.

If optimizing over a single year, the reservoir would be depleted at the end of that year because there is no "incentive" to save water for the following year. To consider the carry-over effect from one year to the next, an optimization needs to be performed over a longer planning horizon. The interlinking between two sequential years is achieved through the reservoir levels. The reservoir level at the end of the first year (1993) must coincide with the level at the beginning of the second year (1994).

Stage 2 in the DP solution reflects the year 1993. If one starts with a reservoir level (state) of 80 and takes the first alternative, the end-of-the-season reservoir level is 81 (column 6). This number 81 links with the first reservoir level (80) of the first stage (1994).

If one starts from the first reservoir level (80) and picks alternative 1, the total revenue for the two stages is 370 (160 plus 210). All alternatives for this particular reservoir level and other reservoir levels are systematically calculated and then an optimum decision is made for a two-stage problem. The highlighted alternatives are the optimum alternatives for a 2-year planning horizon and a particular initial reservoir level.

One can appreciate the importance of including a second stage in this problem to provide an incentive for carry-over storage. One calculates backwards in time, but the optimal path is traced forward in time through the planning horizon.

1993  
Stage 2

1994  
Stage 1

DP - Solution Sequence

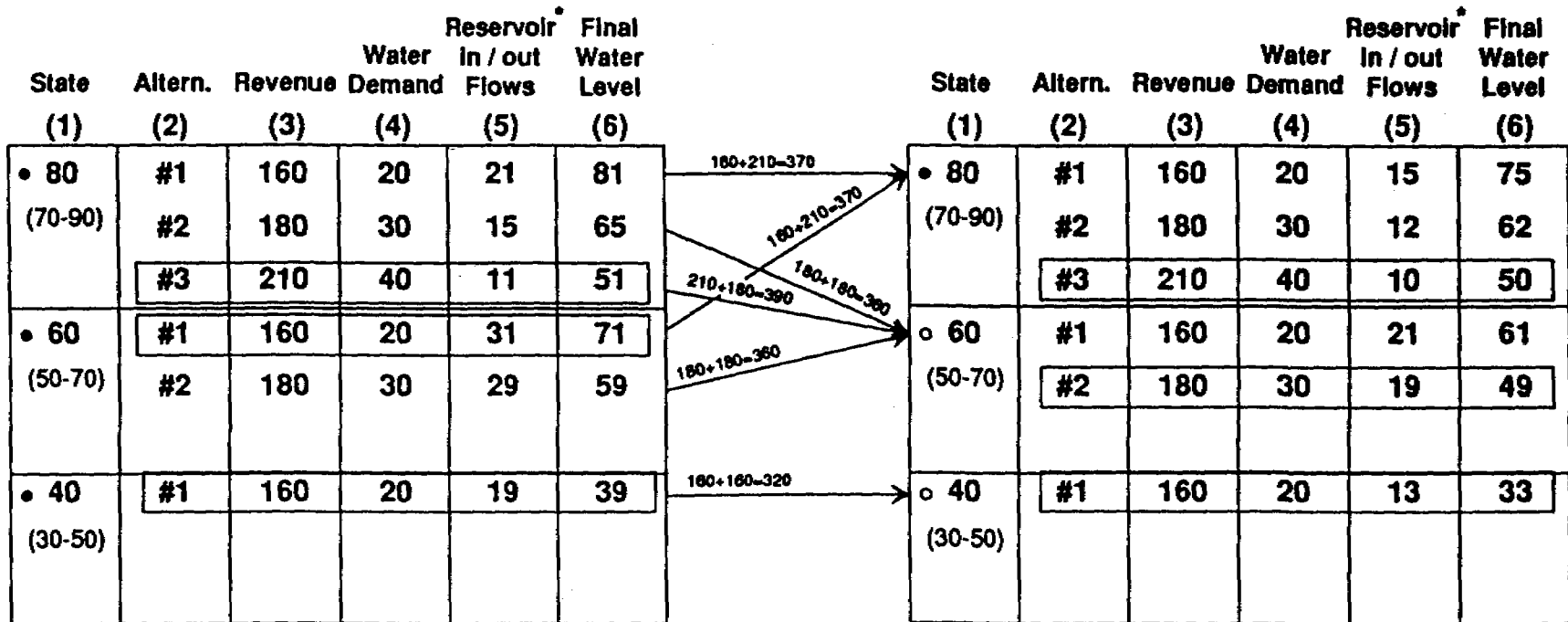

\* Except Irrigation Water Demand  
Time

Figure 6. Example Calculation of Two Stages in a DP Program

## CHAPTER V

### CASE STUDY RESULTS

#### Introduction

In this research, the modeling methodology is applied to a case study. Most of the physical characteristics and parameters associated with the case study are "real", but certain adjustments have been made to create a scenario which is realistic yet managable.

The case-study area is located in southwestern Oklahoma, USA and includes a single purpose reservoir (irrigation) linked to 18,000 ha of surface irrigated land via a canal system. The irrigated land area is called the Lugert-Altus Irrigation District. Water from the North Fork of the Red River is the source of inflows to the reservoir (Figure 7). The reservoir's catchment area is approximately 5200 km<sup>2</sup> and the capacity of the reservoir is about 120 million m<sup>3</sup>. The climate can be described as subhumid with a mean annual precipitation of approximately 500 mm; hot, dry summers are prevalent. The elevation of the catchment area ranges from 800 to 1000 m, while the elevation of the irrigated area varies between 350 and 500 m. The region's irrigated soils are predominantly clay loam, but other soil types are included here to bring more diversity into the model. Four different soil units have been assigned to the project setting, varying in texture from sand to clay loam.

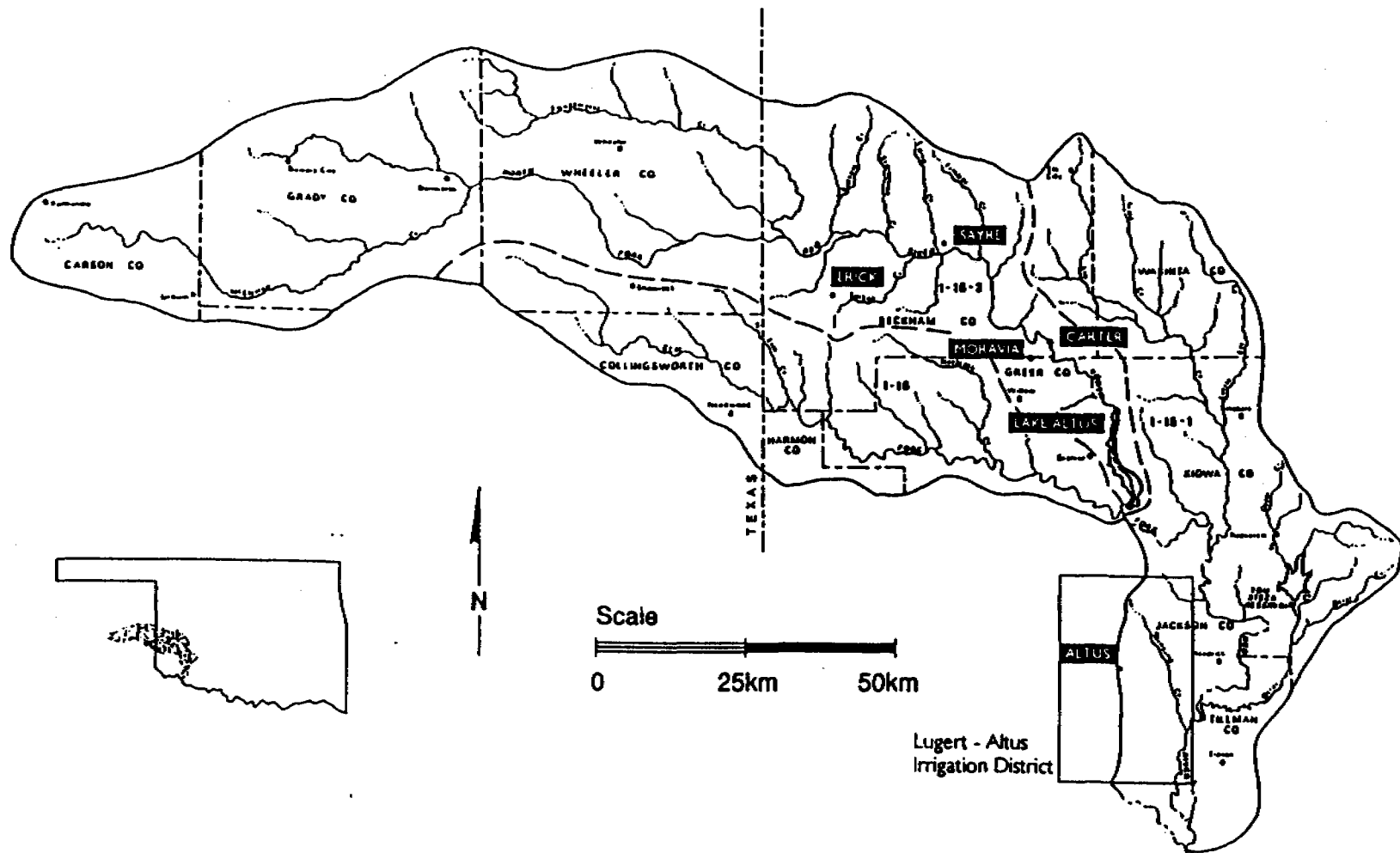

Figure 7. Location of Case Study Area and its Stations



Two annual crops (cotton and grain sorghum) are considered in the case study, although winter wheat and alfalfa are also grown in the area. Intermittent irrigations are to be made during the crop growing season between May 1 and November 1 for a limited number of times (3-5). The Soil Conservation Service (1988) states in a watershed plan for that area that:

".. the availability of water is the predominant restriction to agricultural production."

and;

"An analysis of 34 years of water records indicates a shortage occurred 85% of those years (29 of 34 years)."

However, the term shortage is not specifically described in that document. In spite of the presence of the irrigation reservoir with over-year capacity, it is difficult to quantify the decision making regarding crop/water/land allocations for a particular season.

A variety of hydro-meteorological data were gathered for the case study area. Moravia was chosen as the representative weather station for the catchment area under study (Figure 7). It is near the stream gage site, and its climatology is very similar to that of other stations in the area. Thirty-six years of daily precipitation and temperature data were obtained for the Moravia station (personal communication, Oklahoma Climatological Survey, 1991).

For measurements of flow in the North Fork river, a stream gage near Carter met the following two conditions: 1) a location as close as possible to the upstream end of the Lugert-Altus reservoir (Figure 7); and 2) sufficiently long historical records (32 years of daily flow data were obtained for the Carter gage) (personal

communication, U. S. Geological Survey, 1992). The Moravia and Carter station data were used to validate the hydrologic model.

Lake evaporation data are an important part of the complete hydrologic picture. Personal communication with Mr. Ray Riley of the USDA Soil Conservation Service, Stillwater, Oklahoma, and other information (USGS, 1954; USGS, 1956) have indicated that the evaporation from the reservoir does not vary greatly from year to year. Therefore, considering that a seasonal aggregation of lake evaporation is used in the modeling, it is sufficiently accurate to use long-term seasonal average lake evaporation data. An evaporation atlas has been compiled for similar studies for the contiguous 48 states (National Oceanic and Atmospheric Administration, 1982).

Leakage (or seepage) of water through the dam and any spillage should be measured if possible. A stream gage downstream of the dam provided this information on a daily basis for 38 years (personal communication, U. S. Geological Survey, 1992).

Measurements have been made of on-farm water deliveries from the reservoir. These data were obtained for the period 1952-1986 (personal communication, Soil Conservation Service, 1991).

#### Hydrologic Model

The hydrologic model should give reasonable estimates of runoff expected for a particular weather sequence. The historical hydrologic and meteorologic data from Moravia and Carter were used to validate the PRMS model. PRMS provides a mean daily flow which can subsequently be aggregated to seasonal and off-seasonal

volumetric totals. With every run, EPIC produces a new weather sequence which covers the entire planning horizon and produces a new runoff sequence. Figure 8 compares observed and simulated run-off results (PRMS) for a particular period (1957-1963). The runoff data were averaged over six-months periods. The general trends in the observed flow are clearly followed by the predicted runoff for that time period. The mean and standard deviation of the observed and predicted six-months aggregated runoff were within 10% of each other.

### Crop Growth Simulation Model

The EPIC model performs simulations for all possible combinations of soils, crops and irrigation strategies based upon a generated weather sequence. Generated weather data derived from historical records give an indication of what one can expect in a certain multi-year planning horizon. A 20-year planning horizon is often used for economic analysis (Boisvert and McCarl, 1990) and that is the length used in this case study. However, 20 years of crop growth simulation may not always be sufficient. Figure 9 shows the soil types assigned to the four soil units in the irrigation district. To both unit 1 and unit 4 similar soil qualities have been assigned; consequently the respective crop growth simulations are also similar. The main crop in the irrigation district is cotton; grain sorghum has also been included in the case study. The selected irrigation strategies range from zero irrigation (rainfed) to minimum irrigation intervals of 120, 90, 60 and 30 days (total of 5 irrigation strategies). The maximum amount per irrigation is 100 mm. Thus 40 simulations are performed for a single 20-year weather sequence (four soil units x two crops x five irrigation strategies).

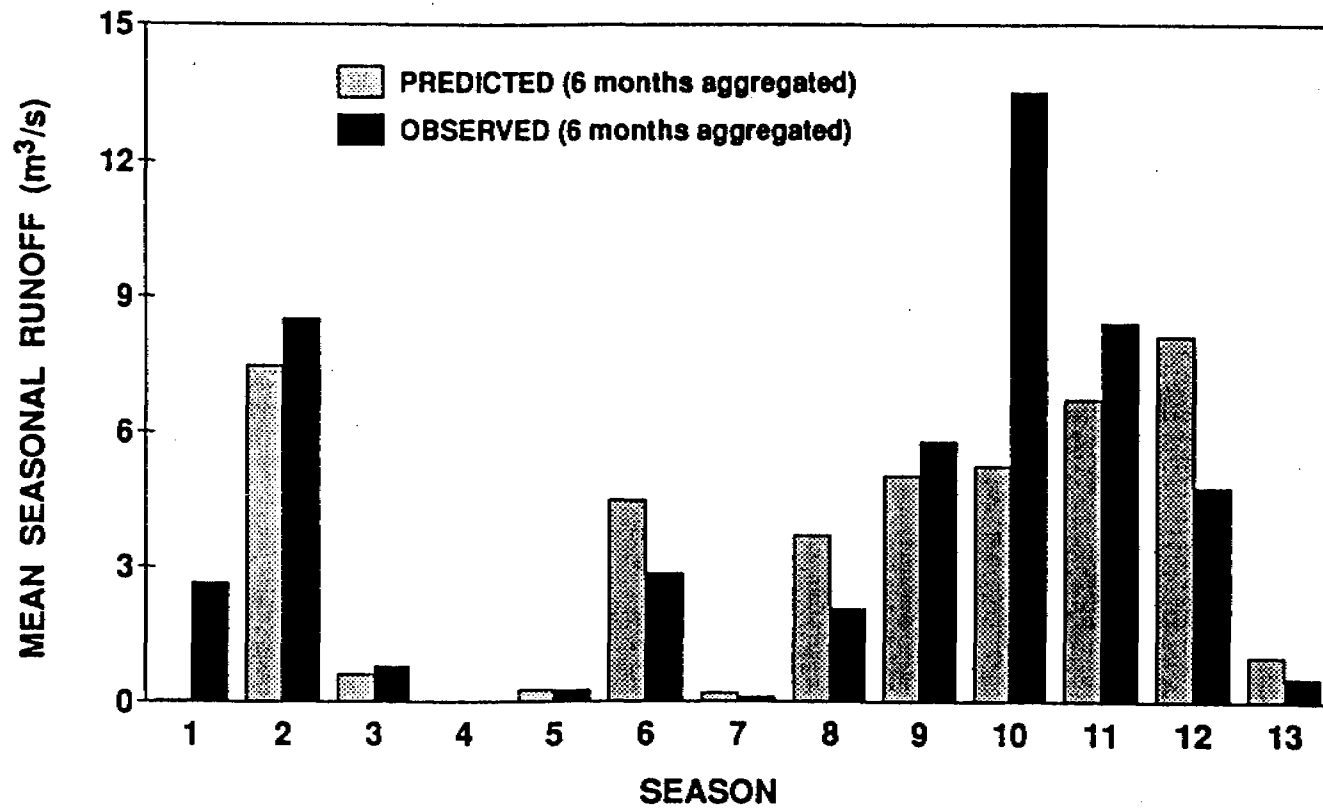

Figure 8. Observed and PRMS Predicted Runoff for a 6-Year Time Series (1957-1963)

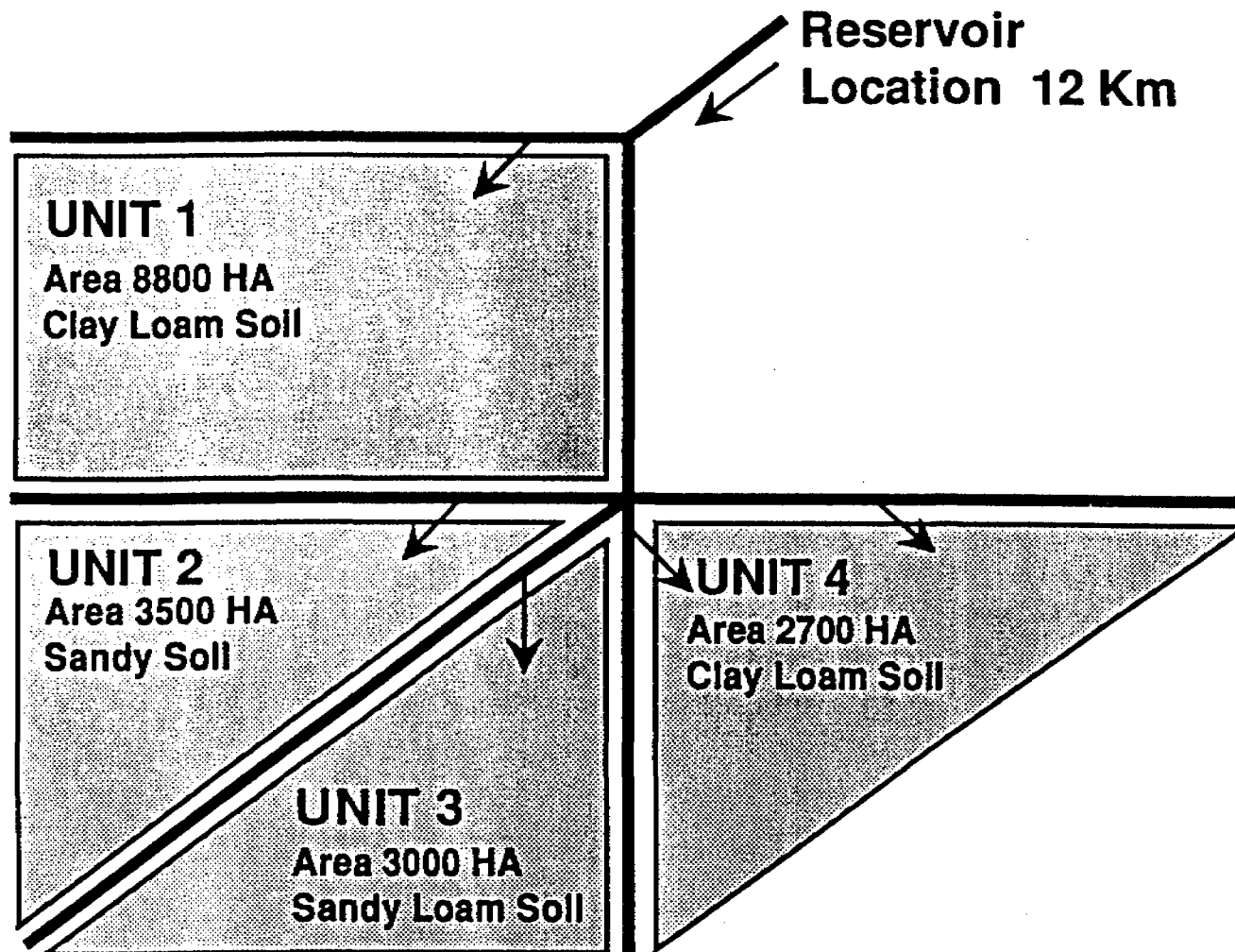

Figure 9. Location of Various Soil Units in Case Study Area

The generated annual rainfall over the 20 years is depicted in Figure 10. Total annual rainfall is not necessarily a good indicator of crop-effective rainfall. However, the higher the annual rainfall amount, the greater the chance that it contributes to meeting plant water needs during the crop growing season. The generated rainfall sequence for this 20-year realization is a sufficiently accurate representation of the historical data. The mean and standard deviation of the generated annual precipitation are 470 mm and 120 mm, respectively, while the values for the historical data are 560 mm and 110 mm.

Figures 11a, 11b and 11c present the EPIC grain sorghum results for each soil type and irrigation strategy. There is considerable yield variation from year to year, especially for the more limited irrigation strategies.

The EPIC results for cotton are presented in Figures 12a, 12b and 12c. Year-to-year variation and a sensitivity to the irrigation strategy are evident.

Although the yield simulations are revealing, an economic analysis gives a more complete picture of the merits of the various combinations.

#### Economic Model

The conversion of simulated yields into net revenues is accomplished with a farm budget representing an average farm in the southwestern part of Oklahoma (Kletke, 1989). The farm budget considers fixed and variable costs associated with certain crop and farm activities. The net returns calculated through the farm budget exercise are then used in the economic model.

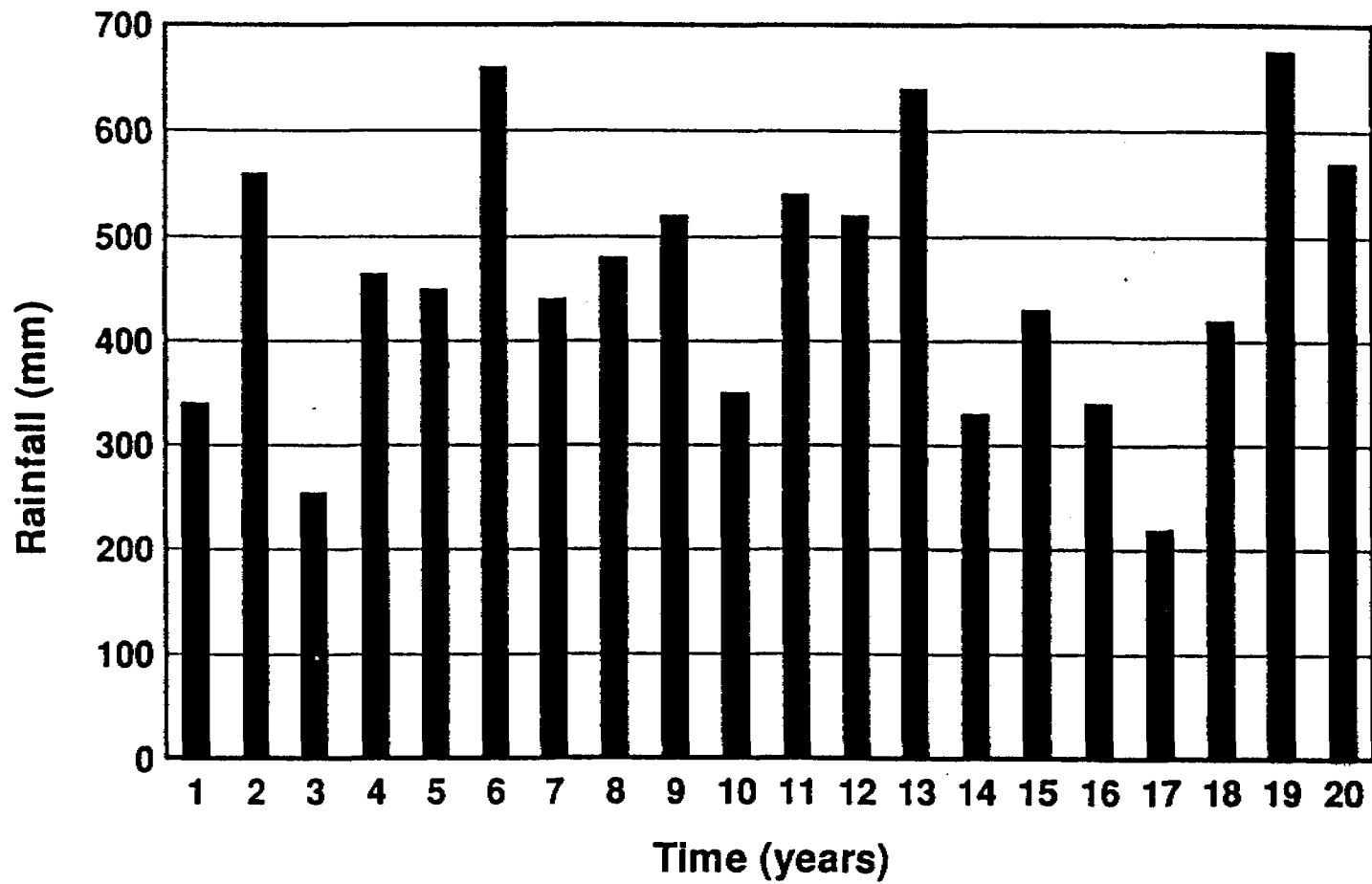

Figure 10. Annual Rainfall Pattern Generated by EPIC

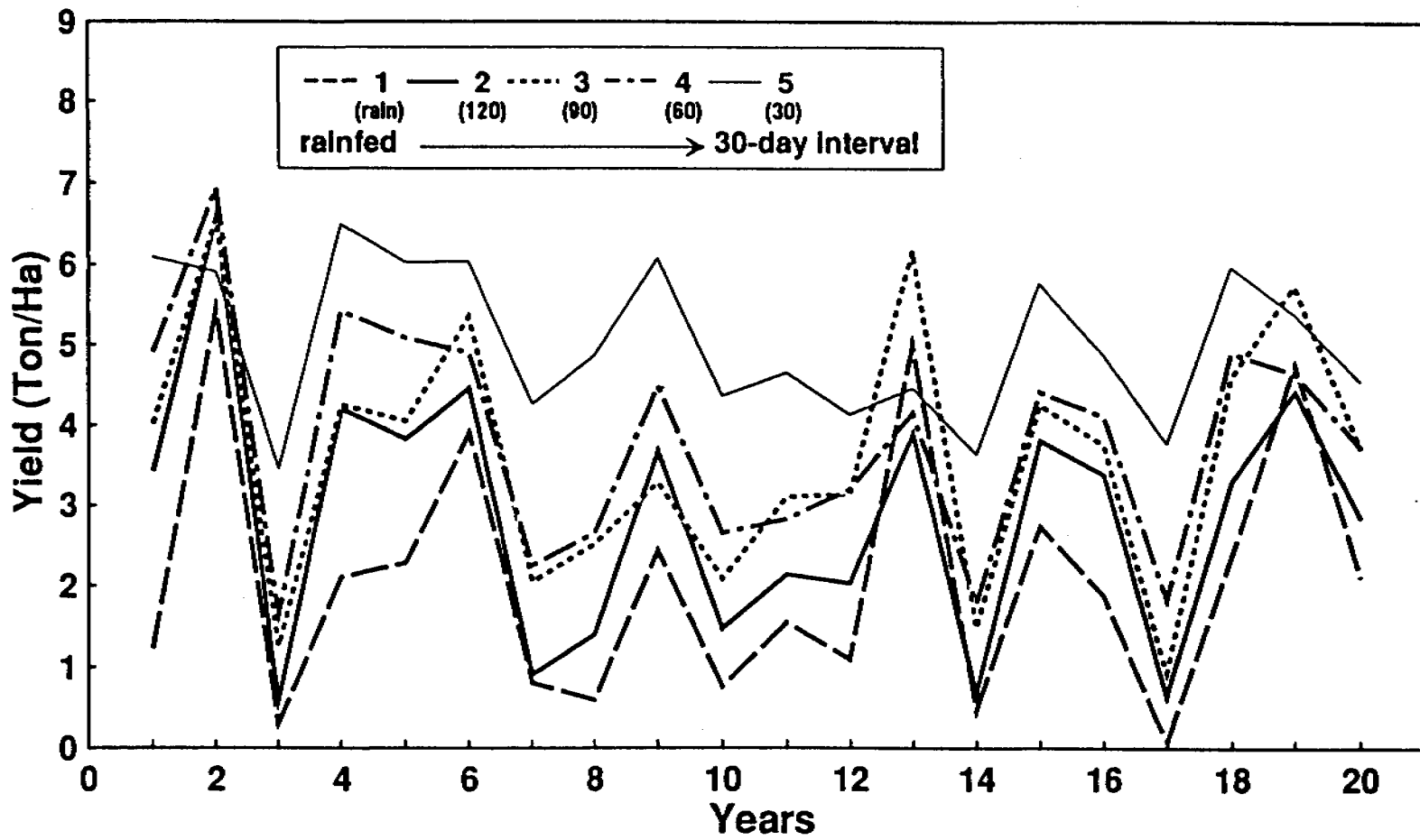

Figure 11a. Simulated Grain Sorghum Yields (Clay Loam Soils) for Various Irrigation Strategies



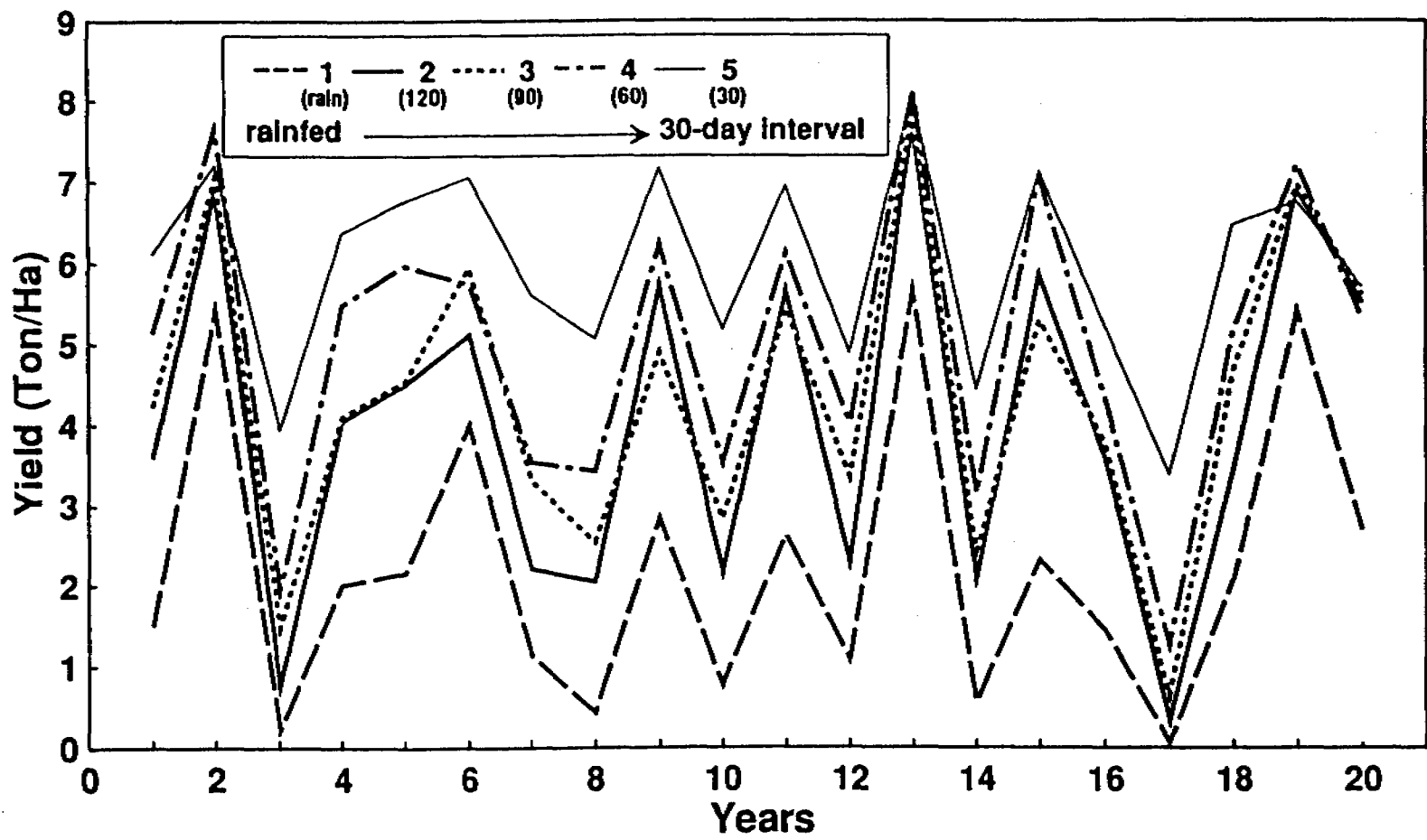

Figure 11b. Simulated Grain Sorghum Yields (Sandy Soils) for Various Irrigation Strategies

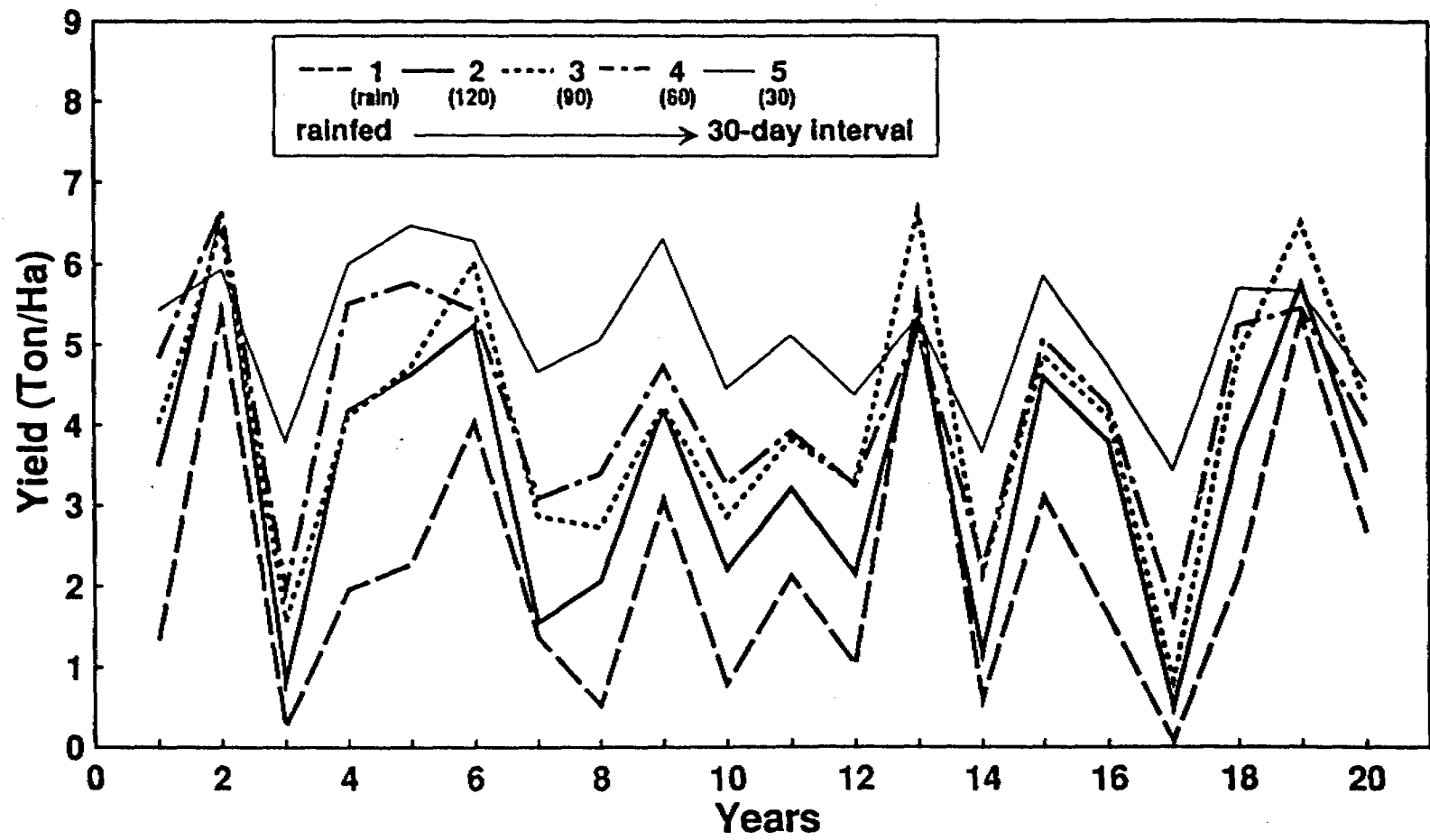

Figure 11c. Simulated Grain Sorghum Yields (Sandy Loam Soils) for Various Irrigation Strategies

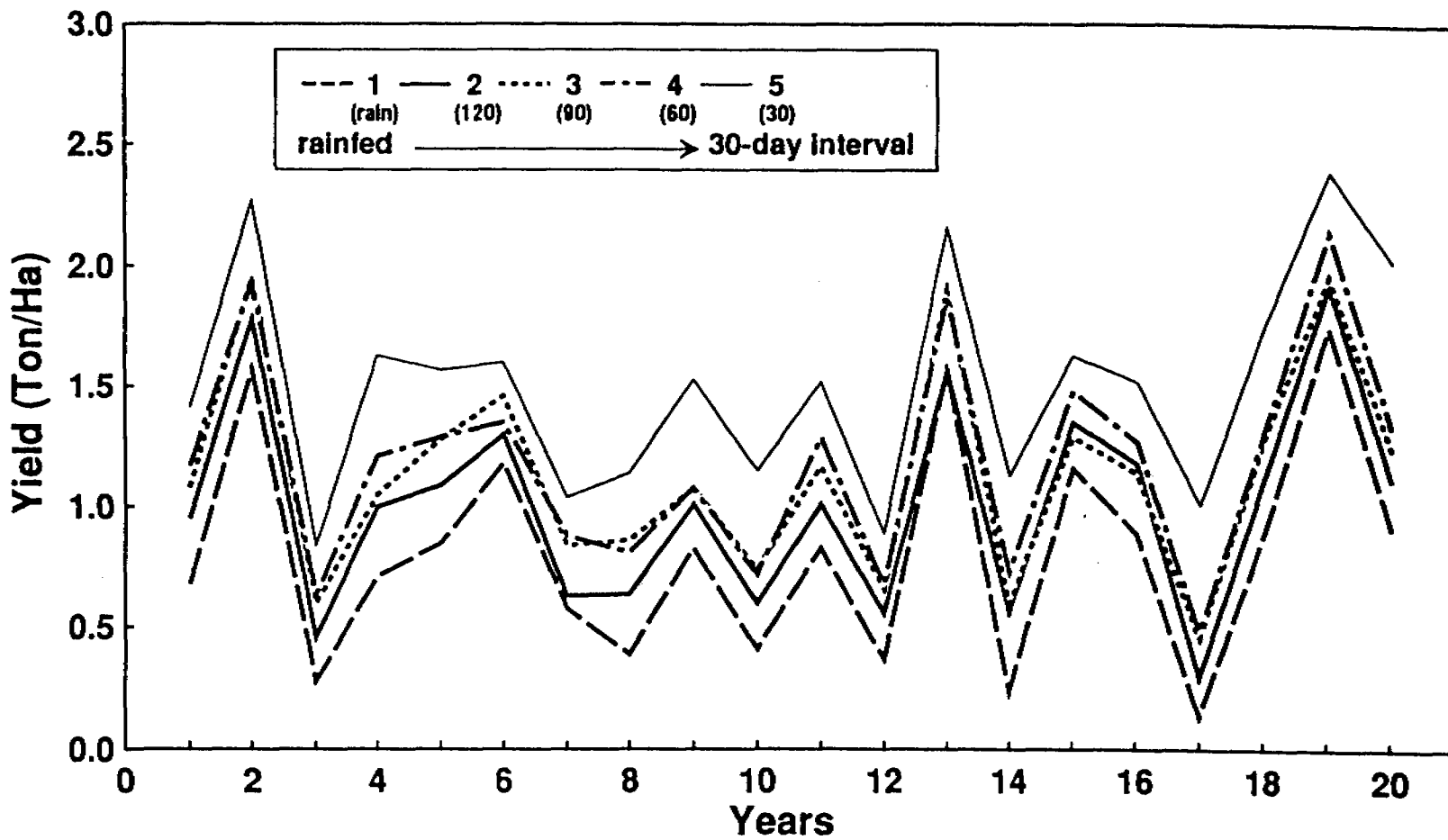

Figure 12a. Simulated Cotton Yields (Clay Loam Soils) for Various Irrigation Strategies

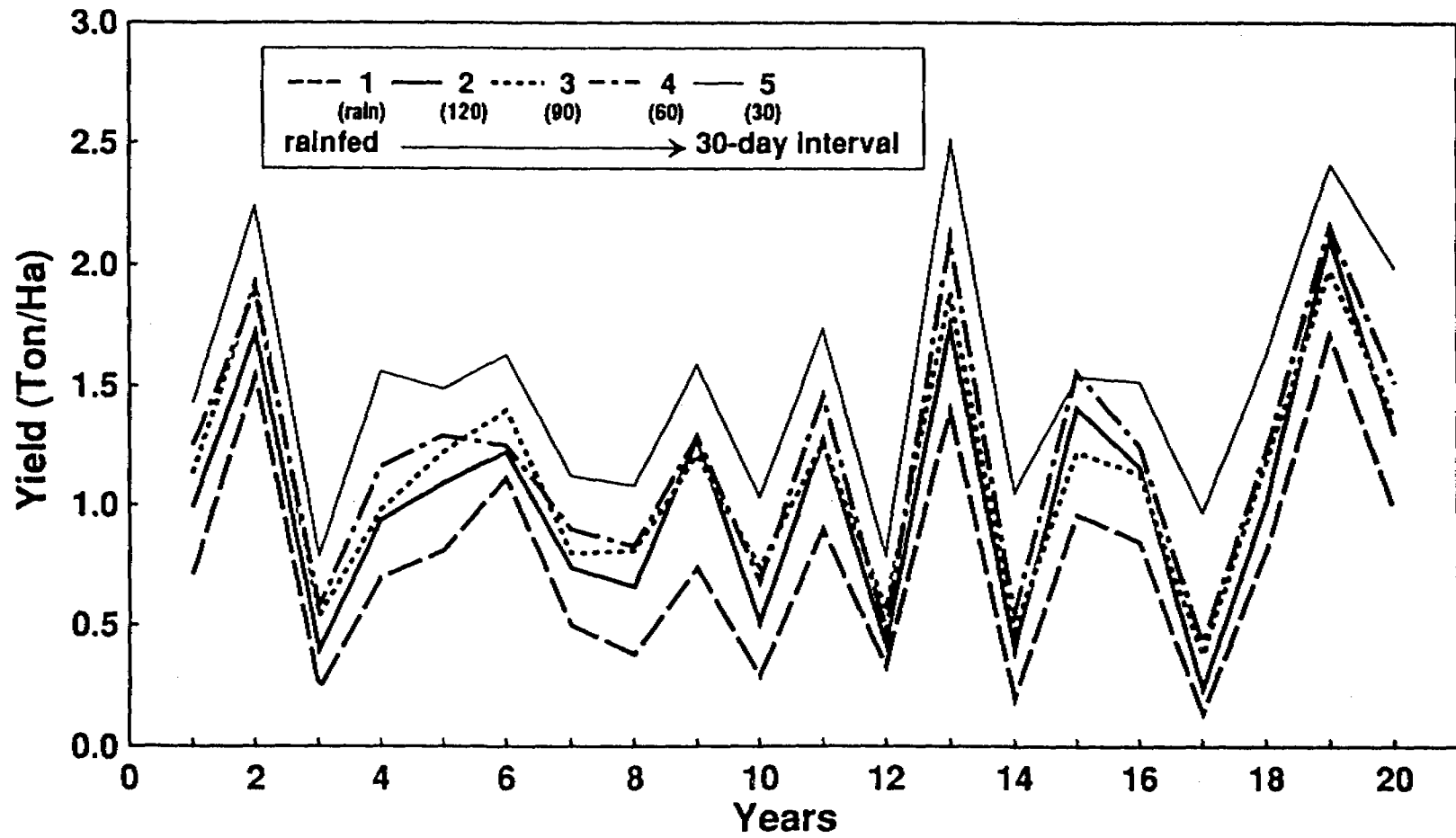

Figure 12b. Simulated Cotton Yields (Sandy Soils) for Various Irrigation Strategies

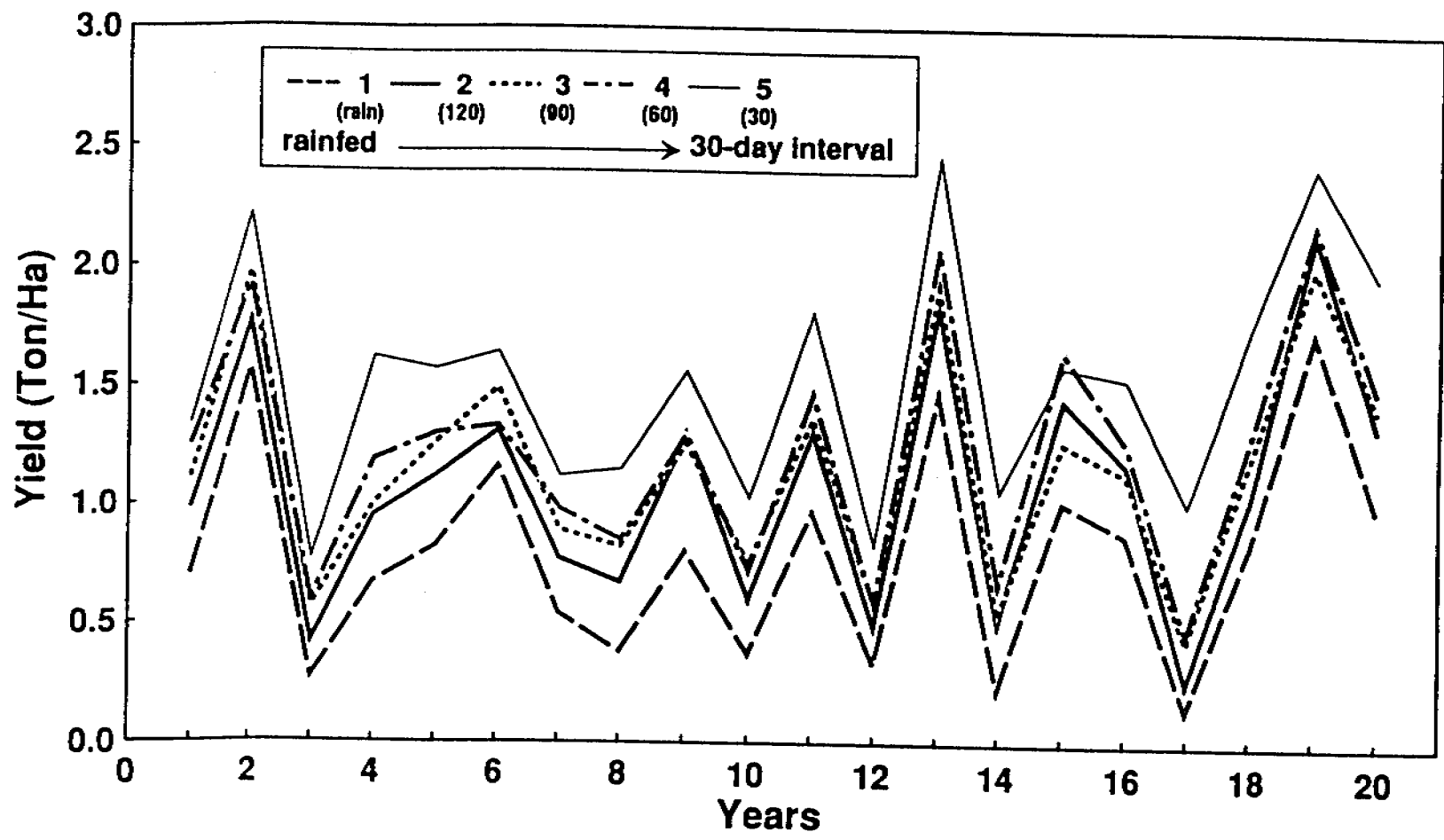

Figure 12c. Simulated Cotton Yields (Sandy Loam Soils) for Various Irrigation Strategies

In the economic (LP) model, three types of data have been incorporated:

1) the net revenues for the 20-year time period for the selected crops, soil units and irrigation strategies (20 values, each representing one season or year); 2) the water demand associated with each combination of crop, soil unit and irrigation strategy; and 3) the physical characteristics of the setting including water availability in the reservoir, conveyance efficiencies for main and secondary canal stretches, and sizes of land units.

There is only one economic model. However, the discretization of the total available reservoir capacity into a number of zones means that the economic model must be solved accordingly. In this case study, there are six reservoir zones (Figure 13). Each reservoir zone contains 20 million m<sup>3</sup>, which equals approximately 16% of the total reservoir capacity. The economic model needs to be solved seven times, once for each of the six zones and once for an "empty" reservoir condition. Each computer run represents a different water availability in the reservoir and consequently for the irrigated land area as well. The discretization of the reservoir capacity into six layers or zones is arbitrary.

Each farm plan is uniquely linked to a certain water demand (Figure 14). These irrigation water demands are incremental from farm plan 1 to farm plan 7 whereby farm plan 1 (no irrigation) reflects the lowest revenue. Farm plan 7 has the highest revenue but uses the most water and would deplete a full reservoir (zone 1). Farm plan 7 translates into planting 3 of the 4 land units with cotton, applied to the full acreage of each unit, and irrigated with the most frequent irrigation strategy. The other land unit would be planted with grain sorghum for this particular farm plan.

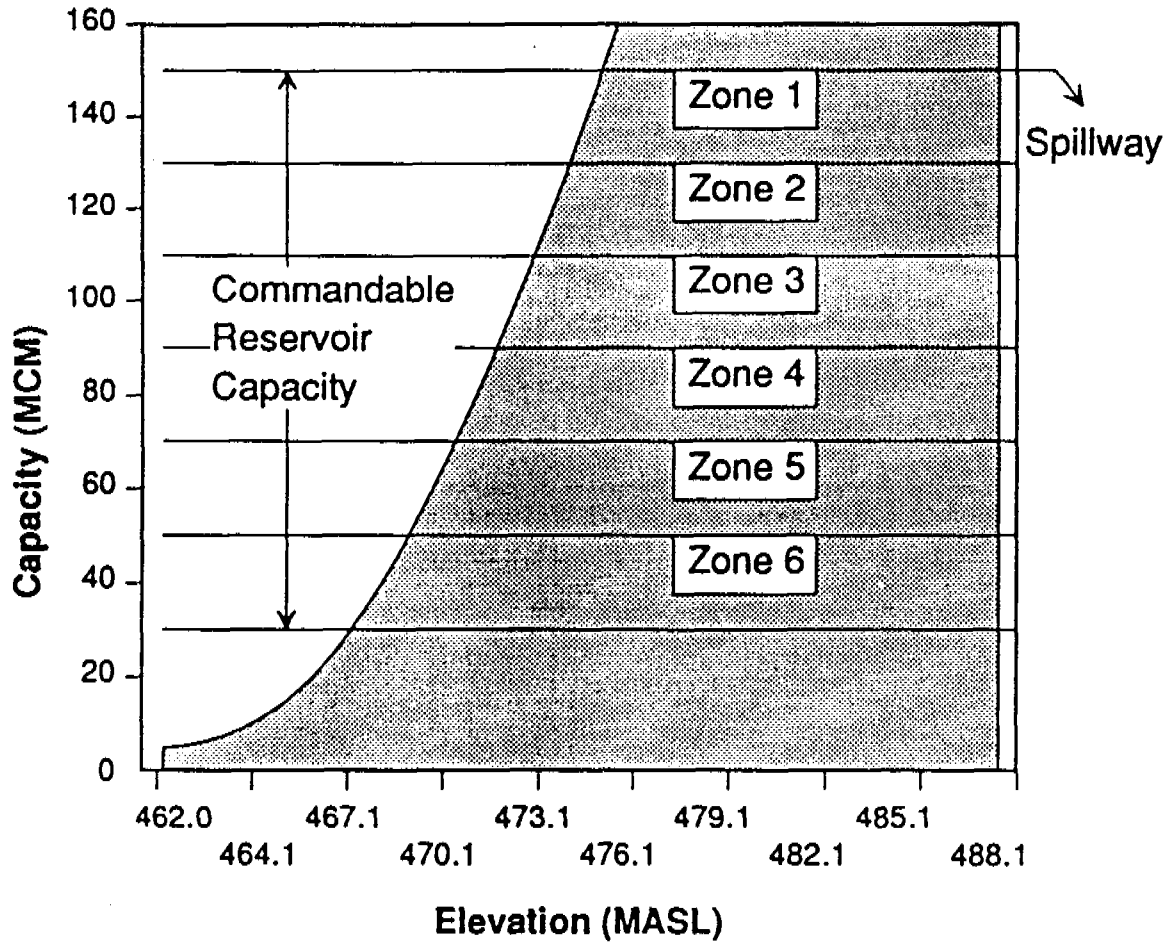
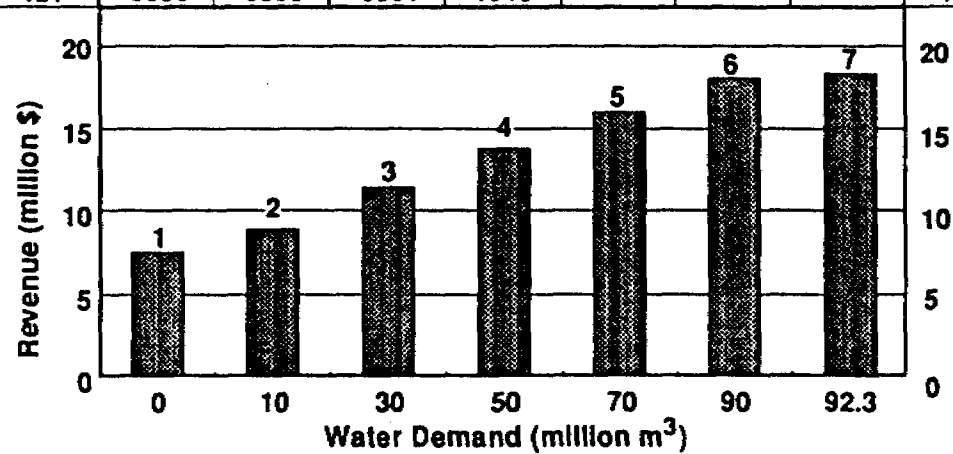

Figure 13. Altus Reservoir Elevation-Capacity Curve

FARMPLANS		1	2	3	4	5	6	7	FARMPLANS
2700	425 *						2311	2700	425 *
	421	2700 **	2700	2700	2700	2700	389		421
3000	325					1915	3000	3000	325
	321	3000	3000	3000	3000	1085			321
3500	221	3500	1353						221
	215		2147	3500	3500	3500	3500	3500	215
8800	125			2799	6885	8800	8800	8800	125
	121	8800	8800	6001	1915				121



\*  $\begin{matrix} 4 & 2 & 5 \\ | & | & | \\ \text{Unit} & \text{Crop} & \text{Irrigation strategy} \\ (1-4) & (1-2) & (1-5) \end{matrix}$     Crop 1: Grain Sorghum    Irrigation Strategy 1: rainfed  
 Crop 2: Cotton    2: 120-day irrigation interval  
 3: 90-day irrigation interval  
 4: 60-day irrigation interval  
 5: 30-day irrigation interval

\*\* Cropped Area (ha)

Figure 14. The Seven Alternative Intra-Seasonal Farm Plans



Farm plan 1 translates into planting all units completely, with cotton under rainfed conditions. Farm plans 2 through 6 involve various land/crop/irrigation combinations (Figure 15). Table 2 depicts the farm plans which are feasible to be implemented based on the amount of water available in the reservoir.

TABLE 2  
FEASIBLE FARM PLANS FOR EACH RESERVOIR ZONE

RESERVOIR ZONE	FARM PLAN ----->						
	1	2	3	4	5	6	7
1	X	X	X	X	X	X	X
2	X	X	X	X	X	X	NF
3	X	X	X	X	X	NF	NF
4	X	X	X	X	NF	NF	NF
5	X	X	X	NF	NF	NF	NF
6	X	X	NF	NF	NF	NF	NF

X : FEASIBLE FARM PLAN

NF: NON-FEASIBLE FARM PLAN

#### Dynamic Programming Model

The dynamic programming model performs its calculations according to the previously discussed diagram (Figure 5).

In Table 3, example results are shown for a single execution of the DP. The planning horizon is fixed at 4 years. For an initial reservoir level in zone 1,

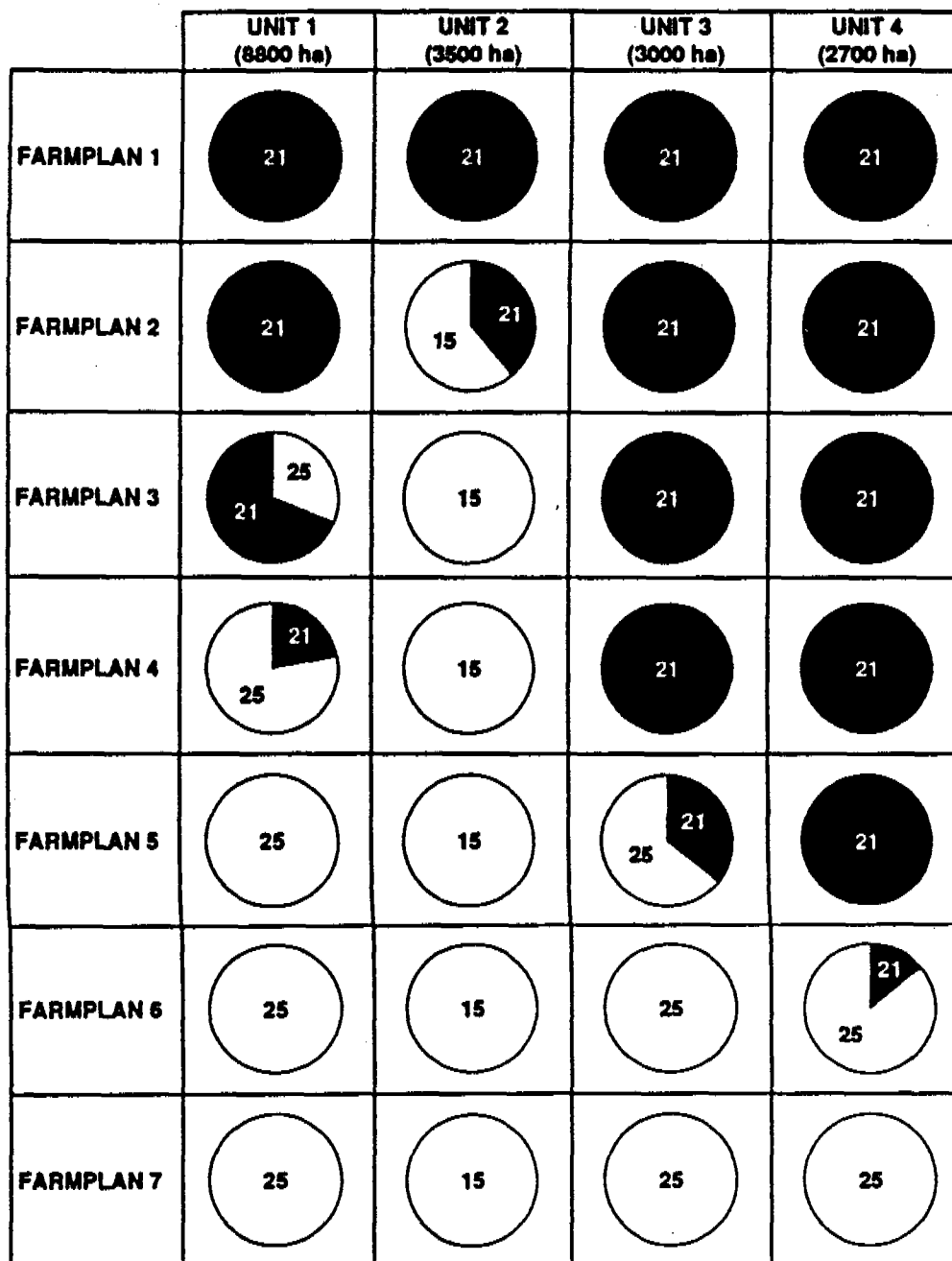

Crop  $\frac{2}{5}$  Irrigation strategy  
 Crop 1: Grain Sorghum  
 Crop 2: Cotton  
 1: rained ●  
 2: 120-day irrigation interval  
 3: 90-day irrigation interval  
 4: 60-day irrigation interval  
 5: 30-day irrigation interval ○

% Land unit assigned to a certain crop & irrigation strategy

Figure 15. Specification of Land/Crop/Water Allocation for each Identified Farm Plan

farm plan 7 would be selected as the best choice in year 1 assuming perfect knowledge of the weather over the ensuing 4 years. The following year, a new decision can be made. It is not necessary to make the crop/land/water allocation for a number of years in a row, since the beginning reservoir level is not known with certainty from year to year. The decision maker essentially always remains in the first year of the planning horizon.

From Table 3 it is clear that the farm plans selected in the last year of the planning horizon deplete the available reservoir water. At the end of the fourth year, there is no incentive for carry-over storage for following years. Therefore, for every reservoir zone in the last year of the planning horizon, the farmplan which depletes the respective reservoir zone will be selected. For zone 1, this corresponding farm plan will be plan 7, while for zone 6 this will be farm plan 2.

#### Analysis of Output

In this study, the total number of simulation "loops" (Figure 5) for each specified planning horizon was 80. This limit was imposed due to the array sizes of the results produced by the dynamic programming model. Once simulations have been performed, two distinctly different approaches are suggested for interpreting the DP results. In both approaches, the first year of the planning horizon is of primary interest since new cropping and water allocation decisions can be made annually.

The first approach assumes, for each run, a perfect knowledge of the weather throughout the planning horizon. The uncertainty of weather requires multiple runs to be made, with each run incorporating a different weather pattern over the planning

TABLE 3

**DP RESULTS REGARDING FARM PLANS SELECTED FOR  
4-YEAR PLANNING HORIZON (SINGLE SIMULATION)**

YEAR	1	2	3	4		
ZONE 1	7	5	4	7		
ZONE 2	6	4	4	6		
ZONE 3	5	1	1	5		
ZONE 4	4	1	1	4		
ZONE 5	1	1	1	3		
ZONE 6	1	1	1	2		

horizon. The DP results are then used to determine the probability of selecting a certain farm plan in year 1 of the planning horizon for a particular initial reservoir level. The effect of planning horizon length on probability levels can be evaluated by performing this analysis for different lengths.

The second and perhaps more realistic approach is based on the assumption that one does not know the weather in year 1 ahead of time. This analysis allows a non-optimum (in hindsight) decision in the first year. This can be modeled by fixing the farm plan in the first year (i.e., an initial condition), while the optimum path is found for the other stages in the planning horizon (perfect weather knowledge in subsequent years). The results can be presented as cumulative probability distributions of revenues which are accumulated over the entire planning horizon. Each distribution

is associated with a certain beginning reservoir level and a certain selected farm plan for the first year of the planning horizon. Again the influence of the length of the planning horizon can be investigated.

Approach 1. Optimizing over a 1-year planning horizon would simply cause all the available water in the reservoir to be consumed. This strategy does not provide for any carry-over reservoir storage at the end of year 1. In this trivial case, there is a 100% probability of selecting the farm plan which exhausts the reservoir and generates the highest revenue (Figure 16).

Any planning horizon longer than one year brings in the stochasticity of the reservoir inflows and thus diversification of the selected farm plans.

Figure 17 presents the results for a 3-year planning horizon. When starting with a full reservoir (zone 1), farm plans 4, 5 and 7 are almost equally likely to be chosen. Farm plans 1 and 2 are avoided because they have the lowest water demand and are not attractive when the reservoir is nearly full. Also, farm plan 6 is not selected in zone 1. The intra-seasonal LP results suggest that this anomaly appears to be due to the ratio of marginal revenue to marginal water demand associated with farm plan 7.

For reservoir zone 2, farm plans 1, 4 and 5 are the most likely chosen farm plans. Farm plan 6 enters in due to the non-feasibility of farm plan 7. The remaining zones (3-6) show farm plan 1 (rainfed) as the clear favorite.

If the initial water level is in reservoir zone 2 through 6, it is clear that farm plan 2 is inferior to the dryland option. Farm plan 2 includes an irrigation strategy of one irrigation every 120 days (essentially one irrigation per growing season). With

EPIC run in the "automatic" irrigation mode, this single irrigation event is likely to occur relatively early in the growing season. Apparently the beneficial effect of one irrigation is small relative to the cost associated with it.

Figure 18 presents results for a 5-year planning horizon. When starting with a full reservoir (zone 1), farm plan 4 is the most likely to be the optimum selection. When starting with a non-full reservoir (zones 2-6) over that same planning horizon, there is a clear shift toward farm plan 1, which is the dryland option. The previous comments regarding farm plans 2 and 6 also hold in this case.

Figure 19 shows the results for a 10-year planning horizon. For zone 1, farm plan 4 is clearly preferred and, along with farm plan 1, dominates in zone 2. Again, farm plan 6 is not selected if farm plan 7 is eligible. Farm plan 2 is selected in a few cases for zones 2 and 3, which is different from the results for the shorter horizons.

In Figure 20, the same type of analysis is presented for a 20-year planning horizon. Again farm plan 2 is largely neglected (zones 1-4) due to the particular nature of the LP results. Farm plan 1 is not one of the optimum scenarios for reservoir zone 1; its probability of selection increases progressively from zones 2 through 6.

This type of information could prove to be a useful tool for the decision maker. Based on the beginning reservoir level and the length of the planning horizon, a particular plot is identified. Then the decision maker can make a farm plan selection based upon the probability distribution of the various farm plans.

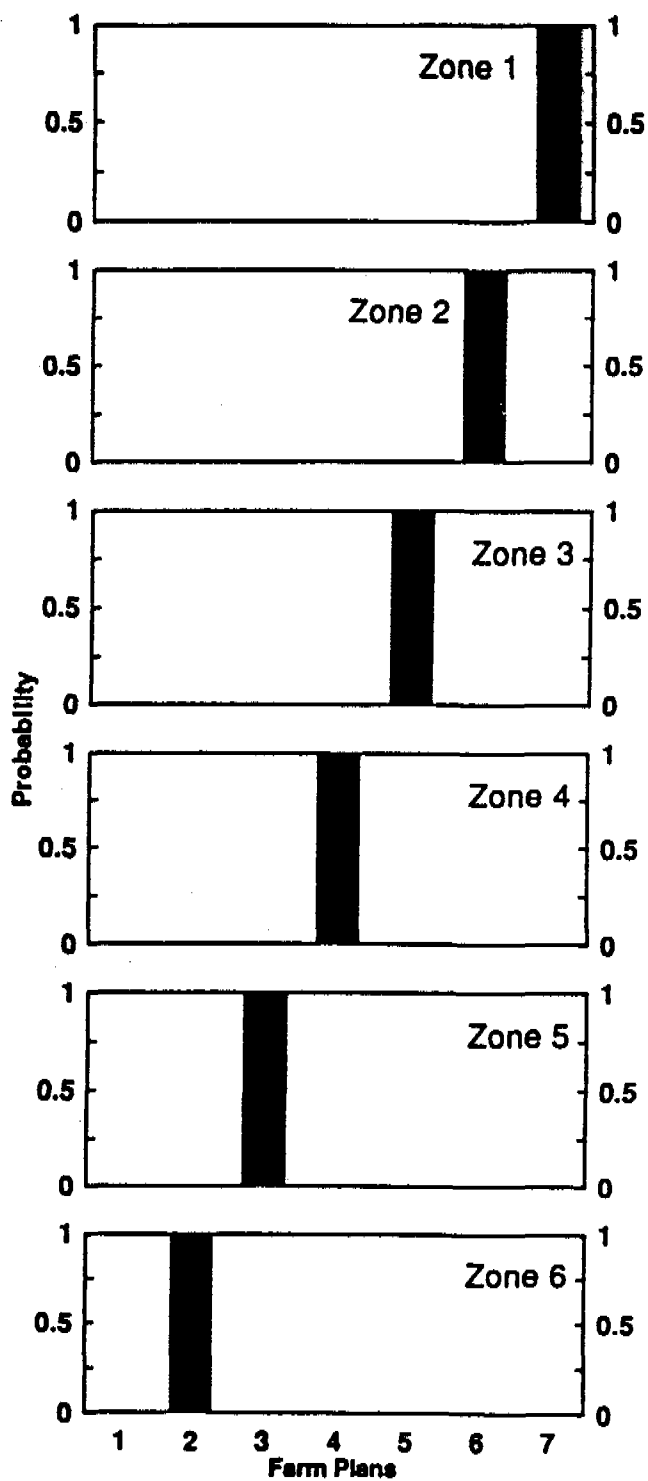

Figure 16. Probabilities that the Feasible Farm Plans will be Optimum in Year 1 of 1-Year Planning Horizon. Each Plot represents a different Initial Reservoir Level (Approach 1)

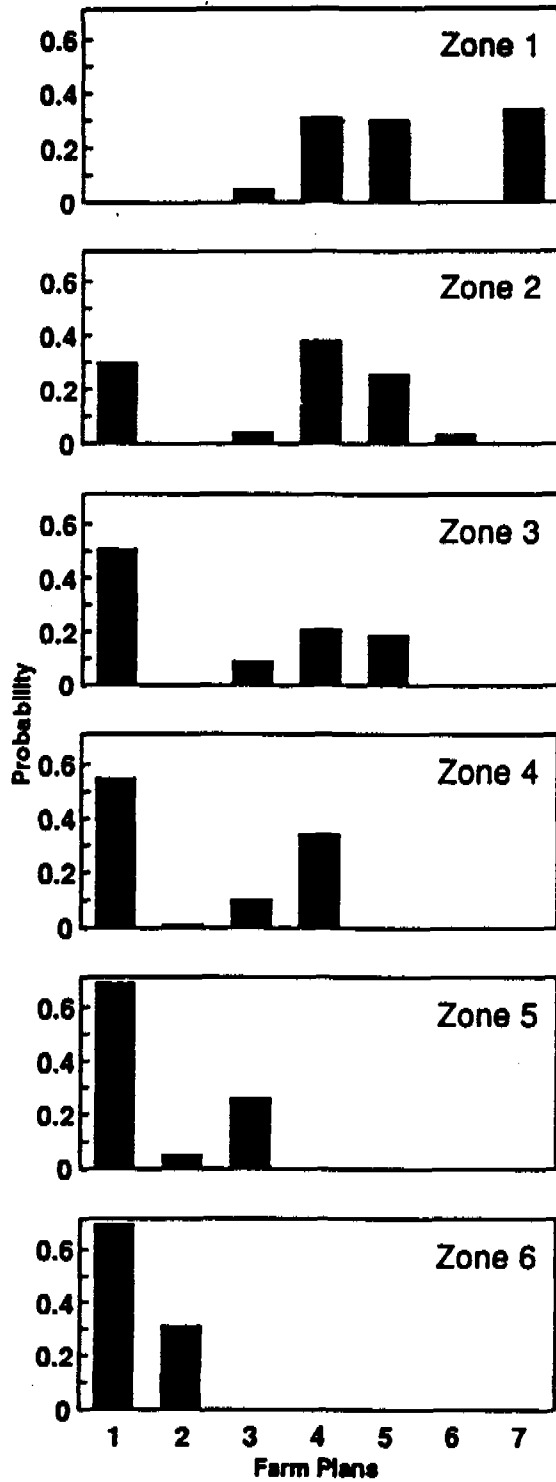

Figure 17. Probabilities that the Feasible Farm Plans will be Optimum in Year 1 of a 3-Year Planning Horizon: Each Plot represents a different Initial Reservoir Level (Approach 1)

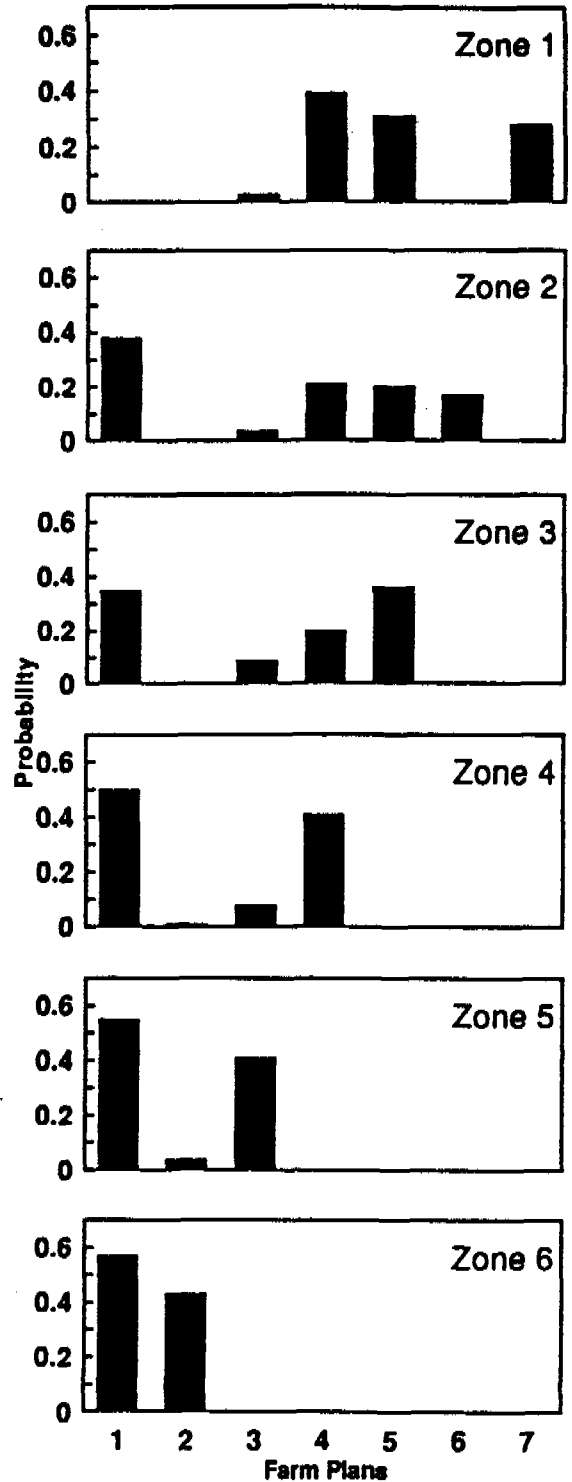

Figure 18. Probabilities that the Feasible Farm Plans will be Optimum in Year 1 of a 5-Year Planning Horizon: Each Plot represents a different Initial Reservoir Level (Approach 1)



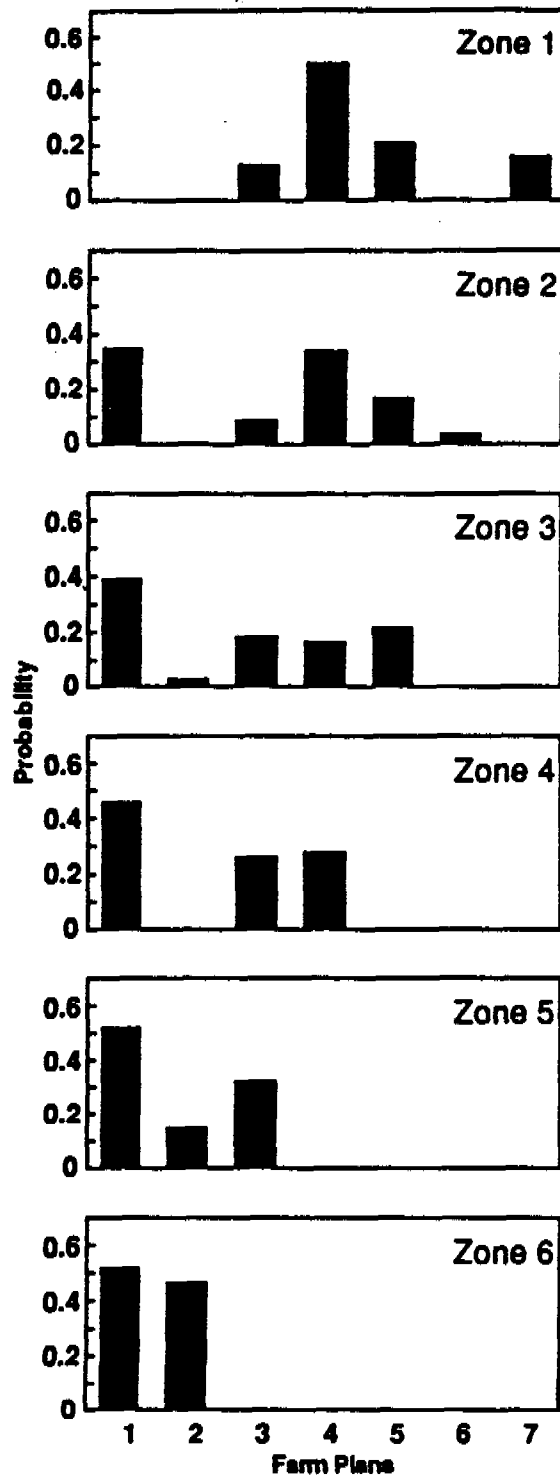

Figure 19. Probabilities that the Feasible Farm Plans will be Optimum in Year 1 of a 10-Year Planning Horizon. Each Plot represents a different Initial Reservoir Level (Approach 1)

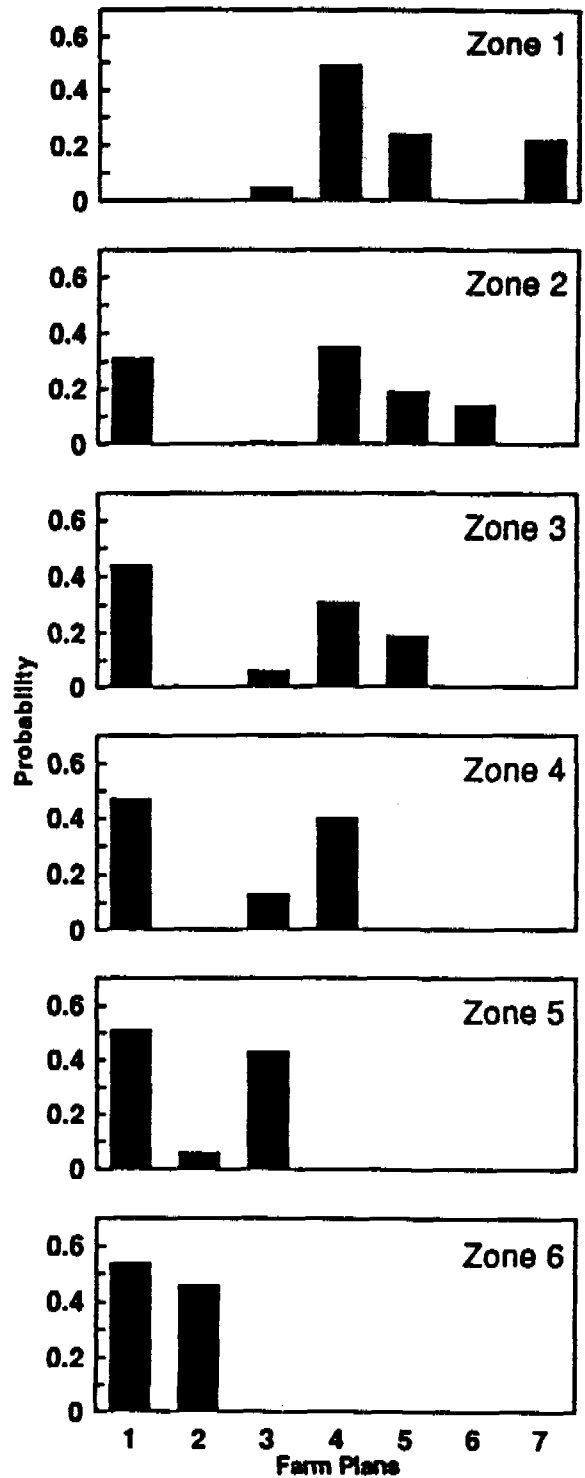

Figure 20. Probabilities that the Feasible Farm Plans will be Optimum in Year 1 of a 20-Year Planning Horizon. Each Plot represents a different Initial Reservoir Level (Approach 1)

Approach 2. The first approach identifies optimum selections based on perfect knowledge of future weather over the entire planning horizon. However, the "real world" works differently and thus weather uncertainty needs to be built into the analysis more directly. Once the decision maker has selected a farm plan for the first year, there will be no opportunity to re-adjust that decision based upon the weather of that year. Thus, it seems worthwhile to examine a scenario in which the initial farm plan is fixed, even though it may turn out to be non-optimum.

The results for three different planning horizons will be discussed. These planning horizons are three, five and ten years. For each planning horizon, only three initial reservoir levels will be depicted (zones 1, 3 and 5). Furthermore, for reasons of graphical clarity, the total number of farm plans in each figure will not exceed four.

The results for a 3-year planning horizon are in Figure 21a-c. The probability plots show the accumulated revenues over the planning horizon, based upon the initial reservoir zone and a particular farm plan in year 1. The revenue units are in millions of dollars, but for convenience will be referred to as "units" in the discussion. Figure 21a-c indicates that the variability among the accumulated revenues is greatest for an initially full reservoir (zone 1) and steadily declines as the beginning reservoir level decreases.

According to Figure 21a, there is a 30% probability that if farm plan 3 was selected for the first year, the accumulated revenue over the 3 years would be greater than or equal to approximately 42 units. If farm plan 7 or 5 would have been selected, that accumulated revenue would amount to about 44 units.

At that same probability level in zone 3, farm plan 1 would have been clearly inferior to farm plans 3 and 5 (farm plan 7 is no longer feasible). Proceeding to zone 5, farm plan 1 would have given slightly lower revenues (about 31 units) than farm plans 2 and 3 (about 32 units) at the 60% probability level. As expected, the revenues decline as the initial reservoir level decreases.

The results for a 5-year planning horizon are depicted in Figure 22a-c. Again the variability among farm plans is greatest for an initially full reservoir. For zone 1 (Figure 22a) there are some clear differences in the farm plans, but the curves are rather indistinguishable for zone 5 (Figure 22c). For zone 1, farm plans 1 and 3 are clearly inferior to farm plans 5 and 7.

The third planning horizon (10 years) is depicted in Figure 23a-c. When these plots are compared to those for the 3 and 5-year planning horizons (Figure 21a-c, Figure 22a-c), it is clear that the relative differences between the accumulated farm plan revenues are becoming smaller.

The impact of a "wrong" decision for the first year of the planning horizon is understandably greater in a 3- or 5-year horizon than in a 20-year horizon. The longer the planning horizon, the more years are available to compensate for the revenue loss in year 1.

Figure 24 shows how these types of probability-revenue curves could be further analyzed to aid the decision making process. This figure shows four farm plans which are feasible and consequently can be implemented if the reservoir level is in zone 1.

If the manager is interested in those farm plans which yield in 15% of the time

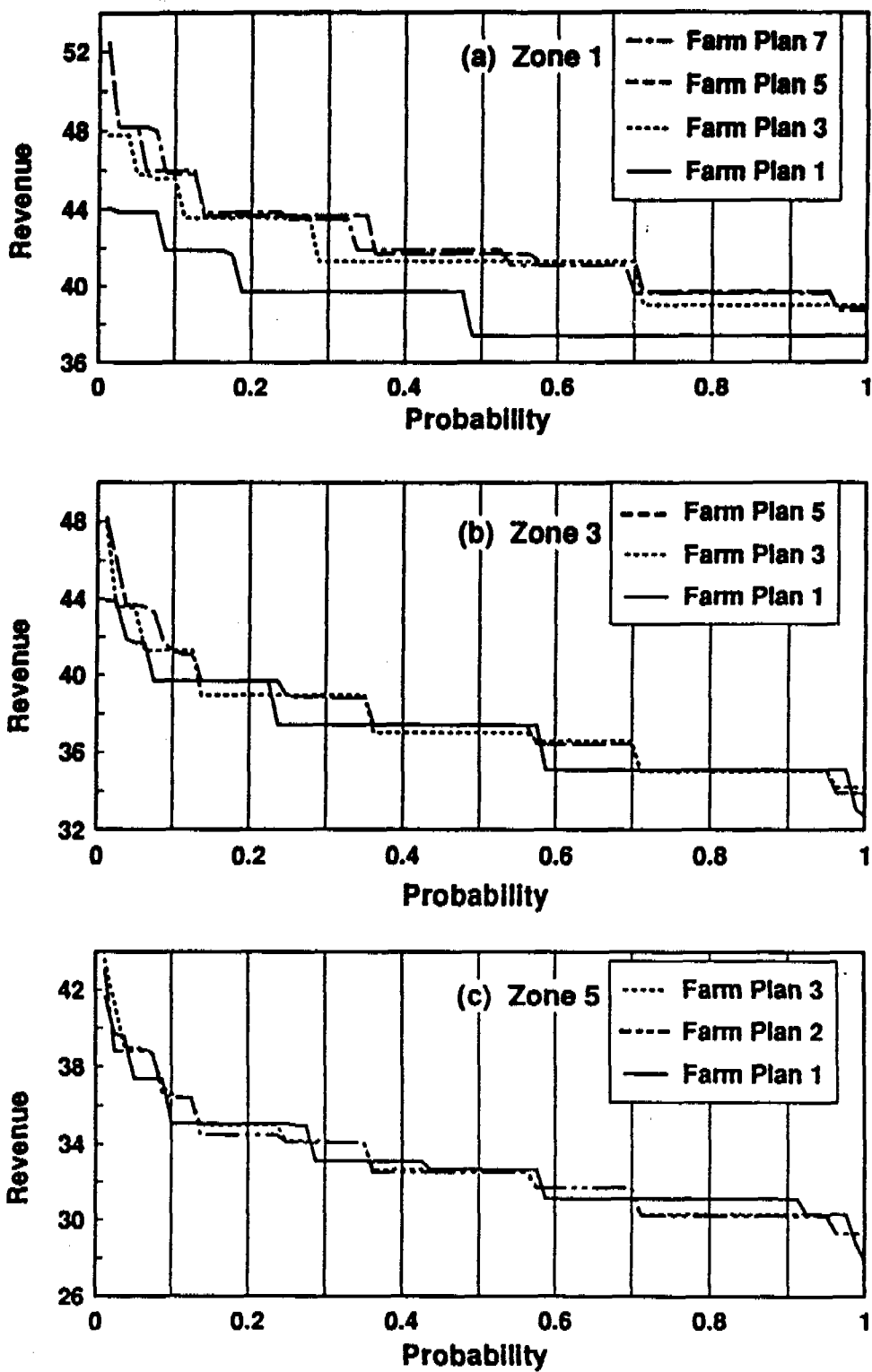

Figure 21. Probability-Revenue Curves for a 3-Year Planning Horizon for Three Initial Reservoir Levels and Selected Farm Plans in the First Year (Approach 2, 0% Discount Factor)

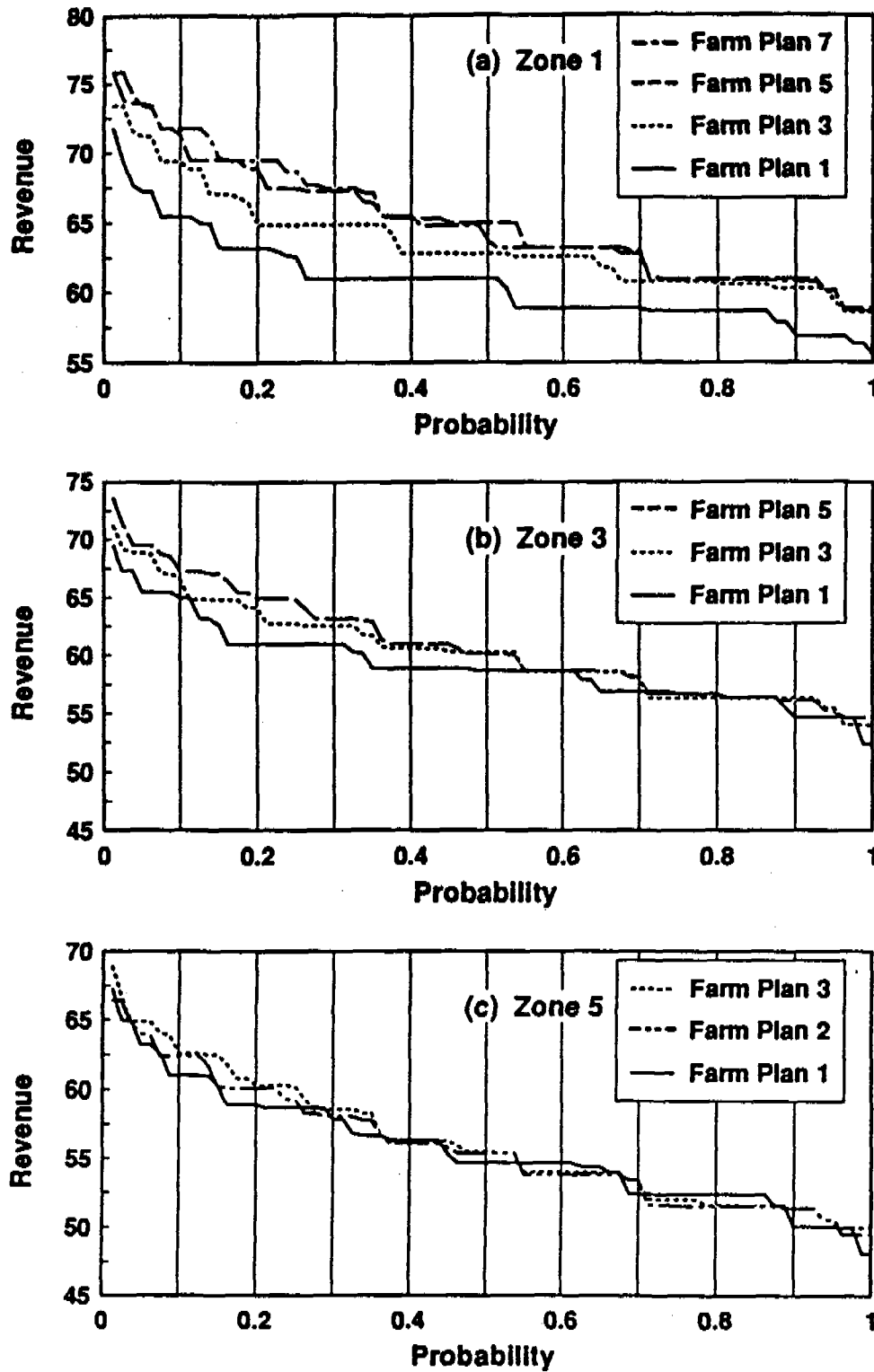

Figure 22. Probability-Revenue Curves for a 5-Year Planning Horizon for Three Initial Reservoir Levels and Selected Farm Plans in the First Year. (Approach 2, 0% Discount Factor)

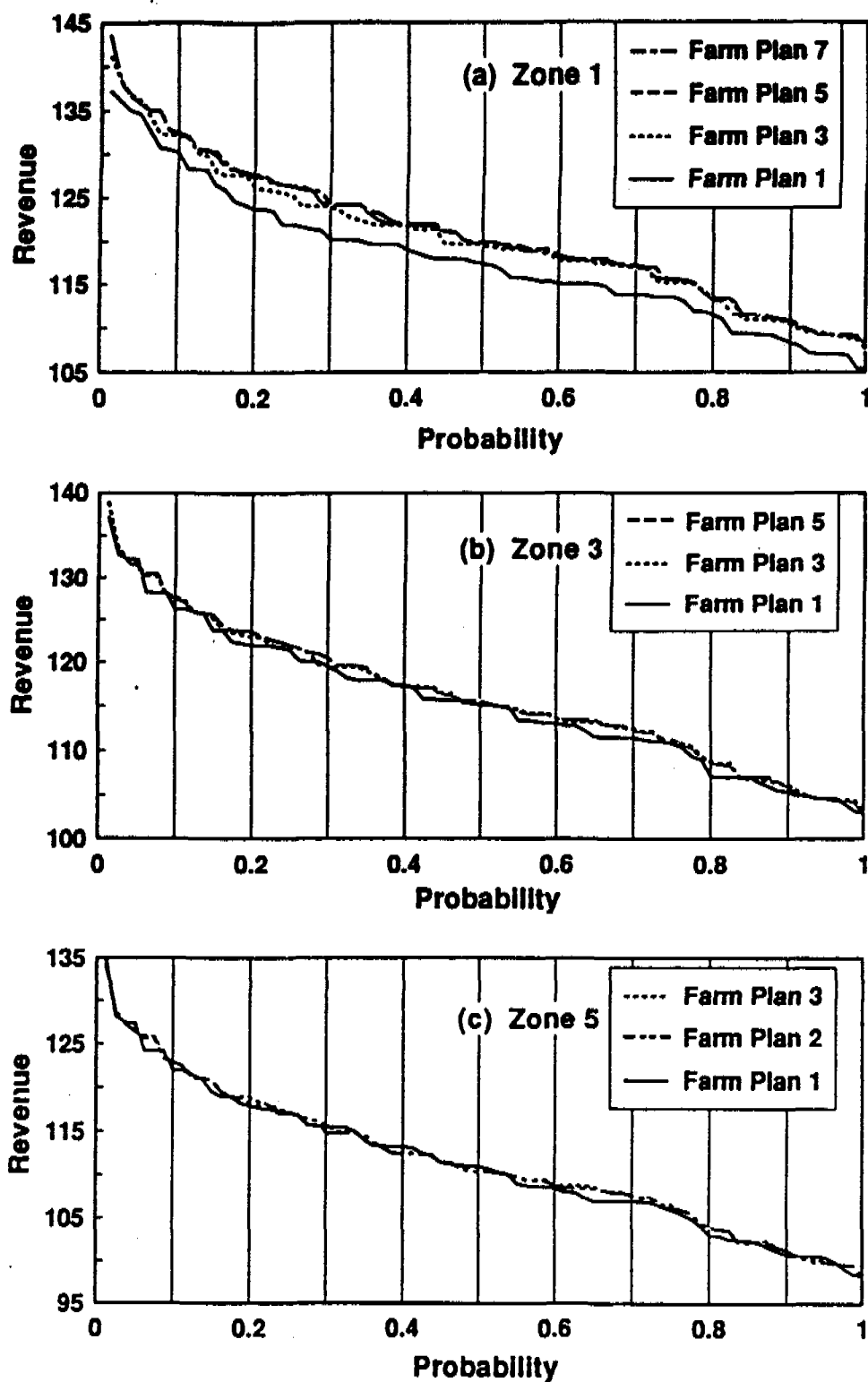

Figure 23. Probability-Revenue Curves for a 10-Year Planning Horizon for Three Initial Reservoir Levels and Selected Farm Plans in the First Year (Approach 2, 0% Discount Factor)

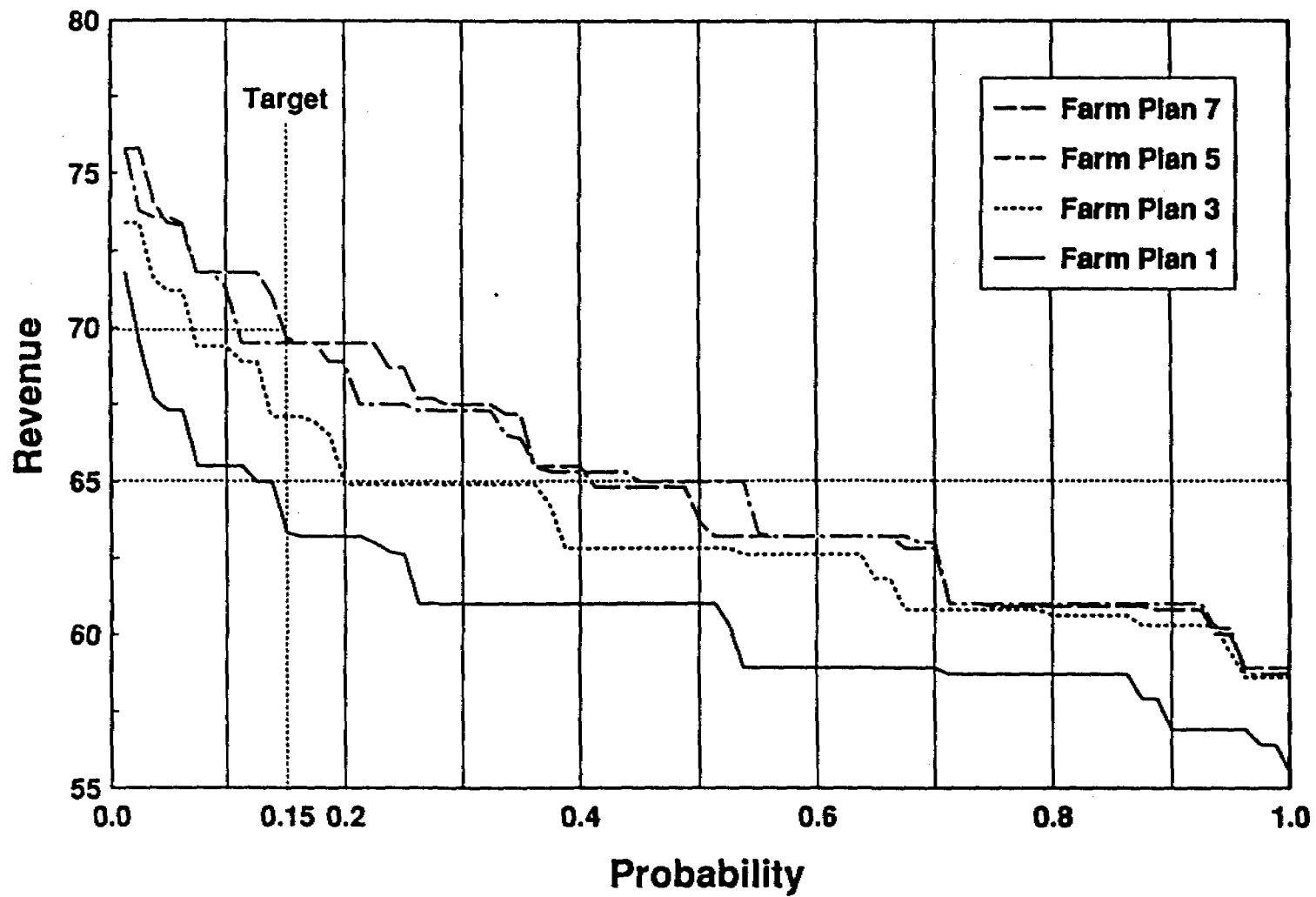

Figure 24. Detailed Analysis of Probability-Revenue Curves for 5-Year Planning Horizon for a Particular Initial Reservoir Levels and Selected Farm Plans in the First Year

70 units or higher, the manager should select farm plan 7. If that figure would be approximately 65 units, farm plans 3, 5 and 7 would meet that criterion. If the decision maker would be interested in minimum levels of income for the entire irrigation district, those plans with the highest minimum level (farm plans 3, 5 and 7) would be identified. Various types of "targets" can be used by the decision maker to screen the feasible farm plans. However, if the economic model was used to identify multiple "optimum" farm plans for a given water demand, or if the reservoir capacity was discretized into more zones, the number of feasible farmplans could greatly increase beyond the number used in this case study.

#### Other Sensitivity Analyses

The preceding method and discussion are all based on one major economic assumption; that the returns as calculated by the model are subject to a 0% discount factor. In other words, the model assigns equal weights to revenue accrued in the first year and the last year of the planning horizon. Under real-world conditions this assumption is not valid. Therefore, a sensitivity analysis was performed on the discount factor. Constant annual discount factors of 5, 20 and 60% were incorporated into the model. The 5% and 20% discount factors did not result in any significant changes in the positioning of the curves with respect to each other. The magnitudes of accumulated revenues did of of course decrease due to the discounting. The very high discount factor of 60% did have a significant effect. Figure 25a-c shows again the probability revenue curves for a zero discount factor and a 3-year planning horizon.

Figure 26a-c presents the results for the same zones but with a 60% discount



factor. In zone 1 (Figure 26a), the curves have become more separated (distinct) as a result of the high discount factor. The same effect is apparent in zone 3 (Figure 26b) but much less so in zone 5 (Figure 26c). For the upper zones of the reservoir the inclusion of the high discount factor has led to the selection of those farmplans with the highest feasible water demands. There is an incentive to allocate more water near the beginning of the planning horizon. Thus, incorporating a discount factor for future revenues has the same general effect as shortening the planning horizon.

For this particular case study, the hydrologic data for the catchment area suggest that about every 6 to 10 years the reservoir receives extreme inflows causing the reservoir to spill. The effect of different initial reservoir levels is essentially removed after such a refilling of the reservoir has taken place. After the reservoir has been filled, the optimum sequences are condensed to a single path. The shorter the planning horizon, the less chance there is that reservoir filling takes place and that optimal farm plan decisions are condensed (compare Figures 25 and 27). However, for the 60% discount factor, the probability revenue curves for shorter and longer planning horizons are very similar (compare Figures 26 and 28).

Another sensitivity factor which has been considered is the timing of the rainfall and runoff for the seasonally aggregated water balance. In all the previously discussed simulations the "optimistic" approach has been taken in that respect. The optimistic approach assumes that the rainfall and runoff anticipated during the the coming growing season are available for allocation during that irrigation season. The pessimistic approach makes available only the rainfall and runoff from the previous seasons. Simulations for 3, 5, 10 and 15 years did not show any significant sensitivity

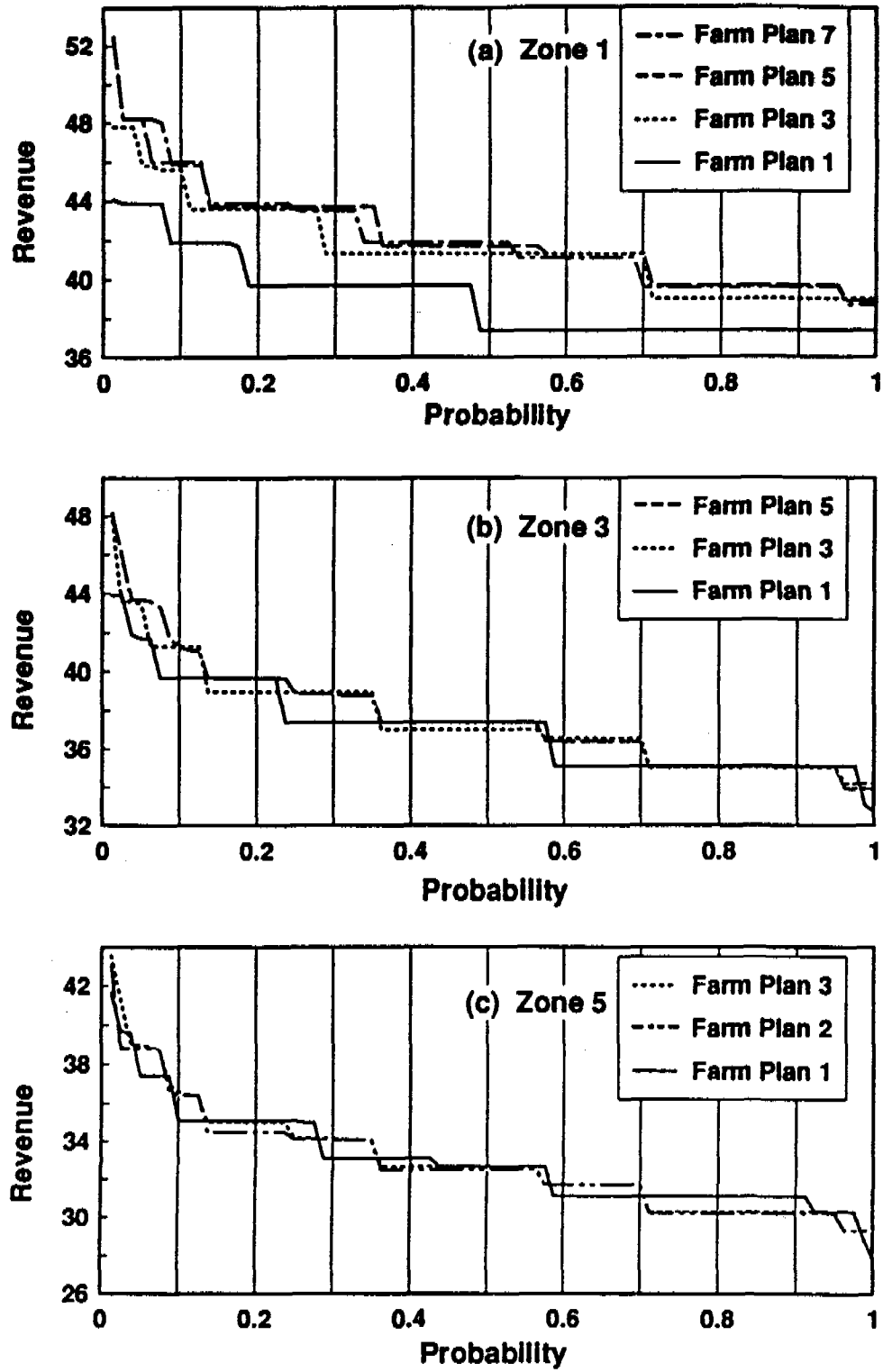

Figure 25. Probability-Revenue Curves for a 3-Year Planning Horizon for Three Initial Reservoir Levels and Selected Farm Plans in the First Year (Approach 2, 0% Discount Factor)

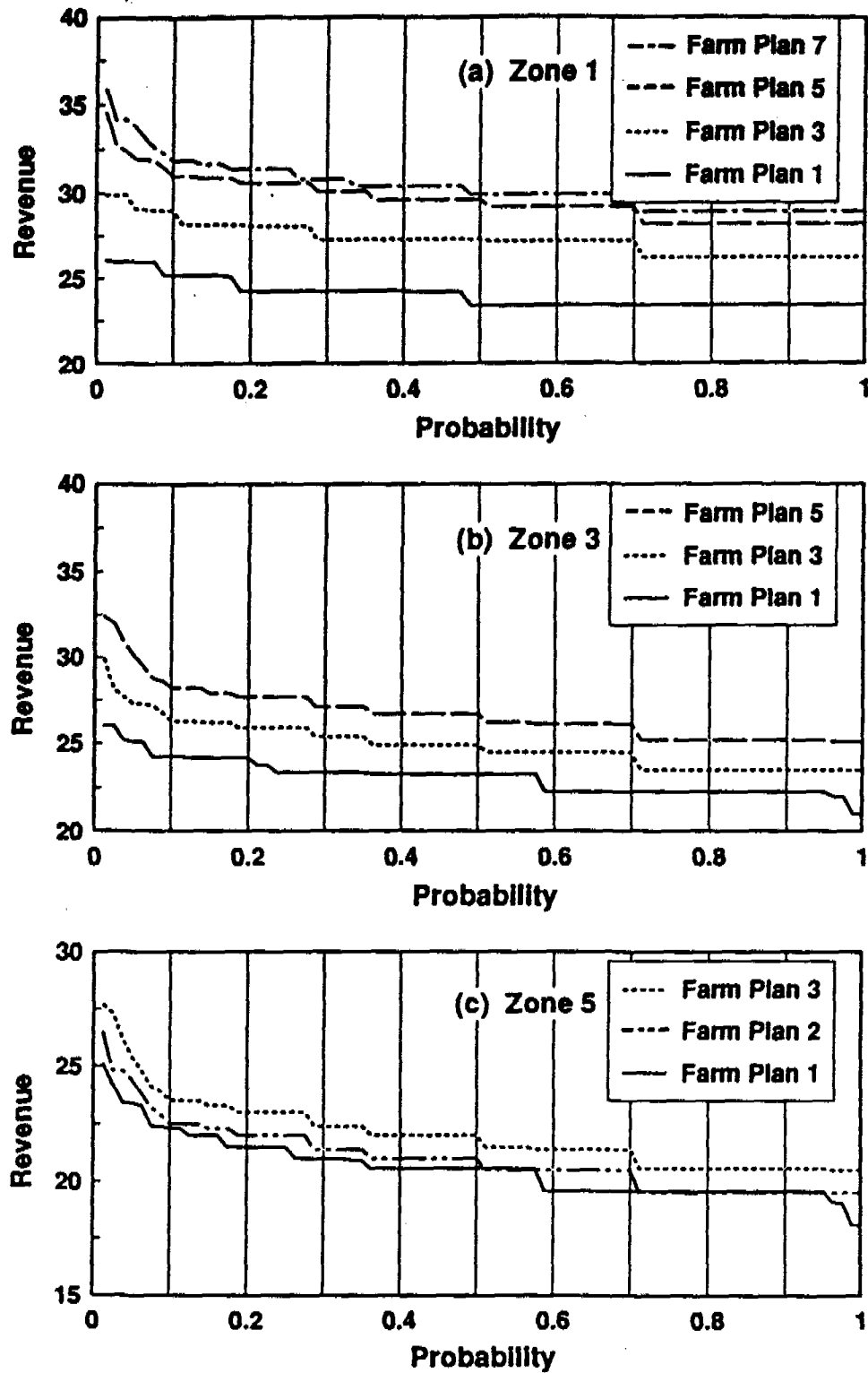

Figure 26. Probability-Revenue Curves for a 3-Year Planning Horizon for Three Initial Reservoir Levels and Selected Farm Plans in the First Year (Approach 2, 60% Discount Factor)

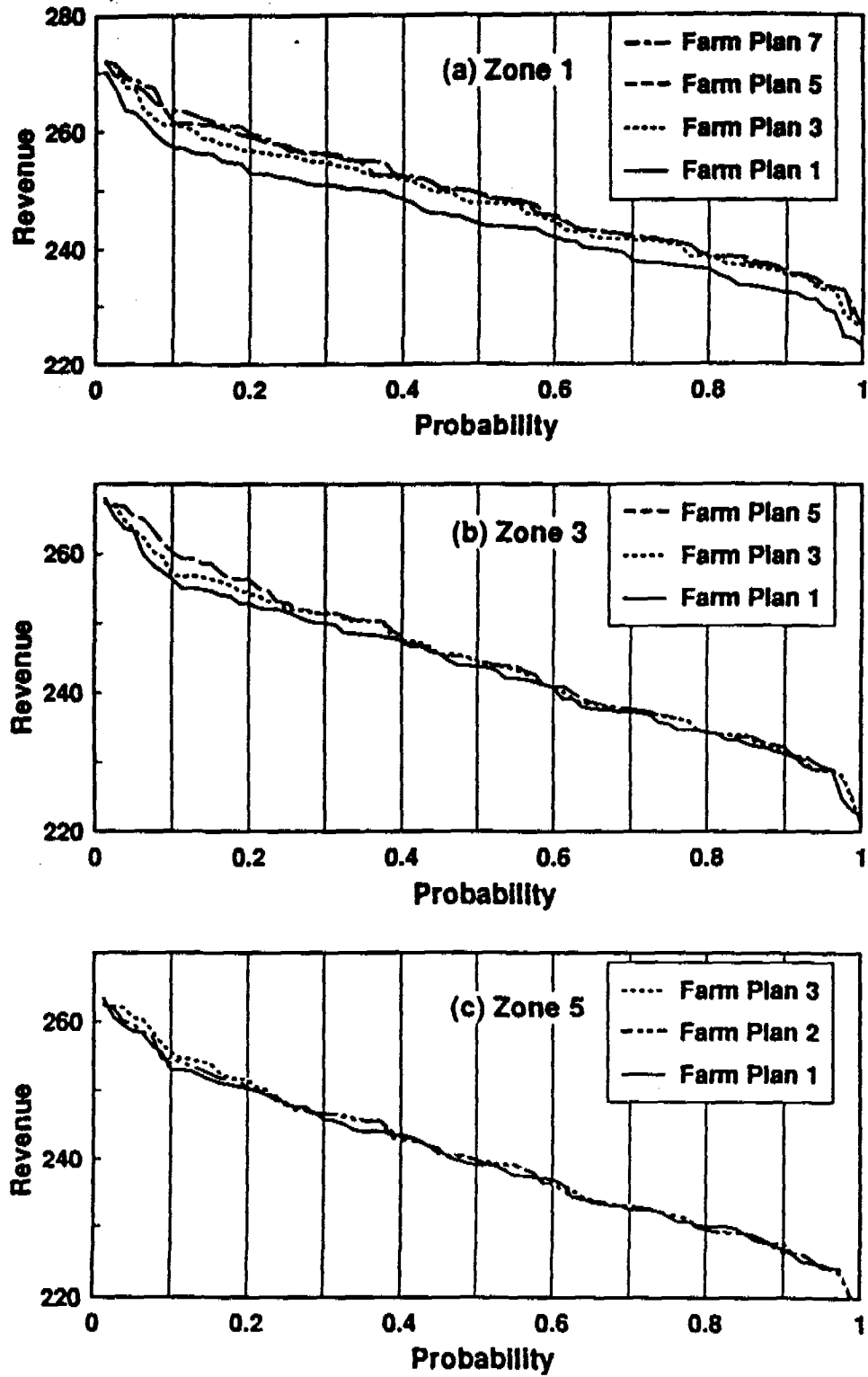

Figure 27. Probability-Revenue Curves for a 20-Year Planning Horizon for Three Initial Reservoir Levels and Selected Farm Plans in the First Year (Approach 2, 0% Discount Factor)

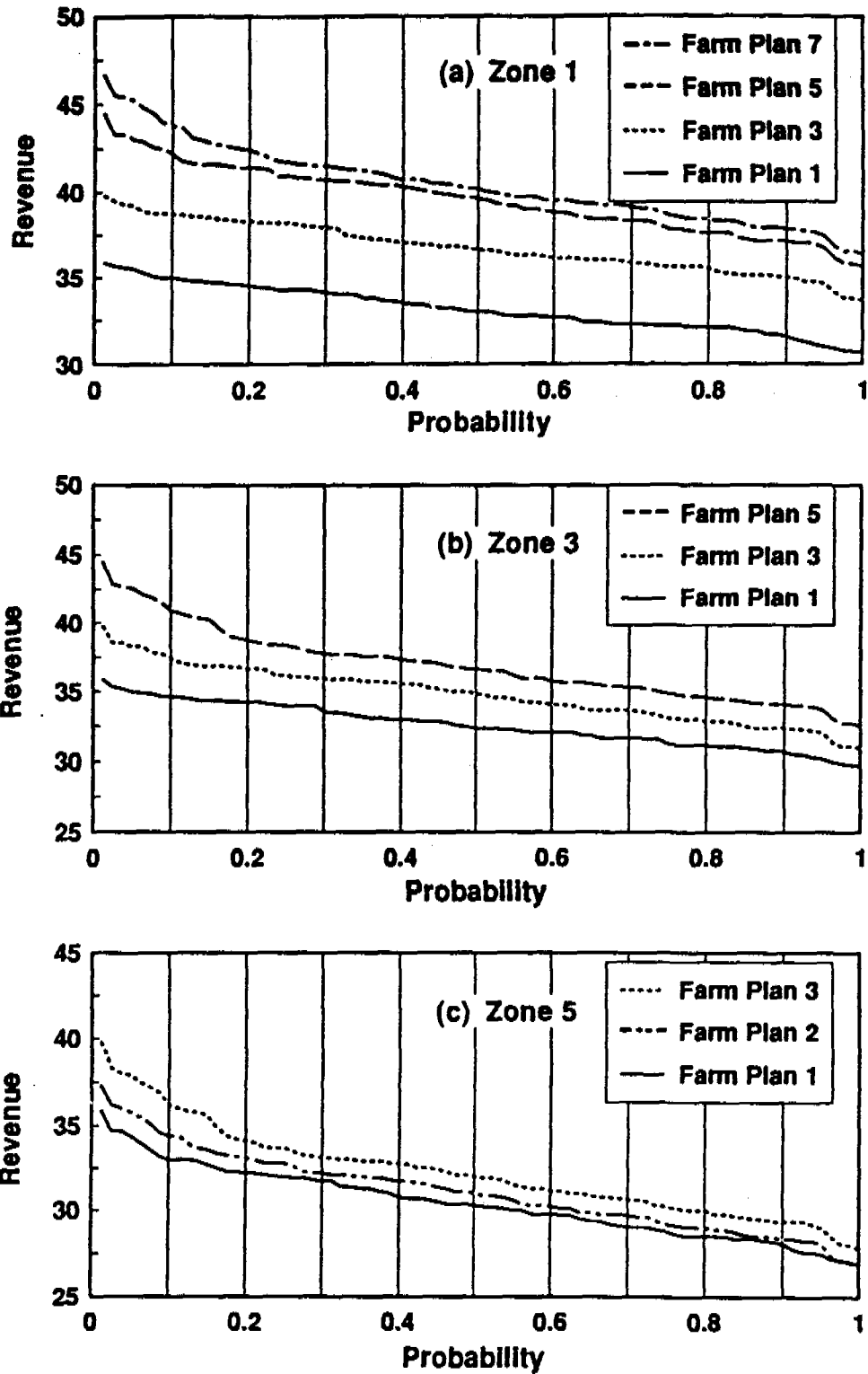

Figure 28. Probability-Revenue Curves for a 20-Year Planning Horizon for Three Initial Reservoir Levels and Selected Farm Plans in the First Year (Approach 2, 60% Discount Factor)

## CHAPTER VI

### SUMMARY AND CONCLUSIONS

The problem of optimal water allocation from an irrigation reservoir is an important issue which has received considerable attention in previous studies. The integrated approach presented here links four different models --- a hydrologic model (PRMS), a crop growth simulation model (EPIC), an economic model based on linear programming (LP), and a dynamic programming model (DP). The physical setting is an irrigation project located in a subhumid climate with an irrigation reservoir large enough for over-year storage. Deficit irrigation is being practiced.

Using a time series of weather data, EPIC provides annual yield estimates for various combinations of crops, soils, and irrigation strategies. These yield estimates are converted into net revenues through a farm budget which in turn is incorporated in the LP model along with physical constraints related to the irrigation system layout. The LP model identifies a set of optimal intra-seasonal farm plans (crop/land/water allocations); each one of the farm plans is uniquely associated with a particular water demand. This set of optimal farm plans together with their associated net revenues and water demands are then used in the DP model. This set of available intra-seasonal farm plans does not vary over the planning horizon, but a different plan can be selected in each year.

PRMS calculates deterministically a time series of runoff over the desired

planning horizon based upon a newly generated weather series. The runoff volumes are aggregated seasonally and used as an input to calculate reservoir levels for the DP model. The DP model then determines the optimal path through the planning horizon to achieve the highest possible revenue. By repeatedly looping through PRMS and the DP model, one can evaluate multiple realizations of the weather sequence over the planning horizon.

The approach provides guidance to a single decision maker on the allocation of crops and irrigation water to various land units at the start of the crop growing season. A case study with four land units and two crops has been used to test the integrated model and to demonstrate its utility. The approach is general in that it can accommodate a wide variety of physical scenarios.

Two different types of results are presented. The first provides the probability that each of the various farm plans (land/crop/water allocation) will be chosen as the optimum in the first year of the planning horizon. These probabilities are specified for each of several, discrete, initial reservoir levels. In interpreting the dynamic programming results, perfect knowledge of weather is assumed throughout the planning horizon.

The second approach provides probability distributions of accumulated revenues over a chosen length of planning horizon. Each distribution is associated with an initial reservoir level and a particular farm plan in the first year of the planning horizon. This approach recognizes that the weather in the first year (and of course beyond) is not known ahead of time and that the farm plan selected in the first year of the planning horizon may turn out to be non-optimum.

Several conclusions were drawn from the case study results. For the same planning horizon, as the initial reservoir level declined, the optimum farm plans tended to have lower water demands, the revenues tended to decrease, and the variability in the probability-revenue curves of the various plans tended to decrease. In other words, the farm plan decision tended to have greater economic consequence for a full reservoir than a reservoir which is partially depleted. With a full reservoir, one farm plan was more likely to dominate over competing ones, either partially or completely over the revenue range.

The results also showed that longer planning horizons tend to make the relative differences in accumulated revenues of the various farm plans less distinguishable. The longer planning horizon has the flexibility to compensate for a certain decision taken at the beginning of the planning horizon, while a shorter planning horizon has less time available to make that adjustment. The results suggested that planning horizons need not exceed 5 to 10 years for this particular case study.

In addition to analyzing the effects of planning horizon length, other sensitivity analyses have been performed. The inclusion of a discount factor on the probability-revenue curves had a significant effect only when the factor was quite high (60%); for each zone, it caused the farm plan alternatives to become more distinguishable and more dominant. In other words, applying a high discount factor had the same general effect as shortening the planning horizon.

Also examined was the assumed timing of rainfall and runoff for the seasonally aggregated water balance. There was essentially no difference in the results between the "optimistic" and "pessimistic" approach. The optimistic approach



assumes that rainfall and runoff occurring during the growing season are available for allocation at the beginning of that growing season. The "pessimistic" approach only allocates water which is in the reservoir at the beginning of the season.

In general terms, the proposed methodology provides an integrated model which reflects the entire physical and organizational setting, from the most upstream portion of the catchment area above the reservoir to the most downstream portion of the irrigated land area. The holistic approach allows a detailed analysis within one consistent framework. The consequence of selecting certain farm plans at the beginning of a specified planning horizon is quantified in a probabilistic way. Based on families of probability-revenue curves, a single decision maker can analyze all management options. The irrigation manager acting as a single decision maker has available an important tool which provides guidance for water release policies.

## CHAPTER VII

### RECOMMENDATIONS FOR FURTHER RESEARCH

This analytical technique should be applied to a variety of large scale, reservoir-dependent irrigation settings. An overall model which is more interactive would create a better user environment. It would also make it easier to analyze alternatives and perform sensitivity analyses.

In the economic modeling, various approaches can be used to identify "optimum" intra-seasonal farm plans. In this study conventional linear programming was used to screen the farm plans associated with the EPIC results. The farm plans are a condensed and aggregated representation of many factors and constraints used in the LP model as well as the crop growth simulation model. The LP model incorporates only an expected value from the time series of generated crop yields.

Economic theory could be employed to decrease the number of farm plans available to the decision maker. Based on attitude toward risk, stochastic dominance theory could be used to eliminate those farm plans which do not meet certain criteria (King and Robison, 1981; Zentner et al. 1981; Harris and Mapp, 1986).

Other methods exist which can identify candidate plans based on certain target levels or other criteria. For example, preliminary simulations have suggested that the TARGET-MOTAD technique (a variation of LP) could be successfully applied. Its main constraint is the method of screening a multitude of feasible solutions.

The capability of the crop growth model has not been fully incorporated. In fact, the use of EPIC is limited to the expected revenue associated with a certain crop/land/water allocation. Ideally, the distribution of annual revenues would be better utilized in the analysis. If that were the case, the weather sequence used in the upstream part of the catchment area would need to coincide with that used in the downstream irrigated area. This approach would result in new EPIC results (and thus new LP results) for each realization of weather over the planning horizon.

Aggregation of results from all runs could then present a challenge for proper interpretation.

The approach used has one single decision point for every season, when a crop is assigned to a certain land unit with a certain irrigation strategy. In order to be more flexible one could adapt this model in such a way as to allow for reassignment of irrigation strategies (or even crops) according to prevailing conditions or situations.

## BIBLIOGRAPHY

- Ahmed, J., C. H. M. van Bavel and E. A. Hiler. 1976. Optimization of crop irrigation strategy under a stochastic weather regime: a simulation study. *Water Resources Research* 12(6):1241-1247.
- Allred, B. and C. T. Haan. 1991. Variability of optimized parameter estimates based on observed record length. *Transactions of the American Society of Agricultural Engineers* 34(6):2421-2426.
- American Society of Agricultural Engineers. 1990. Visions of the future. *Proceedings of the Third National Irrigation Symposium, St. Joseph, Michigan, USA.*
- Bellman, R. 1957. *Dynamic programming*. Princeton University Press, Princeton, New Jersey, USA.
- Benedini, M. 1988. Developments and possibilities of optimization models. *Agricultural Water Management* 13:329-358.
- Blank, H. G. 1975. Optimal irrigation decisions with limited water. Ph.D. Thesis, Colorado State University, Ft. Collins, Colorado, USA.
- Boisvert, R.N. and B. McCarl. 1990. Agricultural risk modeling using mathematical programming. *Southern Cooperative Series Bulletin No. 356*, Department of Agricultural Economics, Cornell University, Ithaca, New York, USA.
- Boman, B. J. and R. W. Hill. 1989. LP operations model for on-demand canal systems. *Journal of Irrigation and Drainage Engineering* 115(4):687-700.
- Boote, K. J. , J. W. Jones, G. Hoogenboom, G. G. Wilkerson and S. S. Jagtap. 1989. PNUTGRO V1.02, peanut crop growth simulation model, user's guide. *Florida Agricultural Experiment Station Journal No. 8420*, University of Florida, Gainesville, Florida, USA.
- Bras, R.L. and J. R. Cordova. 1981. Intraseasonal water allocation in deficit irrigation. *Water Resources Research* 17(4):866-874.

- Cordova, J. R. and R. L. Bras. 1979. Stochastic control of irrigation systems. Technical Report 239. Massachusetts Institute of Technology, Department of Civil Engineering, Ralph M. Parsons Laboratory for Water Resources and Hydrodynamics, Cambridge, Massachusetts, USA.
- Crawford, N. H. and R. K. Linsley. 1963. A conceptual model of the hydrologic cycle. International Association of Scientific Hydrology. Publication No. 63, 573-587.
- Curtis, C. E., G. H. Pfeiffer, L. L. Lutgen and S. D. Frank. 1987. A TARGET MOTAD approach to marketing strategy selection for soybeans. North Central Journal of Agricultural Economics 9:195-206.
- Dariane, A. B. 1989. Operation of an irrigation reservoir by maximizing value of multiple crop yields. Ph.D. Thesis, Utah State University, Logan, Utah, USA.
- Dooge, J. C. 1972. Mathematical models of hydrologic systems. Proceedings of the International Symposium on Modeling Techniques. Water Resources Systems 1:171-189.
- Doorenbos, J. and A. H. Kassam. 1979. Yield response to water. Food and Agriculture Organization of the United Nations, Irrigation and Drainage Paper #33, FAO, Rome, Italy.
- Dudley, N. J. 1969. A simulation and dynamic programming approach for irrigation decision making in a variable environment. Ph.D. Thesis, University of New England, Armidale, New South Wales, Australia.
- Dudley, N. J. 1972. Irrigation planning 4: Optimal interseasonal water allocation. Water Resources Research 8(3):586-594.
- Dudley, N.J. 1988. A single decision-maker approach to irrigation reservoir and farm management decision making. Water Resources Research 24(5):633-640.
- Dudley, N. J., D. T. Howell and W. F. Musgrave. 1971a. Optimal intraseasonal irrigation water allocation. Water Resources Research 7(4):770-788.
- Dudley, N. J., D. T. Howell and W. F. Musgrave. 1971b. Irrigation planning 2: Choosing optimal acreages within a season. Water Resources Research 7(5):1051-1063.
- Dudley, N. J., W. F. Musgrave and D. T. Howell. 1972. Irrigation planning 3: The best size of an irrigation area for a reservoir. Water Resources Research 8(1):7-17.
- Dudley, N. J., D. M. Reklis and O. Burt. 1976. Reliability, trade-offs and water resources development modeling with multiple crops. Water Resources Research 12(6):1101-1108.

Foufoula-Georgiou, E. 1991. Convex interpolation for gradient dynamic programming. *Water Resources Research* 27(1):31-36.

Foufoula-Georgiou, E. and P. K. Kitanidis. 1988. Gradient dynamic programming for stochastic optimal control of multidimensional water resources systems. *Water Resources Research* 24(8):1345-1359.

Freund, R. J. 1956. The introduction of risk into a programming model. *Econometrica* 24:253-263.

Gagnon, C. R., R. H. Hicks, S. L. S. Jacoby and J. S. Kowalik. 1974. A non-linear programming approach to very large hydroelectric system optimization. *Mathematical Programming* 6:28-41.

Geigel, J. M. and W. B. Sundquist. 1984. A review and evaluation of weather-crop yield models. Staff Papers Series 84-5. Department of Agricultural and Applied Economics, University of Minnesota, St. Paul, Minnesota, USA.

Haan, C. T. 1977. Statistical methods in hydrology. The Iowa State University Press, Ames, Iowa, USA.

Haan, C. T., H. P. Johnson and D. L. Brakensiek. 1982. Hydrologic modeling of small watersheds. American Society of Agricultural Engineers, St. Joseph, Michigan, USA.

Hall, W. A. and J. A. Dracup. 1970. Water resources systems engineering. McGraw-Hill, New York, New York, USA.

Hanscom, M. L., L. Lafond, L. Lasdone and G. Pronovost. 1980. Modeling and resolution of the medium term energy generation planning problem for the Hydro-Quebec system. *Management Science* 26(7):659-688.

Harris, T. R., and H. P. Mapp. 1986. Stochastic dominance comparison of water conserving strategies. *American Journal of Agricultural Economics* 68:298-305.

Hazell, P. B. R. 1971. A linear alternative to quadratic and semi-variance programming for farm planning under uncertainty. *American Journal of Agricultural Economics* 53:53-62.

Hazell, P. B. R. and R. D. Norton. 1986. Mathematical programming for economic analysis in agriculture. Macmillan Publishing Company, New York, New York, USA.

Heidari, M., V. T. Chow, P. V. Kokotovic and D. D. Meredith. 1971. Discrete differential dynamic programming approach to water resources systems optimization. *Water Resources Research* 7(2):273-282.

Hexem, R. W. and E. O. Heady. 1978. Water production functions for irrigated agriculture. The Iowa State University Press, Ames, Iowa, USA.

Higgins, G. M., P. J. Dieleman and C. L. Abernethy. 1988. Trends in irrigation development, implications for hydrologists and water resources engineers. *Hydrological Sciences Journal* 33(1):43-59.

Horowitz, U. 1974. A dynamic model integrating demand and supply relationships for agricultural water, applied to determining optimal intertemporal allocation of water in a regional water project. Ph.D. Thesis, Iowa State University of Science and Technology, Ames, Iowa, USA.

IBSNAT. 1989. DSSAT user's guide, version 2.1. IBSNAT Project, Department of Agronomy and Soil Science, University of Hawaii, Honolulu, Hawaii, USA.

Jensen, M. E., W. R. Rangeley and P. J. Dieleman. 1990. Irrigation trends in world agriculture. in *Irrigation of Agricultural Crops*, eds. B. A. Stewart and D. R. Nielsen, 31-67, ASA/CSSA/SSSA, Madison, Wisconsin, USA.

Jenson, E. A. 1971. Programming models of irrigation development. Ph.D. Thesis, Iowa State University of Science and Technology, Ames, Iowa, USA.

Jones, J. W., K. J. Boote, S. S. Jagtap, G. Hoogenboom and G. G. Wilkerson. 1989. SOYGRO V5.42, soybean crop growth simulation model, user's guide. *Florida Agricultural Experimental Station Journal* No. 8304, University of Florida, Gainesville, Florida, USA.

Jones, J. W. and J. T. Ritchie. 1990. Crop growth models. in *Management of Farm Irrigation Systems*, eds. G. J. Hoffman, T. A. Howell and K. H. Solomon, 63-89, American Society of Agricultural Engineers, St. Joseph, Michigan, USA.

King, R. P., and L. J. Robison. 1981. Implementation of the interval approach to the measurements of decision maker preference. Research report No. 418, Michigan State University, East Lansing, Michigan, USA.

Kletke, D. D. 1989. Operation of the enterprise budget generator. Oklahoma State University, Agricultural Experiment Station Research Report P-790, Stillwater, Oklahoma, USA.

Leavesley, G. H., R. W. Lichty, B. M. Troutman and L. G. Saindon. 1983. Precipitation-runoff modeling system: user's manual. United States Geological Survey, Water Resources Investigations Report 83-4238.

Lee, E. S., K. S. Raju and A. W. Biere. 1991. Dynamic irrigation scheduling with stochastic rainfall. *Agricultural Water Management* 19:253-270.

- Le Moigne, G. J. M., H. Frederiksen and W. J. Ochs. 1989. Future irrigation prospects and actions in developing countries. *Journal of Irrigation and Drainage Engineering* 115(4):656-661.
- Markowitz, H. M. 1952. Portfolio selection. *Journal of Finance* 8:77-91.
- Martin, D. L. 1984. Using crop yield models in optimal irrigation scheduling. Ph.D. Thesis, Colorado State University, Ft. Collins, Colorado, USA.
- Matanga, G. B. and M. Marino. 1979. Irrigation planning 1. Cropping pattern; 2. Water allocation for leaching and irrigation purposes. *Water Resources Research* 15(3):672-683.
- Mawer, P. A. and D. Thorn. 1974. Improved dynamic programming procedures and their practical application to water resources systems. *Water Resources Research* 10(2):183-190.
- Moore, M.R. 1991. The Bureau of Reclamation's new mandate for irrigation-water conservation: purposes and policy alternatives. *Water Resources Research* 27(2): 145-155.
- Murray, D. and S. Yakowitz. 1979. Constrained differential dynamic programming and its applications to multi-reservoir control. *Water Resources Research* 15(4):1017-1027.
- National Oceanic and Atmospheric Administration. 1982. Evaporation atlas for the contiguous 48 United States. Technical Report, National Weather Service Report 33.
- Nopmonggol, P. and A. J. Askew. 1976. Multilevel incremental dynamic programming. *Water Resources Research* 12(6):1291-1297.
- Orth, H.M. 1986. Model-based design of water distribution and sewage systems. Wiley-Interscience, New York, New York, USA.
- Ozden, M. 1984. A binary state DP algorithm for operation problems of multi reservoir systems. *Water Resources Research* 20(1):9-14.
- Paudyal, G. N. and A. Das Gupta. 1990. Irrigation planning by multilevel optimization. *Journal of Irrigation and Drainage Engineering* 116(2):273-291.
- Rao, N. H., P. B. Sarma and S. Chander. 1990. Optimal multicrop allocation of seasonal and intraseasonal irrigation water. *Water Resources Research* 26(4):551-559.
- Rhenals, A. E. and R. L. Bras. 1981. The irrigation scheduling problem and evapotranspiration uncertainty. *Water Resources Research* 17(5):1328-1338.



Ritchie, J. T. , U. Singh, D. Godwin and L. Hurt. 1989. A user's guide to Ceres-Maize V2.10, International Fertilizer Development Center, Muscle Shoals, Alabama, USA.

Rogers, P. R. and M. B. Fiering. 1986. Use of systems analysis in water management. *Water Resources Research* 22(9):146S-158S.

Salas, J. D. and R. A. Smith. 1981. Physical basis of stochastic models of annual flows. *Water Resources Research* 17(2):428-430.

Singh, V. 1988. Hydrologic systems. Vol 1. Rainfall-runoff modeling. Vol 2. Watershed modeling. Prentice-Hall, Englewood Cliffs, New Jersey, USA.

Soil Conservation Service. 1988. Watershed plan and environmental assessment for Lugert Altus watershed, Jackson and Greer counties. United States Department of Agriculture, Stillwater, Oklahoma, USA.

Stillwater, L. C. 1990. An aggregate state dynamic programming formulation of a multiple reservoir system. Ph.D. Thesis. Department of Agricultural and Chemical Engineering, Colorado State University, Ft. Collins, Colorado, USA.

Tauer, L. W. 1983. Target MOTAD. *American Journal of Agricultural Economics* 65:606-610.

Tauer, L. W. 1988. The assessment of economic impacts of current and emerging agricultural technologies that affect water quality. A.E.Res 88-14. Department of Agricultural Economics, New York State College of Agricultural and Life Sciences, Cornell University, Ithaca, New York, USA.

Thanh, N. C. and A. K. Biswas. 1990. Environmentally-sound water management. Oxford University Press. Oxford, England.

Tsakiris, G. and E. Kiountouzis. 1984. Optimal intraseasonal irrigation water distribution. *Advances in Water Resources* 7:89-92.

Turgeon, A. 1981. Optimum short-term hydro-scheduling from the principle of progressive optimality. *Water Resources Research* 17(3):481-486.

United States Army Corps of Engineers. 1990. A preliminary assessment of Corps of Engineers' reservoirs, their purposes and susceptibility to drought. Research Document No. 33, Hydrologic Engineering Center, Davis, California, USA.

United States Geological Survey. 1954. Water loss investigation. Lake Hefner Studies, Technical Report. United States Geological Survey Professional Paper 269.

United States Geological Survey. 1956. Water loss investigation. Vol 1-Lake Hefner Studies, Technical Report. United States Geological Survey Circular 229.

Vedula, S. and P. P. Mujumdar. 1992. Optimal reservoir operations for irrigation of multiple crops. *Water Resources Research* 28(1):1-9.

Viessman, W. Jr., G. L. Lewis and J. W. Knapp. 1989. Introduction to hydrology. Third Edition, Harper & Row, Publishers Inc., New York, New York, USA.

Whisler, F. D., B. Acock, D. N. Baker, R. E. Fye, H. F. Hodges, J. R. Lambert, H. E. Lemmon, J. M. McKinion and V. R. Reddy. 1986. Crop simulation models in agronomic systems. *Advances in Agronomy* 40:141-208.

Williams, J. R. 1983. The physical components of the EPIC model. Proceedings International Conference on Soil Erosion and Conservation, Honolulu, Hawaii, USA .

Williams, J.R., C. A. Jones and P. T. Dyke. 1984. A modeling approach to determining the relationship between erosion and soil productivity. *Transactions of the American Society of Agricultural Engineers* 27:129-144.

Williams, J. R. and K. G. Renard. 1985. Assessments of soil erosion and crop productivity with process models (EPIC). in *Soil Erosion and Crop Productivity*, ASA-CSSA-SSSA, Madison, Wisconsin, USA.

Yakowitz, S. 1982. Dynamic programming applications in water resources. *Water Resources Research* 18(4):673-696.

Yaron, D. and A. Dinar. 1982. Optimal allocation of farm irrigation water during peak seasons. *American Journal of Agricultural Economics* 64(2):681-689.

Yaron, D., G. Strateener, D. Shimshi and M. Weisbrod. 1973. Wheat response to soil moisture and the optimal irrigation policy under conditions of unstable rainfall. *Water Resources Research* 9(5):1145-1154.

Yeh, W. W. G. 1985. Reservoir management and operation models: a state-of-the-art review. *Water Resources Research* 21(12):1797-1818.

Yevjevich, V. 1987. Stochastic models in hydrology. *Stochastic Hydrology & Hydraulics* 1:3-22.

Yitzhaki, S. 1982. Stochastic dominance, mean variance and Gini's mean difference. *American Economic Review* 72:178-185.

Zentner, R. P., D. D. Greene, T. L. Hickenbotham and V. R. Eidman. 1981. Ordinary and generalized stochastic dominance: a primer. Staff Paper P81-27, Department of Agricultural and Applied Economics, University of Minnesota, St. Paul, Minnesota, USA.

## VITA

Armand J. M. Evers

Candidate for the Degree of

Doctor of Philosophy

Thesis: *OPTIMIZING INTRA- AND INTER-SEASONAL WATER ALLOCATION FROM AN IRRIGATION RESERVOIR SUBJECT TO STOCHASTIC INFLOWS*

Major Field: Agricultural Engineering

### Biographical:

**Personal Data:** Born in Heerlen, The Netherlands, 30th March 1956, the youngest son of Nicolaas J. Evers and Evaline C. M. Hartmans.

**Education:** Graduated from St. Bernardinus Atheneum Heerlen, The Netherlands in May 1974; received Bachelor of Science Degree in Tropical Land Water Use from the Agricultural University at Wageningen, The Netherlands in September 1979 and ir-degree (equivalent to Master of Science degree) in 1982 from the same university. In August 1989 he started his Ph.D. program and in December 1992 completed all the requirements for Doctor of Philosophy at the Oklahoma State University, Stillwater, Oklahoma.

**Professional experience:** Junior Agronomist, FAO/UNDP Project, Ibarra, Ecuador: March 1979-February 1980;  
Consultant Hydrology, NUFFIC-project, Cebu-city, the Philippines, March-August 1980;  
Junior Irrigation Agronomist, Belgian bilateral agricultural development project, "El Pisque", Quito, Ecuador, Jan-Dec. 1981;  
Water Management Engineer, International Institute of Tropical Agriculture, Ibadan, Nigeria, March 1983-May 1984;  
Teamleader/Water Management Engineer, International Institute of Tropical Agriculture, Bida, Niger State, Nigeria, May 1984-April 1987;

Water Management/Construction Supervision Consultant,  
DHV-Consulting Engineers, Palopo, South-Sulawesi, Indonesia,  
May 1987-July 1989;

Graduate Research Assistant, Department of Agricultural Engineering,  
Oklahoma State University, Stillwater, Oklahoma, August 1989-  
December 1992.

Professional Organizations: Selected Member of Tau Beta Pi; the National  
Engineering Honor Society, October 1991.

Member of Alpha Epsilon; the Honor Society of Agricultural  
Engineers, March 1992.