



TECHNICAL GUIDELINES ON Twin Pit Pour Flush Latrines



Ministry of Urban Development
Govt. of India



Regional Water & Sanitation Division
UNDP / World Bank 323.1-92TE-12021

LIBRARY
INTERNATIONAL REFERENCE CENTRE
FOR COMMUNITY WATER SUPPLY AND
SANITATION (IRC)

Technical Guidelines on Design, Construction and Maintenance of Twin Pit Pour Flush Latrines



LIBRARY, INTERNATIONAL REFERENCE
CENTRE FOR COMMUNITY WATER SUPPLY
AND SANITATION (IRC)
P.O. Box 93190, 2509 AD The Hague
Tel. (070) 814911 ext. 141/142

BARCODE:

323.192TE

Ministry of Urban Development
Govt. of India

7572 12021



Regional Water & Sanitation Group - South Asia
UNDP/World Bank Water & Sanitation Program



सत्यमेव जयते

सीचव

SECRETARY

भारत सरकार
शहरी विकास मंत्रालय
GOVT. OF INDIA
MINISTRY OF URBAN DEVELOPMENT

नई दिल्ली - 110011, तारीख 1992
Dated New Delhi-110011 the 28th April, 1992

FOREWORD

The most appropriate technology is that which provides the most socially and environmentally acceptable level of service at the least economic cost. The low cost sanitation scheme using twin pit pour flush latrine is no exception. In view of the constraints of resources and water scarcity and also to better environmental conditions by sanitary disposal of human excreta, the low cost sanitation programme is a useful alternative to achieve the objective.

The Government of India has launched an Integrated Low Cost Sanitation Scheme under the Liberation of Scavenger Programme wherein it has been proposed to provide low cost sanitation latrines on "whole town" basis to the 500 towns every year, having a population less than 5 lakhs during the Eighth Five Year Plan (1992-97). This gigantic task needs concerted efforts and close collaboration of a Group of Engineers, Social Scientists and Community Development Workers to achieve more effective results under this programme. The technical guidelines prepared by RWSG-SA, UNDP / World Bank Water and Sanitation Program will no doubt serve the programme implementors to a great extent. These guidelines have been prepared in a very systematic and objective manner so as to construct the low cost sanitation latrine without much of problems under different geographical and hydrological conditions. The approach adopted in these guidelines is very well understood even by beginners with little knowledge and training on low cost sanitation.

I hope that these technical guidelines will serve as an effective tool for the implementing authorities and will be used by them extensively for effective and efficient outcome of the programme of Government of India.

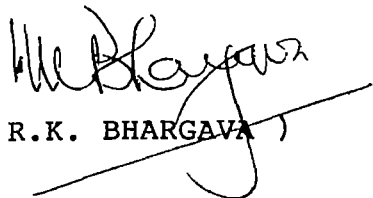
(R.K. BHARGAVA)

CONTENTS

1. Why Guidelines?	1
2. What is Twin Pit Pour Flush Latrine?	2
Drawing: Squatting Pan and Trap for Pour Flush Latrine	3
3. How to Design Leach Pits?	4
Sludge Storage Volume	4
Infiltration area	5
Pits in Water Logged, Flood Prone and High Sub Soil Water Areas	5
Drawing: Pour Flush Latrine in Waterlogged Area	6
Drawing: Pour Flush Latrine in High Sub-Soil Water Area	7
Pits in Snow Region	8
Pits in Rocky Strata	8
Pits in Soils with Low Infiltration Capacity	8
Pits Where Space is a Constraint	8
Drawing: Pour Flush Latrine with Combined Leach Pits	9
Size of Leach Pits	10
Shape of Pits	10
Location and Orientation of Pits	10
Spacing between Two Pits	10
Precautions	10
4. How to Construct Pour Flush Latrines?	11
Latrine Cubicle	11
Squatting Pan and Trap	11
Foot rests	11
Pit Lining	11
Pit Bottom	12
Distance of the Pits from Foundation	12
Pit Cover	12
Interconnection Between Pits and Squatting Pan	13
Latrine Superstructure	13
Drawing: Pit Lining with Dry RR Stone Masonry	14
Drawing: R.C.C. Cover for Leach Pits	15
Drawing: Junction Chamber and Brick Drain	16
5. What are the Pollution Safeguards?	17
Drawing: Leach Pits with Sand Envelope	18
6. How to Operate and Maintain a TPPF Latrine?	19
Diversion of Flow from One Pit to Another	19
Removal & Disposal of Pit Sludge	19
Do's	19
Dont's	20
7. What should the Supervisor Check during Construction?	21

List of Annexes

Annex 1.	Pour Flush Latrine with Dry Circular Leach Pits Size of Pits and Material Required for Construction	24
Annex 2.	Drawing: Pour Flush Latrine with Dry Circular Pits	25
Annex 3.	Pour Flush Latrine with Wet Circular Leach Pits Size of Pits and Material Required for Construction	26
Annex 4.	Drawing: Pour Flush Latrine with Wet Circular Pits	27
Annex 5.	Bill of Quantities for Pour Flush Latrine with Dry and Wet Circular Leach Pits	28

Why Guidelines?

Conventional water flush toilets are normally flushed with 10-14 litres of water from a cistern attached to it. In a Pour Flush (PF) latrine, as the name suggests, the excreta is “hand” flushed by pouring about 1.5 to 2 litres of water into the pan. In relation to conventional sewerage or septic tank, the PF latrine is a low cost sanitation system.

A manual on the Design, Construction and Maintenance of Pour Flush Latrines (TAG Technical Note No. 10) was published by the World Bank in 1984. Since then hundreds of thousands of PF latrines have been constructed all over India and in many other developing countries under different physical, geological and hydrogeological conditions. The Government of India has launched a massive programme to improve sanitation in urban and rural areas. It is difficult for field staff involved in these programmes to refer to a voluminous manual for day-to-day activities. Hence these Technical Guidelines have been prepared, covering the essential features of PF technology and the latest design improvements, based on past experiences. This is primarily meant for the ready reference of field staff on design, construction and maintenance of PF latrines.

What is Twin Pit Pour Flush Latrine?

Components

The PF latrine consists of

- a. a squatting pan of special design (Drawing on page 3) set on the floor;
- b. a trap with a 20mm waterseal, to prevent the emission of foul smell and fly/mosquito nuisance (Drawing on page 3);
- c. two leaching pits which retain solid matter and allow liquid to leach and gases to disperse into the ground; and
- d. an interconnecting system between pits and trap.
- e. a superstructure.

Functioning

The excreta is carried into subsurface leach pits through pipes or covered drains and one pit is used at a time. The liquid infiltrates into the soil through the holes in the pit lining. The gases also disperse into the soil, and therefore, the provision of a vent pipe for its outlet is not necessary. When one pit is full, the excreta is diverted to the second pit. The filled pit can be conveniently emptied after a rest period of one and a half years, during which pathogens are inactivated and the organic matter decomposed. Thus the two pits can be used alternately and continuously.

In a single pit system desludging is required immediately after the pit has filled up, and therefore involves handling of fresh and undigested excreta which is hazardous to health. Single leach pits are appropriate only if a mechanical desludging vacuum tanker is readily available, or if the pit is abandoned when full.

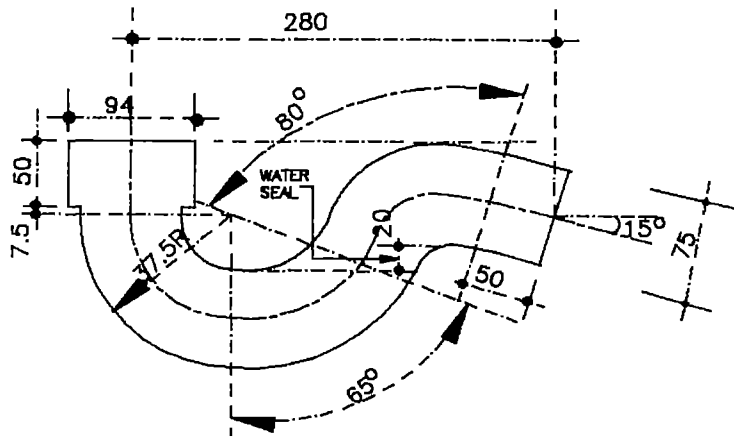

TRAP

Scale: 1:5

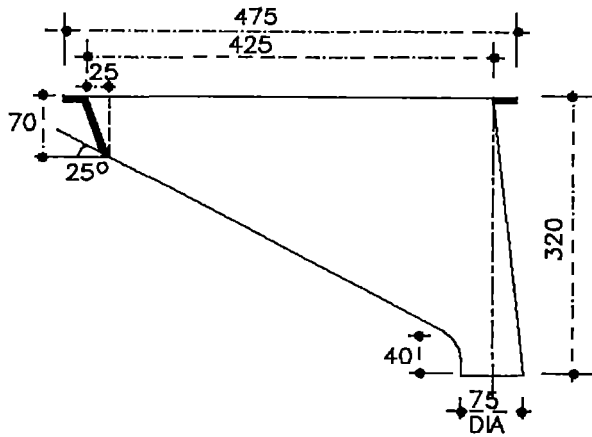

SECTION A-B

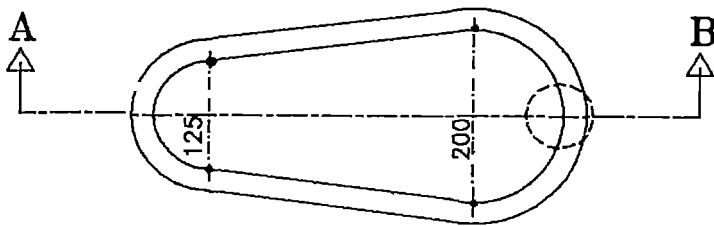

PLAN

SQUATTING PAN

Scale: 1:7.5

All dimensions in mm

SQUATTING PAN AND TRAP FOR POUR FLUSH LATRINE

How to Design Leach Pits?

The size of the leach pits is determined first on the basis of the volume required for storage of solid matter, and then it is checked whether it provides sufficient infiltrative surface area for infiltrating waste water to the surrounding soil. If it does not, the volume should be increased to provide adequate infiltrative surface area. A free space of at least 300 mm must be provided above the invert level of the inlet pipes or drains up to the bottom of the pit cover.

Sludge Storage Volume

The volume required is calculated on the basis of sludge accumulation rate, the number of persons likely to use the latrine, and the design sludge storage period.

$$\text{Storage volume needed} = \frac{\text{Sludge accumulation rate} \times \text{Number of users}}{\text{Design storage period}}$$

SLUDGE ACCUMULATION RATE

A leach pit is classified as wet or dry depending on whether the ground water table is above or below the bottom of the pit. In dry pits the storage volume needed is calculated only on the basis of sludge accumulation rate. But in wet pits even though the sludge accumulation rate is lower, the pit volume

has to be increased to prevent flooding due to surcharge. For designing pits, the volume needed per person per year is given below:

Table - 1
Pit Design-Volume Per Capita Per Year In cubic metres

Material used for anal cleansing	Dry pits	Wet pits ⁺ (2 year desludging interval)
Water	0.04*	0.078
Soft paper ⁺	0.053	0.104

Other anal cleansing materials such as hard paper, leaves, mud balls, corn cobs, etc. are unsuitable for use with PF latrines as they block the trap and the interconnecting pipes or drains.

NUMBER OF USERS

The number of persons likely to use the latrine varies from house-to-house, but to standardize construction details, pits are designed for 5, 10 and 15 users. If the users in the household are more than 15, it is better to provide two pairs of pits of appropriate size.

** Source: Report of the Committee on Design Criteria for Pour Flush Waterseal Latrines in Rural Communities of India - The Technology Advisory Group-India, March 1985, and Appropriate Sanitation Alternatives - A Planning and Design Manual by John M. Kalbermatten & others - World Bank Studies in Water Supply and Sanitation.*

+ For soft paper to be used for anal cleansing and wet pits, volume has been increased in the same proportion as in 'The Design of Pour Flush Latrines' by Duncan Mara - Technical Note No. 15.

STORAGE PERIOD

The minimum design interval between successive manual desludging of pits could be one and a half years which is the period required for inactivation of the most persistent pathogen present in faecal matter (*ascaris ova*). To allow for a reasonable degree of operational flexibility as well as to provide a safety factor, it is desirable to provide at least 2 year storage volume. However, if necessary, the pits can be designed for longer periods.

Infiltration Area

The area required for infiltration is calculated by taking into account the expected total daily flow to the pit and the long term infiltration rate of the soil where the pits are to be located.

$$\text{Infiltrative surface area required} = \frac{\text{Daily total flow to the pit}}{\text{Long term infiltration rate of soil}}$$

The vertical surface area of the soil in contact with the pit walls from the pit bottom to the invert level of the pipe or drain is to be considered for infiltration. The bottom of the pit is not taken into account for infiltration as it clogs in the course of time.

LONG TERM INFILTRATION RATE

The infiltration rate for different types of soil is taken to calculate the infiltrative surface area required as shown in Table 2:

Table - 2
Long Term Infiltration Rates for Different Soil Types*

Soil type	Litres per m ² per day
Sand	50
Sandy loam, loams	30
Porous silty loams, porous silty clay loams	20
Compact silty loams, compact silty clay loams, clay	10

FLOW TO THE PIT

Unless more specific data is available, flow to the pit is taken as 9.5 litres* per day per person. This includes urine, excreta, and water used for anal cleansing after defecation and flushing. The total flow in the pit is calculated by multiplying the expected number of latrine users by 9.5 and adding 5 litres⁺ for the water used for washing and cleaning the latrine floor and squatting pan.

Pits In Water Logged, Flood Prone and High Sub-soil Water Areas

In high sub-soil, water logged or flood prone areas, the pits should be raised above the ground level to a height such that the invert of the incoming drains/pipes is just above the likely flood water or sub-soil water level. Raising the pipes will necessitate raising the latrine floor also.

In pits located in water logged or flood prone areas, earth should be filled and well compacted all around the pits in 1000 mm width and up to the top (Drawing on page 6). It is not necessary to raise the pits by more

* Source: *The Design of Pour Flush Latrines* by D. Duncan Mara - TAG Technical Note No. 15.

+ Source: *Report of the Committee on Design Criteria for Pour Flush Waterseal Latrines in Rural Communities of India. The Technology Advisory Group - India, March 1985.*

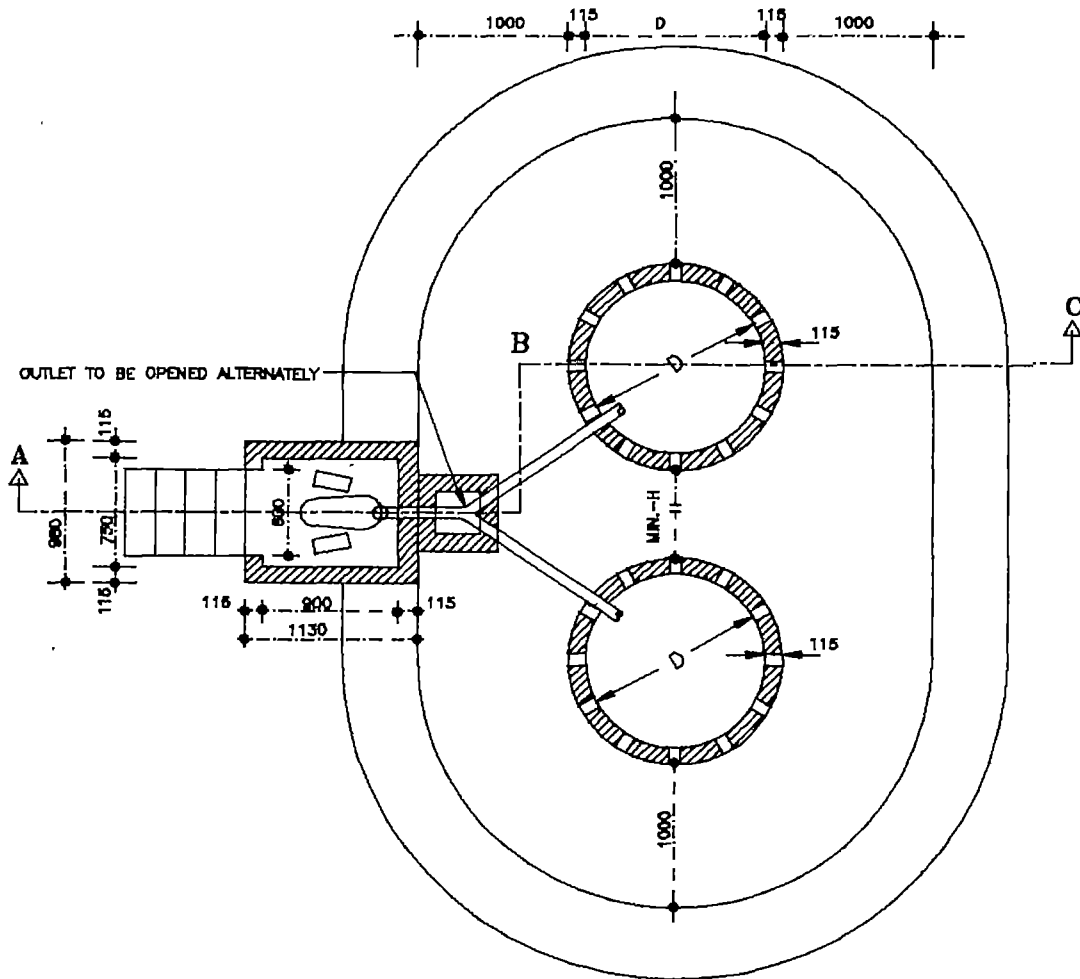
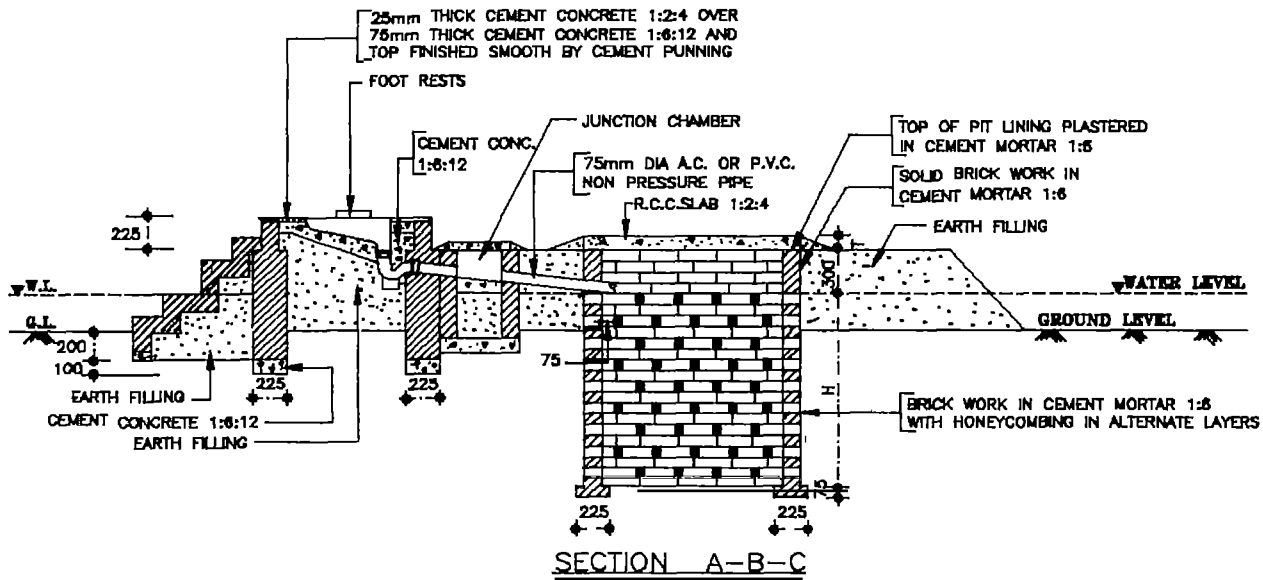

Scale: 1:50
All dimensions in mm

POUR FLUSH LATRINE IN WATER LOGGED AREAS

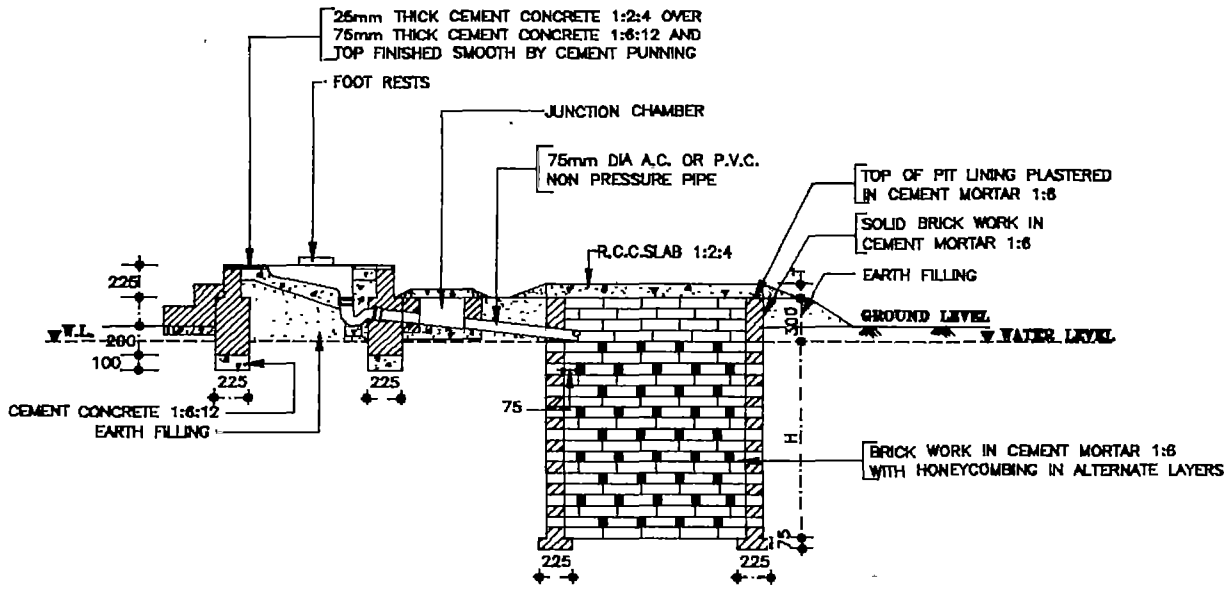

SECTION A-B-C

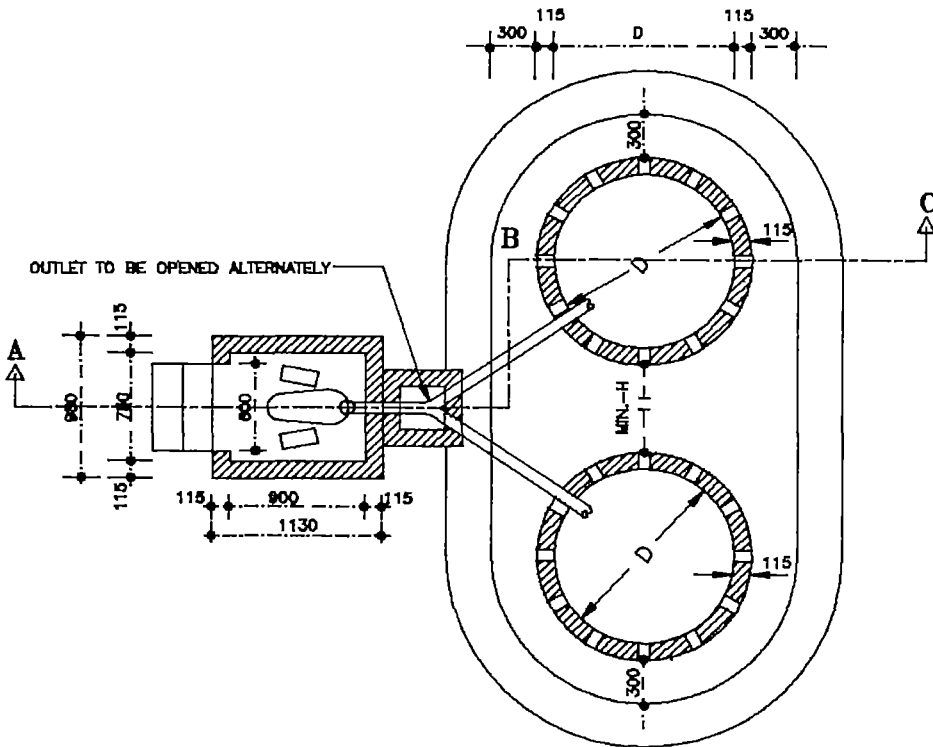

PLAN

NOTE:-

WATER TABLE LESS THAN 300mm BELOW GROUND LEVEL.

Scale: 1:50

All dimensions in mm

POUR FLUSH LATRINE IN HIGH SUB-SOIL WATER AREA

than 300 mm (free space as specified in page 4) above the plinth of the house because if water rises above the plinth, the residents will anyway vacate the house.

In high sub-soil water areas, about 300 mm filling all around the pits may be done depending on site conditions (Drawing on page 7).

In these situations, the pits should be designed as wet pits, taking into consideration the infiltration rate of the type of soil.

Pits In Snow Region

Experience has shown that PF latrines with twin pits function satisfactorily in areas subjected to snow fall in winter. The pits can be designed on the same considerations as those in the plains and should be constructed below the frost line.

Pits In Rocky Strata

In rocky strata with soil layers in between, leach pits are designed on the same principles as those for low sub-soil water level taking the long term infiltration capacity of the soil as 20 litres per sq.m per day. However, in rocks with fissures, chalk formations, or old root channels, pollution can flow over a very long distance; hence these conditions demand careful investigation and adoption of pollution safeguards (See page 17).

In impervious rocky strata, since there will be no infiltration of liquid, the pits will function as holding tanks. In such situations, a PF latrine with leaching pits is not a suitable system.

Pits in Soils with Low Infiltration Capacity

Leaching capacity tends to be the limiting factor when the infiltrative capacity of soil is low. In these circumstances, there are two options: construct a larger pit, or increase the critical leaching area. The former option is costly, while the latter can be accomplished by backfilling and compacting with brick ballast, gravel, sand etc., in the required width all around the pit, since the leaching area is the vertical surface of the excavation of the pit rather than the external wall of the pit (See page 5 under "Infiltration Area").

Pits in Black Cotton Soil are designed on the basis of whether the pit is wet or dry, taking the infiltration rate as 10 litres per sq. metre per day. However, a minimum 300 mm* vertical fill (envelope all around the pit) of sand, gravel or ballast of small sizes should be provided all round the pit, outside the pit lining, to separate the soil and the pit lining as well as to increase the infiltrative surface area.

Pits Where Space is a Constraint

Where circular pits of standard sizes cannot be constructed due to space constraint, deeper pits with smaller diameter (not less than 750 mm), or combined oval, square or rectangular pits divided into two equal compartments by a partition wall, may be provided. In case of combined pits, the partition wall, as well as the adjoining side walls up to 225 mm width, should not have any holes. The partition wall should be 225 mm deeper than the pit lining. Both faces of the partition wall should be plastered in cement mortar 1:6 (Drawing on page 9).

*Source: Final Report on Low Cost Waterseal Latrines in Urban Community by the Central Building Research Institute, Roorkee (India) - October 1980 - Study carried out under the UNDP Global Project GLO/78/006.

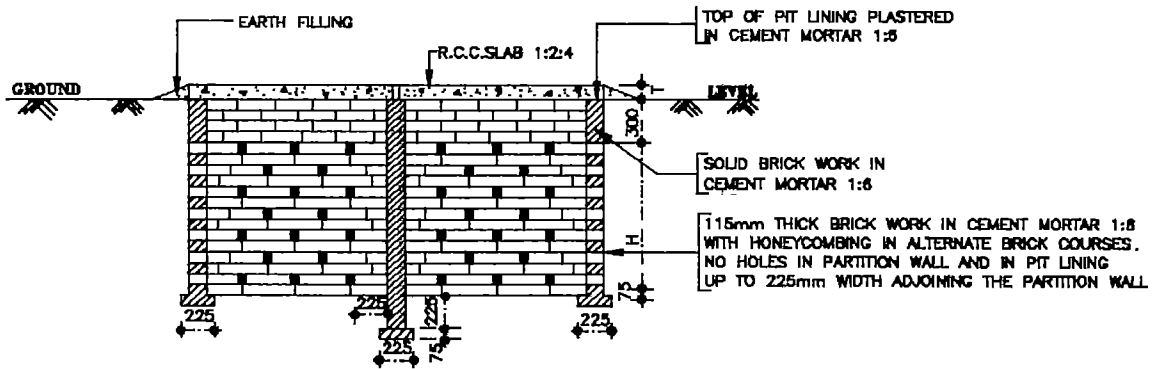

SECTION A-B

NOTE:-

THE SIZE OF HOLES IN HONEYCOMBING SHOULD BE 60mm WIDE AND FULL HEIGHT OF BRICK COURSE. IN SANDY SOIL OR WHERE THERE ARE CHANCES OF DAMAGE BY FIELD RATS OR WHERE SAND ENVELOPE IS PROVIDED, WIDTH OF HOLES BE REDUCED TO 12 TO 15mm

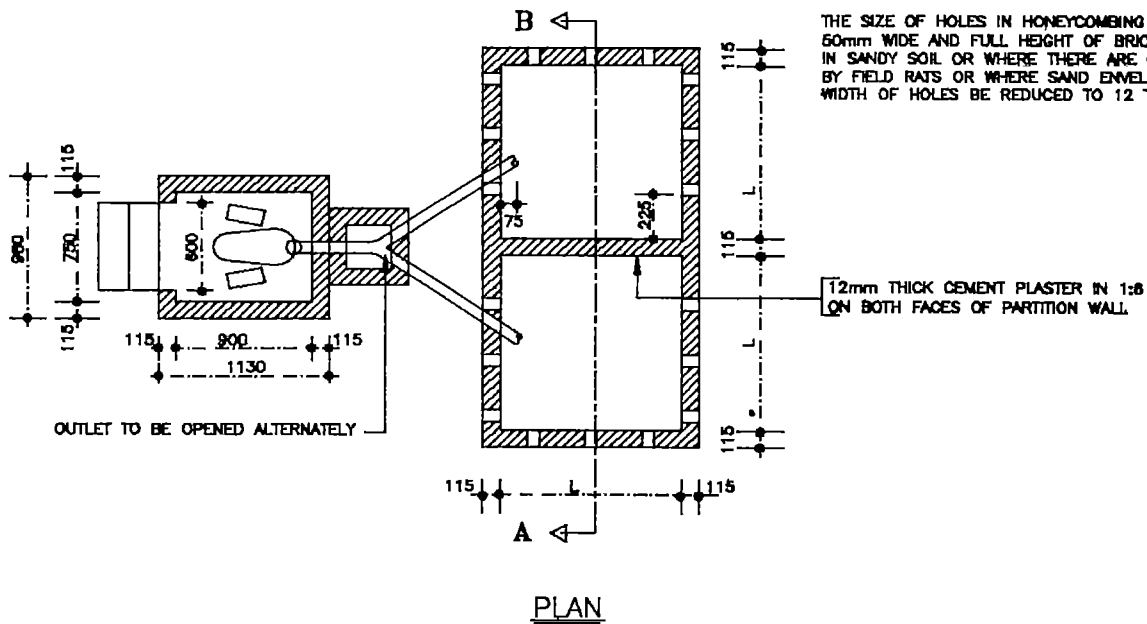

Scale: 1:50
All dimensions in mm

POUR FLUSH LATRINE WITH COMBINED LEACH PITS

Size of Leach Pits

The sizes of pits have been worked out for 5, 10 and 15 users (see page 4 under "No. of Users") assuming

- a. 2 year desludging interval (see page 4 under "Storage Period");
- b. volume needed for dry pits $0.04\text{m}^3/\text{cap}/\text{yr}$ and for wet pits $0.078\text{m}^3/\text{cap}/\text{yr}$ (see page 4 under "Sludge Storage Volume"),
- c. hydraulic loading $9.5\text{ l}/\text{cap}/\text{day}$ plus 5 litres for washing latrine floor (see page 5 under "Flow to the Pit"); and
- d. long term infiltration rate of soil 10, 20, 30 and $50\text{ l}/\text{m}^2/\text{day}$.

The sizes worked out are given in Annex 1 and Annex 3 (see page 24 and 26).

The depths given in the tables are effective depths measured from the invert of pipes or drains to the bottom of the pit. The total depth of the pit would be 300mm more than the depths specified in the tables, to allow for free space.

Shape of Pits

Wherever possible circular pits should be constructed because of their structural strength and relative larger surface area.

Location and Orientation of Pits

The pits, as far as possible, should be located within the premises of the house. However, if this is not possible, they can be

located under the street or foot path. In such cases, the pit cover should be designed to withstand the expected load which it will be subjected to.

Ideally, the pits should be placed symmetrically at the back of the squatting pan, as shown in the drawings on pages 7 and 9. If site conditions do not permit this layout, the pits can be located in any angle as long as drains/pipes are straight, are properly sloped with a minimum gradient of 1:15 and have no sharp bends.

Spacing Between Two Pits

The space between the two pits* should be at least the effective depth⁺ of the pit. If the spacing has to be reduced, an impervious barrier such as a cut-off screen or puddle clay wall should be provided between them.

Precautions

Wherever found necessary, the design should make provision for safeguards to prevent pollution of drinking water sources as specified on page 17.

* Source: *Manual on the Design, Construction and Maintenance of Low Cost Pour Flush Waterseal Latrines in India - TAG Technical Note No. 10;* and *The Design of Pour Flush Latrines by D. Duncan Mara - TAG Technical Note No. 15.*

+Effective depth is the depth of pit below invert of pipes or drains to bottom of pit.

How to construct Pour Flush Latrines?

Latrine Cubicle

The minimum internal size* of the latrine cubicle should be 750 mm from side to side and 900 mm from front to back. In firm soil the depth of the foundation should be as shown in drawings on pages 25 and 27. In loose or filled up or black cotton soil, the foundation should be designed as per site conditions. The plinth should be a minimum of 225 mm above ground level.

Squatting Pan and Trap

The pan could be of Ceramic, Glassfibre Reinforced Plastics (GRP), Cement Concrete (CC), Cement Mosaic, Poly Propylene (PP) or Poly Vinyl Chloride (PVC). Ceramic pans are the best but costliest. Mosaic or cement concrete pans have the advantage that they can be manufactured locally by trained masons, but they are heavy and the surface tends to become rough after long use. Their acceptance is lower than other types.

Traps for ceramic pans are made of the same material but for GRP pans, High Density Poly Ethylene (HDPE) traps are used. For mosaic and cement concrete pans, traps are of cement concrete.

The rim of the squatting pan should be installed horizontally and the trap connected

to ensure a 20mm waterseal. While fixing the trap, keep the top of the inlet and the top curvature of the trap horizontal; the squatting pan should then be fixed over the trap in such a way that its rim is horizontal and flush with the latrine floor. This process will ensure 20 mm waterseal in the trap. The distance between the pan and the back wall of the latrine superstructure should be about 200 mm.

Footrests

These can be of ceramic, cement concrete, cement mosaic or plastered brick. The top of the foot-rests should be about 20 mm above the floor level and inclined slightly away from the squatting pan in the front. Alternately foot rests can be an integral part of plastic or ceramic squatting pans.

Pit Lining

BRICK LINING

The pits should be lined to avoid collapsing. Bricks jointed in 1:6 cement mortar are most commonly used for lining. The thickness of the brick lining could be 75 mm, but due to poor acceptance and difficulty in construction, the lining is generally made 115 mm thick.

* Source: Manual on the Design, Construction and Maintenance of Low Cost Pour Flush Waterseal Latrines in India - TAG Technical Note No. 10.

SIZE OF HOLES IN BRICK LINING

The lining in the brick work should be by honey-combing up to the invert level of the incoming pipe or drain. The size of the holes should be about 50 mm wide, and extend to the full height of the brick course. For simpler construction, holes should be provided in alternate brick courses. If the soil is sandy or a sand envelope is provided or there are chances of damage by field rats, the width of the openings should be reduced to 12 to 15 mm (Drawing on page 18). Where the foundation of a building is close to the pit, holes should not be made in the portion of lining facing the foundation. However while designing pits in such a situation, the infiltrative area should be increased because less surface area would be available for infiltration due to brick work without holes. The lining above the invert of the pipes or drains, up to the bottom of the pit cover, should be in solid brick work, i.e. with no openings.

CEMENT CONCRETE RING LINING

The concrete rings used for lining should be 40 mm thick, about 300 mm in height and constructed with 1:3:6 cement concrete, reinforced with 2 rings of 6 mm dia mild steel bars. The first ring is placed after casting 50 mm of height and the second ring is placed at a height of 250 mm. Each ring should have two rows of 50 mm circular holes staggered about 200 mm apart. The rings are not to be jointed with mortar but are put one over the other. Below the pit cover two courses of brick work in cement mortar 1:6 should be provided for supporting the pit cover. The use of concrete rings is advantageous in the construction of wet pits.

BURNT CLAY RINGS

Where available, burnt clay rings of uniform deep cherry red or copper colour with holes can also be used for lining pits where they are not subjected to heavy pressures of loading.

STONE LINING

Stones or laterite bricks could also be used depending upon their availability and cost. Lining can be constructed in random rubble stone open jointed pitching (no mortar) with one layer at the bottom and the other in the middle, in cement mortar 1:6 (Drawing on page 14).

Pit Bottom

Except where precautions are to be taken to prevent pollution of drinking water sources (see page 17), the pit bottom should be left in a natural condition.

Distance of Pits from Foundation⁺

Pits up to 1.7 m depth can be safely located at a distance of 500 mm from the existing structure (distance between the foundation of the building to periphery of pit). For 2 m deep pits, a safe distance is 900 mm.

Pit Cover

Usually Reinforced Cement Concrete (RCC) 1:2:4 slabs are used for covering the pits, but depending upon the availability and cost, flagstones can also be used. The RCC slabs may be cast in two pieces for convenience of handling. The thickness of a RCC pit cover will depend upon the load

⁺Source: Final Report on Low Cost Waterseal Latrines in Urban Community by the Central Building Research Institute, Roorkee (India) - October 1980 - Study carried out under the UNDP Global Project GLO/78/006.

expected to come on it. For pits located inside the premises of the household, where they are not subjected to heavy loading, the thickness can be 50 mm but in such cases the covers should be centrally cast with stone ballast to ensure quality control. Brick ballast (of overburnt or first class bricks) can be used where stone ballast is not easily available and is costly, but the thickness of the slab should be increased to 75 mm.

The details of reinforcement in RCC pit covers are shown in the drawing on page 15.

Interconnection Between Pits and Squatting Pan

The trap is connected to the pit through a 75 mm brick channel of 'U' cross sectional shape covered with bricks jointed with weak mortar (for example mud) or cement mortar 1:12 (Drawing on page 16), or 75 mm dia A.C., or PVC non pressure pipe. In case pipes are used, a chamber of minimum size 250 mm x 250 mm (Drawing on page 16) should be provided at the bifurcation point to facilitate cleaning and allowing flow to the pit. In the case of a drain, the 'Y' portion of the drain serves the same purpose. The channel or pipe should have a minimum gradient of 1:15. The pipe or drain leading to the pit not in use should be completely sealed with a temporary plug, say of brick, stone or concrete etc., joined with weak mortar.

Latrine Superstructure

The superstructure should be designed to ensure privacy, convenience, comfort and easy maintenance. It should be well ventilated. It can be any of the following types in the case of a brick or concrete superstructure being unaffordable:

- i. White or colour washed jute, or thick plastic sheet enclosures on a bamboo frame;
- ii. Mud walls with a thatched or tiled roof;
- iii. Date palm or bamboo matting with bamboo frame and a thatched or tiled roof;
- iv. In the hills, walls of slates or small stone pieces and a roof of slates.

It is advisable to provide a superstructure along with the latrine substructure to ensure its immediate use.

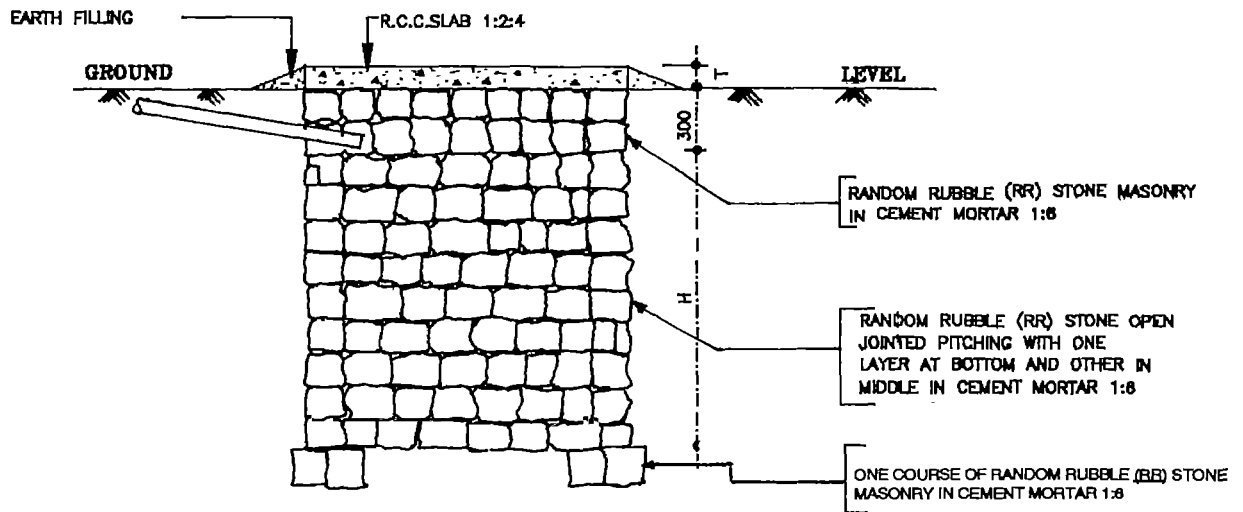

SECTION A-B

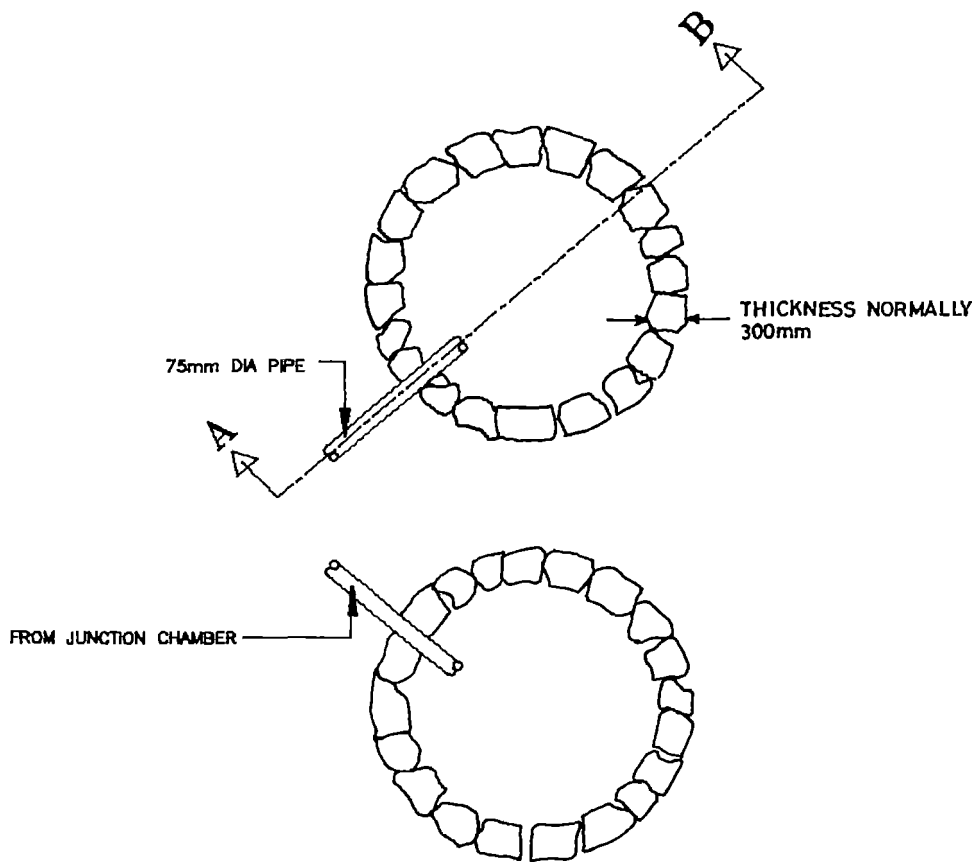

PLAN

Scale: N.T.S.
All dimensions in mm

PIT LINING WITH DRY RR STONE MASONRY

BAR SCHEDULE FOR ONE HALF COVER

DIA OF LEACH PIT (D)	NO OF BARS		SLAB THICKNESS
	HORIZONTAL	VERTICAL	
900	8	4	50
1200	10	5	60
1400	12	6	75

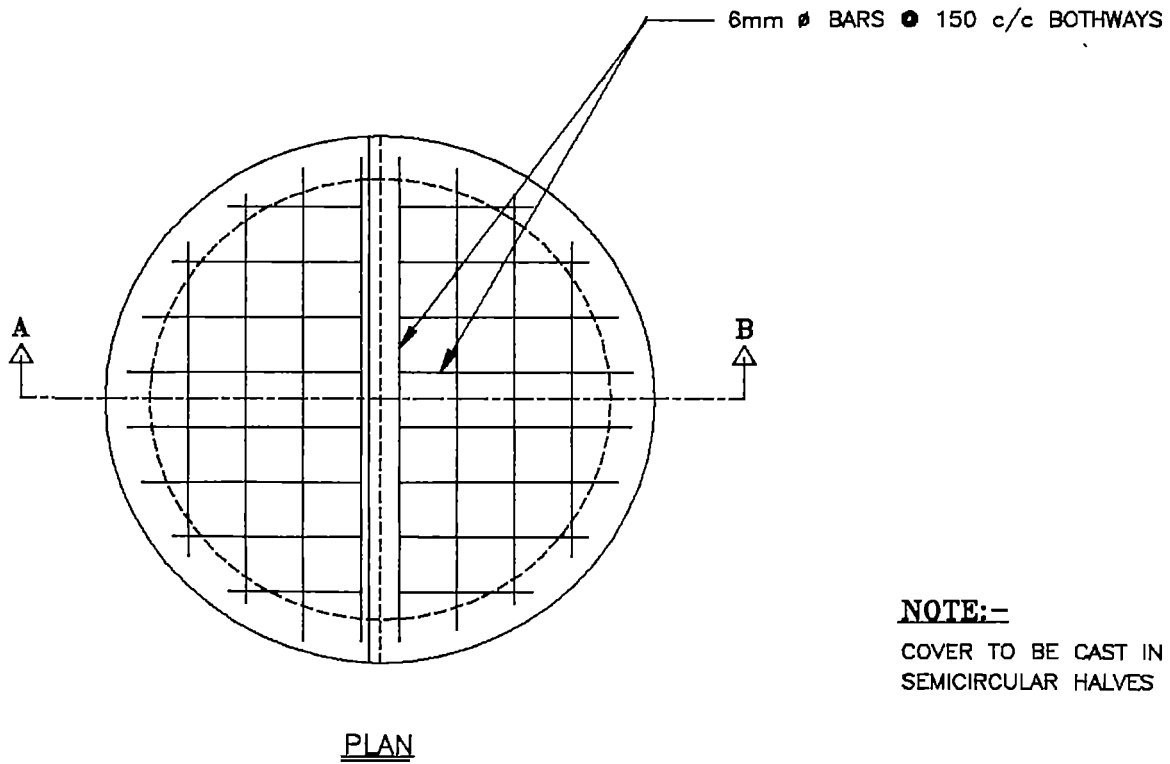
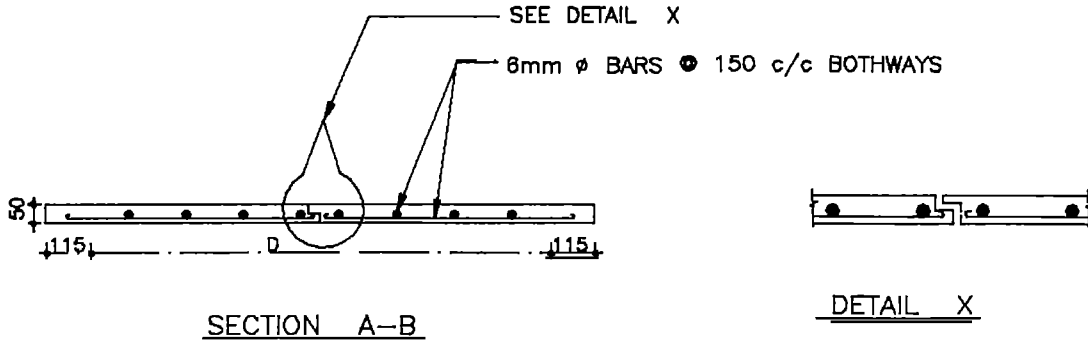

NOTE:-

COVER TO BE CAST IN TWO SEMICIRCULAR HALVES

Scale: 1:20
All dimensions in mm

RCC COVER FOR LEACH PITS

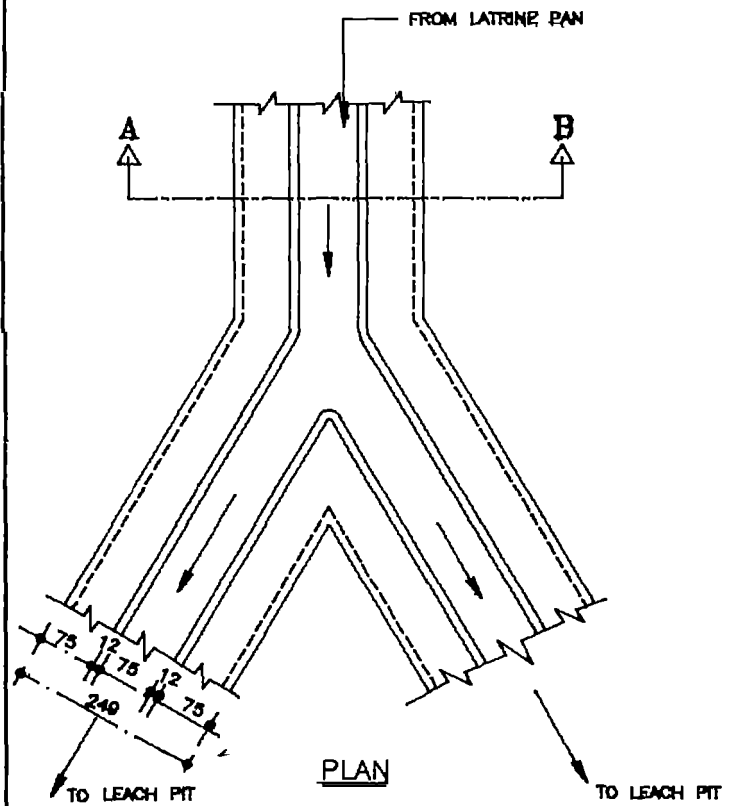
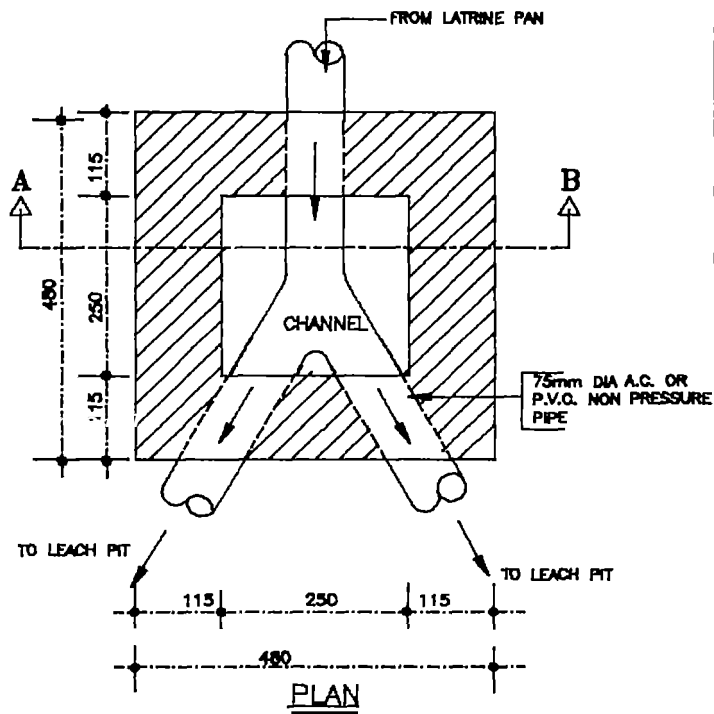
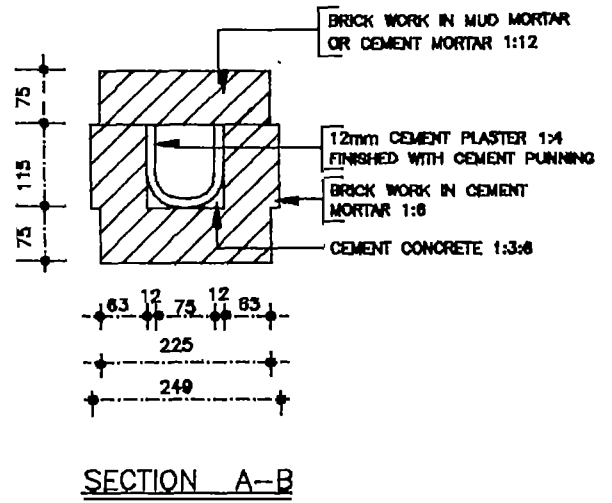
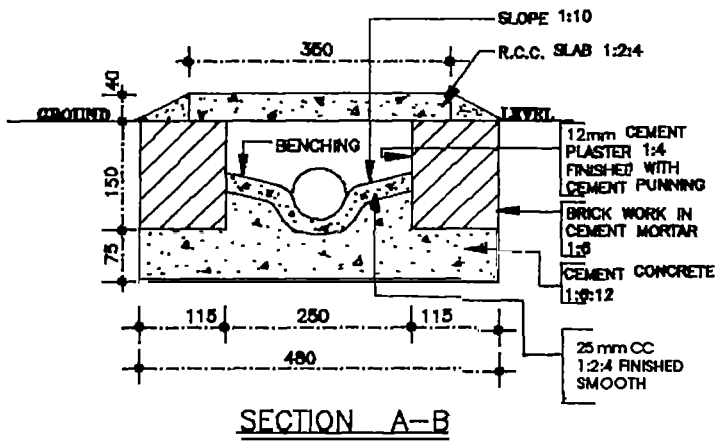

JUNCTION CHAMBER

BRICK DRAIN

Scale: 1:10
All dimensions in mm

JUNCTION CHAMBER AND BRICK DRAIN

What are the Pollution Safeguards ?

Proper information and investigation of both geological/hydrogeological conditions of sites where pits are to be located, and the location of drinking water sources, size, all are pre-requisites in planning, designing and construction of on-site low cost sanitation systems to ensure that pollution risk to ground water and water distribution mains is minimal. Faulty construction and wrong data/information regarding hydrogeological conditions may lead to pollution of drinking water sources.

To ensure that the risk of polluting ground water and drinking water sources is minimal, the following safeguards should be taken while locating the pits :

- a.** Drinking water should be obtained from another source or from the same aquifer but at a point beyond the reach of any faecal pollution from the leach pits.
- b.** If the soil is fine (effective size 0.2 mm or less), the pits can be located at a minimum distance of 3 m from the drinking water sources, provided the maximum ground water level throughout the year is 2 m or more below the pit bottom (low water table). If the water table is higher, i.e. less than 2 m below the pit bottom, the safe distance should be increased to 10m.
- c.** If the soil is coarse (effective size more than 0.2 mm), the same safe distances

as specified above can be maintained by providing a 500 mm thick sand envelope, of fine sand of 0.2 mm effective size, all around the pit, and sealing the bottom of the pit with an impervious material such as puddle clay, a plastic sheet, lean cement concrete, or cement stabilised soil (for sand envelope see Drawing on page 18).

- d.** If the pits are located under a footpath or a road, or if a water supply main is within a distance of 3 m from the pits, the invert level of the pipes or drains connecting the leach pits should be kept below the level of the water main, or 1m below the ground level. If this is not possible due to site considerations, the joints of the water main should be encased in concrete.

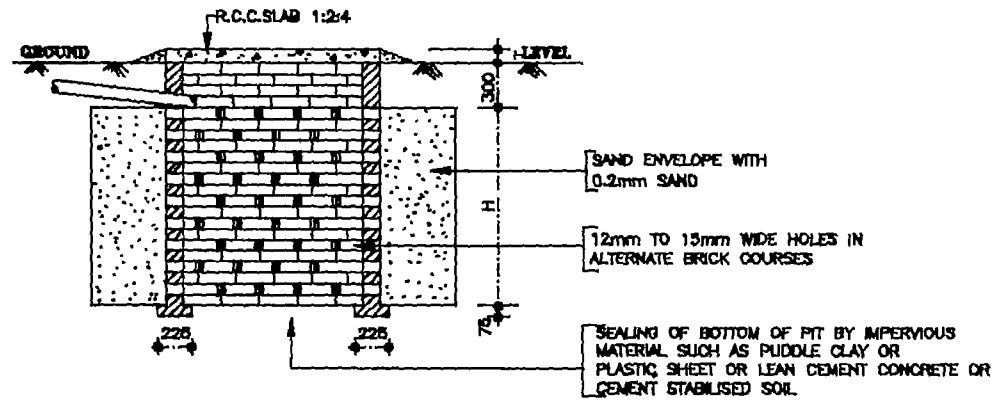

SECTION A-B

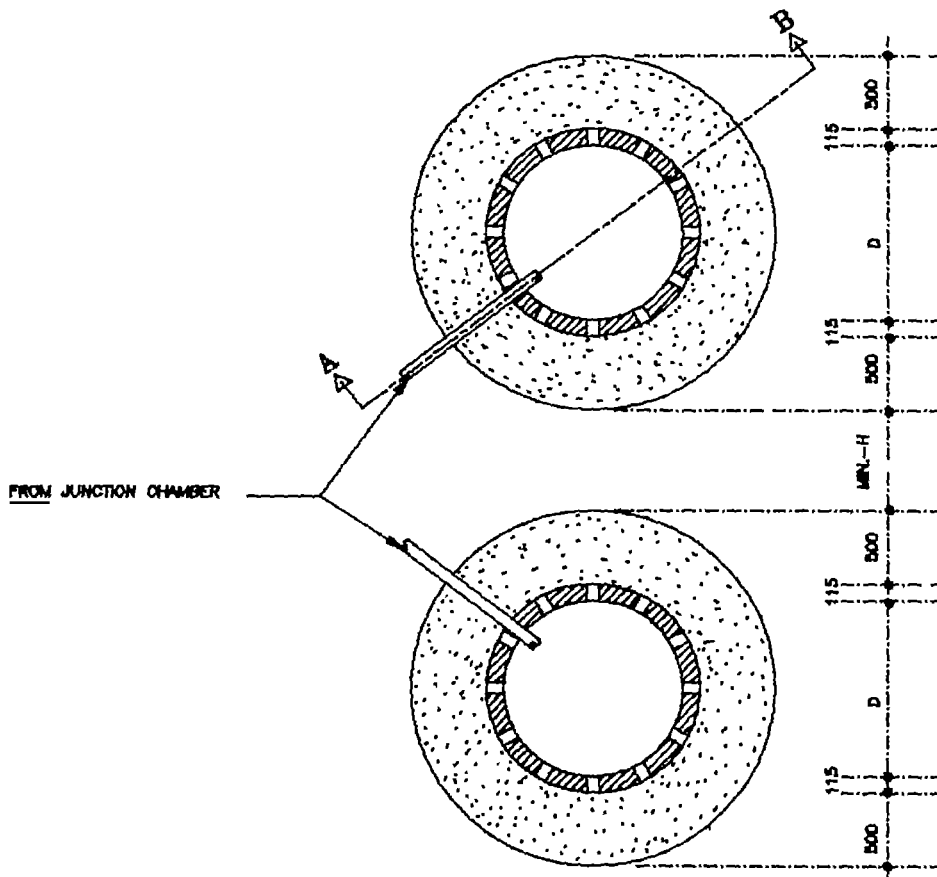

PLAN

NOTE:-

SEALING OF BOTTOM AND SAND ENVELOPES TO BE PROVIDED WHERE MINIMUM SAFE DISTANCE FROM THE WATER SOURCE CANNOT BE MAINTAINED

Scale: 1:50
All dimensions in mm

LEACH PITS WITH SAND ENVELOPE

How to operate and maintain a TPPF Latrine ?

Operation and maintenance of TPPF latrine is very simple but it is necessary to educate the users regarding its proper use and maintenance.

Diverslon Of Flow From One Pit to Another

Only one of the two pits is to be used at a time. It is very important to completely seal the entry to the pit which is not in use. This is done by blocking one of the branches of the drain or in the case of a pipe, by blocking the mouth of one pipe at the junction chamber (see page 13). When water does not flow out of the pan, either there is chokage or the pit in use is full. If by rodding, the chokage is not removed, then the pit in use is full and the flow needs to be diverted to the second pit. For this, remove the cover of the drain or junction chamber and take out the blockage to allow the flow to the pit not in use and block the flow to the pit which is full. Cover the drain or the junction chamber properly so that foul smell is not emitted.

Removal And Disposal of Pit Sludge

When the filled pit is allowed to rest for a minimum of one and a half years, the pit contents are completely digested and free of foul smell. The pit can then be safely emptied manually, without being hazardous to health, by the householder himself or through the local authority or a private agency. However, in the case of combined

pits and pits locateu in water logged and high sub-soil water areas, de-sludging of pits should be done carefully because the sludge might not be completely safe and dry to handle due to travel of pathogens from the pit in use to the pit to be desludged. After the pit is emptied, the pit cover should be placed in position and the joint made air tight. The humus collected has rich manure value and is a good soil conditioner. The humus from dry pits can be used directly either in the kitchen garden or the fields, but from wet pits it can be used only when it is sun dried.

Do's and Dont's

The following Do's and Dont's should be explained to the users :

Do's

- * Keep a bucket full of water outside the latrine.
- * Keep a 2 litre can in the latrine filled with water for flushing.
- * Before use, pour a little quantity of water to wet the pan so that excreta slide smoothly into the pit.
- * Flush the excreta after each use.
- * Pour a little quantity of water, say half a litre, in the squatting pan after urination.

- * The squatting pan should be cleaned daily with a soft broom or soft brush with a long handle after sprinkling a small quantity of water and detergent powder.
 - * Use minimum quantity of water in washing the pan and latrine floor.
 - * Wash hands, using soap or ash, after defecation at the assigned place.
 - * If any construction defect is observed during the guarantee period, report the matter to the local authority or the construction agency.
 - * When the pit in use is full, divert the flow to the second pit as discussed on page 19.
 - * If the trap gets choked, rodding should be done from the pan side as well as from the rear side by means of a split bamboo stick, after removing the cover of the drain or junction chamber.
 - * Care should be taken when desludging the pits located in water logged or high sub-soil water areas and in the case of combined pits, as the humus may not be safe for handling.
- * Do not throw sweepings, vegetable or fruit peelings, rags, cotton waste, and cleaning materials like corn cobs, mud balls, stone pieces, leaves etc. in the pan or the pits.
 - * Do not allow rain water, kitchen or bath waste water to enter the leach pits.
 - * Do not provide water tap in the latrine.
 - * Do not throw lighted cigarette butts in the pan.
 - * Do not desludge the pit before one and a half years of its being out of use.

Don't's

- * Do not use both the pits at the same time.
- * Do not use more than 2 litres of water for each flushing (if the waste is not flushed with 2 litres, pour more water at the specific spots for flushing the waste).
- * Do not use caustic soda or acid for cleaning the pan.

What should the supervisor check during construction ?

During construction, the supervisor should check whether the following conditions have been met:

- * In the drawings 'H' is the depth of the pit below the invert level of connecting pipes or drain; not the total pit depth.
- * If the maximum ground water level throughout the year remains 2 m or more below the pit bottom, and if the soil at site is fine (effective size 0.2 mm or less), the pits have been located maintaining a minimum distance of 3 m from the drinking water sources. If the water table is higher, a minimum 10 m distance be kept to minimize the chances of pollution.
- * If the soil at the site is coarse (effective size more than 0.2 mm), a 500 mm thick envelope of fine sand of (0.2 mm effective size) has been provided all around the pit, its bottom sealed, it is located at a minimum distance of 3 m if ground water table in any part of the year is 2 m or more below the pit bottom. If the water table is higher, a minimum distance of 10m has been kept to prevent pollution of drinking water sources.
- * The pit size conforms to the geological and hydrogeological conditions and the likely number of users, and adequate leaching area has been provided, if necessary, by back filling for proper infiltration of incoming liquid into the pits. In cases where the foundation is very close to the pits, holes have not been provided in the portion of lining facing the foundation, and the leaching area has been increased suitably.
- * The minimum distance between the two pits is equal to the effective depth (depth of the pit below the invert of incoming pipe or drain) of the pits.
- * The pits have not been located in a depression where water may stagnate over the pits or in a drainage line which allows the flow of rain water over the pits.
- * The bottom of the leach pit has been left in a natural condition except where it is necessary to seal it to prevent pollution.
- * The RCC cover is of the thickness shown in drawing on page 15 and has been reinforced as per the design.
- * The top of the pit cover is about 50 mm above the natural ground level and the earth fill is well compacted all around the cover sloping to avoid a step being formed.
- * The drain is 'U' shaped, cross-sectionally and its inner surface is smooth.
- * Drains with benching have been properly provided in the junction chamber (Drawing on page 16) to divert the flow to one of the two pits.

- * A minimum gradient of 1:15 has been provided in the connecting drains or pipes.

The mouth of the drains or pipes is projecting nearly 75 mm past the pit lining in the pits.

- * The flow has been restricted to one pit by blocking the mouth of one of the drains or pipes.
- * The materials used are of the quality specified in the design, or relevant standard specifications and the workmanship is good.
- * The specifications laid down have been followed and the work has been finished neatly.
- * The floor surface is smooth and sloping slightly towards the pan.
- * The foot-rests have been fixed at the proper place and at an angle, as in the drawing.
- * 50 mm wide holes have been provided in the pit lining in alternate layers up to the invert of the pipe or drain, and the lining above is in solid brick work (no holes). If the soil is sandy, or if a sand envelope has been provided, or there are chances of damage by field rats, the width of the holes has been reduced to 12 to 15 mm. If the foundation of the building is close to the pits, holes have not been provided in the portion of lining facing the foundation. In cement concrete ring lining, rings below the invert of pipes or drains should have 50 mm circular holes staggered about 200 mm apart.

- * The covers over the pits, drains, and junction chamber have been placed properly.

- * The pan and trap used are of a design specified for pour flush and these have been fixed properly so as to provide a 20 mm waterseal, and that the joint is water tight and the top of the pan is flush with the latrine floor.

- * No vent pipe has been provided.

- * A well ventilated superstructure has been provided to enable use of the latrine.

- * All surplus materials have been removed and the site cleared and dressed.

- * The users have been educated on the use and maintenance of PF latrines.

Annexes

Annex-1

Pour Flush Latrines with Dry Circular Leach Pits

Size of Pits and Materials Required for Construction (for 5, 10 and 15 users)

Assumptions:

- (a) 2 year desludging interval or solid storage volume (See page 5 under "storage period")
- (b) Solids accumulation rate of 0.04m³/capita/day, assuming water is used for anal cleansing (See page 4 under "sludge accumulation rate")
- (c) Hydraulic loading 9.5 litres/capita/ ~~year~~ 5 litres per day for washing and cleaning squatting pan and latrine floor (See page 5 under "flow to the pit")
- (d) Ground water level throughout the year below the bottom of pit (See page 4 under "sludge accumulation rate")

DRY PITS: SIZE IN MM

Soil type	Infiltration rate (l/m ² /day)	5 Users			10 Users			15 Users		
		Pit Dia	Pit Depth	Width of back filling	Pit Dia	Pit Depth	Width of Back filling	Pit Dia	Pit Depth	Width of back filling
Clay; compact silty loams	10	900	650	750	1000	1050	900	1200	1100	1450
Porous clay loams	20	900	650	100	1000	1050	150	1200	1100	350
Sandy loams	30	900	650	-	1000	1050	-	1200	1100	-
Sand	50	900	650	-	1000	1050	-	1200	1100	-

DRY PITS: MATERIALS REQUIRED FOR CONSTRUCTION

Materials	Unit	Quantity			Materials	Unit	Quantity		
		5 Users	10 Users	15 Users			5 Users	10 Users	15 Users
With Pipes And Bifurcation Chamber				With Covered Brick Drain					
1. Bricks	Nos.	400	720	850	1. Bricks	Nos.	470	790	940
2. Cement	Bags	2.53	3.17	3.97	2. Cement	Bags	2.64	3.28	4.14
3. Sand	Cum	0.43	0.56	0.66	3. Sand	Cum	0.45	0.58	0.69
4. Brick ballast	Cum	0.23	0.23	0.23	4. Brick ballast	Cum	0.21	0.21	0.21
5. Stone ballast	Cum	0.15	0.16	0.22	5. Stone ballast	Cum	0.14	0.15	0.21
6. M.S. bars	Kg	8.00	8.50	12.00	6. M.S. bars	Kg	8.00	8.50	12.00

Note:

1. In soils with low infiltrative capacity, the pit size has been kept the same as in high infiltrative capacity soils, but the infiltration area has been increased by providing backfilling all around the pits (see page 8 under "pits in soils with low infiltrative capacity");
2. Depths of pit given above is the depth of pit below the invert of pipes or drains; the total depth of pits would be 300 mm more to allow free space (see page 4).

Annex-2

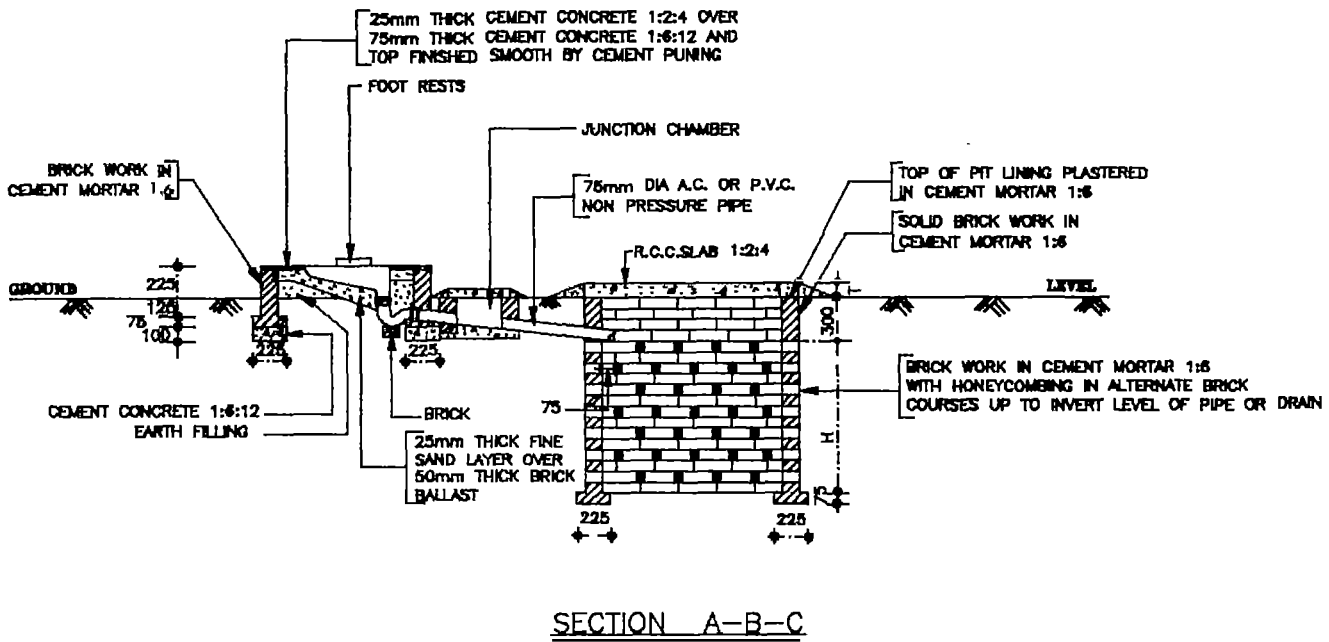

NOTE:-

THE SIZE OF HOLES IN HONEYCOMBING SHOULD BE 50mm WIDE AND FULL HEIGHT OF BRICK COURSE. HOWEVER, IN SANDY SOIL OR WHERE THERE ARE CHANCES OF DAMAGE BY FIELD RATS OR WHERE SAND ENVELOPE IS PROVIDED, WIDTH OF HOLES BE REDUCED TO 12 TO 15mm.

DRY PIT *

USERS	D	H	T
5	900	650	50
10	1000	1050	50
15	1200	1100	60

* FOR TWO YEAR STORAGE VOLUME, LONG TERM INFILTRATION RATE OF SOIL 30 LITERS PER SQ.METER PER DAY, EFFECTIVE SIZE OF FORMATION SOIL 0.2mm OR LESS AND GROUND WATER TABLE BELOW THE PIT BOTTOM

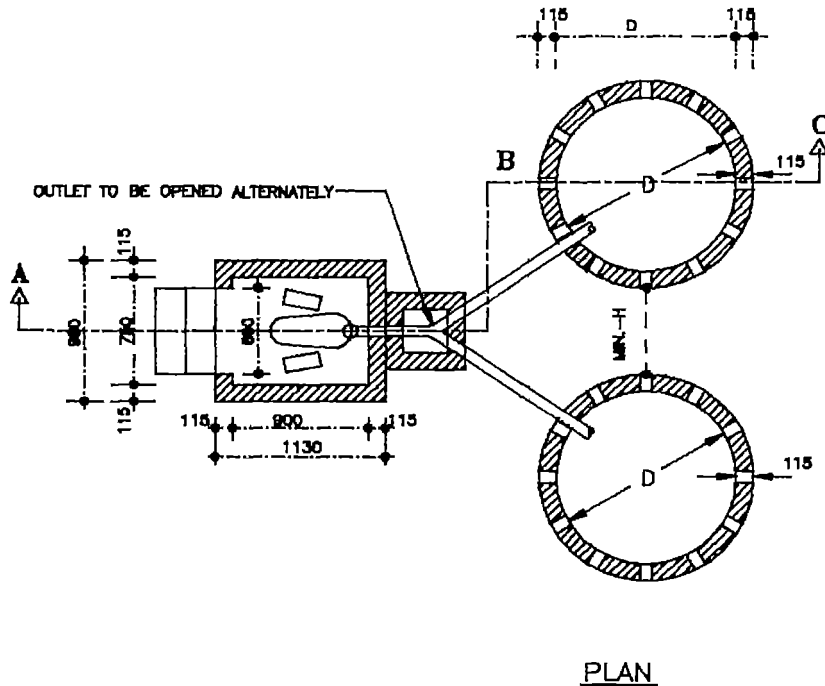

Scale: 1:50

All dimensions in mm

POUR FLUSH LATRINE WITH DRY CIRCULAR PITS

Pour Flush Latrines with Wet Circular Leach Pits

Size of pits and Materials required for construction (for 5, 10 and 15 users)

Assumptions:

- (a) 2 year desludging interval or solid storage volume (see page 5 under "storage period")
- (b) Solids accumulation rate of 0.078m³/capita/day, assuming water is used for anal cleansing (see page 4 under "sludge accumulation rate")
- (c) Hydraulic loading 9.5 litres/capita/ ~~year~~ 5 litres per day for washing and cleaning squatting pan and latrine floor (see page 5 under "flow to the pit")
- (d) Ground water level is above the bottom of pit (see page 4 under "sludge accumulation rate")

WET PITS: SIZE IN MM

Soil type	Infiltration rate (l/m ² /day)	5 Users			10 Users			15 Users		
		Pit Dia	Pit Depth	Width of back filling	Pit Dia	Pit Depth	Width of Back filling	Pit Dia	Pit Depth	Width of back filling
Clay; compact silty loams	10	900	1250	100	1200	1400	450	1400	1550	700
Porous clay loams	20	900	1250	-	1200	1400	-	1400	1550	-
Sandy loams	30	900	1250	-	1200	1400	-	1400	1550	-
Sand	50	900	1250	-	1200	1400	-	1400	1550	-

WET PITS: MATERIALS REQUIRED FOR CONSTRUCTION

Materials	Unit	Quantity			Materials	Unit	Quantity		
		5 Users	10 Users	15 Users			5 Users	10 Users	15 Users
With Pipes And Bifurcation Chamber				With Covered Brick Drain					
1. Bricks	Nos.	740	990	1200	1. Bricks	Nos.	810	1080	1300
2. Cement	Bags	3.08	4.32	5.62	2. Cement	Bags	3.19	4.49	5.82
3. Sand	Cum	0.57	0.75	0.91	3. Sand	Cum	0.59	0.78	0.94
4. Brick ballast	Cum	0.23	0.23	0.23	4. Brick ballast	Cum	0.21	0.21	0.21
5. Stone ballast	Cum	0.15	0.22	0.32	5. Stone ballast	Cum	0.14	0.21	0.31
6. M.S. bars	Kg	8.00	12.00	15.00	6. M.S. bars	Kg	8.00	12.00	15.00

Note:

1. In soils with low infiltrative capacity, the pit size has been kept the same as in high infiltrative capacity soils, but the infiltration area has been increased by providing backfilling all around the pits (see page 8 under "pits in soils with low infiltrative capacity");
2. Depths of pit given above is the depth of pit below the invert of pipes or drains; the total depth of pits would be 300 mm more to allow free space (see page 4).

Annex-4

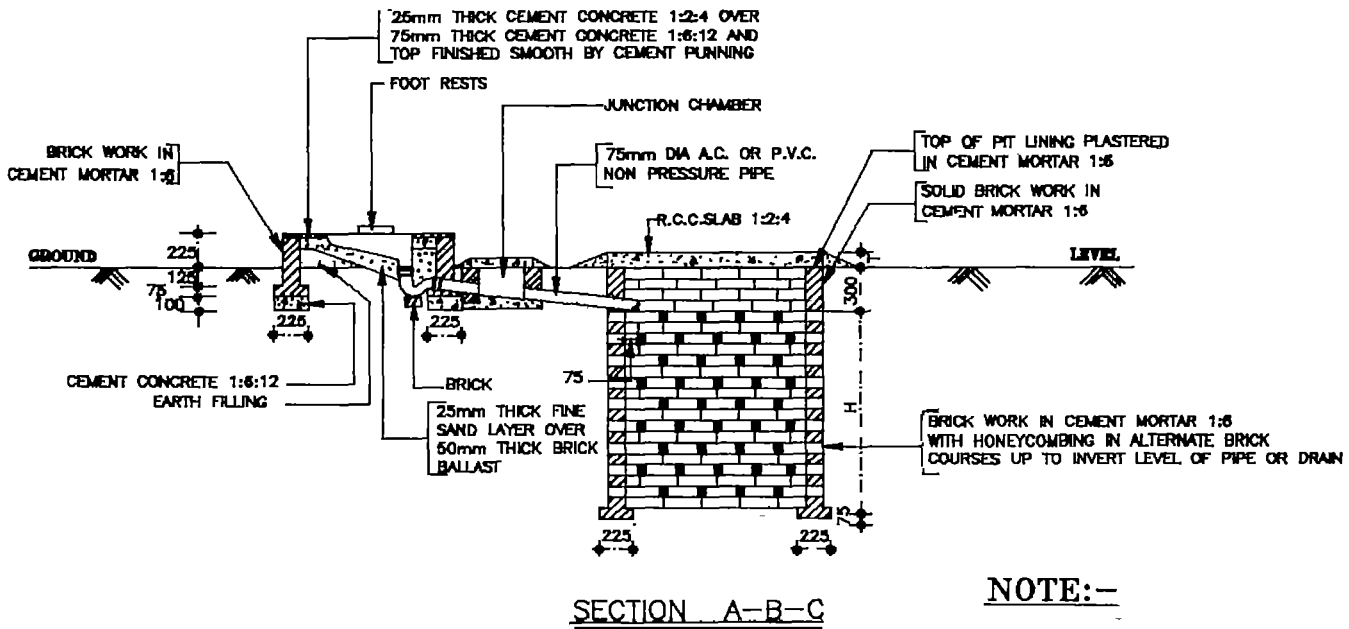

NOTE:-

THE SIZE OF HOLES IN HONEYCOMBING SHOULD BE 50mm WIDE AND FULL HEIGHT OF BRICK COURSE. HOWEVER, IN SANDY SOIL OR WHERE THERE ARE CHANCES OF DAMAGE BY FIELD RATS OR WHERE SAND ENVELOPE IS PROVIDED, WIDTH OF HOLES BE REDUCED TO 12 TO 15mm.

WET PIT *

USERS	D	H	T
5	900	1250	50
10	1200	1400	60
15	1400	1550	75

* FOR TWO YEAR STORAGE VOLUME, LONG TERM INFILTRATION RATE OF SOIL 30 LITERS PER SQ.METER PER DAY, EFFECTIVE SIZE OF FORMATION SOIL 0.2mm OR LESS AND GROUND WATER TABLE ABOVE THE PIT BOTTOM

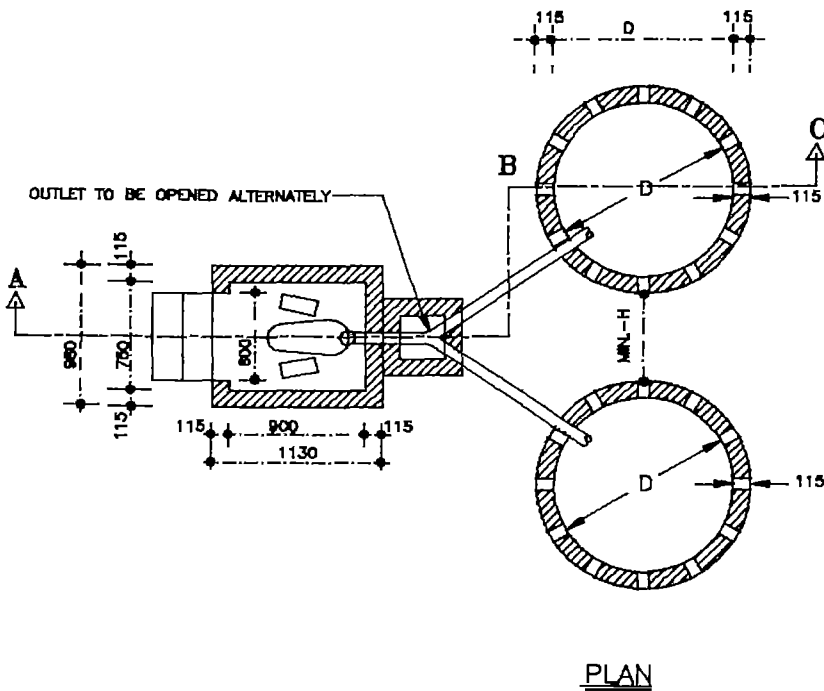

Scale: 1:50

All dimensions in mm

POUR FLUSH LATRINE WITH WET CIRCULAR PITS

Bill of Quantities for Pour Flush Latrine with Dry and Wet Circular Leach Pits

Assumptions: The design shown in drawings on pages 25 and 27; soil of effective size 0.2 mm or less, long term infiltration rate of soil 30 litres per m² per day and 2 year desludging interval.

S.No.	Item	Unit	Dry twin circular leach pits Quantities:			Wet twin circular leach pits Quantities:		
			5 Users	10 Users	15 Users	5 Users	10 Users	15 Users
FOUNDATION AND PLINTH								
1.	Earthwork in excavation including disposal of excavated earth lead up to 50m and lift up to 1.5m, disposed earth to be levelled and neatly dressed.	Cum	0.25	0.25	0.25	0.25	0.25	0.25
2.	Providing and laying cement concrete in foundation, excluding the cost of centring and shuttering 1:6:12 (1 cement:6 fine sand:12 brick ballast 40 mm nominal size).	Cum	0.08	0.08	0.08	0.08	0.08	0.08
3.	Brickwork with bricks of class designation 75 in foundation and plinth in cement mortar 1:6 (1 cement : 6 fine sand).	Cum	0.21	0.21	0.21	0.21	0.21	0.21
4.	25 mm thick with 12.5 mm nominal size stone aggregate cement concrete flooring 1:2:4 (1 cement:2 coarse sand:4 graded stone aggregate) finished with a floating coat of neat cement including cement slurry, rounding of edges and strips etc. over 75 mm thick with 40 mm nominal size brick ballast cement concrete 1:6:12 (1 cement:6 fine sand:12 brick ballast).	Sqm	0.68	0.68	0.68	0.68	0.68	0.68
5.	Supplying and fixing squatting pan, trap and footrests.	Set	1	1	1	1	1	1

S.No.	Item	Unit	Dry twin circular leach pits			Wet twin circular leach pits		
			Quantities:			Quantities:		
			5 Users	10 Users	15 Users	5 Users	10 Users	15 Users
INTERCONNECTION BETWEEN PITS AND TRAP								
ALTERNATIVE - 1								
Pipes With Bifurcation Chamber								
1.	Earthwork in excavation including disposal of excavated earth lead upto 50 m and lift upto 1.5 m, disposed earth to be levelled and neatly dressed.	Cum	0.40	0.40	0.45	0.40	0.45	0.51
2.	Supply, lay and joint 75mm dia. A.C. pipe including jointing material etc. complete.	M	3.0	3.0	3.5	3.0	3.5	4.0
3.	Providing and laying cement concrete in foundation and plinth excluding the cost of centring and shuttering 1:6:12 (1 cement: 6 fine sand:12 brick ballast 40 mm nominal size).	Cum	0.02	0.02	0.02	0.02	0.02	0.02
4.	Brickwork with bricks of class designation 75 in foundation and plinth in cement mortar 1:6 (1 cement:6 fine sand).	Cum	0.03	0.03	0.03	0.03	0.03	0.03
5.	12 mm cement plaster of mix 1:4 (1 cement:4 coarse sand) finished with cement punning.	Sqm	0.15	0.15	0.15	0.15	0.15	0.15
6.	Providing and laying cement concrete 1:2:4(1 cement:2 coarse sand: 4 stone ballast 20 mm nominal size) in drains and benching, excluding the cost of centring & shuttering but including rendering the surface smooth with cement.	Cum	0.002	0.002	0.002	0.002	0.002	0.002

S.No.	Item	Unit	Dry twin circular leach pits			Wet twin circular leach pits		
			Quantities:			Quantities:		
			5 Users	10 Users	15 Users	5 Users	10 Users	15 Users
7.	Reinforced cement concrete work 1:2:4 (1 cement:2 coarse sand:4 graded stone aggregate 20 mm nominal size) excluding cost of centring, shuttering and reinforcement.	Cum	0.005	0.005	0.005	0.005	0.005	0.005
8.	Reinforcement for R.C.C. work including bending, blinding and placing in position complete.	Kg	0.60	0.60	0.60	0.60	0.60	0.60
ALTERNATIVE - 2								
Covered Brick Drains								
(3 m for 5 & 10 users and 3.5 m for 15 users of dry pits and 3 m for 5 users, 3.5 m for 10 users and 4 m for 15 users of wet pits)								
1.	Earthwork in excavation including disposal of excavated earth lead upto 50 m and lift upto 1.5 m, disposed earth to be levelled and neatly dressed.	Cum	0.20	0.20	0.23	0.20	0.23	0.26
2.	Brickwork with bricks of class designation 75 in foundation and plinth in cement mortar 1:6 (1 cement:6 fine sand).	Cum	0.12	0.12	0.14	0.12	0.14	0.16
3.	Brickwork with bricks of class designation 75 in foundation and plinth in mud mortar or cement mortar 1:12.	Cum	0.06	0.06	0.07	0.06	0.07	0.08
4.	Providing and laying cement concrete 1:3:6 (1 cement:3 coarse sand:6 graded stone aggregate 20mm nominal size) in haunches of drain excluding the cost of centring and shuttering.	Cum	0.003	0.003	0.004	0.003	0.004	0.004

S.No.	Item	Unit	Dry twin circular leach pits			Wet twin circular leach pits		
			Quantities:			Quantities:		
			5 Users	10 Users	15 Users	5 Users	10 Users	15 Users
5.	12 mm cement plaster of mix 1:4 (1 cement:4 coarse sand) finished with cement punning.	Sqm	0.86	0.86	1.00	0.86	1.00	1.14
6.	Making bed of drain of 'U' cross sectional shape as per drawing and finished smooth with cement punning.		Job	Job	Job	Job	Job	Job
LEACH PITS								
1.	Earth work in excavation including disposal of excavated earth lead upto 50 m, disposed earth to be levelled and neatly dressed.							
	Upto 1.5 m below ground level	Cum	2.40	3.93	5.35	3.62	5.59	7.13
	1.5 m to 3.0 m below ground level	Cum	-	-	-	0.23	0.89	1.83
2.	Brickwork with bricks of class designation 75 in foundation and plinth in cement mortar 1:6 (1 cement:6 fine sand).	Cum	0.33	0.36	0.43	0.33	0.43	0.49
3.	Honeycomb brick work 10/11.4 cm thick with bricks of class designation 75 in cement mortar 1:6 (1 cement:6 fine sand).	Cum	0.48	0.85	1.05	0.92	1.33	1.70
4.	12 mm cement plaster of mix 1:6 (1 cement:6 fine sand) over the top of pit lining.	Sqm	0.73	0.81	0.95	0.73	0.95	1.09

S.No.	Item	Unit	Dry twin circular leach pits			Wet twin circular leach pits		
			Quantities:			Quantities:		
			5 Users	10 Users	15 Users	5 Users	10 Users	15 Users
5.	Reinforced cement concrete work 1:2:4 (1 cement:2 coarse sand:4 graded stone aggregate 20 mm nominal size) excluding cost of centring, shuttering and reinforcement.	Cum	0.10	0.12	0.19	0.10	0.19	0.31
6.	Reinforcement for R.C.C. work including bending, binding and placing in position complete.	Kg	7.0	7.8	11.5	7.0	11.5	14.5



