

Prof. G.J. Alaerts
S. Veenstra
M. Bertvelsen
L.A. van Duijf

IHE Report Series 20

3 4 1.5

9 0 F E

Feasibility of Anaerobic Sewage Treatment in Sanitation Strategies in Developing Countries



HASKONING
Royal Dutch Consulting
Engineers and Architects

IHE ■
D E L F T

International Institute for
Hydraulic and Environmental
Engineering

Wageningen Agricultural University

341.5-90FE-7797

Feasibility of Anaerobic Sewage
Treatment in Sanitation Strategies in
Developing Countries

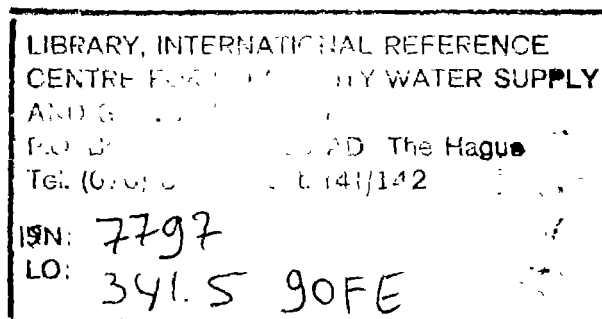

**Feasibility of Anaerobic Sewage
Treatment in Sanitation Strategies in
Developing Countries**

LIBRARY
INTERNATIONAL REFERENCE CENTRE
FOR COMMUNITY WATER SUPPLY AND
(IRC)

Acknowledgment

This report was written and edited by

Prof. G.J. Alaerts
Mr. S. Veenstra
Mr. M. Bentvelsen
Mr. L.A. van Duijl

(International Institute for Hydraulic
and Environmental Engineering - Delft)

with contributions from

Mr. M. Lindfield
Mr H. Specker

(Netherlands Economic Institute - Rotterdam)

Mr. L. van Velsen
Mr. L. Wildschut

(Haskoning Consulting Engineers - Nijmegen)

Prof. G. Lettinga
Dr. L. Hulshoff Pol
Ms. M. Zuidema

(Agricultural University Wageningen - Wageningen)

For further inquiries and to order additional copies.

International Institute for
Hydraulic and Environmental
Engineering

P.O. Box 3015
2601 DA Delft
The Netherlands
Phone +31 - 15 - 78 80 21,
Fax +31 - 15 - 12 29 21,
Telex 38099 ihe nl

Executive Summary

Background and scope

1. Sanitation is equally important as the provision of safe drinking water to improve public health. Moreover adequate disposal of liquid waste flows reduces environmental pollution and thereby contributes to the well-being of the people. During the past decade insufficient attention was paid to sanitation in tropical developing and newly industrialising countries, this has often resulted in limited public health benefits from investments made in water supply schemes.

Rapid urbanisation in most of these countries led to sometimes very high population densities, putting the "accommodation capacity" of the surrounding environment under stress and endangering public health. This emphasizes the need for appropriate and new sanitation approaches to the specific conditions in urban and peri-urban areas.

(Chapters 1 and 2).

2. The Section Research and Technology (DPO/OT) of the Dutch Directorate-General for International Cooperation (DGIS) has in the past 10 years supported several projects (in Colombia, Indonesia and India) aiming at demonstrating the feasibility of and at the optimization of anaerobic reactors for treatment of domestic waste water. Anaerobic waste water treatment is already applied on numerous (some 200-300) industrial waste waters. Other documented research on its application on domestic waste water, notably in Brazil, India and P.R. China, confirms interesting potentials. Therefore the International Institute for Hydraulic and Environmental Engineering (IHE), Delft, The Netherlands, was requested by DGIS to assess the feasibility of anaerobic sewage treatment for tropical developing countries.

3. This study considers anaerobic treatment technology from different points of view

– as a **treatment technology**, which means that the study focusses on treatment efficiency and efficacy, and compares these with conventional (usually aerobic) alternatives;

– as a technology which may in addition affect favourably the design criteria of the sewage collection network; in other words, the new boundary conditions (in terms of optimal scale of operation, management

of settleable material, etc.) set by this technology may lead to the development of a new **comprehensive sanitation programme** affecting notably sewerage design and institutional management aspects which would favour programmes with treatment at intermediate scale;

– as a technology with different merits and drawbacks in function of its possible role in the main **sanitation strategies** (with public health, environmental health, and re-use objectives).

(Chapters 1 and 2).

4. This study reviews as much as possible available documented experience on different anaerobic reactor types. Because up to now most larger-scale pilot experimenting has been carried out with the so-called Up-flow Anaerobic Sludge Blanket (UASB) reactor, this reactor type receives most attention. Some of the conclusions however pertain equally well to other reactor types.

Though it is acknowledged that anaerobic ponds can be considered anaerobic reactors as well, here high-rate reactors with low land requirements and higher efficiencies are emphasized.

The technology is reviewed for its appropriateness and relevance in low cost programmes. Special attention was therefore given to its technical, economic, financial and institutional aspects.

(Chapters 2 and 3).

5. In first instance the assessment, and this report, are organised following the unit scale at which sanitation is implemented (i) on-site sanitation, (ii) sewage collection with off-site or centralised treatment, and (iii) intermediate-scale programmes. Intermediate means treatment units serving a small to an intermediate number of households (some tens to some hundreds) ("communal treatment"), or a combined sanitation programme in which part of the waste is treated on-site (one treatment shared by a number of households) and the resulting, partially treated flow, is further transported and polished in a second treatment step off-site.

Contrary to alternative treatment technologies, anaerobic treatment appears to offer, at least in principle, the unique opportunity of application at all these three levels.

Which treatment technology is most feasible for a

given case is determined by a number of situational determinants, and the objectives of a particular sanitation strategy (public health, different degrees of environment protection, shallow ground water protection, re-use) A landscape- and selection matrix can be developed, allowing to indicate the conditions under which anaerobic treatment is the most appropriate option.

(Chapter 7).

Application in on-site sanitation

6. On-site sanitation should provide for disposal of toilet (black) waste water as well as of (kitchen and bathroom) sullage. Black waste water is characterized by low flow, high strength (in terms of BOD and COD) and high pathogen content. Sullage is higher in volume but contains lower BOD and COD concentration (yet its pollution load is of equal importance)

The benefit of anaerobic treatment technology relates to better degradation of BOD and COD and hence better quality of the reactor effluent as compared to alternative treatment (septic tank or leaching pits). However, for many situations effluent quality is irrelevant as effluent (black waste water) is percolated (leached) into the soil. *If leaching can be applied, that is if population density is not excessively elevated, the simple leaching options serving one or a few households are commonly cheaper than any anaerobic option.* In these cases sullage is generally drained away over the surface (gutters, drains).

The major and additional consideration to opt for leaching is a public health strategy to keep pathogens in the underground where they slowly die off (Chapter 4).

7. Against the above cheapest option plead the shallow ground water protection (for drinking purposes) and the environmental strategies. In an environmental strategy it must be recognized that sullage represents considerable pollution and should, if financially possible, be treated before discharge into a receiving river. Also, it is still insufficiently acknowledged that the leaching bed of cheap on-site systems easily clogs leading its owner to short-circuit the effluent to the surface drain or sewer. Though exact figures are not available, this may be both in developing and industrialised countries the rule rather than the exception. This adds to the pollution load in drains and sewers.

If an environmental strategy is selected (above a public health strategy) the quality of effluent to be drained away becomes of higher concern and anaerobic treatment may become relevant. Because the waste water must be drained, sewerage design criteria will

determine the spatial serving area of a reactor. Some tens of households ("shared") or hundreds of households ("communal") can be connected to one treatment unit, whose effluent needs to be further transported. This effluent however will not contain much settleable solids and is to be considered partially treated (but to a higher degree than with alternative systems).

This option is more expensive. The reactor can accept mixed (grey) waste water or only black waste water.

(Chapter 4)

8. The same considerations pertain to public facilities (a toilet/bathing facility for a number of households).

9. The operation and maintenance (caretaking) of an individual anaerobic reactor is comparable to that of septic tanks and leaching pits, and faces therefore the same difficulties (poor maintenance and desludging).

A reactor which is shared or is communal offers the advantages that (i) a caretaker can be paid by the connected households, and can then be held accountable, that (ii) caretakers are a smaller and more "professional" group to be approached by local government for e.g. training purposes, than individual households, and that (iii) such reactors can be located strategically to allow for easier access (and lower cost) by desludging carts.

(Chapter 4).

Application at intermediate level

10. Intermediate-scale means collection of (usually) grey waste water in shallow or small-bore sewers followed by local (pre-)treatment. The effluent is then transported outside the city in a cheap sewer or drain as most settleable solids have been removed. Off-site post-treatment, possibly in stabilization ponds on cheap land, is a useful and feasible option.

In densely populated, unplanned residential areas shallow or small-bore sewers become more cost-effective than on-site sanitation.

(Chapter 6).

11. The local treatment can probably best be achieved by **communal anaerobic reactors**, to which some hundreds of households are connected. Anaerobic reactors of the UASB type have shown to operate well and reliably at such scale, yielding reasonable treatment efficiency on BOD and COD (60-80%). As pathogen removal is as poor as with alternative treatment options (with the exception of 20-25 day retention ponds), the effluent of the local treatment needs to

be managed with care. *Communal treatment could prove an optimal scale from the institutional point of view, involving community paid caretakers, that because of their small number can be trained and monitored by the responsible government, sludge is easier to be removed*

Experience with such schemes is still limited. *The technical feasibility of intermediate scale UASB reactors poses probably no problems, but its financial and institutional feasibility remains to be demonstrated (Chapter 6).*

Application in off-site, centralised treatment

12. Assessment focussed on anaerobic treatment as a treatment technology, it is compared with (land-extensive) ponding, and high-rate aerobic treatment as alternative options. Performance parameters compared are: (i) removal efficiencies for BOD, COD, Kjeldahl-nitrogen, Suspended Solids and pathogens, (ii) treatment efficacy, reflecting process stability, reliability and sturdiness, and (iii) sludge production rates and handling requirements. In addition economic comparison is carried out using Net Present Values, including land costs.

Documented experience on pilot and demonstration plant scale exists for 5 relevant cases (Colombia, India, Brazil) which is reviewed here. (Chapter 5).

13. *Anaerobic treatment (as UASB) has shown to be economically attractive as compared with all alternative treatment options. This pertains to full treatment yielding a given, common effluent quality of BOD = 20 mg/L, it implies provision of post-treatment after the anaerobic reactor. However, if land cost is low (say below US\$ 4-8 - which can be found only relatively far away from the city) ponds may become more competitive. This statement pertains to countries with warm sewage during all or most of the year (above 20 °C), in countries with colder sewage during winter season current anaerobic treatment technology is not yet economically feasible.*

Day-average hydraulic retention time (in warm climate) for UASB is 6-8 h. For short periods this may be lowered to 4 h. Load shocks can be well accommodated, as can hydraulic fluctuations within certain limitations. Pronounced hydraulic shocks can disturb the process (sludge wash-out). Start-up procedure is relatively simple and takes less than 2 months. In general, pilot plants have proven to operate over long periods (1 year) steadily and reliably on municipal waste water (Chapter 3 and 5)

14. Anaerobic treatment is favoured by high sewage temperatures, high(er) sewage strength, restricted dilution (by rain) and limited hydraulic shock loads in the reactor. This pleads for treating only dry-weather flow discharge in the UASB reactor.

The reactor requires little energy, rendering it also more autonomous and independent of power failures. It needs little mechanical equipment and thus less specialized maintenance personnel. Area requirements are significantly lower, even taking into account post-treatment and sludge drying beds. Also sludge production rates and dewaterability and manageability of sludge are significantly more favourable than with other (aerobic) high-rate treatment technologies. (Chapter 5).

15. The process can be operated and routine maintenance (notably sludge removal and drying; destruction of foam layer in gas collector; de-clogging of inlet system) carried out by a small number of caretakers and (less-skilled) operators. For start-up, regular (weekly) monitoring and problem shooting, assistance of qualified process engineers is necessary. (Chapter 5)

16. Disadvantage of anaerobic treatment as compared to all alternatives is incomplete removal of BOD and COD (removal efficiency on BOD at this scale 65-80%, against 80-95% for alternatives), and very low removal of organic, oxidizable Kjeldahl-nitrogen (NOD). *This renders necessary post-treatment like cascade aeration, trickling filter, pond (short retention of typically 1-5 days) or activated sludge*

As is the case with all alternatives, except long retention ponds, bacteria and virus removal is insufficient (removal efficiency of 2 log-units). Helminth ova are better removed than in all alternatives, except ponds (90-99.9%). Only long retention ponds with 20-25 days retention can adequately remove all pathogens (Chapter 5)

17. *Anaerobic treatment, being an excellent and relatively cheap pre-treatment on BOD, Settleable Solids and (to some extent) helminth ova, offers good perspectives as part of effluent recovery or recycling schemes for agriculture (sewage irrigation), pisciculture and aquaculture*

Sludges are well stabilized, easy to handle and a good soil conditioner rich in nutrients

Biogas recovery can be economically justified if a large constant gas user in the neighbourhood is willing to buy it, or, at larger scale (say for plants treating sewage of at least 20,000 cap) by converting it into

electricity. Safety measures must be strict however.
(*Chapter 5*).

18. The systematic introduction of waste water collection and treatment in general, and the introduction of a new technology like anaerobic treatment in particular, necessitate adequate organisation of the water supply and sanitation sector institutions to ensure good planning, implementation and operation of the infrastructure. The introduction of new technology addresses specific demands to the professional and educational institutions

Similarly, sound design and operation can only be carried out by well-trained and experienced staff
(*Chapter 5*).

Contents

1	Introduction	1
1.1	Background of the study	1
1.2	Procedure and organisation of the study	1
1.2.1	Terminology	1
1.2.2	Procedure of the study	2
1.2.3	Organisation of the study	3
1.3	Waste water management in developing countries	3
1.3.1	Sanitation and public health	3
1.3.2	Urban and rural stress on the environment	4
1.4	Waste water treatment technologies	5
1.4.1	Waste water and its treatment	5
1.4.2	Waste water treatment	6
2	Strategies and Determinants of Sanitation	11
2.1	Introduction	11
2.2	Available technologies for human waste disposal	11
2.2.1	On-site sanitation systems	11
2.2.2	Waterborne sewerage	12
2.3	Determinants of sanitation programmes	14
2.4	Site conditions	14
2.4.1	General overview	14
2.4.2	Physical environment	14
2.4.3	Urbanisation pattern	15
2.4.4	Existing service levels	15
2.5	Environmental feasibility	17
2.5.1	Surface water protection	17
2.5.2	Ground water protection	18
2.5.3	Other environmental concerns	18
2.6	Institutional development, community involvement and socio-cultural aspects	19
2.6.1	Institutional development	19
2.6.2	Community involvement	19
2.6.3	Socio-cultural factors	20
2.7	Financial and economic aspects	21
2.7.1	Overview	21
2.7.2	Financial analysis	21
2.7.3	Economic analysis	21
2.8	A preliminary "landscape matrix" with strategies and determinants	22
3	Anaerobic Treatment of Domestic Waste Water	23
3.1	Introduction	23
3.2	Anaerobic microbiology	23
3.3	Anaerobic reactor types	24
3.3.1	Low-rate applications	24
3.3.2	High-rate applications	24
3.4	Principles of anaerobic sewage treatment processes	26
3.4.1	General	26

3.4.2	Removal of oxygen consuming substances	27
3.4.3	Removal of nutrients. Kjeldahl-nitrogen	28
3.4.4	Removal of suspended solids	28
3.4.5	Removal of pathogens	28
3.5	Performance of UASB reactors	29
3.5.1	UASB as on-site treatment system	29
3.5.2	UASB as off-site treatment system. the Cali pilot plant research	31
3.5.3	UASB as off-site treatment system: Bucaramanga	32
3.5.4	UASB as off-site treatment: Kanpur	32
3.6	Major conclusions and recommendations	33
	Pictures	37
4	Anaerobic Waste Water Treatment at On-site Scale	41
4.1	Introduction	41
4.2	Approach of the study	41
4.2.1	Treatment	41
4.2.2	Effluent disposal	42
4.2.3	Scale of the facility	42
4.2.4	Developing a case study	42
4.3	On-site sanitation simulation study (case of the Indonesian kampung)	43
4.3.1	General approach	43
4.3.2	Technical description	47
4.3.3	Results	48
4.3.4	Financial and institutional aspects	53
4.4	Cost-efficiency assessment of the treatment	53
4.4.1	Oxygen consuming substances	54
4.4.2	Pathogens	54
4.5	Conclusions	54
5	Anaerobic Waste Water Treatment at Off-site Scale	59
5.1	Introduction	59
5.1.1	The sewage treatment	59
5.1.2	The sewage collection	59
5.2	Criteria for selecting off-site treatment reactor types	59
5.3	Environmental feasibility	60
5.3.1	Oxygen consuming substances. BOD ⁵ and COD	61
5.3.2	Kjeldahl-nitrogen	64
5.3.3	Suspended solids	65
5.3.4	Pathogens	65
5.3.5	Sludge production and handling	67
5.3.6	Odours and gases	69
5.4	Reliability	69
5.4.1	Hydraulic variations	69
5.4.2	Variation in sewage composition	70
5.5	Institutional and technical manageability	70
5.5.1	The political factor	70
5.5.2	The managerial factor	71
5.5.3	The societal factor	71
5.5.4	The scientific support factor	71
5.5.5	The technical standards factor	72
5.5.6	Management aspects	72
5.6	Economic and financial considerations	73
5.6.1	Costing procedures	73

5.6.2	Relevant cost components	74
5.6.3	Costs specific for anaerobic treatment technologies	74
5.6.4	Comparison of costs for treatment alternatives	75
5.7	Biogas: a realistic perspective?	82
6	The position of Anaerobic Treatment in Waste Water Management Schemes	85
6.1	Post-treatment options	85
6.1.1	Needs and opportunities	85
6.1.2	Simple aeration	85
6.1.3	Biological post-treatment, activated sludge, oxidation ditch	85
6.1.4	Biological post-treatment, trickling filter	86
6.1.5	Ponds	87
6.1.6	Other options	87
6.2	Anaerobic reactors in waste water management schemes	87
6.2.1	Centralised off-site option, Common sewerage	87
6.2.2	Decentralised off-site option	87
6.2.3	Centralised treatment, sewage conveyed in drains + sewer	89
6.2.4	Centralised treatment, sewage conveyed in drains	90
6.2.5	Anaerobic treatment in waste water re-use schemes	90
7	Summary and Conclusions	93
7.1	Background	93
7.2	Determinants for sanitation programme planning	93
7.3	Feasibility of anaerobic systems at on-site level	94
7.4	Feasibility of anaerobic systems at intermediate scale	95
7.5	Technical feasibility of anaerobic systems at off-site level	95
7.6	Potential use in resource recovery schemes	97
7.7	Economic/financial analysis	97
7.8	The landscape-matrix	98
7.9	Needs for further research	98
Appendix 1	Waste Water Treatment Technologies	101
Appendix 2	Economic and Financial Assessment of Sanitation Projects: An Overview	107
Glossary		119
Literature		123

Preface

The Section of Research and Technology (DPO/OT) of the Dutch Directorate-General for International Cooperation (DGIS) has a long-standing interest in the research and development of domestic waste water treatment technologies. It pioneered in promoting the development of anaerobic treatment processes as appropriate technology for tropical, developing countries. The Section has since 1982 supported projects notably in Colombia and Indonesia, which were carried out, at the Dutch side, by the National Institute for Public Health and Environmental Hygiene (RIVM), and Haskoning Consulting Engineers, with the scientific support from the Agricultural University Wageningen (AUW).

In February 1989 the Section commissioned the International Institute for Hydraulic and Environmental Engineering (IHE), Delft, to assess the feasibility of anaerobic high-rate treatment (in special reactors) of domestic sewage in tropical developing countries, the study was carried out in collaboration with the Netherlands Economic Institute, Haskoning Consulting Engineers and the Agricultural University Wageningen. This desk study should support the Section in policy development with regard to sanitation related research¹.

The feasibility of a specific treatment process is dictated by the sanitation strategy and programme in which it is expected to fit (like *e.g.* in a sewerage or an on-site disposal programme, in a re-use strategy, etc.). A variety of possible sanitation strategies and programmes can be applied in the developing countries, and this number is larger than for industrialised countries because the developing world is more heterogeneous and changes fast. The technical and financial feasibilities of such strategies and programmes depend on their turn on the opportunities which new and better performing treatment processes create. Anaerobic treatment of domestic sewage has already shown it could possibly fit several of these strategies and programmes. Therefore, three master questions were to be answered.

- which possible sanitation strategies and programmes are or can become realistic?
- does a high-rate anaerobic treatment process fit in or promote these programmes?
- if so, does it offer a competitive advantage when compared to all the available alternatives? Feasibility must be defined in terms of technical, economic, financial and institutional determinants.

This approach attempts thus to be comprehensive, which made it necessary first to widen the study's scope to describe the sanitation "landscape", and then to focus on the specific position of the isolated anaerobic processes in it as compared to the position of other treatment processes.

This report is written in such a way that one need not be a specialist in the field of sanitation or on anaerobic treatment to follow the "red thread" of the analysis and understand the conclusions.

The study evaluates and reviews the most actual information on the issue, incorporating all available pilot- and demonstration plant performance data. It is however decidedly not intended to be a design manual; for any such purpose the reader should consult the experienced designers/manufacturers, like the consultants Haskoning and DHV International in The Netherlands.

It is envisaged that the results of this analysis will enable policy makers and technicians to become better acquainted with both the merits and the limitations of anaerobic treatment of domestic sewage. It is hoped that this study may also be a

contribution to a better understanding of the complex sanitation problem in the less industrialised countries in the world.

The authors express their sincere thanks to the DGIS Section DPO/OT, and to all who have contributed to this work. They are indebted to reviewers of the draft version, in particular Dr. J.A. Heidman (U.S. EPA, Cincinnati, USA), Prof. M. Switzenbaum (Univ. Massachusetts, Amherst, USA), Prof. W. Verstraete (State Univ. Ghent, Belgium), Mr. W. van Starckenburg (Nat. Institute for Waste Water Treatment, Lelystad, The Netherlands), Mr. E.H. Hofkes (Euroconsult, Arnhem, The Netherlands), Dr. P.M. Modak (Indian Institute of Technology, Bombay, India), Mrs. S.M. Manso Vieira (CETESB, Sao Paulo, Brazil), Prof. van der Graaf (Delft University of Technology, Delft, The Netherlands), Dr. E. Ferguson (TNO, Eindhoven, The Netherlands), Prof. W.J. Jewell (Cornell University, Ithaca, USA), and Prof. F. Fdz-Polanco (Univ. Valladolid, Spain).

The authors would appreciate receiving comments from readers, in order to further strengthen the relevance of the report.

¹ The desk study will be a part of the position paper "Treatment of Liquid Waste in Developing Countries", which is currently under preparation for the Section DPO/OT. This paper will identify the actual position of knowledge and experience with regard to the broad issue of sanitation in developing countries, it will inventorize current research activities and will provide orientations for future research.

1 Introduction

1.1 Background of the study

Provision of safe water in sufficient quantity and the removal of waste water in an hygienic manner (sanitation) are prerequisites for public health, economic development and welfare in any society.

On a global scale, the provision of sanitation in less industrialised countries has a severe backlog when compared to the supply of clean water to the households. The International Drinking Water Supply and Sanitation Decade (IDWSSD, 1981-1990) did emphasize water supply. As a consequence, public health did not improve as much as expected, as adequate disposal of increasing waste water flows was lacking. In the less industrialised, or developing, countries urban sanitation remains characterized by low coverage (10 to 50%). In particular the smaller cities and towns and the peri-urban regions (urban fringes) require special attention given their present low service coverage, their lack of financial and institutional capacities, and their strong growth dynamics. The high urbanisation rates in most developing countries stresses the need for sanitation, as there is a clear relationship between lack of adequate sanitation and poor public health.

The challenge to improve this situation can be translated into assignments to search for technologies that are more effective in removing, transporting and treating the domestic waste, at a lower cost. In addition, new concepts and tools need to be developed that address the urban sanitation problems in more cost-effective ways.

Recent experience with domestic waste water treatment in high-rate anaerobic reactors indicates that this technology has the potential of becoming such an appropriate tool. The anaerobic processes feature short retention times, resulting in cost reduction. The process is promoted by high temperatures, found in countries with a predominantly tropical climate (water temperature above 20 °C). It has been tried out, with success, on pilot scale both as on-site treatment for an individual household, as well as on the scale of typical large sewage treatment works designed to treat the waste water of a whole city

The Section of Research and Technology of the Direction of Private Activities, Education and Research Programmes (DPO/OT) of the Dutch Directorate-General for Development Cooperation (DGIS)

has since 1982 supported activities to study and develop anaerobic sewage treatment technology in developing countries. Two major field research projects were conducted in Colombia and Indonesia

The present study was commissioned to analyse the sub-sector of urban sanitation, to identify the dynamics of its expected development, and to assess the feasibility of anaerobic sewage treatment under various conditions prevailing in less industrialised countries. The study aims, by synthesizing the results and experiences obtained so far, at assessing the technical, economic, financial, and institutional feasibility of anaerobic scenarios in urban areas, as compared to other scenarios. The conclusions and recommendations should assist DGIS (DPO/OT) to further develop its policy with respect to urban sanitation in developing countries and the potentials of anaerobic waste water treatment. The findings of the desk study are to be incorporated in a position paper "Treatment of Liquid Waste in Developing Countries" for the same Section DPO/OT which will give directives for current and future research activities within the field of sanitation and liquid waste disposal in developing countries.

1.2 Procedure and organisation of the study

1.2.1 Terminology

In this study the following concepts are defined and discussed

- "developing countries" will be considered synonymous with "less industrialised countries," comprising the Least Developed Countries (LDCs) as well as the Newly Industrialising Countries (NICs),
- "sanitation" is understood as "integral waste water management," safe and reliable with regard to aspects of public health as well as of the environment. This involves the **removal** of the sewage from the inhabited areas, its **transportation, treatment** and a justifiable **discharge** into a receiving surface or ground water. Included is the disposal of sludge, produced in any part of the treatment. For this study only **domestic** waste water is considered,
- a "sanitation strategy" relates to the objective(s) a government wants to achieve by implementing sanitation programmes,
- a "sanitation programme" is composed of the hard-

ware and software necessary for the appropriate level of waste water management, in order to meet the strategy's objectives; several programmes may fit a strategy;

- "treatment" is a part of this sanitation programme,
- "high-rate" treatment refers to the new generation of waste water treatment reactors, with an optimized design based on a better process-technological understanding.

The basic approach in this study is to discuss first the issues and priorities in the urban sanitation strategies and programmes. Primary decision-making focusses on whether waste treatment and disposal is to be implemented on-site at household scale, off-site at the large scale of a city or town, or at an intermediate scale (township, city quarter). As said earlier, based on pilot scale experience anaerobic treatment could possibly be applied in all three cases.

An **on-site option** conventionally combines collection and treatment, excreta and waste water (black or grey – see *Section 1.4.1*) are disposed at the place of origin, usually by means of percolation of the liquid fraction into the soil, and periodic removal of the collected sludge.

Off-site waste water disposal means that all waste water, sometimes in combination with storm water, is collected on a large scale via a sewer system. The collected waste water can then be treated in a central purification plant.

Intermediate scale facilities are defined as the whole range of well-known as well as experimental combinations of collection systems and treatment installations, that cannot be categorized as on-site or off-site, and generally take care of the waste water of a smaller part of a city or town. Examples, to be further discussed in *Chapters 4 and 6*, are shared or communal systems. In these options, every household has its own toilet facility, connected to a low cost sewerage

and a small central treatment installation serving typically 2-5 households ("shared" system) or 10-100 households ("communal" system). The effluent of the treatment facility (septic tank, high-rate anaerobic reactor, trickling filter) can be discharged into a drain or a sewer (small diameter and/or flat slope)

1.2.2 Procedure of the study

First, insight should be gained in the technical, managerial, economic, financial and institutional feasibilities of the possible sanitation strategies and programmes. They are determined by characteristics of the situation, like the provision of tap water, the average income of the consumers, and site-specific technical data.

Once a workable strategy and programme are known, the feasibility of anaerobic treatment in them can be determined. All feasible alternatives must be worked out. Only if the anaerobic technology proves competitive (more attractive at same cost, or cheaper at same degree of attraction), it may be considered successful.

However, to complicate matters, the feasibilities of the strategy and programme depend themselves also on the characteristics of available treatment technologies. For example, in a given urbanised area conditions may favour a strategy leading to sewerage the area, however if the local environment would be too fragile to receive the unpurified sewage, and if no sufficiently cheap treatment exists that can lower the pollution load to acceptable levels, the sewerage option may have to be replaced by an alternative strategy, like on-site sanitation, until the community is able to bear the full cost of sewerage plus centralised treatment. Unfortunately, in numerous locations financial, technical and other constraints are so pronounced that feasible solutions are scarce and "service-maximization" becomes in fact "public health risk-minimization". This interrelationship can be schematically represented in *Figure 1.1*.

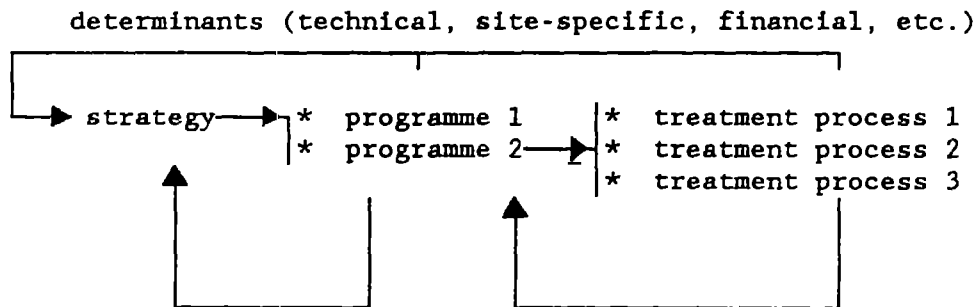

Figure 1.1 Iterative process for sanitation strategy development

Most studies on the feasibility of treatment and disposal technologies tend to focus on an isolated facility, which may be a reasonable approach in a rural or otherwise cleared setting. In a more densely populated area this may no longer be true: on-site pit latrines for example, which often form the economically most attractive solution when judged individually, may become unfeasible due to limitations in space and accessibility, or to the fact that a simple and cheap combined system can be constructed in favour of off-site alternatives. In other words, the present study attempts to base decision-making on the complete sanitation landscape involving large areas and all relevant aspects, rather than on treatment alone.

1.2.3 Organisation of the study

The **first chapter** briefly discusses the specific aspects of sanitation in developing countries. It introduces the technology options with regard to the treatment of waste water, as these are alternatives to the anaerobic option.

The **second chapter** identifies and describes in detail (i) the factors that determine the feasibility of sanitation strategies and programmes and (ii) the selection criteria for an optimal waste water treatment technology within such a strategy. Some determinants are more relevant for the overall strategy or programme selection, whilst others pertain more to the treatment technologies as such.

The determinants are.

- (i) feasibility of waste water collection and transportation systems (sewerage),
- (ii) site conditions with respect to the physical environment, the urbanisation pattern and existing service levels,
- (iii) environmental feasibility with respect to protection of surface water and/or ground water (includes specification of the treatment facilities, their removal efficiencies, and efficacy or reliability),
- (iv) financial and economic analysis of the sanitation strategy and sanitation technology,
- (v) institutional requirements,
- (vi) unit scale of the sanitation technology

These determinants can be combined in a matrix ("landscape") and they define the strategies and programmes that may be applied; in each option anaerobic treatment may or may not play a role. A major distinction between three classes of situations thus arises, of which the treatment facility scale (degree of centralisation) is the governing parameter

- on-site,
- off-site, and
- intermediate scale.

Chapter three describes the pros and cons of anaerobic treatment technology for domestic sewage. Five important pilot and demonstration plant data are reviewed.

The **Chapters four and five** concentrate on the two major sanitation options as identified in the "landscape matrix": treatment at on-site (household) scale, and centralised off-site treatment (city-wide). Within each option the position of anaerobic technologies is discussed in the light of the determinants mentioned in *Chapter 2*.

Chapter six describes sanitation programmes that combine and/or integrate on- and off-site options. These intermediate-scale combinations, though sometimes unconventional, may in some cases better suit the needs and targets of a sanitation strategy.

Finally, **Chapter seven** formulates conclusions and recommendations

1.3 Waste water management in developing countries

1.3.1 Sanitation and public health

The links between water quality and diseases have been investigated and described in much detail (Feachem *et al.*, 1983). Water that is not safe for human consumption can spread disease; inadequate facilities for excreta disposal can become pathways for transmitting pathogens to healthy persons. Coupled with malnutrition, excreta-related diseases can take a heavy toll in developing countries, especially among children. In addition, the presence of contaminated surface or ground water severely reduces the availability of raw water of sufficient quality to be used for consumption, fishing or recreation.

The existence of these links is now generally recognized, and so has the political importance of the provision of safe drinking water to the population. This recognition is largely due to the impact of the UN International Drinking Water Supply and Sanitation Decade, initiated in the Mar del Plata UN Water Conference of Spring 1977. It led to considerable progress on the implementation side: whereas in 1980 only 33% of the rural population in developing countries benefitted from water supply, this number had risen to 42% in 1985, the figures for the urban population remaining high during this period at approximately 75% despite the urban growth.

The health risks associated with waste water however, and the political weight of sanitation, have not yet received the same recognition. Of the rural population in developing countries only 16% had access to adequate sanitary facilities in 1985, against 13% in 1980. The coverage ratios for the urban population are

33 and 59% for 1980 and 1985, respectively (WHO, 1987; World Bank estimates are 10 to 20% lower, see Rietveld, 1988) Caution is required when interpreting these figures. Often the mere provision of a waste water removal mechanism like sewerage is already called adequate, thus shifting the health risk from the town or city to the environment (either the surface water in the case of sewers or drains, or, to a more limited extent, the ground water in the case of on-site sanitation with waste water percolation)

In general, it should be emphasized that in order to achieve public health benefits, equal attention should be given to improved water supply, sanitation facilities and public health education. This is illustrated in Figure 1.2.

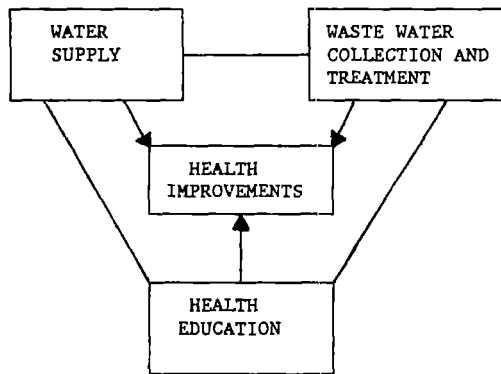

Figure 1.2 Relationship between health improvements (result), and water supply, sanitation, and health education (means)

As a rule, the costs for the provision of sanitation are, for the households, equal to or higher than the costs for water supply. Given the low average household income in developing countries, and the recommendation that these services should not consume more than 3-5% of this income, it becomes evident that conventional, truly satisfactory technical solutions are usually too expensive. In addition, the lack of experience and the weak institutional capabilities of the agencies responsible for urban infrastructure jeopardize cost recovery, operation and maintenance.

1.3.2 Urban and rural stress on the environment

The size and consequences of the sanitation problem vary considerably between the urban and rural setting, and between different rural settings. Population density is in this respect a major parameter affecting the exhaustion of the "pollution carrying capacity" of the natural environment in the vicinity of the settlement

This pollution carrying capacity determines how much waste can be absorbed by the ecosystems in the environment through what appear to be self-purification processes. The more limited this capacity (because of the small part of the "free" environment left over, or because of the fragility of the ecosystems) the more effort and thus money will be required to keep pollution in and near the habitat below dangerous levels.

The extent of the sanitation problem in rural areas should not be minimized: income is very low and cultural and institutional acceptance of technological solutions is even less secured than in urban communities. Yet the most simple and cheap solutions, like good drainage or leaching pit latrines, are in most cases already effective from a public health view as well as environmentally acceptable because the pollution intensity (e.g. expressed as load of pollutant to be absorbed per unit of time and per unit of surface available in the natural surrounding) is small. In addition, the agricultural activities close to the villages are an appropriate "sink" for the absorption of most types of human waste. Any other solution striving for higher pollution removal efficiency, however, would become rapidly financially unfeasible.

The urban setting on the contrary, is characterized by high population densities and, internally and at its perimeter, a stressed environment due to the very high pollution intensity and concurrent reduced size of the natural environment. As a consequence, to avoid degradation of the environment (surface water and ground water pollution, solid waste accumulation) more attention must be paid to planning in sanitation, and special technical measures must be taken to reduce pollution load more effectively, usually involving higher expenses.

Whereas affordability and positive interest for sanitation and environment protection pose no major problem to the small, rich part of the community, a majority of the urban dwellers lack the required level of education and financial strength to support the more complicated sanitation programmes at wider scale. It is therefore unlikely that high-rate treatment technologies will play a role in all urban and semi-urban areas.

The powerful growth of Third World cities deserves therefore special attention. Cities are environmentally unstable systems, and sustainable growth necessitates high investment in technology – for which the money often lacks in the Third World. In the developing countries the number of people living in cities has increased from about 300 million to 1.2 billion in the period 1950-1986. If this growth continues, more than half of humanity will reside in cities at the turn of the

Table 1.1 Size distribution of Indian urban settlements (CBPCWP, 1979 & 1980) Figures are based on 1971 census and adjusted for growth up to 1986

Category		Size (inhabitants)	Number	Total population ¹	
Municipality	class 2	50,000-100,000	190	18.5 million	2.3%
Municipal corporation	class 1	100,000-1,000,000	133	62.6 million	7.8%
Municipal corporation	class 1	> 1,000,000	9	45.4 million	5.7%

¹ Percentage pertains to ratio of population in the considered class to total urban + rural population

century. In Africa, the least urbanised continent, urban population grows 5% yearly, from 175 million today to 368 million in 2000. During the same period numerous Asian cities will have tripled or quadrupled their populations, e.g. Baghdad, Bombay, Dhaka, Jakarta and Seoul. In Latin America already 65% of the people live in the major urban areas. Of greater concern are the hundreds of less well-known cities with populations between 100,000 and a few million. *Table 1.1* provides a distribution of city sizes for India. Most of these cities do not enjoy the relatively favourable economic conditions of the country's metropolises, and may thus face even more serious constraints with regard to provision of urban infrastructure

In rural areas and towns with a predominantly agricultural environment sanitation needs to emphasize only removal of waste water from the habitat because of its pathogenic content, and possibly treatment in the form of pathogen removal (usually by toilet waste percolation into the soil). In the urbanised areas, where the surrounding environment is stressed and has a limited waste assimilation capacity, BOD and nutrient removal may become more important, besides the concern for the reduction of the risk of individuals coming into contact with sewage carrying pathogens

Rural sanitation will therefore gain little benefit from the development of efficient waste water treatment technologies that aim at BOD removal (like high-rate anaerobic technologies). In the rural areas of some countries, like the P.R. China, Nepal and India, advantageous use is made of farm- or village-scale digestion of manure and, sometimes, human waste, to generate modest amounts of biogas and fertilizer. In many another country such schemes have failed. This anaerobic application in sanitation, though not high-rate, will be briefly mentioned in *Chapter 3*. This report focusses on liquid wastes, and consequently primarily on the urban setting

1.4 Waste water treatment technologies

1.4.1 Waste water and its treatment

a. Domestic and industrial waste water

Under domestic waste water may be understood

- toilet waste water (black waste water), with a daily per capita flow depending on anal cleansing habits (with or without water) and on the type of toilet facilities;
- sullage from kitchen, bathroom etc with a daily flow and organic pollution load depending on in-house usage habits (laundrying, bathing, washing, etc.) and the level of water supply service;
- black waste water with sullage (grey waste water), and
- if domestic waste water is transported through a sewerage that also receives (part of) urban run-off water, it will include additional pollutants of different kinds, as well as additional flows of non-polluted drain water, subject to irregular variations of a large magnitude. These variations have considerable consequences for the design of the sewer or drain as well as the treatment system.

The waste water types can be schematically depicted as shown in *Figure 1.3*.

The flow pattern has hourly, daily and seasonal variations that may be very pronounced and affect design, operation and control of sanitation systems. Generally, industrial waste water is more concentrated than domestic waste water, its composition, flow and flow pattern are specific for each industrial sector. Normally the waste should be treated on the factory's terrain before being discharged in a sewer or river.

b. Objectives of waste water treatment

The objectives of waste water treatment may be the removal of

- Oxygen consuming substances (expressed as Biological Oxygen Demand BOD, Chemical Oxygen Demand COD, and Nitrogen Oxygen Demand NOD),

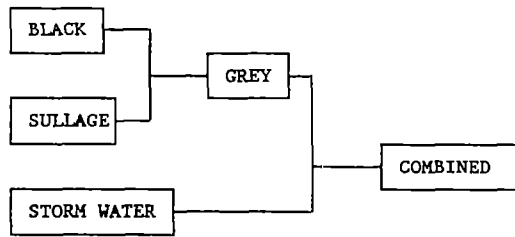

Figure 1.3 Types of domestic waste water

because discharging too much into surface water leads to depletion of dissolved oxygen and hence black, smelling and septic water, and fish mortality,

- Suspended Solids (TSS) and settleable solids that can increase water turbidity and settle out in channels, drains, sewers and receiving water bodies, where they may cause obstruction and rotting on the bottom,
- Nutrients (nitrate NO_3^- and phosphate PO_4^{3-}) to prevent excessive algae bloom in the receiving water (eutrophication).
- Pathogenic organisms, like some faeces-related bacteria, viruses, some protozoae and amoebae, particularly in their dormant state (cysts), and some helminths and their eggs (ova), a relation between occurrence of contagious diseases and access to contaminated waste water exists,
- Inorganic and organic micro-pollutants, that may disturb aquatic life, and end up in food chains

c. Classification of sanitation systems

The major distinction in sanitation systems is determined by their unit scale. In **on-site** treatment, waste flows are treated near the point of origin (usually household), in **off-site** treatment the waste water needs to be first collected and transported to a place at a certain distance (at the edge of the city) where it will be treated centrally. Transportation takes place under gravity or under pump pressure, but the latter implies investment and operation cost for pumps, as well as higher construction standards. In the case of off-site treatment of domestic waste water, the cost of the collection and transportation network must be balanced against the gain in the cost of centralised treatment which is due to the scale effect. Other factors may also argue for centralised waste water treatment: it is easier to maintain a high treatment efficiency in larger plants, and there may be reasons to discharge fully treated effluents on surface water rather than let it percolate into the soil. Annual costs of collection systems will be of the same order of magnitude as those of the treatment system. This explains the continuing interest in relatively simple on-site systems,

premising that (i) a particular technology of limited cost can be found, so that the sum of the costs for the on-site systems lies below that for a centralised treatment plant plus sewerage, (ii) this technology produces an effluent that either can be percolated into the soil or collected through a sewer/drain system of simpler and cheaper nature, or (iii) a combination of both

1.4.2 Waste water treatment

a. General

Waste water treatment systems can be divided into (micro)biological, physical, and physical-chemical processes. Amongst the microbiological processes one can distinguish aerobic and anaerobic processes. An overview of the various technologies is given in *Table 1.2*

Appendix 1 provides data-sheets of the main characteristics of the most important alternatives: aerobic high-rate processes, as well as low-rate anaerobic processes

The purification of waste water produces large amounts of **inert and organic sludge**, which have to be thickened, treated and disposed of. This is an important and expensive part of waste water treatment. This holds particularly for aerobic processes, where about half of the organic pollution is not converted into inert end-products, but into organic biomass, the "excess sludge." This sludge is usually a cumbersome product and often "unstable," *i.e.* it will rot in the air, causing severe odour problems. Anaerobic processes rely on microbiological conversions that produce much less excess sludge in a more stable (non-rotting) condition.

b. Conventional (aerobic) sewage treatment

Domestic waste water (sewage) in industrialised countries is commonly treated in a sequence of process steps. Most sewage treatment plants consist of a primary, secondary and, in those cases where advanced treatment is necessary, tertiary treatment. In **primary** treatment settleable materials (grit, sand, large organic matter) are removed by straightforward settling, typically 20-25% of the sewage BOD can thus be removed. **Secondary** treatment is usually aerobic and involves microbiological oxidation of the organic pollutants (BOD and usually NOD) by mechanical addition of air employing powerful rotating surface aerators, compressed air or by letting the water trickle down in thin layers over some reactor filling material. **Tertiary** treatment is more expensive, and much less widespread. By applying biological or physical-chemical methods it aims at further polish-

ing of the effluent, at removal of nitrates, phosphates, and, in a number of cases, of pathogens.

The predominantly organic **sludge** obtained in these treatment steps is separated, thickened, and commonly stabilized in aerobic or anaerobic digestion tanks. Finally it is usually dewatered before it is applied as fertilizer, soil conditioner, or dumped (if heavy metal content or economic conditions do not allow other end-uses)

Such conventional treatment is costly and complex, requiring trained personnel for management, operation and maintenance. Efficiency and cost considerations generally call for centralised treatment, which necessitates long sewage collection and transport lines. For developing countries simpler and cheaper systems should be able to better address the prevailing economic and institutional constraints; this may result in either cheaper central treatment, like in ponds if land price is very low, or in cheaper or smaller sewage collection systems (*i.e.* applying decentralised complete treatment, or pre-treating waste water so that this pre-treated waste water can be transported in sewers of cheaper construction, or diverting the waste water into the soil by percolation).

c. Anaerobic treatment

For five years, positive experiences with the anaerobic treatment of various types of domestic waste water indicated that this novel technology may become an appropriate tool in waste water management. Conventional, aerobic waste water treatment has been extensively applied in industrialised countries, but has the reputation of being expensive and requiring specialist supervision. Anaerobic waste water treatment has been introduced on full-scale on various types of **industrial waste water** for over a decade, both in cold and warm climates. Results have been in most cases successful, though a number of operational problems remain partly unsolved. Newly developed anaerobic processes, carried out in specially designed concrete or steel reactors, feature high-rate qualities and short retention times which generally mean reduced construction costs. "Conventional" anaerobic treatment includes application of for example anaerobic ponds, it has been applied successfully since long but requires much longer retention times.

The application to more dilute **domestic waste water** appears to be restricted to the relatively warm sewage, up to now 20 °C seems to mark the lower practicable limit.

Anaerobic waste water treatment can become an attractive alternative because

- under tropical climatological conditions diluted waste water like sewage can be digested efficiently, as

has been shown on a pilot scale. This positive effect becomes less pronounced in temperate climates, or in climates with extreme low temperatures for prolonged periods (mountainous areas, deserts). *Figure 1.4* provides a world map indicating the regions where efficient anaerobic treatment is likely to be possible (white central area along the Equator), as well as the regions where it becomes less obvious but still possible due to under-optimal ambient temperature ranges (shaded areas), it should be noted however that, particularly if the reactor is well insulated (*e.g.* when the reactor lies below ground level), the day-average sewage temperature is a more correct predicting parameter than the air temperature. Most less industrialised countries fall in the regions with favourable climate; exceptions are probably mountainous areas in northern India, Nepal, some parts of South America and Africa as well as parts of P.R. China. These areas however do not represent a major share in terms of population,

- process experience on demonstration scale shows a considerable process stability as well as flexibility to absorb shock loads and adapt to abnormal conditions;
- despite lower removal efficiencies than can be achieved by aerobic treatment, anaerobic treatment may play a major role in overall reduction of pollutants, notably BOD, in order to improve the BOD removal efficiency an anaerobic post-treatment may be useful,
- high volumetric loadings and the absence of major mechanical equipment indicate economic advantages;
- significant lower sludge production rates reduce the costs for sludge treatment/disposal, the sludge is well stabilized.

The above remarks pertain to anaerobic reactors featuring one reaction chamber. Recent experiments indicate that with a two-stage or three-stage reactor higher treatment efficiencies can be obtained.



Figure 1.4 World climatic zones based on climate map in the Time atlas of the World. Anaerobic sewage treatment is definitely possible in the equatorial zone within the striped lines because of generally high ambient (sewage) temperature. Anaerobic sewage treatment is probably feasible in the grey-shaded areas (usually a sufficiently elevated sewage temperature). In white areas it may usually prove too expensive compared with other treatment methods.

Between the striped lines: Climate A, rainy climate with no winter, average temperature in coldest month above 18 °C. Grey-shaded areas: Climate B, dry climate, all months above 0 °C. Subtropical and tropical deserts: Climate C, humid, subtropical. Coolest month average above 0 °C., warmest month above 22 °C.

Table 1.2 Brief overview of existing waste water and sludge treatment technologies**1.2.a** Physical treatment (usually in conjunction with other treatment)

Rough screening

Sedimentation (settling) grit removal, primary sedimentation, clarification, secondary (biomass) sedimentation

Flotation

Filtration (on sand or granular active carbon bed)

Ultrafiltration (on membranes)

Straining

1.2.b Aerobic (micro)biological treatment**Processes with suspended biomass**Activated sludge treatment with - surface aeration
- compressed air aeration

Oxidation ditch (carousel)

Phostrip process

Aerated lagoon

Facultative pond (oxygen provided by diffusion and via algae)

Facultative pond with floating aquatic macrophytes (FAM), reed, fish, etc.

Nitrification process

Biological phosphorus removal

Processes with attached-growth (immobilized) biomass

Trickling filter

Biological rotating disc (RBC, biodisc), rope contactor

Slow sand filter, intermittent soil infiltration

1.2.c Anaerobic (micro)biological treatment**Processes with suspended biomass**

Up-flow anaerobic sludge blanket process (UASB)

Anaerobic contact process

Anoxic denitrification

Processes with attached-growth (immobilized) biomass

Anaerobic filter

Fluidized/expanded bed process (i. a. AAFEB, fluidized sand carrier)

Anoxic denitrification

1.2.d Physical-chemical treatment

Coagulation/flocculation

Stripping/desorption of gases (e.g ammonia, hydrogen sulphide)

Adsorption on active carbon

Ion exchange

Oxidation with oxygen, ozone, chlorine, chlorine dioxide, sodium permanganate, etc

Disinfection with - chemicals (mostly chlorine)

- ultra-violet rays (sunlight)

- silver, copper ions

Breakpoint chlorination to remove ammonium

1.2.e Treatment of excess sludge

Physical thickening

Stabilization/digestion. - aerobic by prolonged aeration

- anaerobic

Disinfection - heat treatment by aeration

- heat treatment by external heating

- lime treatment (high pH control)

Re-use as fertilizer, in liquid or dried form

Dewatering on sand bed, in belt sieve press, in pressure filter, in centrifuge

Tipping (only in dried form)

Incineration (only in dried form)

Composting (in combination with solid refuse)

1.2.f Typical on-site technologies

Dry - pit latrine

- vaults, buckets

- composting toilet

Wet - leaching cess-pool with percolation into the soil

- septic tank with percolation bed

- up-flow anaerobic sludge blanket (UASB) with percolation

- ditto, but with supernatant drained above ground

- small fish pond

1.2.g Natural systems

- Overland flow

- Use as irrigation water, aquaculture, pisciculture

- Weiland system

2 Strategies and Determinants of Sanitation

2.1 Introduction

In order to assess the position of anaerobic treatment processes in sanitation programmes, the **strategies** that assist in implementing the objectives of the sanitation, and the **determinants** that define the feasibility of strategy, programme and technology must be identified. This will help to rationalize and simplify the complex sanitation “landscape.”

To realize a sanitation programme at minimum cost several options are available. The technical characteristics for classifying these options are:

- whether the sanitation option requires water for proper performance and/or flushing/transportation of domestic waste flows; this leads to a basic division in dry and wet systems;
- whether the sanitation option relies technically speaking on on-site or off-site treatment and/or disposal of wastes; this may also lead to the distinction of a third, intermediate scale.

Additional criteria of a technical and non-technical nature are needed to judge which sanitation option is most appropriate in a particular situation

The determinants described in this Chapter assist in selection of the optimal sanitation option for a specific local situation. Yet one should realize that in reality each town or neighbourhood calls for an individual sanitation study, yielding probably a mix of appropriate solutions to be applied simultaneously

2.2 Available technologies for human waste disposal

2.2.1 On-site sanitation systems

a. Dry systems

Common dry on-site sanitation systems without water supply are pit latrines equipped with a squatting slab or a pour-flush bowl. The faecal material (sludge) digests anaerobically, it densifies and matures in the pit, while the small amount of liquid (largely urine) is allowed to percolate into the soil

These on-site sanitation facilities commonly serve one to a few households and function well, provided population density and water use for flushing in the toilet are rather low. The structures have mostly a

permanent character; regular collection of sludge (once every few years) is to be carried out when the pit is full. This is usually carried out by individuals with simple equipment and a small cart, or, in more wealthy areas with sufficient access by special trucks

As in-house water consumption is very low (typically ≤ 30 L/cap.d), sullage production is minimal as well; it finds its way over the surface in gutters or drains. It finally may infiltrate into the soil or be discharged into surface waters. Contrary to toilet waste it does not contain faecal matter and is thus more or less free of pathogens; on the other hand it represents an organic pollution load (BOD) of the same magnitude.

In China, Korea, Japan, some parts of the Indochinese subcontinent and India human excreta are traditionally collected at night (nightsoil) in a bucket placed under the squatting slab. The bucket is emptied on a daily basis by a cartage service and brought to a central collection station. The waste is anaerobically stabilized and commonly reused as fertilizer in the rural areas near the city or town. These systems however are losing their popularity because of the public health risks to the nightsoil collectors, and the growing availability of industrial fertilizers (easier to handle by the farmers, and having higher nutrient content).

It may be clear that high-rate anaerobic treatment needs liquid waste (sewage) and that it can therefore not be applied on dry sanitation systems

b. Wet systems

The introduction of a piped water supply has created a waste water problem. The provision of water through standposts or individual house connections resulted in rapid increase of waste water production. Households enjoying the convenience of a piped water supply therefore need an appropriate sanitation system to deal with the increased waste water flows arising from the use of pour-flush or cistern-flush toilets. On-site leaching pits (soakaways), leaching trenches, or off-site waterborne sewerage are suitable for the disposal of liquid waste flows.

The use of on-site facilities with local percolation into the soil is being progressively reduced in urban areas because of the potential public health impact on ground water quality. Even in many urban residential areas with a piped supply, the often cheaper shallow

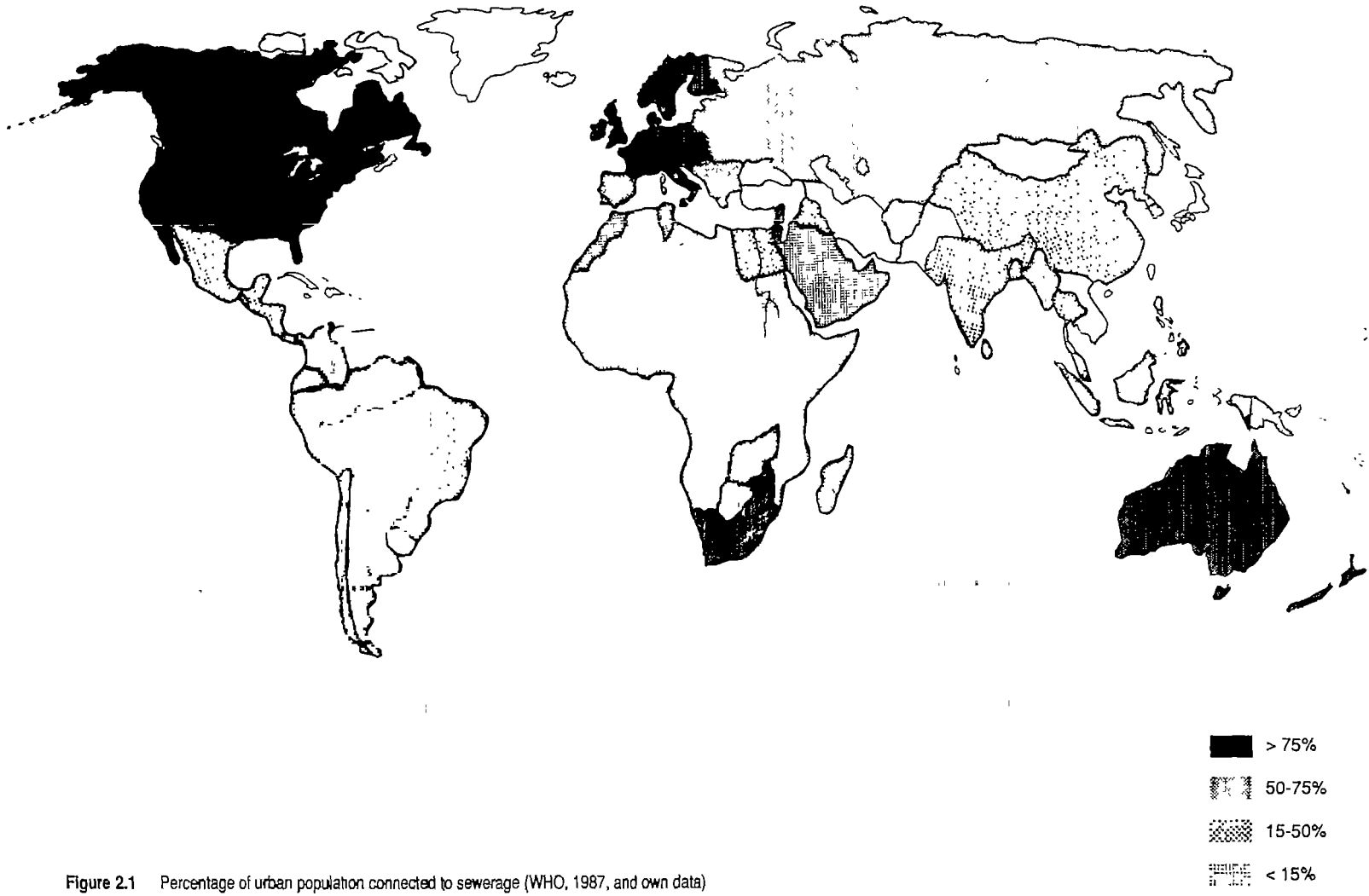

Figure 2.1 Percentage of urban population connected to sewerage (WHO, 1987, and own data)

ground water is used for household purposes. Organic and bacterial pollution of this resource by on-site sanitation can to some extent be prevented by keeping sufficient distance between shallow wells and the sanitation facility. This may prove too difficult in densely populated urban areas. In addition, the sullage can usually not be percolated, and is drained over the surface to a receiving surface water. Sewerage and possibly off-site treatment are then to be considered the only technically feasible alternative to cope with increased stress on the ground water

Sludge from the pit (septic tank, leaching pit) is collected by individuals with a small cart, or with vacuum trucks

2.2.2 Waterborne sewerage

The traditional approach to urban sanitation has been based on experiences in industrialised countries where the highest level of service (and convenience) has been applied, namely conventional sewerage followed by primary, secondary and occasionally tertiary treatment. These systems rely on relatively high water consumption levels (> 100 L/cap.d) in order to carry pollutants and settleable matter through the sewerage. However, there are several reasons why such waterborne systems are inappropriate for many low-income urban communities in developing countries.

- Conventional sewerage followed by treatment before final discharge was in many typical cases found to be the most expensive of all sanitation alternatives in terms of capital investment cost, except for very high population densities (*Table 2.1*). Consideration of the operation and maintenance cost would however sometimes lead to a different conclusion

- Proper performance of conventional sewerage can only be ensured if sufficient water is supplied (Cairncross and Feachem, 1983). At present this would pertain only to 35% of the urban population in the world.

- In unplanned urban residential areas with high population densities, laying of sewers may require the demolishing of a substantial number of houses or squatter areas, which often will be politically and socially unacceptable.

- Sewerage is a complicated type of urban infrastructure, necessitating institutional, organisational and/or technical capabilities that are often lacking

Recognizing the above limitations, conventional sewerage-based sanitation is in many cases not the most feasible solution responsive to the needs of a rapidly growing urban population in a developing country, except for specific, well-organised and fairly rich urban communities. It is therefore not surprising

Table 2.1 Indicative unit construction costs in US\$/cap (WHO, 1987)

Region	Sewer systems ¹	Other sanitation options
Africa	150	116
Americas	150	80
South East Asia	80.5	20
Eastern Mediterranean	480	345
Western Pacific	444	73
LDCs ²	150	120

¹ Excluded waste water treatment

² Least Developed Countries

to see that in developing countries the urban coverage by sewerage is still low, with figures between 10 and 20% remaining constant over the last decade (*Table 2.2*). In spite of the increasing demand for adequate sewerage systems (as a result of increasing water consumption levels and higher population densities) little has been achieved as yet. It can be expected that in the future, sewerage systems, sometimes in an adapted or simplified form, will be selectively introduced in the financially stronger areas.

Table 2.2 Coverage (%) by conventional sewerage (WHO, 1987)

Region	1970	1980	1985
Africa	8	11	12
South East Asia ¹	33	30	41
Latin America	36	42	41
Western Pacific	27	17	12
Europe	81	-	84

¹ Total urban sanitation coverage

The figures show that sewerage coverage has nevertheless kept pace with the fast growth of urban population. Figures must, however, be considered with caution: storm water drainage systems with underground conduits are sometimes also defined as sanitary sewer systems. *Figure 2.1* provides a spatial overview of the relative contribution of sewerage to urban sanitation in countries around the world

Waterborne sewerage with individual house connections is obviously not feasible in low-income urban areas, although population densities are often excessively high. Often shared or public on-site facilities can be installed at lower per capita cost. In spite of the

small per capita water consumption rates fairly large quantities of waste water are produced at these facilities, particularly when they are combined with a public water supply tap. Connection of these point sources of waste water to some kind of off-site sewerage system may be worth considering as the required sewer length per capita can be rather small compared to the situation with individual connections

2.3 Determinants of sanitation programmes

The factors that determine the selection of the most feasible sanitation programme for a particular set of conditions within defined objectives are summarized in *Table 2.3*.

Table 2.3 Determinants of sanitation programmes.

Site conditions - physical environment	(Section 2.4)
- urbanisation pattern	
- existing service levels	
Environmental feasibility	(Section 2.5)
Institutional aspects	(Section 2.6)
Community involvement	(Section 2.6)
Socio-cultural aspects	(Section 2.6)
Economic and financial aspects	(Section 2.7)
Technological factors - removal efficiency	
- efficacy/process stability	
- operational requirements	

The technological factors are treatment- and not programme-specific, and will be discussed in the *Chapters 3, 4 and 5*, when comparing the aerobic and anaerobic treatment technologies.

Table 2.4 Site conditions of importance

Physical environment	- climate, - topography, soil stability; - percolation capacity, - hydrogeology / flooding,
Urbanisation pattern	- present and projected population, - present and projected population densities, - degree of urban planning,
Existing service levels	- service levels for water supply, sanitation, and other infrastructure

2.4 Site conditions

2.4.1 General overview

Specific site conditions determine the technical feasibility of on-site, off-site or intermediate-scale sanitation schemes (*Table 2.4*).

2.4.2 Physical environment

Climatic conditions such as the frequency and intensity of rainfall determine the requirements for drainage and/or sewage collection. Generally, the rainfall pattern in tropical countries (high rain fall intensities) economically favour separate systems for storm water and sewage disposal. Flood control is important in those areas where on-site sanitation systems may be subject to flooding thereby creating potential public health hazards.

The average **temperature** of sewage and its fluctuations influence biological degradation processes and destruction of pathogens. Especially anaerobic degradation processes are favoured by increased temperatures. Anaerobic treatment of sewage will definitely not be feasible below 12 °C, and sewage temperature should preferably be above 20 °C. This explains the geographical distribution of potential of anaerobic waste treatment as indicated in *Figure 1.4*.

Data on **topography** determine whether gravity solutions for collection systems can be applied. In flat areas extra excavation and pumping may be required, thereby considerably adding to the capital as well as running cost of off-site sanitation systems.

Soil stability affects the construction and site preparation works for on-site as well as for off-site systems. Additional support structures may be needed to reduce the risks of collapsing unstable soil formations, while excavation may on the other hand be prohibitively cumbersome in areas with rock formations near the surface.

Soil permeability influences the liquid percolation into leaching pits or trenches and affects the run-off coefficient for stormwater. In case of poor soil permeability (less than 10 L/m².d) excessive percolation areas may be required, while percolation rates of over 50 L/m².d for sewage and 100 L/m².d for sullage result easily in ground water pollution problems.

Ground water tables close to the surface will reduce the percolation possibilities for on-site systems. For sewerage the high water infiltration (leakage) rate per meter of sewer length may result in considerable dilution of the waste water. This is particularly disadvantageous for anaerobic treatment processes as they perform best for medium to high strength waste.

Depending on the situation more aspects may need

to be taken into consideration such as soil composition (influencing for example pathogen dissipation in the ground) and potential risks for earthquakes which both affect construction and design.

2.4.3 Urbanisation pattern

The majority of the urban low to medium income population lives in townships, which range from unplanned high density squatter areas, which usually lack the provision of basic public services, to planned housing areas where public services are more easily made available. The prevailing urbanisation pattern and type of housing largely determine the availability of space for on-site sanitation/percolation systems and the access possibilities for vacuum trucks to desludge pits, tanks or vaults.

As discussed in *Chapter 1*, trends in demography in developing countries indicate that especially urban population grows rapidly in size. As a consequence of increased population densities, the easy availability of land for on-site sanitation systems gets reduced, while the land costs rapidly increase. Moreover, on-site disposal of increasing amounts of human wastes may result in overstressing the environmental pollution carrying capacity with consequent public health and environmental hazards.

In general, economies of scale can be realized in terms of land requirements per capita (m^2/cap) when **shared, communal** or **public** sanitation systems can be used. Shared and communal arrangements allow individual in-house toilet facilities, but convey the toilet waste to a shared (by a few households) or a communal (for 10 to 110 households) on-site treatment facility. Public facilities combine toilets and treatment in one small building, serving a small neighbourhood. These facilities can operate with on-site effluent percolation, but the larger ones can be gradually upgraded with a transportation system for the liquid supernatant to an off-site discharge or treatment. In the latter case they can treat not only black but also grey waste water.

It is not easy to define at which population density on-site sanitation systems become less feasible, but it can be stated that waste percolation into the ground will render on the one hand any local shallow ground water unfit for human consumption (unless boiled)

when density exceeds 150-200 cap/ha, whilst on the other hand in more densely populated quarters individual on-site facilities may become less feasible compared to off-site alternatives because of land use¹

Both from a technical and a financial point of view, on-site sanitation systems characterized by some but limited sewer construction and very simple means of disposal of pathogen contaminated water, can be expected to be dominant for many decades to come. This would not only hold for low population density areas but also for high density areas as low water consumption levels in many residential areas do not yet allow for conventional sewerage.

2.4.4 Existing service levels

The existing service levels for infrastructural facilities provided to residential areas refer to storm water drainage, access roads, power and water supply and human waste and refuse management.

Existing storm water facilities affect design and possible application of sewerage systems. Drains may convey sullage at the surface, it is common engineering practice not to allow any black waste water or effluent in the open surface drains, but in many (developing and industrialised) countries in reality many septic tanks and leaching facilities discharge illegally their supernatant into drains. Roads and footpaths determine the access to on-site facilities for desludging as well as run-off coefficients for storm water

Table 2.5 Daily water consumption per capita as function of service level (IRC, 1986)

Type of Water Supply	Water Consumption	
	Average (L/cap day)	Range (L/cap.day)
Communal water point (e.g. well or standpost)		
- at considerable distance (> 1000 m)	7	5-10
- at medium distance (500-1000 m)	12	10-15
Village well walking distance < 250 m	20	15-25
Communal standpipe walking distance < 250 m	30	20-40
Yard connection (tap placed in house yard)	40	20-80
House connection		
- single tap	50	30-60
- multiple tap	150	70-250

¹ To illustrate this basic point, reference is made to, for example, the recent Indonesian five-year urban infrastructure plan (REPELITA V, 1989-1994) which states that "areas with population densities between 150 and 250 cap/ha need special care in deciding which on-site disposal system is to be used. Project areas with over 250 cap/ha shall be classified as densely populated and shall not use on-site excreta disposal facilities" (IUIDP, 1988). Whether this standard approach is financially feasible remains a matter of discussion, however.

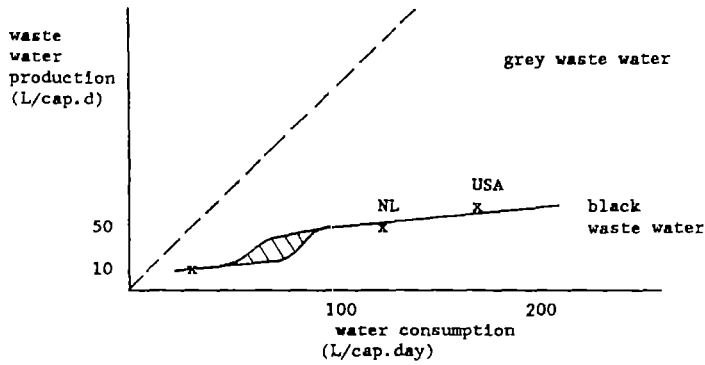

Figure 2.2 Waste water production as function of water consumption levels (Data obtained from: Feachem, 1983, Van der Graaf *et al*, 1988, de Kruijff and Macoun, 1988, RIVM *et al*, 1988).

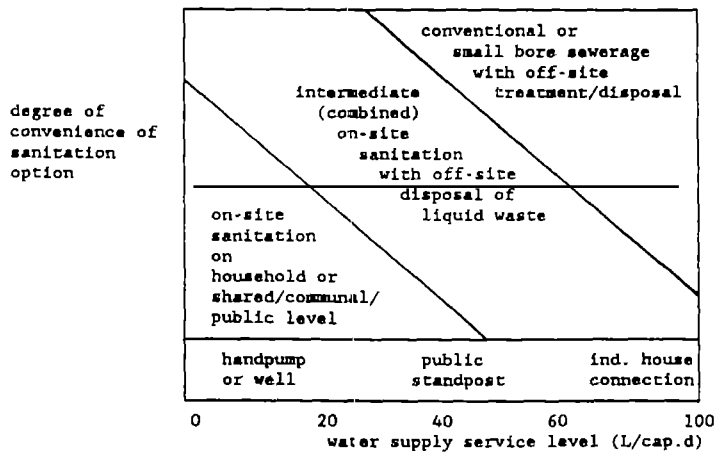

Figure 2.3 Effect of water supply service level on sanitation selection (adapted from Veenstra, 1988)

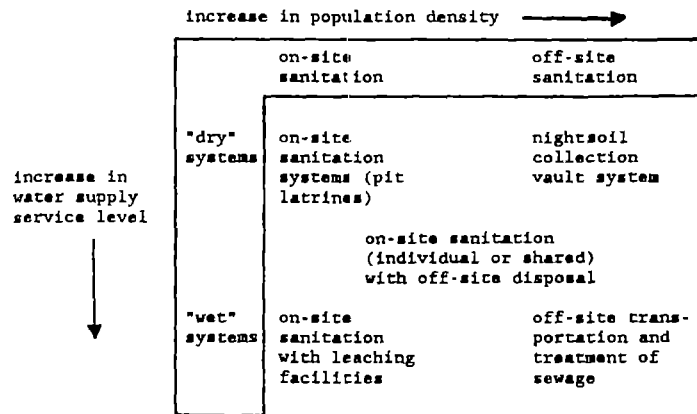

Figure 2.4 Matrix of sanitation technologies in function of water supply service level and population density

drainage. Well organised solid waste collection is a prerequisite for successful off-site sanitation as it must prevent clogging or blockage of drains and sewers by garbage uncaredly disposed of by the local community.

The water supply service level directly affects the feasibility of sanitation systems. With increased water supply service level the domestic water consumption increases, as is illustrated in *Table 2.5*.

Commonly, existing sanitation facilities are upgraded by the people themselves to pour-flush or cistern-flush toilets to increase private convenience. This results in the increase of toilet waste water production from about 2 up to 40 L/cap d.

The upgrading to wet sanitation systems leads to a need for water for flushing the wastes. In addition to the increased toilet waste water, the sullage water production may be even more affected by the increased water consumption rates as indicated in *Figure 2.2*.

With increasing water consumption it becomes more difficult to dispose of the higher waste water flows on-site. Therefore intermediate-scale or off-site sanitation may become more feasible. *Figure 2.3* may be indicative of a landscape of sanitation alternatives as a function of water supply level.

Integrating the effects of population density and water supply service level results in a landscape matrix indicating the potentials for on-site, intermediate-scale and off-site systems (*Figure 2.4*).

2.5 Environmental feasibility

Water resources must be protected against pollution or contamination, especially when they are expected to receive the waste water from large densely populated areas, in order to safeguard public and environmental health. Also other water uses, for example irrigation, need consideration and may influence the sanitation strategy.

2.5.1 Surface water protection

As for **surface water**, most countries have established waste water discharge standards inspired by European and American experience, yet in most developing countries they are not (fully) enforced given the considerable technological, institutional and financial efforts implied. Despite this apparent lack of hard guidelines, there is little doubt that one should take a long-term perspective, anticipating increasing concern for water quality management.

Typical effluent discharge standards to be met by Dutch waste water treatment plants are BOD < 20 mg/L and TSS < 20 mg/L. Depending on the receiving

surface waters, more stringent quality criteria can be set with respect to BOD, TSS and nutrients. If public health considerations are to be incorporated in the quality criteria, the European guideline for recreational waters can be indicative. In *Chapter 5* more detailed discussions will focus on quality criteria to be met in developing countries.

National governments will generally tend to set discharge standards on the safe (stringent) side, as long as these standards are not officially agreed upon, or enforced, it is unlikely that local government or regional authorities will be ready to invest heavily in waste water treatment to achieve some "intermediate" degree of purification. They will either postpone decisions, or prefer proven approaches. Innovative treatment technology should therefore be able to fully replace proven options, or form part of an hybrid solution whose efficacy cannot be doubted.

The purification (removal) efficiency of aerobic and anaerobic reactors in the context of this study can be described by following water quality parameters

- Oxygen consuming substances: usually expressed as BOD (5 day, 20 °C), COD, and NOD, this class of compounds is of primary concern as they affect strongly the vulnerable oxygen balance of receiving water bodies,
- Suspended solids, expressed as Total Suspended Solids (TSS or SS), and Settleable Solids, these solids increase water turbidity, and may settle out in the receiving water,
- Nutrients, i.e. N and P containing compounds, both may create problems if discharged into slowly flowing water (eutrophication), but on the other hand they are valuable components in re-use schemes. N containing compounds, if in reduced form (Kjeldahl-nitrogen or ammonia), will be slowly oxidized by nitrifying bacteria in surface water exerting a high oxygen demand (NOD);
- Pathogens can be roughly divided in viruses, bacteria, protozoae (especially in the form of persistent cysts) and helminths (of which the ova are of particular concern). These categories do have their own specific removal mechanisms in treatment plants.

Table 2.6 lists a selection of Asian, African and South American effluent standards. They come close to what is practised in industrialised countries and are usually based on the same considerations, those standards are therefore fairly representative for most countries in the world.

The above standards specify the quality in terms of oxygen consuming substances. In general, typically three discharge standard classes with increasing efflu-

Table 2.6 Effluent standards in 5 representative developing countries. Indicated are maximum allowable values

Country	BOD (mg/L)	NH ₄ ⁺ + NH ₃ (mg/L)	TSS (mg/L)	pH	Temp (°C)
India ¹	30	-	100	5.5-9.0	-
Tanzania ²	30	10	no sludge formation	6.5-8.5	-
Brazil ³	60, or 80% removal	-	settl. sol. ≤ 1 mL/L	5-9	40
Thailand ⁴	20 ⁽⁶⁾	Nkj ≤ 40	30	5-9	40
Philippines ⁵					
Class AA	30	-	50	6-8.5	40
Class D	50	-	75	6-8.5	40

¹ For domestic and most industrial waste water

² Ministry of Health, April 1977

³ State of Sao Paulo, May 31, 1976

⁴ Drafted standards by National Environmental Board, Nkj stands for Kjeldahl-nitrogen, covering also ammoniacal N

⁵ 1982. Class AA receiving water intended for water supply with minimal treatment, Class D receiving water suitable for irrigation and industrial purposes.

⁶ Depends on size of polluting unit

ent quality are used, the average cost involved to meet these standards is for each increased quality class much higher:

- (i) BOD ≤ 50 mg/L,
- (ii) BOD ≤ 20 mg/L;
- (iii) BOD ≤ 20 mg/L, and > 75% nitrification.

In addition, a fourth quality objective is to restrict the discharge of nutrients to prevent eutrophication of the receiving water body, by eliminating nitrogen, phosphorus, or both. This "tertiary" treatment is very significantly adding to the treatment cost.

- (iv) BOD ≤ 20 mg/L, > 75% nitrification, and removal of NO₃ by biological denitrification, and P removal to typically 0.5 mgP/L.

2.5.2 Ground water protection

On-site sanitation may create considerable pollution of **shallow ground water**. Percolation systems do not ensure pathogen removal, as micro-organisms can travel vertically 10 to 30 m into the ground, especially in areas with high soil permeability. Once reaching the ground water table, distribution of pathogens in horizontal (flow) direction can be considerable. Shallow water wells are to be carefully positioned at sufficient distance from the percolation point to protect the well water. This cannot be realized any longer at population densities above 150-200 cap/ha. Shallow well water in densely populated quarters can also become contaminated because of inadequate well protection at the surface, the use of contaminated buckets, and the infiltration of uncontrolled run-off flows. It must be emphasized once more that any serious health impact

can only be realized when safe water supply, adequate waste disposal and a general public awareness of the related health effects are ensured.

A second ground water pollution type provoked by black waste water percolation concerns nitrate accumulation. Nitrate level in drinking water should not exceed 50 mg NO₃/L (WHO, 1984), but in congested areas it easily exceeds this threshold, as reported in several cases.

Poor operational control of pits or septic tank systems frequently leads to irregular desludging services. As a result, soakaways and leaching pits get clogged and pits and tanks overflow into nearby drains. This leads to pathogens being conveyed with the drainage water as their concentration has hardly been reduced in septic tanks or leaching pits. Although the epidemiological implication is still unclear, open drains with contaminated water do not necessarily represent a direct health hazard provided they are well "protected," *i.e.* not accessible, and lined. Common engineering practice however, aims at full sewerage.

2.5.3 Other environmental concerns

Secondary issues that may occasionally limit the applicability of sanitation systems are odour nuisance, noise hindrance, insect breeding, safety risks, aerosol formation, and landscape spoiling.

2.6 Institutional development, community involvement and socio-cultural aspects

2.6.1 Institutional development

In order to be successful, water and sanitation projects require an institutional framework that allocates authority and responsibility for planning, marketing (consumer relations), design, construction, operation and maintenance, and monitoring for the schemes. A poor or incomplete institutional framework prevents satisfactory performance of any sanitation technology even when they are, technically speaking, properly designed and constructed. Too often no adequate division and allocation of responsibilities at community, municipal or central government level is provided resulting in malfunctioning and rapid deterioration of the systems.

In general, the institutional requirements increase with the size and complexity of the programmes but not necessarily with the unit scale of the applied sanitation technologies.

Off-site or intermediate-scale programmes involve considerable public investment and operation and maintenance (O & M) expenditures. They tend to be demanding in their technical as well as their managerial and marketing² components. They also require the commitment of different levels of the government and pertain to different sub-sectors that need to cooperate. Different aspects will be discussed in more detail in *Chapter 5* when dealing with the performance of anaerobic reactors.

Although the larger part of the investment is off-site, considerable work needs to be done at the household level (house connection, grit and fat trap, etc.). As a consequence, off-site programmes are also very sensitive to the commitment of the communities that are asked to connect to the network.

2.6.2 Community involvement

The only guarantee that implemented sanitation measures will be successful and lead to improved public health, is that the stimulus comes from the population itself, and that the population is well aware of the need of the measures.

On-site sanitation schemes and facilities may be completely or partly managed and financed by the users themselves. The role of the government authorities as well as that of non-governmental organisations may be important nonetheless to promote sanitation,

for example through public information campaigns, to assist technically (desludging services), to finance local communities that agree to participate in programmes, and in general to orient initiatives and monitor progress. Effective communication between the community and its spokesmen on one side, the local official representatives, and the different authorities on the other side, is a prerequisite. For ensuring long-term satisfactory performance of sanitation investments, community involvement can take various forms, e.g. the consultation with government during the identification and planning phase, the setting-up of a local structure (agreement, institution) that will take responsibility for the technical and/or financial management of the project once finished, and the provision of labour (self-help) during construction, operation and maintenance which helps to lower financial investment cost.

An increased degree of **sharing** (more than a few households participating in the ownership of a facility) means a lower degree of individual commitment from an owner, that can however be compensated by a higher level of local institutionalisation. Such institutionalisation is more efficient because of a scale effect and because it allows for some specialisation. Solid waste collection provides a good analogy: as long as each individual household is responsible for its own garbage transport and disposal, the garbage tends to become dumped in the drain near the house, if however, the community has been made aware of the importance of appropriate garbage removal, it may be willing to contribute financially and in kind to a joint effort (assisted by government) to keep the environment clean. This is of relevance to sludge removal from on-site sanitation facilities and its disposal, which are classic weak spots in those programmes. If on-site facilities are shared, their owners may appoint (and pay some money to) a caretaker. Such appointees are easier to supervise and train by local government, and can be better held accountable.

A critical step in the project cycle (and depending on the socio-cultural background of the community it may be the crucial one) is creating a high degree of awareness within the community of the advantages of the sanitation programme; this must lead to acceptance of the idea and commitment of the group to support the infrastructure. Commitment involves the willingness to pay and to contribute in kind to the construction and maintenance of the facilities. Commitment also raises the sense of ownership and responsibility of the community. This commitment can be notably fostered through preliminary intensive information and marketing campaigns, and involvement of the community in the process of planning,

² Marketing covers for a large part the relationship between the project and its beneficiaries. It implies / a the "selling" of the project to the community, but equally the adjustment of the project to its wishes and acknowledged needs.

selection of certain design criteria and the organisation of the institutional set-up that will manage the on-site facilities. Such a process may take a long time before the actual work can begin. In this process mediators or facilitating third persons, who are knowledgeable and are trusted by the community, are instrumental in enhancing communication.

A major task of the institution is to collect and manage the financial **contributions** (fees) and **charges**. In the case of off-site sanitation the investment is primarily carried out by the government authority; charge collection is often taken care of by the same or a related authority (e.g. the water supply company).

Connection fees are to be paid per house connection. A common problem is that in spite of the existence of a sewer people refuse to connect their houses because of the financial consequences involved. Better practice may then be to collect financial contributions through the water bill via the water supply company.

The investments at the on-site level can be the responsibility of either the authority or the community; in both cases an appropriate charge collection institution needs to be installed. In the case of on-site sanitation, investment is primarily the (financial) responsibility of the house owner or the community. This leads to a different institutional framework as is illustrated by Orth (1988) in *Figure 2.5*. If the community has taken the initiative, an institutional set-up needs to be developed capable of collecting the contributions and managing the funds in a sound manner.

Table 2.7 gives a brief overview of the possibilities for community involvement.

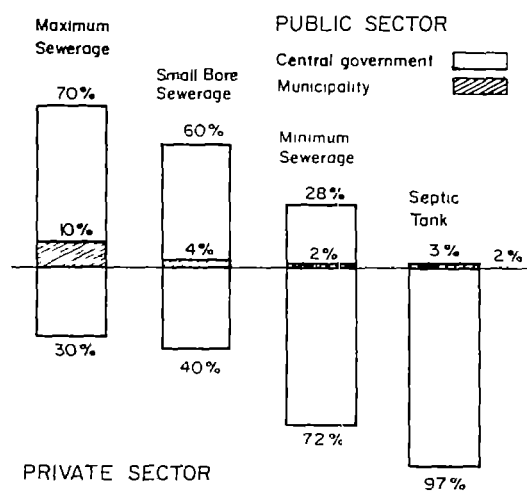

Figure 2.5 Distribution of capital funding between the public and private sector for four sanitation options for a Thai case (Orth, 1988).

Table 2.7 Identification of forms of community involvement. The Table reckons with 4 entities, the community at large (comm), its representative (rep), a mediator (med) and an appointed caretaker (app)

Activity	Project scale		
	On-site	Intermediate	Off-site
Creating awareness	rep, med	rep, med	rep, med
Creating commitment	rep, med	rep, med	rep, med
Planning consultation	comm, rep	comm, rep	comm, rep
Providing labour			
- for construction	comm	comm	(comm) ¹
- for O & M	comm	comm	(comm) ¹
Management			
- technical	app	app	-
- financial	rep	rep	rep

¹ As far as infrastructure is provided at household scale

2.6.3 Socio-cultural factors

All studies addressing sanitation in developing countries affirm the importance of social and cultural factors as "pull factors." The operational recommendation generally made is to increase the community's motivation and commitment, and to better tailor the programme to its acknowledged preferences by letting it participate in the planning, selection and possibly management stages.

Specific issues to be taken into account are:

- local customs in household affairs and social structure; religious considerations;
- the general preference for private, in-house toilet facilities, rendering public toilets for a small neighbourhood often inappropriate because unsustainable in operation,
- preference for convenience, privacy, location and aesthetic features such as colours, smells, materials used and design aspects,
- importance of local autonomy and confidence in political and technical authorities,
- experience with and willingness to undertake such initiative jointly, and in cooperation with local or central government,
- preference for the type of anal cleansing material.

It is not easy to ensure that the potential users are satisfied with the physical form in which the on-site sanitation systems come. When shared or public facilities are considered, decision making involves many, and carries the risk of fundamental disagreements with regard to financial implications (notably if linked

or not linked to income categories)

Also if off-site technology with sewerage is considered, the intended beneficiaries must be first committed to connecting to the system, as well as to proper use and paying their fees.

2.7 Financial and economic aspects

2.7.1 Overview

The financial and economic aspects of sanitation projects are similar to those of other infrastructure projects, but are often more difficult to adequately quantify. Consequently, financial and economic analysis has been less powerful in determining the viability and priority of such projects. This is important, as the role of such analysis is to provide a clear context in which decisions can be made. In order to minimize this problem, it is essential that the proponents of a project have a clear understanding of the potential and use of financial and economic analysis. This is especially the case when "new" technologies, for example anaerobic treatment, are being advocated.

There is a clear distinction between the roles of economic and financial analysis. Economic analysis looks at the proposed project from the point of view of the economy or society as a whole, while financial analysis examines the proposed project from the viewpoint of one of the organisations/actors in the project, usually only the implementing organisation.

Financial aspects of sanitation projects are operationally more important. The actual amounts of money expenditures and revenues are usually determinants of the sustainability and acceptability of a project. Capital expenditures, unless subsidized, become debt service expenditures, dependent on financing terms and conditions. Operations and maintenance (O & M) expenditures are dependent on the efficiency of O & M systems and on inflation. Revenues depend on tariffs that are affordable and acceptable, and on the ways tariff collection and inflation rates are adjusted.

2.7.2 Financial analysis

The financial analysis of a project requires the determination of actual money expenditures and revenues, financing arrangements, and prices/tariffs over time. These expenditures and revenues are set out over time in a cashflow format.

Using Cost Benefit Analysis (CBA) techniques this format allows the determination of project "profitability" and the financial "return" on the project. This process is useful for several reasons. These are:

- A comparison between projects in the same sector (for example, different types of sanitation projects) is possible, and this comparison can be extended to

compare among different sectors (water supply versus sanitation projects for example). It should be noted that financial analysis does not compare the relative benefits of the two projects to the society, but will often explain the attitudes of the implementing agency. For example, a municipality which has its capital costs for water supply subsidized, but does not have a subsidy for capital costs of sanitation, is unlikely to prefer the latter investment.

- Times of critical cashflow (when revenues and expenditures are similar) can be identified and provision made for such risks.

- The targets for such things as expenditure on wages, number of users, levels of tariff, etc., are made explicit and can be used to (i) examine the adequacy of the institutional structures which must achieve these targets, and to (ii) monitor the performance of these structures. The target levels and timing of expenditures and revenue enhancement measures (higher taxes and/or fees) depend also on political and social acceptability, and this can be better gauged when more concrete estimates of targets are available.

Where revenues are uncertain or where certain levels of outputs must be attained, Cost Effectiveness Analysis (CEA) can be employed with the same benefits as outlined above for CBA. The effectiveness of a project can be measured by comparing the cost of various projects which will achieve a given set of quantifiable outputs – not necessarily revenue. CEA establishes the least costly method of achieving a given project outcome.

Financial CEA is used in this report to measure sanitation affordability for households.

2.7.3 Economic analysis

Economic analysis tries to examine the total costs and total benefits to society over time. While costs usually can be identified and quantified, benefits in terms of public health improvement or pollution control are often less clear. One way out is to introduce "social costing" in which social benefits are quantified in economic terms. When the total costs and total benefits can be estimated in money terms over time, a Cost Benefit Analysis (CBA) can be undertaken.

When benefits are less certain, Cost Effectiveness Analysis (CEA) is used. This technique is particularly useful in comparing the various sanitation techniques, and a modified version of this technique has been used in this report. The techniques used are the Total Annual Cost per Household (TACH), and the capital cost per person equivalent (cap). These techniques determine the least cost sanitation options in terms of annualized cost and present values respectively (See Appendix 2).

Money values of costs and benefits are not necessarily the best indicator of the real costs and benefits to society. In order to overcome this problem, these money values are modified to reflect actual costs and benefits to the society, and the modification is achieved using a technique known as "shadow pricing." This technique will be discussed and applied in *Chapter 4*.

2.8 A preliminary "landscape matrix" with strategies and determinants

The different options in sanitation programmes suited for different situations create a landscape with niches in which specified sanitation systems seem to be most feasible. With the key determinants as criteria the feasibility of sanitation options can be assessed by *Table 2.8* where typical features are indicated assuming good design and proper care are guaranteed

The determinants pertain to

- technical performance and effectiveness of the technology,
- the economic and the financial feasibilities,
- the institutional feasibility, and
- the degree of community involvement that is needed or can be reached to achieve success.

In addition the choice with respect to the waste water collection part will define whether the sanitation programme will be basically on-site or off-site.

The determinants that were described in this Chapter can be applied to assess the feasibility of a treatment technology too.

From the "technical" determinants it appears that technology allows a government to develop strategies that aim at specific objectives:

- control of environmental pollution aiming at different water quality levels (namely four - see *Section 2.5.1*),
- improvement of public health, by keeping human waste containing pathogens as much as possible away from people,
- protecting or not the shallow ground water from contamination by percolating from on-site waste collection and "treatment" facilities, shallow ground water being a major source for consumption water.

In *Chapter 7* a more comprehensive matrix will be established in which strategies and determinants are further outlined, incorporating the considerations of the following Chapters.

Table 2.8 Comparative analysis of sanitation programmes (on-site, intermediate-scale, off-site) by major selection determinants. The marks indicate attraction (in terms of performance, applicability or cost) of the programme, they have only a relative meaning to allow comparison within one row

	On-site		Intermediate-scale		Off-site
	black	grey	black	grey	grey
Determinant (Strategy)					
- Technical					
- BOD removal (Environmental pollution control)	-	0	0	++	++
- Pathogen rem (Public health improvement)	0/(++) ¹	0/(++) ¹	0/+	0/+	0/+
- Process stability	+	0	+	+	++
- Economic and financial	++	0	++	+ / ++	-
- Institutional	0 / ++	0 / +	0	0	-
- Community involvement	++	++	++	++	-

¹ Provided percolation of supernatant into soil functions well, and removed sludge is disinfected

Legenda

- ++ high efficiency, easy, very low cost
- + good efficiency, relatively easy, reasonable cost
- 0 fair efficiency, not very easy, higher cost
- poor efficiency, relatively difficult, higher cost

3 Anaerobic Treatment of Domestic Waste Water

3.1 Introduction

Anaerobic digestion processes occur in many places where organic material is available and redox potential is low (zero oxygen) as in stomachs of ruminants, in marshes, sediments of lakes and ditches, municipal landfills, or even sewers.

For a long time these processes have been used by man for the stabilization of wastes and for the production of methane, a valuable source of energy. Traditional Chinese and Indian digesters, septic tanks (since 1895), Imhoff tanks (since 1905), anaerobic ponds and sludge digesters are typical examples. These traditional systems are in the context here defined as low-rate systems because they are not based on an understanding of the underlying biotechnological processes and because they require long digestion times and thus large volumes.

More recently, since the seventies, attempts to save energy and land have put emphasis on anaerobic treatment as an advanced biotechnology. High-rate reactors applying **fluidized bed**, **anaerobic filter** and **upflow anaerobic sludge blanket (UASB)** techniques have evolved and are in many instances successfully applied. These reactors can retain high concentrations of active biomass, thereby reducing required retention times. They provide an improved contact between the micro-organisms and the substrate. These reactors are most suitable for the treatment of a range of high strength industrial waste waters, especially those which are highly biodegradable. *Picture 1* shows an anaerobic reactor treating the effluent of a starch factory in the Philippines.

For several years now research has been carried out on the treatment of domestic waste water in these high-rate anaerobic reactors. Research in Brazil, Colombia, India and Indonesia demonstrated that under tropical conditions with sewage temperatures above 20 °C, anaerobic treatment may be economically feasible. In moderate climates with sewage temperatures below 20 °C, the feasibility of anaerobic treatment of domestic waste water is at the present state of the technology questionable.

3.2 Anaerobic microbiology

Anaerobic treatment involves biological processes in which organic material is degraded and biogas (composed of mainly methane and carbon dioxide) is produced. These processes take place in the absence of oxygen. Usually the anaerobic pathway of degradation of organic matter is divided into four steps (*Figure 3.1*).

1 Hydrolysis

Proteins, fats and polymers are converted to monomers by exo-enzymes of micro-organisms. This step is in most cases, notably with sewage as substrate, rate-limiting for the overall process and is very sensitive to temperature

2 Acidification

Formation of alcohols, volatile fatty acids (VFA), and carbon dioxide.

3. Acetogenesis

Formation of acetic acid, hydrogen and CO₂.

4. Methanogenesis

Formation of methane from carbon dioxide and hydrogen, and acetic acid.

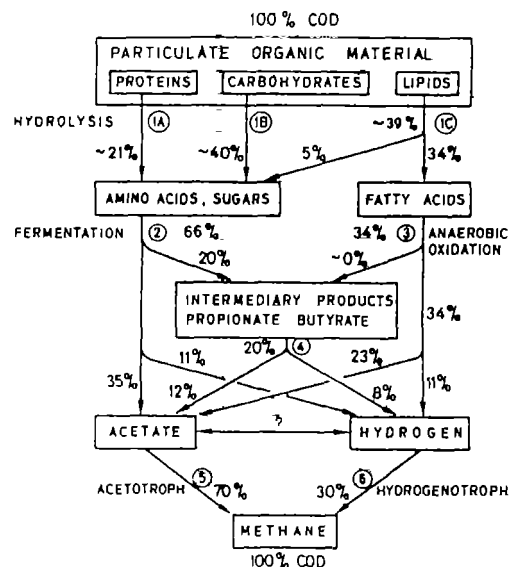

Figure 3.1 Anaerobic degradation pathways. Percentages refer to net substrate flow (degradation minus cell formation) expressed in COD equivalents (Gujer and Zehnder, 1983)

For anaerobic bacteria this process is energetically very inefficient. A large part of the energy residing in the substrate is liberated in the form of methane and therefore anaerobic bacteria grow relatively slowly compared to aerobic bacteria. At the same time this aspect is the most important feature of anaerobic degradation processes as a waste treatment process, namely:

- the energy input of the system is low, as no energy is required for oxygenation,
- the degradation of waste material leads to the production of a valuable source of energy, namely methane,
- the slow growth of the bacteria results in a low production of excess sludge,
- the slow growth of the bacteria also means a low nutrient requirement.

The employment of high-rate anaerobic reactors requires some process control, since the methanogenesis is sensitive to the pH: a low pH inhibits the process. If organic loading suddenly increases, and if sufficient chemical buffer capacity would be lacking, the acidification can speed up and lower the pH, thus stopping the methanogenesis; lower fatty acids will accumulate. The reactor may then become irreversibly disturbed and needs renewed start-up.

It is claimed by some research groups that the process stability can be enhanced by separating the acidification phase (in an "hydrolysis reactor") from the methanogenic phase in two separate reactors. The first reactor would also act as buffer basin to accommodate sudden load changes, and as early warning in case of arrival of toxic compounds in the influent. The chief advantage of this process layout would be better biotechnological control over the two separate stages and hence a more stable and reliable operation.

The risk for process instability due to acidification will be minor in the treatment of domestic waste water, as it is relatively diluted and well buffered

3.3 Anaerobic reactor types

In this Section anaerobic treatment systems that are currently used or are investigated for the treatment of human excreta or domestic waste water will be briefly discussed. The UASB reactor will be emphasized as this system is developed in The Netherlands and is currently the most often applied. The Directorate-General for International Cooperation (DGIS) has supported several studies to investigate the feasibility of its application on sewage in tropical countries

3.3.1 Low-rate applications

Well-known low-rate applications of anaerobic processes are.

Biogas digesters. In parts of Asia, especially in China, Korea, Nepal and India, small reactors are used to digest crop wastes, cow dung, piggery waste, and sometimes also human waste. The main goal of this practice is to produce fertilizer. These reactors are only applied in rural areas, and are integrated in the agricultural system, the material being a good fertilizer and pathogens free after digestion for 20-30 days.

Septic tank. The septic tank is a simple device to remove a large part of the settleable and organic matter from the black (sometimes grey) waste water from one or several households. It consists of a closed tank in which sedimentation takes place. Sludge degrades anaerobically and thickens. Usually it is applied on small scale, for up to 50 households or at public buildings such as schools and hospitals. Retention time of the liquid is in the order of 1 day. The effluent still contains a large part of the BOD and pathogens. See also *Appendix 1.1*

Imhoff tank. The Imhoff tank is a tank horizontally divided into two compartments, and meant for domestic sewage (pre-)treatment. In the upper chamber sedimentation takes place, and the sedimented solids flow through a slot in the bottom into the lower compartment, where it accumulates and is digested anaerobically. Retention time of the liquid is in the order of a few hours; sludge is removed typically every 20-30 days. Since sedimentation is the only treatment step, effluent quality is low. On the other hand little equipment is necessary, and maintenance requirements are minimal. Imhoff tanks can be useful for small communities, where a high treatment efficiency is not essential, and where continuous supervision is not available

Anaerobic ponds (lagoons). These ponds are integrated in waste water treatment systems, where anaerobic ponds, facultative ponds and possibly also maturation ponds are used in series. Effluent quality is medium. Liquid retention time is in the order of several days. Design and operation are relatively simple. See *Appendix 1.3*.

3.3.2 High-rate applications

The regularly organised international symposia on anaerobic treatment of liquid waste show the steady progress being made through research and development of high-rate anaerobic reactors (*e.g.* Switzen-

baum, 1985; Anaerobic Treatment, a Grown-up Technology, 1986; Anaerobic Digestion, 1988). Reactor types that are applied in practice

UASB-reactor. The Upflow Anaerobic Sludge Blanket process is currently applied for several high-strength industrial waste waters (for example sugar and starch industries, breweries and paper mills) In a UASB reactor the waste water flows upward through a layer of anaerobic well-settling sludge. At the top of the reactor a phase separation between gas-solids-liquid takes place (Figure 3.2). An estimated 150 reactors have been constructed for industrial effluents since the mid-seventies.

Since 1986 the system has been further developed to treat also domestic waste water. Currently several small (100-500 m³) reactors are in operation in Colombia. In Kanpur, India, a 1200 m³ UASB reactor for domestic waste water was started up in April 1989. The UASB technology has also been modified for use as an on-site technology. Two of such reactors (volume: 860 L) have been tested in Bandung, Indonesia (Figure 3.3). See also Section 3.5.

Anaerobic filter. Anaerobic filters are used in an upflow or downflow mode. The upflow type appears to have a better removal rate of suspended solids. The anaerobic filter is successfully commercialized and applied on full scale for the treatment of certain types of industrial waste water. Approximately 50 reactors have been built world-wide for industrial waste water

It is controversial whether the process is also suitable for domestic sewage, though work in India at the National Environmental Engineering Research Institute, Nagpur, suggests interesting opportunities. At the Bombay Dadar waste water treatment plant a demonstration reactor using a combined filter and upflow mode has functioned satisfactorily for a period of time with the relatively long hydraulic retention time (HRT) of 12 h (Joshi *et al.*, 1987).

Anaerobic contact process This is the anaerobic equivalent of the activated sludge process in the sense that the sludge is completely mixed with the waste water in the contact tank, and is separated in a sedimentation tank. More than 45 of these plants have been built for treatment of industrial waste water all over the world, most of them according to the patented ANAMET process.

The **fluidized bed** reactor was *ia.* developed and implemented on full scale by Gist-Brocades in Delft, The Netherlands, for its industrial waste water. Other development took place in the United States by Ecolotrol, where industrial and domestic waste water have been treated. Sanz and Fdz-Polanco (1990) report up to 70% COD removal at 15 °C at laboratory scale. So far only a few commercial scale reactors of this type have been taken into operation, all on industrial waste water. It is questionable whether this sensitive very-high-rate process will prove suitable to the diluted domestic sewage in full scale plants.

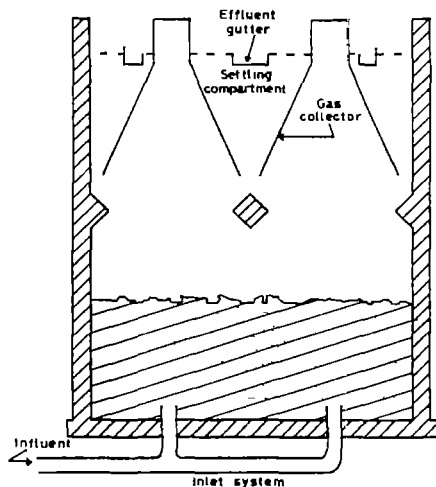

Figure 3.2 The Upflow Anaerobic Sludge Blanket reactor. The striped area represents the sludge blanket which is kept suspended by the upflowing influent. Gas is taken out via the upper part in the gas collector.

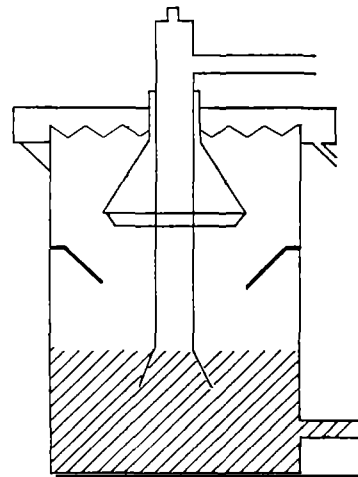

Figure 3.3 Small-scale UASB

At the University of Ghent, Belgium, Verstraete *c.s.* are developing a **Poly-urethane Parallel-plate Anaerobic Reactor**. This is an attached-film reactor featuring parallel plates made of reticulated porous poly-urethane, allowing simultaneous internal settling of settleable solids and excess detached sludge. Several modifications of the process were tested on domestic waste water. On sewage (300-1,200 mg COD/L, $T = 12-20\text{ }^{\circ}\text{C}$) fairly high treatment efficiencies of 60-70% COD removal are obtained, at the very low HRT of 1.2 hours (Verhaegen, Van Rompu and Verstraete, 1989).

Other systems that are currently being tried out for the treatment of domestic waste water on laboratory scale or pilot scale are *i.a.* **Anaerobic Attached Film Expanded Bed, Rotating Disc, Baffled Anaerobic Lagoon** (for further detail see: Henze and Harremoës, 1983, Switzenbaum, 1985).

In addition, the Agricultural University Wageningen is experimenting with modifications of the UASB process. The **Expanded Granular Sludge Bed (EGSB)** differs from the UASB mainly in the higher upward velocity, resulting in a more pronounced sludge bed expansion. The higher upward velocity can be achieved by a greater height/diameter ratio or by recirculation of effluent (de Man *et al.*, 1988). Another very recent development is the evolution of **two-step** or **three-step anaerobic reactors** with 2 or 3 reactor compartments in series. The efficiency appears higher than that of

one single reactor with the same volume (Orozco, 1988, de Man, pers. comm., 1989).

Other typical types to be mentioned are the Chinese **hydrolysis tank** and the simple UASB used in Paraná, Brazil (mentioned in Switzenbaum, 1985).

Little comparative research has been carried out on different high-rate processes. It is reported that the start-up of reactors with fixed carrier material proceeds more quickly and that these reactors are more resistant to toxic effects and shock-loading (Jovanovic *et al.*, 1986, Frostell, 1981).

A brief comparison of the major types of anaerobic reactors can be found in *Table 3.1*.

3.4 Principles of anaerobic sewage treatment processes

3.4.1 General

The purification (removal) efficiency of an anaerobic reactor can be described by using the water quality parameters, mentioned in *Chapter 2*:

- Oxygen consuming substances,
- Suspended solids,
- Nutrients,
- Pathogens.

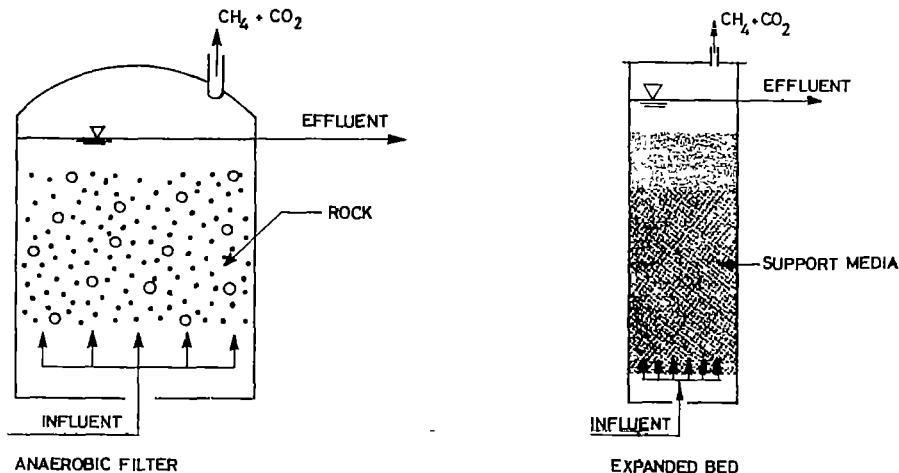

Figure 3.4 Principle of Anaerobic Filter and Expanded Bed. Two types of anaerobic reactors (Jewell, in Switzenbaum, 1985)

3.4.2 Removal of oxygen consuming substances

Table 3.2 summarizes operational characteristics and performance of only those anaerobic reactors treating sewage at the scale of pilot and demonstration plants (20 to 1,200 m³) having operated continuously for a substantial period of time (at least four months). It was attempted to add further up to date information by mailing in September 1989 questionnaires to all research and development centres that are known to investigate anaerobic waste water treatment, however, no new information could be obtained.

In this Section effluent values and treatment efficiencies are calculated on basis of raw (unfiltered) influent and effluent samples. It must be realized that part of the remaining pollution in the effluent consists of particulate matter (washed-out biological material) and that therefore short post-settling of anaerobic effluent (for typically 60 mins) can further lower the effluent concentrations of suspended solids, BOD and COD. Expressing removal efficiencies in terms of filtered effluent can thus provide an indication of the best achievable effluent quality without necessitating a more expensive micro-biological polishing.

BOD removal efficiencies of typically 65-80% (dependent on the characteristics of the waste water) can

be achieved in UASB reactors operated at temperatures of 20 °C or higher. Generally, removal efficiencies for COD are 10-20% lower than for BOD removal.

At lower sewage temperatures results are generally less encouraging. As a typical example, a pilot plant operated in Bergambacht (The Netherlands), treating colder sewage gave disappointing results (De Man and Lettinga, 1987). Figure 3.5 shows that at the temperature range 10-18 °C the BOD removal is low and determined by the influent BOD. Note that the influent at the Bergambacht site is more diluted than common sewage in The Netherlands, which has a median value of 265 mg/L and an average of 288 mg/L. The effect that removal efficiencies improve with increasing concentration appears at these low temperatures (being one reason for the noted differences in performance in the four reported periods) but is not observed at temperatures above 20 °C, like in the Cali case (see further). Low substrate concentrations exert a negative influence on efficiencies under unfavourable temperature conditions.

Table 3.1 Overview of features of the main anaerobic reactor types (Lettinga *et al.*, (1984))

Features	Upflow sludge bed reactors (UASB, "IRIS", tower reactor)	Upflow Anaerobic Filters (AF)	Downflow Anaerobic Fixed-Film system (AFF)	Anaerobic Fixed-Film Expanded-Bed (AFFEB)	Fuidized-bed systems
Rate of start-up first secondary	4-16 weeks 0-2 days	> 3-4 weeks 0-2 days	> 3-4 weeks A few days?	> 3-4 weeks A few days?	Approx 3-4 weeks Uncertain
Performance with respect to the removal and the stabilization of suspended solids (SS)	Satisfactory at low and moderate loading rates	Fairly good at low SS concn. and when the filter is not clogged	Very poor	Rather poor	Very poor
Risk of channelling	Small, unless a poor feed inlet distribution system was installed	Great at high SS concn. and in clogged filters	Small	Small	Almost non-existent
Extent of effluent recycle required	Generally not required	Generally not required	Slight	Moderate	High recycle factor generally required
Sophisticated feed inlet distribution system required	For low-strength wastes and with dense sludge beds	Presumably beneficial	Not	Necessary	Essential
Gas-Solids Separator device required	Yes, essential	Could be beneficial	Not required	Could be beneficial	Beneficial
Carrier packing required	Can be beneficial in specific cases	Essential	Essential	Essential	Essential
Height-area ratio	Can be fairly high for granular sludge beds	Moderate	Moderate	Moderate (?)	Very high

3.4.3 Removal of nutrients: Kjeldahl-nitrogen (Nkj)

As a consequence of the nature of the process, anaerobic processes are unable to remove any Kjeldahl-nitrogen by means of oxidation, but organic nitrogen is converted (further reduced) into ammonium. Therefore anaerobic systems may require aerobic nitrification as ammonium is an oxygen consuming substance (NOD). The alternative is to re-use the effluent in schemes (like irrigation) where NOD is of no major concern.

3.4.4 Removal of suspended solids

High-rate anaerobic reactors are characterized by relatively short hydraulic retention times which makes them more vulnerable to internal hydraulic or process-related disturbances causing excessive loss of suspended material. Particularly those systems that rely

on settling of suspended biomass inside the reactor, like the UASB, and systems that are designed as attached growth reactors and without any posterior settling step, like anaerobic filters, are most likely to face occasional uncontrolled washing out of suspended matter.

Table 3.2 indicates that UASB reactors are characterized by relatively poor efficiency in suspended solids removal, with values of 50-75%, as compared to 85-95% for aerobic plants. Anaerobic reactors applying hybrid configurations (UASB plus filter, or UASB plus external sedimentation) could possibly yield better results. However, full-scale experience is scarce

3.4.5 Removal of pathogens

The removal of pathogens in anaerobic treatment is extensively discussed in Chapter 5.

Table 3.2 Demonstration plant results for anaerobic sewage treatment.

	Bergambacht ¹ The Netherlands	Sao Paulo ² Brazil	Bucaramanga ³ Colombia	Calí ⁴ Colombia	Bombay ⁵ India	Kanpur ⁶ India
	UASB	UASB	UASB	UASB	Anaerobic filter/Upflow sludge bed	UASB
Reactor volume (m ³)	20	120	35	64	200	1,200
HRT (h)	8-15	4.7-9.0	5	6	12	6
Volumetric loading (kg COD/m ³ d)	0.4-0.9	-	-	2 (max)	0.7	-
T (°C)	4-18	21-25	23-27	25	-	> 20
COD/BOD	2-3.5	2	-	2-3	2.5	2.9
BOD removal (%)	24-53	61-80	80	70-90	69-83	65-70
COD removal (%)	24-54	50-70	66	50-75	49-78	62-70
TSS removal (%)	43-64	56-79	70	60-85	68	67-79
P removal (%)	-	3	-	40	-	-
N removal (%)	-	0	-	-	-	-
Effluent						
BOD (mg/L)	40-110	31-59	39	25-45	22-55	50-56
COD (mg/L)	170-303	96-132	145	120-140	92-198	91-103
TSS (mg/L)	43-80	33-61	70	30-60	117	111-165
Nkj	-	26	-	-	-	-
Pathogens/100 mL	-	10 ⁷	-	10 ⁷	-	-
Sludge prod (kg DM/kg COD _{in})	0.17-0.34	0.15-0.20		0.1 kg COD/kg COD _{in} 0.4-0.6 kg DM/kg COD _{in}	-	0.19-0.23 kg DM/m ³ 0.65-0.85 kg DM/kg COD _{rem}

¹ De Man and Lettinga (1987)

² Vieira (1988)

³ Jakma, Collazos and Schellinkhout (1987)

⁴ Haskoning (1989)

⁵ Joshi *et al* (1989)

⁶ Alaerts *et al* (1989)

3.5 Performance of UASB reactors

Well-documented research on the anaerobic treatment of domestic waste water on a pilot scale is carried out in Colombia, Brazil, India, Indonesia and The Netherlands. Five case-studies are described hereunder for which detailed and representative information could be obtained

3.5.1 UASB as on-site treatment system

In Bandung, Indonesia, the Upflow Anaerobic Sludge Blanket Project – Low Cost Sanitation Research Project aimed at studying the performance as well as the operational aspects of on-site upflow reactors for black as well as grey water. For both water types a reactor was run for considerable time, the reactors had a total volume of 860 L and a liquid volume of 800 L. One reactor (at the Biofarma site) was fed with black water only, while the other (at the Cimindi site) was fed with grey water. *Picture 2* gives a view at the Biofarma reactor during an inspection. Temperatures of the waste flows were rather constant and on average 23 °C. Both reactors were monitored intensively during

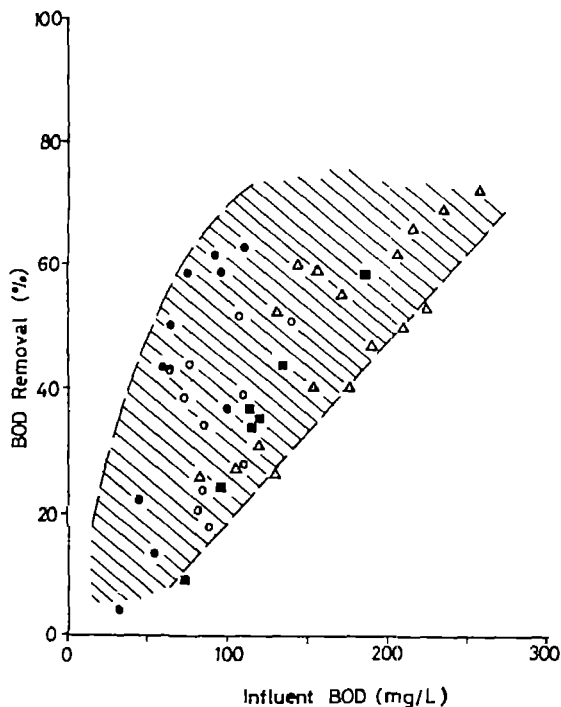

Figure 3.5 BOD removal efficiency for the cold-climate UASB pilot plant at Bergambacht, The Netherlands, during steady-state operation (de Man and Lettinga, 1987)

HRT = 8.7 h in periods ● ○ ■, and HRT = 15 h in period ▲.
All in dry-weather condition

the project, which lasted for 5 years. The project was carried out by the Agricultural University Wageningen, the St. Borromeus Hospital in Bandung, the Research Centre for Human Settlements in Bandung, the International Institute for Hydraulic and Environmental Engineering in Delft and the Dutch National Institute for Public Health and Environmental Hygiene.

a. On-site treatment of black waste water (Biofarma site)

The black waste water was collected from two households producing about 50 L/d, equal to 10 to 15 L per cap.d. The hydraulic retention time (HRT) in the reactor was around 15 days. Effluent was drained off to a nearby percolation field. The influent was characterized by a high total COD and BOD (respectively 5,500 and 1,590 mg/L)

For the start-up a small amount of septic tank sludge was added. The reactor performed fairly satisfactorily from the very beginning. Ranges of treatment efficiencies over 1986 and 1987 are given in *Table 3.3*.

Table 3.3 Treatment efficiency of black waste water in a 860 L on-site UASB in Indonesia (over 1986 and 1987)

Parameter	Range of removal efficiencies (%)
COD tot	69-81
COD filt ¹	89-95
BOD tot	86-95
TSS	93-97

¹ The subscript "filt" means efficiency is calculated as the ratio of COD in the filtered effluent over the COD in the raw influent.

Removal of indicator organisms such as faecal coliforms is very poor. Apparently the sludge blanket does not act as filtering medium. However, the sludge bed is quite effective in the removal of helminth eggs, which strongly accumulate in the sludge. Some helminth eggs (*e.g. Ascaris*) can survive for months in the sludge; this could form a serious risk for those who come in frequent contact with fresh sludge. Sludge removal and handling should therefore be carried out according to strict guidelines.

Sludge accumulated in the reactor at a rate of 0.04 kg DM (dry matter)/d which equals approximately 10 g DM/cap.d. Assuming an average sludge density of 60 g DM/L, the specific sludge volume produced per cap per day is 0.15 L. Average TSS levels in the effluent were less than 100 mg/L. The reactor could withstand the drastic fluctuations in hydraulic

and organic loads that occurred under the field conditions. When the reactor was over two thirds filled with sludge after 2.5 years of operation, the TSS content of the effluent increased during peak hours, indicating that the accumulated sludge had to be removed

b. On-site treatment of grey waste water (Cimindi site)

The grey waste water was collected from two households producing about 700 L grey water per day, equal to approximately 60-80 L/cap.d The influent to the reactor was considerably diluted with respect to COD and BOD, respectively 1,360 and 390 mg/l. Due to varying influent flow rates over a 24 h period (and significant peak flows on fridays because of religious practices) treatment efficiencies for the Cimindi reac-

tor fluctuated more widely as indicated in *Table 3.4*, which gives the ranges of removal efficiencies during 1986 and 1987

As the hydraulic retention time (HRT) was only app 1.1 day, public health performance with respect to removal of pathogens and parasites (as measured through helminth eggs) was slightly better as for conventional septic tanks. Sludge accumulation was nearly the same as for the Biofarma reactor when expressed in g DM/cap.d TSS levels in the effluent fluctuated over a wide range between 10 and 200 mg TSS/L due to varying hydraulic (shock-)loads.

For more detailed information on reactor performance, reference is made to the final project report (RIVM, AUW and St. Borromeus, 1988).

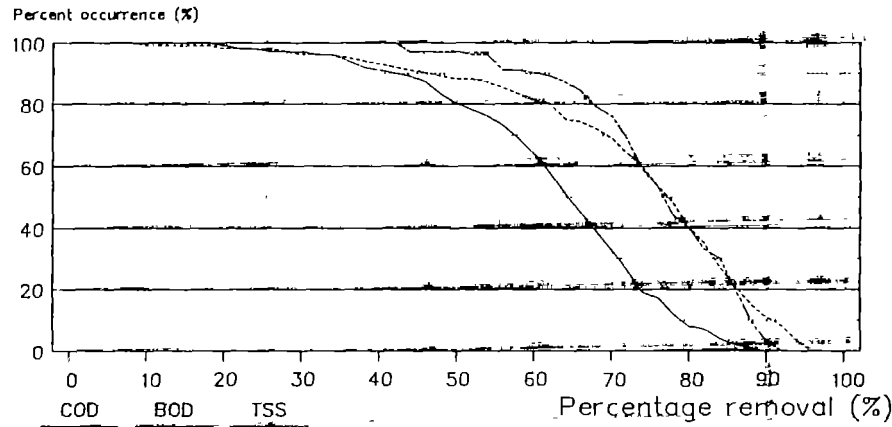

Figure 3.6 Cumulative frequency distribution of the removal efficiencies of the 64 m³ pilot plant in Cali, Colombia, during steady-state operation (Haskoning, unpublished)

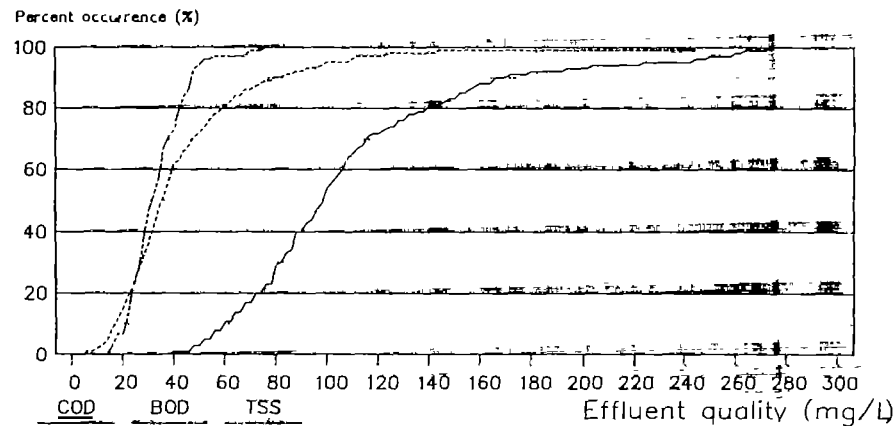

Figure 3.7 Cumulative frequency distribution of the effluent quality of the 64 m³ pilot plant in Cali

3.5.2 UASB as off-site treatment system: the Cali pilot plant research

The experiments conducted in Cali, Colombia, were monitored by Haskoning Royal Dutch Consulting Engineers and Architects (also responsible for design), the Agricultural University Wageningen and the Universidad del Valle in Cali; recently a report was published on the functioning of the UASB plant (Haskoning *et al.*, 1989). This report will soon be followed by a design, construction, operation and maintenance (DECOM) manual (Haskoning, 1989). The reactor falls under the responsibility of the Corporación Autónoma del Valle de Cauca and the Empresas Municipales de Cali. *Picture 3* shows the reactor

a. Research programme lay out

The Cali pilot plant research was carried out between 1983 and 1987. During the research programme 24 experiments were carried out. The experiments focussed on the collection of essential information on the key aspects of full-scale application, such as reactor start-up, treatment performance, gas production, sludge characteristics and production, and reactor design.

In almost all experiments sewage was used from one of the main sewers of the city of Cali: the Colector Cañaveralejo. This sewer discharges sewage which is

Table 3.4 Treatment efficiency in a 860 L on-site UASB reactor treating grey waste water in Indonesia

Parameter	Range of removal efficiencies (%)
COD tot	67-75
COD filt	22-47
BOD tot	46-82
TSS	74-81

Table 3.5 Performance of the Cali pilot plant during normal operation (HRT= 6 h)

Parameter	Effluent concen.			Removal efficiency		
	COD	BOD	TSS	COD	BOD	TSS
No of days	286	70	286	236	70	286
Average	112	34	44	65	79	76
Stand. deviat	53	11	30	-	-	-
Medlan	98	32	36	64	77	77
80-percentile	138	42	59	50	68	62
90-percentile	166	47	80	42	60	46

predominantly of domestic origin. Generally, the reactor was operated at a constant and uniform flow rate. In two experiments a day/night rhythm was simulated by applying a HRT of 4 h during day-time, and a HRT of 20 h during night-time.

Furthermore experiments were conducted to assess the reactor performance on other types of waste water. In these experiments specific contaminants such as fats and vinasses (the waste water from alcohol fermentation, with a BOD of app. 40 g/L) were added to the sewage.

The reactor was also operated with sewage of the Colector Central, another main sewer passing the pumping station where the pilot plant had been constructed. The Colector Central discharges a mixture of domestic and industrial waste water. Due to industrial discharges, extreme pH values exist in this sewage.

b. Treatment performance

In general it is of economic interest to operate treatment systems at the highest loading rate at which performance is satisfactory.

In the first phase of the study a satisfactory reactor performance was found at HRTs of 6 and 4 hours. Further research was carried out at varying retention times. It was concluded that best operational performance could be obtained at an **HRT of 6 hours** (and an upflow velocity of 0.67 m/h). At an HRT of 4 hours (upflow velocity 1.0 m/h) a somewhat increased wash-out of solids occurred though this had little consequence provided the sequence remained restricted to maximally one day. At still shorter HRTs (3 hours and less) the removal efficiency of dissolved organic material decreased, which indicated hydraulic overloading of the system.

Over the entire research period it was found that around 0.19 m³ biogas per kg removed COD was produced. The methane fraction of the gas was about 75%.

In *Table 3.5* summary statistics are given concerning the performance of the reactor during 5 experiments which cover 400 days out of a total of 1,300 days of operation on the sewer Colector Cañaveralejo. The data on median, 80- and 90-percentile were obtained from the calculation of the cumulative frequency distribution. The graphs are presented in *Figs 3.6 and 3.7*.

The effluent quality and removal efficiencies obtained during operation of Colector Central were largely comparable to those mentioned in *Table 3.5*. During the experiments the fraction of organic material in the sludge started to increase and the settling velocity of the sludge decreased, indicating too high a loading

rate. This finding could be related to decreasing biodegradability of the suspended organic material (influent from industries), a factor which apparently also plays an important role in the behaviour of a reactor.

The reactor has a large chemical buffer capacity. The reactor was submitted to alkaline shocks (pH 11-12) for periods up to several hours, yet no adverse effects could be detected. During operation of the reactor on sewage of Colector Central, these pH values occurred at least weekly for several hours.

Most of the experiments at the pilot plant were conducted at constant flow. A UASB reactor operating under field conditions will be submitted to a day/night fluctuation of the sewage flow. This implies that a reactor operating at an average HRT of 6 hours will be operating at shorter HRTs during the day-time, when the sewage flow is higher. The experimental evidence showed that at an average HRT of 6 hours (day-HRT = 4 hours, night-HRT = 20 hours), the treatment performance was better than at constant flow with HRT = 6 hours. At an average HRT of 4 hours (day-HRT = 3 hours, night-HRT = 20 hours), however, the treatment performance was poor. It was concluded that the simulated variation of the flow resulted in a regularly less expanded sludge bed, which would cause the recorded improved solids removal. In case of an average HRT of 4 hours, the day-HRT of 3 hours appeared too short to give acceptable treatment efficiencies. The reactor clearly was hydraulically overloaded.

The removal of phosphorus was found to be approx. 40%. Half of the P removal is due to uptake for the production of new cell material, the other half is due to adsorption onto the sludge. (It should be noted however that the influent was low in phosphorus) The alkalinity of sewage increases in the reactor due to the formation of bicarbonate.

The average concentrations of ammonium, total-P and alkalinity are given in *Table 3.6*.

Table 3.6 Averages of alkalinity, ammonium and total phosphorus of the influent and effluent of the Cali pilot plant

	Influent	Effluent
Alkalinity (meq/L)	2.5	2.9
NH ₄ ⁺ -N (mg/L)	10.5	14.9
P-tot (mg/L)	2.6	1.6

3.5.3 UASB as off-site treatment system: Bucaramanga, Colombia

Within the framework of activities related to the Environmental Sanitation Masterplan of the Metropolitan Area of Bucaramanga, Colombia, DHV Consulting Engineers carried out a technical assistance programme during the period 1984-1986. The reactor falls under the responsibility of the Corporación de Defensa de la Meseta de Bucaramanga.

In this programme a 34 m³ UASB reactor was tested with success. Even at a 24h-average HRT of as low as 5.2 hours effluent quality was constantly good. A day-time minimum HRT of 2.5-3 hours was common, but did not adversely affect the performance of the reactor.

The UASB reactor was followed by a facultative pond, which functioned as a secondary (post-)treatment. During the experiments, the loading of the pond was stepwise increased, resulting in a final loading of 570 kg BOD/(ha day) and an HRT for the pond of 1 day. Under this condition the total BOD removal efficiency of UASB + pond was 89%.

Based on these results, it was decided to select the UASB/facultative pond system as treatment process for Bucaramanga. Plans have been drawn up for the first phase for a treatment capacity of 80,000 cap, later to be enlarged to 160,000 cap (Jakma, Collazos and Schellinkhout, 1987). The plant will be started up in 1990.

3.5.4 UASB as off-site treatment: Kanpur, India

Within the framework of the Ganga Action Plan, an Indian-Dutch programme prevails in the treatment of waste water in anaerobic reactors of the UASB type. The plant is designed, and monitored during start-up, by Haskoning Royal Dutch Consulting Engineers and Architects. The plant is commissioned by the Ganga Project Directorate, New Delhi, and the Uttar Pradesh Jal Nigam (U.P. Water Corporation), Lucknow. In the first phase of the programme a 1,200 m³ reactor is constructed, treating part of the domestic waste water of the city of Kanpur. This reactor is by far the largest demonstration-scale anaerobic treatment reactor for domestic sewage at present. *Picture 4* gives an impression of the interior of the reactor during the construction. This plant is in operation since April 1989, and its functioning was evaluated in December 1989 by an Indian-Dutch Joint Appraisal Mission (Alaerts *et al.*, 1989).

Conclusions of this mission are primarily based on a six-week period of steady-state operation, during September/October 1989, but were confirmed over the period January-May 1990. During the other periods performance was never deviating systematically.

from this "normal" behaviour, and deviations could always be attributed to mechanical problems (blocking pumps, faulty removal of excess sludge, etc.) At a 24h-average HRT of 6 hours, the capacity of the reactor is approximately 5,000 m³/day. The sewage contains a sizeable fraction (possibly up to 5%) of industrial discharges from *ia* textile factories and tanneries. The reactor consists, for experimental purposes, of three compartments with modifications in technical aspects of design (inlet and outlet structure), resulting in a minor variation in effluent quality. The average performance of the reactor over the mentioned period is summarized in *Table 3.2*

Some of the conclusions that can be drawn from the available data are:

1. The effluent quality and treatment efficiency for BOD, COD and TSS fell marginally short of the standards that are applicable in India for discharge into surface waters of the Ganga Action Plan (*Table 3.7*), but standards for discharge on land are met except for TSS. The results can be considered representative for routine operation, and will possibly improve as there exists a scope for further optimization of design and operation procedures. Therefore post-treatment will be necessary. Post-treatment may consist of lagooning or another suitable aerobic process.
2. Sludge production is lower than that of aerobic treatment systems. However, the amount of sludge produced is higher than at the UASB reactors in Cali, Colombia or São Paulo, Brazil. This seems to be caused by the high concentrations of suspended solids in this particular influent.
3. Net Present Value of UASB including post-treatment (lagoon or activated sludge) is 15-30% lower than that of activated sludge plants or trickling filters for the same capacity, including sludge treatment.
4. Biogas production is sufficient to supply all electric energy necessary at the treatment plant for pumping purposes (15 kW).
5. The reactor is technically speaking of simple conception with limited electro-mechanical equipment. This is an advantage in areas where power cuts are frequent; aerated treatment processes would experience considerable damage. Daily operation and maintenance are relatively clear-cut, and can be taken care of by a dedicated and experienced supervisor without advanced training. However, regular monitoring by a scientist and/or engineer is necessary, especially during start-up periods. Major points of attention are (i) the cleaning of the grit removal structure, and of inlet and outlet systems, and (ii) the regular careful withdrawal of sludge. Care should be taken not to disturb the sludge blanket. The reactor appears reliable and

stable, despite frequent discontinuation of influent feeding. The reactor features on the other hand a short retention time, and thus requires intensive supervision so that swift action can be taken in the case of malfunctioning.

Some questions, however, remain to be further investigated, notably the effect of colder sewage temperatures in the winter season (ambient temperature at noon 20 °C, at night 5 °C), and the effect on the longer term of diurnal fluctuation and shocks in the hydraulic loading.

3.6 Major conclusions and recommendations

In this section, conclusions and recommendations that can be drawn from literature survey and above mentioned projects, are discussed.

a. UASB as on-site system

Regarding the application of UASB technology for on-site sanitation the following general conclusions and recommendations are justified.

1. On-site upflow systems perform fairly satisfactorily in terms of COD and BOD removal under existing field conditions in Indonesia. Variations in hydraulic and organic loading rates were well taken by the systems without disturbing the process stability. Upflow systems treating black waste water have significantly higher removal rates for COD and TSS mainly due to low hydraulic loading and consequently high retention times.
2. Upflow reactors do not effectively remove or destroy pathogens. Helminth eggs are removed fairly effectively in the black waste water reactor as they accumulate in the sludge bed; hydraulic retention times need then be sufficiently long (more than 10 days).
3. A major design parameter for on-site reactors is not the hydraulic retention time (as is the case for the UASBs on conventional sewage) but the sludge accumulation capacity. A specific sludge accumulation rate of 0.01 kg dry solids or 0.15 L/cap day can be used for reactor design. This should then allow for at least one to two years of continuous service before desludging is to be carried out. One should keep in mind that TSS removal rates drop considerably when the reactor is more than two thirds full with sludge.
4. Gas production was around 5-6 L/h in the reactor treating black water and 7-8 L/h for the reactor treating grey waste water. Generally this means a biogas production of 25 to 30 L/cap day for both reactors, regardless of the type of influent. Utilization of these small amounts of biogas does not seem feasible nor attractive.

5. On-site upflow reactors do not require frequent operation and maintenance attention provided that care is taken with what is discharged to the reactor. Bulky items may clog piping while toxic compounds may reduce the sludge activity. In case of interrupted feeding or shock condition during partial sludge removal the reactor performance re-establishes its activity almost immediately after resuming normal operation.

b. UASB as off-site system

Temperature. The experiences with the UASB system for domestic waste water allow its application at waste water temperatures over 20 °C. At lower temperatures sludge activity and removal efficiencies decrease (down to 40-60% on BOD removal at 14-16 °C). Research indicates satisfactory performance may eventually become feasible also at lower temperatures (down to 16 °C?).

Composition of the sewage. Normal domestic sewage can be treated in a UASB reactor. For COD < 1,000 mg/L the design of the reactor can be based on hydraulic retention time. The system is flexible towards higher loads of dissolved organic material. High concentrations of suspended solids (TSS) may give problems, while the active biomass becomes "diluted" with inert or not-degraded solids. Also a low bio-degradability of the suspended organic material negatively influences the sludge quality and hence the performance of the reactor.

For domestic sewage with a fraction of industrial waste water particular attention must be given to:

- fats: the presence of fats causes flotation of sludge and therefore reduced removal efficiencies of solids;
- pH: high pH values are often buffered readily by the system. Low pH values can only be allowed for a limited period (10-20 minutes);

- specific toxic components: anaerobic sludge is sensitive for a number of toxic or inhibiting compounds. Ammonia, volatile fatty acids and hydrogen sulphide are toxic only in unionized form. This means that under normal pH values high concentrations of the dissociated forms of these compounds can be present without any problem (Table 3.8). Further, adaptation of the sludge takes place, in case of shock loads, a quick recovery appears often to be possible (Koster and Runzema, 1984; Field, 1988).

Another important group of toxic compounds are heavy metals. Heavy metals are more toxic at alkaline pH. However, at such higher pH solubility decreases and precipitation with sulphide or carbonate may take place. Toxicity also depends on other environmental factors. Adaptation of the biomass to high levels of heavy metals does not occur.

Other compounds that are toxic in low concentrations are cyanide, antibiotics, detergents, chlorinated hydrocarbons, tannins and resins, aromatic compounds. For wastewater containing toxic compounds in such concentrations that possibly negative effects upon the microbiological activity may occur, pilot plant experiments should assess the feasibility of the process.

Hydraulic loading. For temperatures comparable to those in Cali (25 °C) or higher the dimensioning of the reactor is well-defined. The criteria established in Cali, Colombia were applied for a 1,200 m³ UASB reactor in Kanpur, India and were found valid. The 24h-average HRT is established at 6 hours, whereas during maximum flow (day-time) an HRT of 4 hours can be allowed. Under rain conditions (peak hydraulic loads) an HRT of minimally 3 hours can occasionally be permitted. The UASB reactor seems therefore best suited for separate sewerage systems into which no storm water is allowed.

Table 3.7 Results of 5,000 m³/day UASB in Kanpur, India, results of 6 weeks steady-state operation (later on confirmed over several months)

	Effluent			Gas recovery	
	BOD	COD	TSS	(m ³ /day)	(m ³ /kg) COD removed
Achieved (mg/L)	< 50	162	145	130	0.1
Removal efficiency (%)	60-75	65-75	65-80	-	-
Standards to be a					
Ganga Action Plan standard (to river)	30	-	50	-	-
Ganga Action Plan standard (to land)	30	-	50	-	-

Treatment efficiency. The treatment efficiencies (determined on the basis of raw, unfiltered effluent samples) that can be expected from a normally operating UASB reactor are:

COD= 65% (50 - 75%),

BOD= 80% (70 - 90%),

TSS = 75% (60 - 85%).

The pathogens removal of the system is negligible.

Operation and maintenance. The experience with large-scale UASB plants, though still limited, suggests that these plants can operate fairly well. The process stability to disturbing events is good, if the reactor is well designed. Non-documented reports on performance of plants of suspected poor design in Colombia support this statement.

Reliable and relatively fast **start-up procedures** are reported to have been developed at the Cali and Kanpur site. Start-up, or any renewed start-up, nevertheless will always take two to three months before steady-state conditions are arrived at, and requires supervision by knowledgeable staff.

If properly designed, UASB plant **supervision** is mostly restricted to routine sampling on a daily basis, observation and maintenance of the grit removal and water conveyance structures, scum removal and removal and management of excess sludge. Apart from pumping equipment and the flare (and if the biogas is used, the blowers and safety devices), electro-mechanical parts or other sophisticated instruments are scarce. Once the reactor is put into operation, it appears not to necessitate intensive high-level supervision. The main tasks of the supervisor are to prevent disturbances occurring in the reactor, and managing the sludge blanket. Both tasks are not very compli-

cated but do require skill and experience. The correct withdrawal of excess sludge has shown in Kanpur to be highly important in the larger sized reactors: though the sludge blanket is well mixed it may prove difficult to withdraw the required fraction in sufficient (and not too large) quantities without disturbing the reactor.

The short retention times require the quick response of plant supervisors to prevent serious plant disturbance or even breakdown in the case of abnormal working conditions. This may happen for example when influent characteristics (presence of inhibitory compounds, floating or fatty material, influent pump failure) negatively affect the quality of the anaerobic sludge. Of particular concern is sludge wash-out.

For **maintenance work** on the internals of a UASB, such as the sewage distribution system or its gas collectors, the reactor has to be shut off completely. In some cases the reactor has to be emptied. Maintenance, requiring emptying of the reactor, however, should not be required more often than every 10 years in a well-designed reactor. In order to avoid sludge loss and long new start-up periods in these situations, it is recommended to operate UASBs in parallel configuration.

Experience in Cali shows the need for regular **cleaning** (yearly or bi-annually) involving removal of accumulated (i) floating material from the insides of the gas collectors, and (ii) heavy settleable material (grit) from the bottom of the reactor. To facilitate the latter special heavy-sludge removal laterals on the reactor floor may still need to be developed.

Table 3.8 Toxic effects. Indicated is the level at which 50% inhibition of methanogenic activity occurs. Effective Dosis (ED50) in mg/L (Field, 1988)

Compound	ED50 (mg/L)
Free NH ₃	50
NH ₄ ⁺	1,000 (unadapted sludge) 4,500 (adapted sludge)
Free H ₂ S	250
H ₂ S (pH 6.8)	530
Free VFA: C ₂	16
C ₃	6
VFA (pH 7.4)	15,000



Picture 1 An upflow anaerobic reactor operational since 1986 in a starch factory in a remote rural area in Mindanao, The Philippines. Although located far away from the technical backing expected near cities, the reactor performs well and works reliably (Biotim Consultants)



Picture 2 Top view of the open 860 L experimental on-site anaerobic reactor in Bandung, Indonesia, treating black waste water (Bio-pharma location).

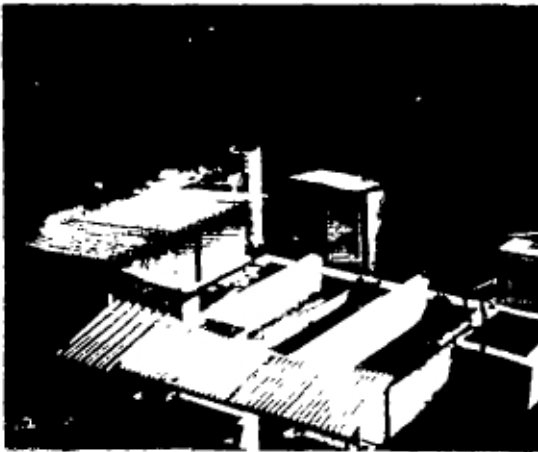

Picture 3 The 64 m² UASB pilot plant in Cali, Colombia. The anaerobic reactor was constructed and operated on municipal waste water in a joint Colombian-Dutch project.



Picture 4 Full-scale anaerobic plant under construction at Kanpur, India. The reactor is 6 m deep and constructed under ground level. This reactor is a first phase in a comprehensive plan; it will treat 5,000 m³ per day or 30,000 cap. The plant was successfully started up March 1989 by the Dutch designer (Haskoning Consultants)



Picture 5 On-site public facility for water supply and sanitation (MCK) in an area of medium population density in Bekasi, urban Jakarta, Indonesia (1984). Foreground: septic tank is drained to gutters and drainage canals, in order to protect shallow ground water from pathogen contamination. Hand pumps are used to pump shallow groundwater. The program is not fully satisfactory: acceptance by the community is sometimes problematic, and some septic tanks started leaking.



Picture 6 Open drain in Bandung, Indonesia. Beside storm water, also waste water is discharged into the drain. Note the pollution due to solid waste.

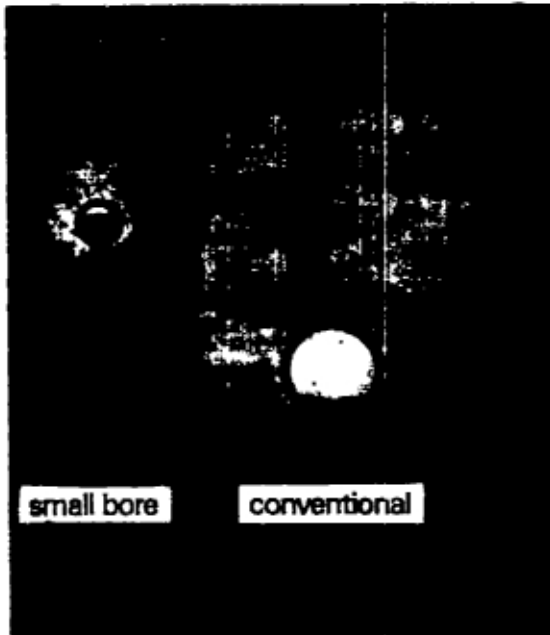

Picture 7 In this picture the difference is shown between small bore sewer and conventional sewer. The former can be laid with less effort due to its shallow position and small diameter. The conventional sewer needs a large diameter to accommodate high peak flows.



Picture 8 One of the two operational treatment plants in Indonesia under local authorities. This oxidation ditch treats effectively industrial and domestic waste water in the Rungkut Industrial Estate in Surabaya, Indonesia, since 1981.

4 Anaerobic Waste Water Treatment at On-site Scale

4.1 Introduction

Over the past decades little progress has been made in the development of the basic technology of unsewered sanitation alternatives. The design criteria for septic tanks, for example, are still very much the same as half a century ago.

The recent experience in Indonesia with upflow anaerobic reactors¹ on on-site scale (see *Section 3.5.1*), serving one to some tens of households, gives good grounds to expect that this technology may contribute to improve the efficacy of sanitation programmes in less-industrialised countries. This expectation however, is based on the treatment performance of the reactors as such, no assessment has been carried out as yet with regard to their comparative advantage in sanitation programmes.

This chapter will therefore attempt to arrive at conclusions which more accurately describe the position of this new on-site high-rate anaerobic treatment process in the "landscape" of sanitation programmes.

In order to formulate conclusions, the problem must be approached in a broad and comprehensive way. On-site sanitation must first be analysed, and its determinants, which have been discussed in a general way in *Chapter 2*, further specified

Secondly, in this setting all possible programme and treatment alternatives (at least in principle) must be assessed on their feasibility. This feasibility must be expressed in economic and financial terms, as well as in terms of acceptance by the community and any other criterion that is considered relevant. Only then can the two master questions be answered: does the new concept meet the criteria at all, and if so, is it competitive with any alternative?

¹ For the sake of simplicity, this application of the principles of high-rate anaerobic process-technology will be consistently called here UASB, because it applies in analogy with its larger-scale models the principle of active biomass suspended in an up-flowing waste water. It is acknowledged however, that on this small scale the waste water flow rate is discontinuous, and that the biomass (sludge) is only discontinuously stirred up and suspended in highly variable upflow velocities.

4.2 Approach of the study

Given the fact that the concept of high-rate anaerobic treatment (of liquid waste) necessitates the dilution by the water that is used for flushing the toilet, this comparative study restricts itself to the so-called wet processes (see *Section 2.2.1*). Based on the previous discussions regarding the determinants for on-site sanitation programmes and related treatment, and the prospects created by the on-site UASBs, this study distinguishes a number of options, discussed below.

4.2.1 Treatment

With regard to the treatment (*i.e.* removal of constituents of the waste water):

- treatment in conventional horizontal or vertical **septic tanks and lined pits**; in most cases in developing countries the septic tank accepts only black waste water, with the sullage drained in surface drains towards a receiving water body or "disappearing" into the ground,
- treatment in conventional **leaching pits**, whereby the black waste water is collected in a hole in the ground, the liquid percolating through the walls into the soil, and the remaining relatively dry sludge digesting in the hole, the sullage is drained into surface drains, or left to "disappear"; retention time of the sludge in the hole is one to a few years, leading to partial composting of the solids and consequently killing off of all types of pathogens, provided the sludge has not come into contact with fresh contaminated waste,
- ditto as above, but with a second **twin leaching pit** accepting the black waste water when the first pit has been filled, whilst the second pit is getting filled over the months, the content of the first pit is left to full composting, yet, there is some evidence that pathogens from the "wet" second pit contaminate the first pit which may then be incorrectly considered pathogen-free;
- anaerobic treatment in the **UASB treating black waste water**, sullage drained away;
- anaerobic treatment in the **UASB treating grey waste water**

All of these options necessitate the regular removal of **sludge** (once every 1-4 years) usually by a specialised

cartage company. Sludge from upflow reactors and septic tanks is always contaminated to some extent with pathogens and requires careful handling and final centralised treatment (stabilization or composting) before it can be applied in any resource reutilization scheme.

4.2.2 Effluent disposal

Secondly, alternatives are considered with respect to the way the effluent disposal of the UASB and the septic tank is organised.

This can be carried out by either letting it **percolate** into the soil through an infiltration trench or infiltration mound (made of grit and sand), or by allowing it to be **drained** via an overflow into regular street drains or, if available, sewers.

Application of the percolation leads to an effluent disposal method which in principle is convenient, fairly cheap, reliable, and effective in removing pathogens from the direct habitat. The major economic advantage of percolation systems lies in the absence of a waste water collection and conveyance network. Three drawbacks, however, need to be taken into account.

Firstly, to avoid contamination with pathogens, a minimum distance must be kept between the infiltration point and any shallow well providing drinking water. This is difficult if not impossible in more densely populated areas (population density above 150 cap/ha); this restriction has particular weight when the population heavily relies on shallow ground water, a common situation in many tropical developing countries.

Secondly, if the soil has too low a percolation capacity, or if the ground water table lies too close to the soil surface, infiltration becomes less feasible.

Thirdly, studies on the failure of septic tanks in developing countries have shown that irregular emptying of the tanks leads to irreversible clogging of the infiltration bed: rather than renewing the bed, most owners by-pass it and divert the tank's effluent to surface drains. Such habits are widespread in Indonesia (Macoun, 1988) and The Philippines (Dept. Public Works and Highways, 1987), they are reported to occur to a considerable extent in Brazil, Thailand, India, Yemen and even European countries, and should therefore be considered rather common. Conventional engineering practice insufficiently recognizes this deviant behaviour.

The alternative of draining the effluent via street gutters and drains implies a public health risk in the sense that people, especially children, may come into direct contact with waste water which is pathogenic. The drained water eventually ends up in a river or lake,

which, because of the dilution effect, may visually appear acceptable to people wanting to use it for household purposes, but which may still be contaminated to a certain degree.

4.2.3 Scale of the facility

In areas where population density is very low, say below 100 cap/ha, economic optimization would provide a household with one individual facility given the high cost of connecting piping. When population density increases, it may be worthwhile to investigate whether it is advantageous to connect several households to one facility. One may expect an economic advantage because of the economy of scale, but there may be other benefits (as well as disadvantages) with regard to supervision and maintenance. All mentioned treatment options in principle allow for this scaling-up, but particularly UASBs may prove to gain process-wise from the increased and less peaking flow which goes with the combination of the waste from several households.

When only a few households are connected to one facility, it is called here a **"shared"** facility, when the number raises to 10-100, it is called a **"communal"** facility.

The difference in terminology has little to do with technical characteristics, but emphasizes that the perception of the owner is different: if somebody owns his individual tank, or shares it with some of his neighbours, he feels a sense of ownership and personal responsibility; if on the contrary he shares it with many other families, his personal commitment will be lower, but on the other hand he may be more willing to pay monthly a small amount of money to a third person who is appointed by the community to take regular care of the installation.

Therefore, this investigation will include on-site sanitation programmes with (i) individual facilities, (ii) shared facilities to which several (5-10) houses are connected, as well as (iii) communal facilities which serve a small neighbourhood (10-100 households). Not included are the traditional separate **public** facilities (like the Mandi-Cuci-Kakus or MCK in Indonesia, see *Picture 5*) used by a number of families but without house connection; obviously their costs per capita are, at least in straightforward calculation and with the optimistic assumption of full acceptance, lower than any alternative. In certain cultures, like the Chinese, public facilities are generally accepted; in many others this is not the case.

4.2.4 Developing a case study

It is obvious that studying this complex comparison problem needs rationalization and simplification.

Therefore the study is carried out on a representative case.

The feasibilities of different on-site sanitation programmes, including those that incorporate anaerobic treatment options, are studied by simulating the representative alternatives in a number of given situations. These situations, too, must be representative for the majority of cases (urban settings) as they are met in a range of developing countries. Despite the impossibility of covering all imaginable situations, it is thought that an approach can be developed that yields conclusions with sufficiently broad validity. This approach is characterized as follows:

- It is assumed that construction and operational considerations, and costs related to small-scale sanitation depend primarily on rather trivial aspects, like the unit costs of unskilled labour, cheap piping, concrete, desludging carts, etc. From one developing country to another these unit costs, and the required quantities, will not differ so systematically that the cost position of one option relative to that of others will be fundamentally altered. Therefore it is possible to restrict the study to one carefully selected country, and add a sensitivity assessment.
- The main determinants that influence choices, and the related costs, are more or less comparable in all countries concerned. These determinants have been discussed in *Chapter 2*.

As a case study, sanitation in the setting of **Indonesian kampungs** (urban lower- and middle-class townships) is chosen, because they were considered well representative, because sufficient detailed information was available and because the pilot on-site project with small anaerobic upflow reactors was conducted in Bandung, Indonesia (RIVM, AUW and St. Borromeus, 1988; IHE, AUW and St. Borromeus, 1989).

Comparison with the urbanisation patterns in a number of other selected countries on different continents showed that the basic characteristics are population density and the degree of planning in the urbanisation of the township. *Figures 4.1* and *4.2* show the outlay of a typical unplanned kampung at low population density, and one at high population density. For the purpose of comparison, *Figure 4.3* shows the map for a **favela** in Brazil characterized by unplanned approach and high population density. Township maps from African countries, as well as maps from Indian city quarters and Philippine **barangays** can also be basically defined by the same parameters.

This study further differs in two respects from others that compare sanitation alternatives.

- It approaches sanitation as a “township-wide sani-

tion” problem instead of a single house waste discharge problem, because in an urbanised setting the per capita costs and the technical feasibilities of the alternatives depend considerably on population density and urbanisation pattern.

- It includes “treatment” with respect to BOD and to a lesser extent pathogens, rather than looking at mere removal of the waste water, as is the case with studies that focus *e.g.* on the advantages of shallow and small-bore sewers. Treatment here means avoiding pollution of surface and ground water, as well as attempting to minimize loss of environmental and public health.

Finally, it should be understood that this study centres around the question of whether anaerobic technology is feasible as **treatment** technology. The study of the feasibility of the equally important waste water collection and conveyance system is related to this but falls partly beyond this study’s scope. The design and costing basis for the anaerobic reactors refers to the still limited information from the two Bandung reactors, and needs to be further optimized.

4.3 On-site sanitation simulation study (the case of the Indonesian kampung)

4.3.1 General approach

Three **cases** represent different sets of technical aspects pertaining to ground water table and soil permeability. These sets are applied to urban patterns, which differ in terms of their **planned** or **unplanned** layout, and their **population density**.

In each of these situations it is assumed that no sanitation existed beforehand; of course, in practice this is not completely true, and each sanitation programme will in fact include a mix of old, renovated and new infrastructure. Also, it is assumed that in each calculation only one type of new sanitation infrastructure will be provided. Despite the fact that both assumptions are not completely realistic, deviations do not devalue the conclusions.

For the simulations realistic unit costs are applied, as they were applicable in urban areas in the Javanese provinces at the end of 1987. These unit costs have not changed fundamentally since then.

The **economic cost** is calculated as a Total Annual Cost per Household (hh) TACH (see *Appendix 2*). It includes all costs related to the provision of the new situation, all laterals and drains as well as the in-house infrastructure of the toilet facility (squatting slab, connection). Also the costs for breaking up and repairing footpaths and other existing structures in the kampung are taken into account. A reasonable estimate for the related water consumption and desludg-

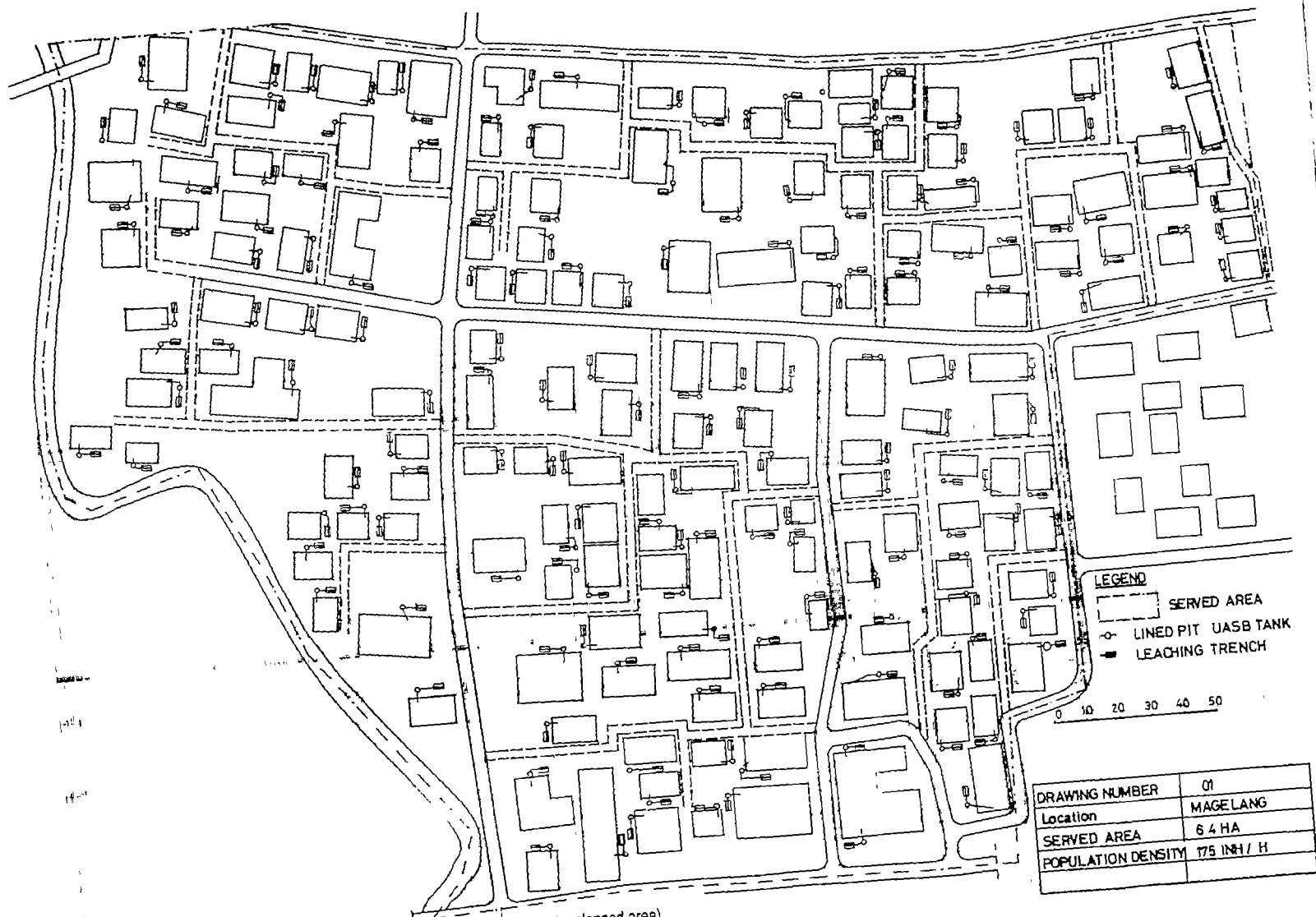

Figure 4.1 Layout of typical kampung area (Indonesia) (low population density, planned area)

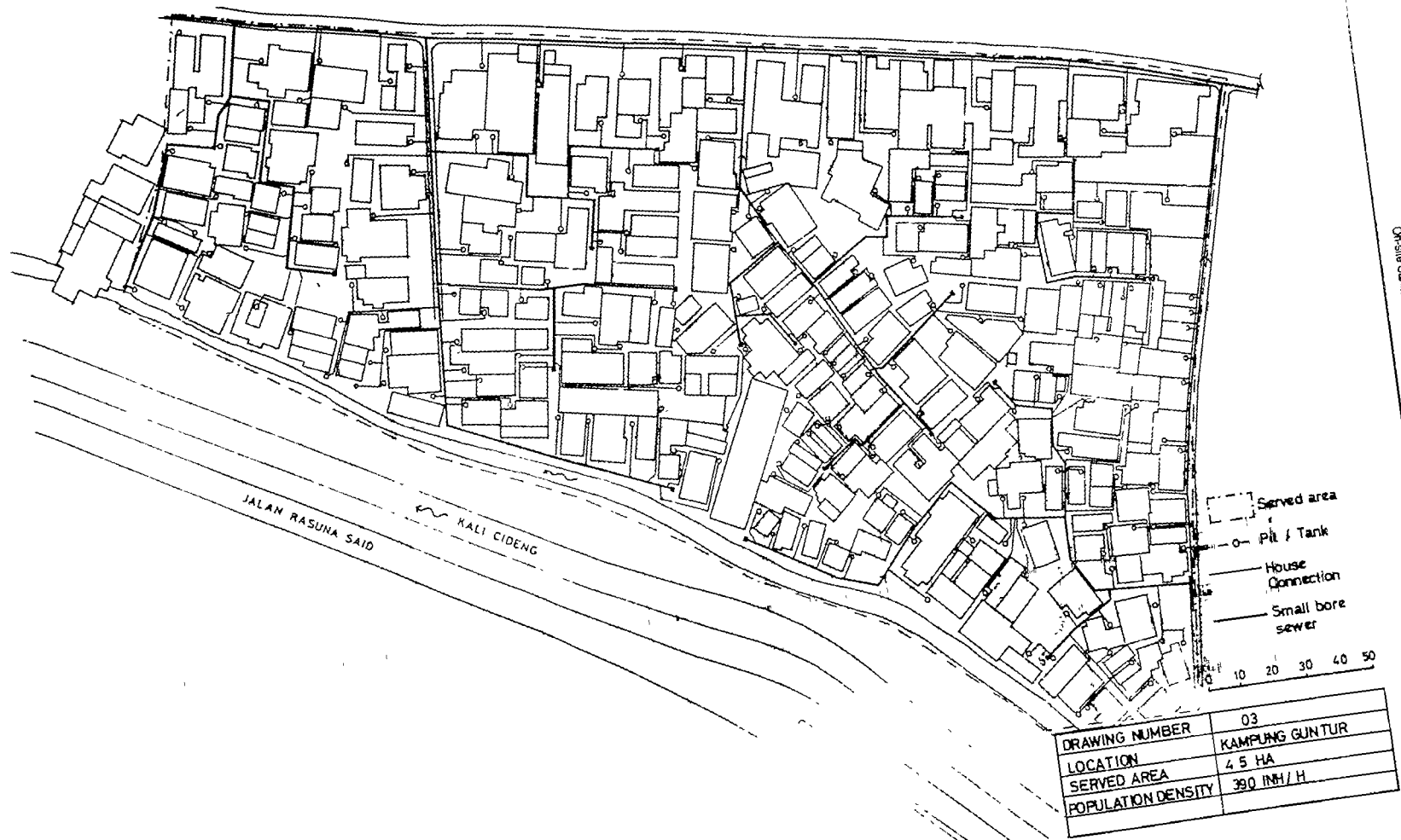

Figure 4.2 Layout of typical kampung area (Indonesia) (high population density, unplanned area)



Figure 4.3 Layout of favela area (Brazil)

ing cost is included. Costs that are very difficult to assess with precision are not included however; this pertains to, for example, the costs for the off-site treatment and disposal of sludge, as well as the (opportunity) cost of land under or on which sanitation infrastructure is located.

In the case of the alternatives where overflowing waste water is drained or sewerred, only the costs incurred inside the kampung are considered, as the principle of the calculation is "township-centred." It is assumed that the drain or sewer connects to a trunk drain or sewer outside the served area.

A labour shadow cost factor of 0.7 and an economic discount rate of 12% are used, reflecting realistic values for economic costing.

Once the least Total Annual Cost per Household (TACH) is determined, the financial cost (applying some financing alternatives) is checked to assess **affordability**. The alternatives involve a non-monetary contribution via community participation.

4.3.2 Technical description

a. Urban pattern and population density

The areas are chosen from aerial photographic and housing scheme maps. The six models selected are three unplanned areas in Jakarta, one in Magelang and two planned areas in Klender (Perumnas), also in Jakarta. "Planned" means a settlement or neighbourhood developed on the basis of an urbanisation plan, in contrast to the irregular, "wild" development of most squatter areas. By estimating the average number of people per household at seven, the population density for each model is obtained. Population density thus varies from 175 cap/ha to 804 cap/ha.

Two samples are provided in *Figures 4.1* and *4.2*, the first showing a sparsely populated area of 6.4 ha in Magelang (175 cap/ha) to be served with individual UASBs or lined pits connected to a leaching trench, whilst the second shows an unplanned densely populated kampung of 4.5 ha (390 cap/ha) to be served by individual UASBs or lined pits connected to shallow or small-bore sewer. In the latter case leaching trenches can clearly not be accommodated in the open spaces between the dwellings; pits or tanks on the other hand could possibly be located underneath housing.

b. Technology alternatives

It will be assumed that only black waste water is treated on-site; sullage water is drained on the surface. Fourteen sanitation combinations are considered, other combinations can be deduced from interpolating costs:

- (1) single leaching pit,
- (2) double leaching pit (two alternating pits),
- (3) lined pit (with open bottom) with overflow to

- open surface drain,
- (4) lined pit (with open bottom) with overflow to shallow sewer,
- (5) septic tank with leaching trench,
- (6) septic tank with overflow to open drain,
- (7) shared septic tank with leaching trench (for few households),
- (8) septic tank with overflow to shallow sewer,
- (9) UASB with leaching trench,
- (10) UASB with overflow to shallow sewer,
- (11) shared UASB with leaching trench (for few households),
- (12) communal UASB with overflow to shallow sewer (for 20-50 households),
- (13) communal septic tank with overflow to shallow sewer (for 20-50 households),
- (14) conventional sewerage (city-wide, but without treatment).

All design parameters are selected on the basis of proven procedures and good engineering practices (see for detail. Awananto, 1989). Septic tanks and UASBs are designed on hydraulic retention time if flow rate is low, and on sludge accumulation rate if flow rate is high. UASBs are more efficiently designed as reactors and it is therefore logical that they consume less space than septic tanks. It is acknowledged nevertheless that in the present state, with still limited study on optimal design, it is difficult to calculate a fair cost. This cost is based on an improved version of the field tested reactor in Bandung (see *Section 3.5.1*).

In densely populated unplanned areas space is often so restrained that it is physically impossible to construct and/or maintain specific on-site facilities. In such cases this specific type will not be further envisaged.

Rain water drains are not considered; if sullage is to be conveyed to outside the kampung, it is thought that it can be removed along these drains. However, if reactor effluents containing pathogens are to be removed by a way other than leaching, the cost of suitable open or closed drains or sewers is included.

These alternatives will be compared in a qualitative way with other possibilities, e.g. on-site treatment of grey waste water in a UASB.

c. Sewers and drains

The **drain** can be a storm drain or small ditch at the side of a footpath (*Picture 6*). Sometimes the drain is covered with concrete slabs. Like the drain, the **small-bore sewer** should receive only the effluent of on-site systems and sullage, without clogging (large or settleable) materials. Pipe diameter is 100 or 150 mm with

a. Desludging optimization

For a septic tank, the Net Present Value (NPV) of desludging (recurrent) cost lowers asymptotically with increasing desludging design period. The NPV of the construction cost increases almost linearly. The total NPV is minimal at 3 (say, 2.5 to 3.5) year desludging frequency. If a leaching pit is considered, optimal desludging frequency is 4 to 5 year.

The above conclusions depend on the discount rate applied. With rates increasing from 8 to 12% the conclusions tend to shift to a somewhat lower frequency, but in general the influence is only marginal. Generally, for leaching pits and lined pits periods tend to be unexpectedly long (4-5 years); for septic tanks and UASBs they are shorter, with 2-3 years, whilst for shared facilities desludging should take place more often (once a year). *Table 4.1* synthesizes this information.

These results, as well as those for the other options, are inserted in the calculation model.

Despite the lower cost, households may object to frequent desludging. On the other hand if desludging becomes too infrequent, a household may "forget" about the necessity of performing this duty.

b. Total Annual Cost per Household (TACH) comparison

The TACH values are the basis for the comparative analysis of the different options. TACH will be split into its major investment components (i) pour-flush toilet, (ii) pit or tank, (iii) sewer or drain, (iv) leaching system; in addition (v) O & M costs related to water use, desludging and repair are considered. *Figures 4.4a to 4.4d* show the TACH values for 4 representative situations

For a case 1 situation (low water table, high soil permeability) with population density of 175 cap/ha (unplanned area) single and double **leaching pits** doubtlessly are characterized by the least TACH (*Figure 4.4a*). Double leaching pits are marginally cheaper than single pits. Their typical TACH is app Rp 31,000/hh. Systems like **septic tank and UASB with a leaching trench** are almost twice as expensive (Rp 52,000-58,000). If the ground water needs to be safeguarded from pathogens, and these tanks or reactors are to be connected to an **open drain or shallow/small-bore sewer**, TACH increases further to around Rp 70,000. UASB reactors are 8-10% cheaper than septic tank options. **Shared facilities** are by Rp 5,000 (8-10%) cheaper than individual units, with UASBs and septic tanks connected to leaching trenches TACH is around Rp 50,000. It is clear that the additional piping cost

does not override the gain on tank cost due to economy of scale, despite the relatively large distances to be covered in between dwellings

The share in the total of the cost components may differ considerably. Construction cost of septic tank and UASB take up one third of TACH (Rp 25,000-30,000) in the case of individual facilities, but this is drastically lower (Rp 10,000-12,000) in the case of shared facilities. If a drain or sewer network needs to be constructed, approx Rp 10,000 is required, which forms one fifth of the TACH. A trench costs less than Rp 5,000. In the case of the cheaper pits, pit construction cost takes up one half to two thirds of TACH. Desludging cost is considerable, except in the double leaching pit, and it may vary from Rp 4,000 to 7,000. The in-house expenditure must be constant and amounts to almost Rp 7,000, a fourth to an eighth of TACH.

Communal facilities were not included: the long distances from dwellings to the facility would render cheap sewer systems technically unfeasible.

For the same soil and water table condition but very high population density (804 cap/ha), the number of technically feasible options is much lower because of the restrained space (*Figure 4.4b*). A single leaching pit can still be provided if it can be constructed under the dwelling (e.g. under the kitchen). Systems which involve a separate leaching trench, or a double leaching pit, can no longer be accommodated. Tank overflows need to be collected via open drains or shallow sewers. Cost ranges are only slightly higher than in the previous case. Again, as a consequence of the restricted space, it becomes technically difficult to provide sufficiently sloping sewer pipes to convey the black waste water from the house to a shared facility; these are therefore not considered.

Communal facilities were not included as no space appeared to be cheaply available for constructing them, and the crowdedness of the area made it technically unfeasible to lay cheap straight sewerage from the dwellings to the facility.

Figure 4.4c gives the TACH for the same case 1 but in a **planned** area with high population density (514 cap/ha). Leaching pits have similar TACH as earlier (around Rp 30,000). If ground water needs to be safeguarded from pathogens, costs are markedly higher because of the kampung-wide drainage or sewerage. Lined pits with overflow to drain or shallow sewer cost around Rp 40,000. Individual UASB and septic tank with overflow to drain or sewer cost around Rp 60,000, the UASB being approx 8% cheaper (15% on construction cost), they are only Rp 2,000 to 4,000 cheaper than in the case of an unplanned area where laying of piping and drains is cumbersome. In planned areas it is easier to work on the pipe-laying, but distances may

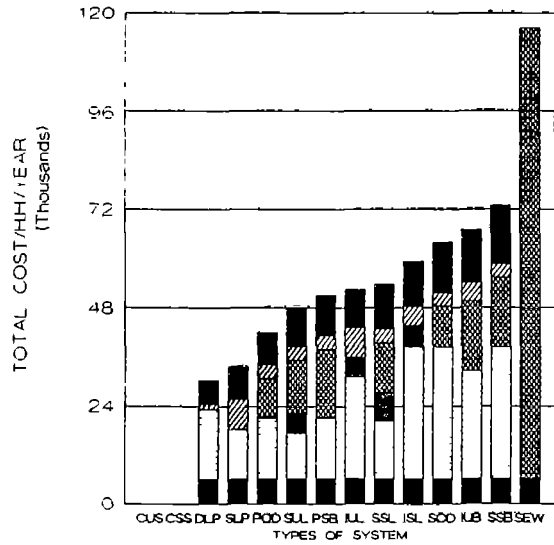

Figure 4.4a TACH values (in Rp 1,000) for sanitation options for unplanned low population density, kampung areas (175 cap/ha) Conditions, case 1.

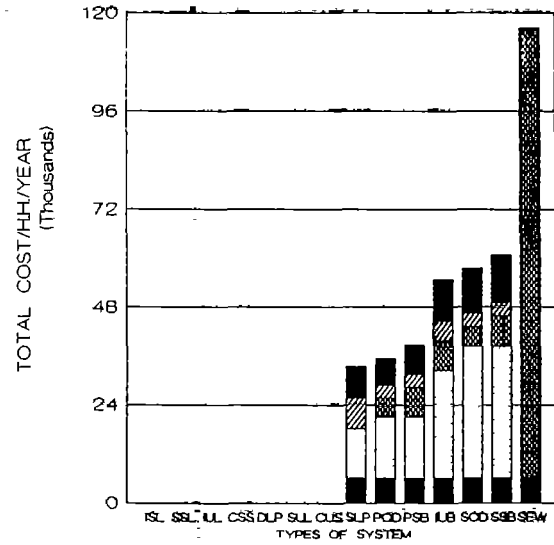

Figure 4.4b TACH values (in Rp 1,000) for sanitation options for unplanned, high population density kampung area (804 cap/ha) Conditions case 1.

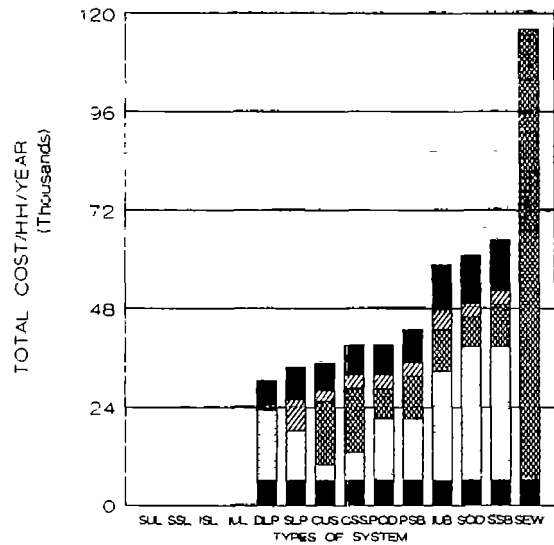
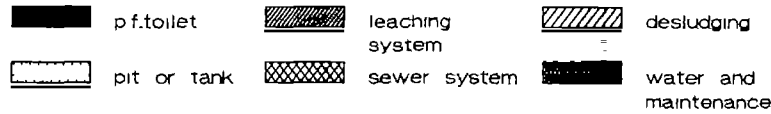

Figure 4.4c TACH values (in Rp 1,000) for sanitation options for planned low population density, kampung areas (514 cap/ha). Conditions, case 1.

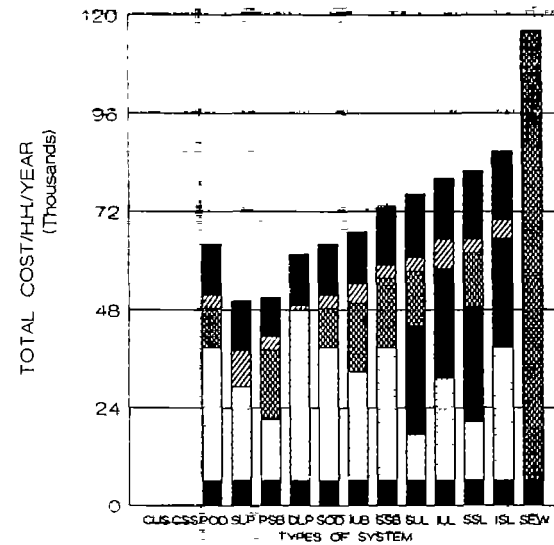

Figure 4.4d TACH values (in Rp 1,000) for sanitation options for unplanned, low population density kampung area (175 cap/ha) Conditions case 2.

become longer.

The cost structure of the communal options shows tank costs of only 10% (Rp 3,000 to 5,000) of tank cost in an individual option. Only options with overflow to shallow sewer are considered. The sewer connections from the dwellings to the facility make up for almost half of TACH.

Finally, *Figure 4.4d* depicts the case for an unplanned area with population density of 175 cap/ha (like the first example), but now for **case 2** condition (most **difficult percolation conditions**). The TACH of all options lies at least Rp 10,000 higher than under the most beneficial circumstances of case 1. TACH of single leaching pit is Rp 50,000 and that of the double leaching pit even above Rp 60,000. Contrary to case 1 conditions, all options using leaching trenches are by Rp 10,000 more expensive than those using drains or shallow sewers to remove effluents.

As a general rule, the cost related to overflow removal with an open drain lies Rp 5,000 to 10,000 lower than with a shallow sewer, this means 8-10% of the TACH.

An indicative construction price for **full sewerage**, including the provision of trunk sewers outside the kampung, is provided based on an estimate cited by de Kruijff (1985a). It should be noted that this estimate relies on simplified assumptions that are not necessarily fully compatible with those of this study. It is certainly correct to say that for 1988 conditions the given figure is an underestimate of the actual cost. On the other hand one should also realize that the highest cost component is made up by the laterals necessary

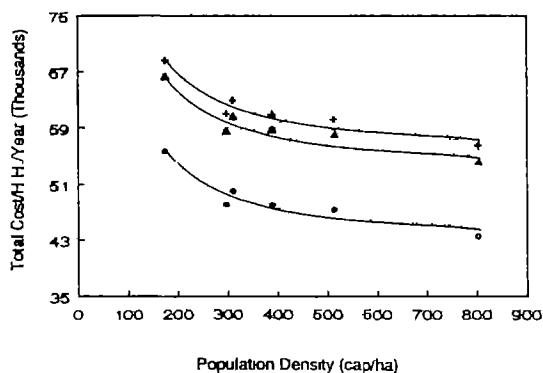

Figure 4.5 Relation between TACH for shallow-sewered sanitation options and population density. In the calculation, optimal use is made of shared and communal facilities. Treatment option (▲) septic tank with shallow sewer, (◻) UASB with shallow sewer, (●) lined pit with shallow sewer.

for the sewage collection, inevitably this will lead to higher specific sewer cost in unplanned "difficult" areas than in planned ones. The graphs indicate in any case that except for the high ground water condition (*Figure 4.4c*) this sewerage option is at least twice as expensive as the (construction cost) of the most expensive on-site alternative

c. Specific relations

The specific cost of a kampung-wide sewerage system can be expected to become lower with increasing population density because of reducing distances; the question is, however, in how far the corresponding increase in complexity and crowdedness of the area overrides this effect. *Figure 4.5* describes how the construction part of TACH for septic tank, UASB and lined pit with overflow to shallow sewer (under case 1 conditions) depends on the kampung's population density. It appears that the cost per household is reduced unexpectedly slowly for densities of ≥ 300 cap/ha, under this value a small increase in density leads to considerable benefits. Despite rapid decrease of the specific cost for the tank part with increasing population density, increasing sewer cost partially compensates for this decrease. A septic tank option is always 12% more expensive than a UASB, whilst the simple lined pit is some 30% cheaper in construction

If a selection is made for a technology that has to remove internally ("treat") as much as possible BOD, then septic tank and UASB are close competitors. *Table 4.2* highlights the main conclusions for both options in function of population density and applied scheme: individual or shared option, and in a communal option. As said earlier, UASBs are generally cheaper; this effect is pronounced in the case of communal systems. It is also interesting to note that the cost is drastically reduced by 50% or more when shared and communal facilities are proposed.

The higher the population density, the more households can share one facility. For a population density of 200, 300 and 400 cap/ha, the optimal number of "connectable" households is 5, 7 and 9 resp. Above 400 cap/ha, shared facilities can no longer serve more than 50-70% of the total population, in the kampung condition.

The higher the population density, the more households can be connected to a communal facility. For densities of 300-500 cap/ha up to 100% coverage is possible; above 500, coverage will decrease. Number of households per facility varies from 40 at population density of 400 in an unplanned area, to even 110 at population density of 500 in a planned area. These

Table 4.2 TACH for septic tank and UASB options in different schemes. Cost excludes connections and effluent disposal.

System	Size (households)	UASB (Rp/hh.yr)	Septic tank (Rp/hh.yr)	Waste water type
Individual	1	25,148	32,440	black
Shared	5-10	11,256	14,265	black
Communal	20-40	5,525	9,911	grey
	80-110	4,135	7,600	grey

Table 4.3 Financial characteristics of 5 sanitation options. All costs are annual financial or "market" costs, including investment and O & M costs.

System	Construction (Rp)	Possibilities for self-help				
		Structure	%	Construction	%	% ¹
Single leaching pit	156,650	PF toilet ²	33	unskilled labour	14	47
Double leaching pit	198,300	PF toilet	25	unskilled labour	16	41
Lined pit with open drain	263,600	house conn PF toilet	35-40	unskilled lab. for pit	12	47-52
Shared UASB with leaching trench	314,000	PF toilet	17-20	unskilled lab. for pit	8	23-28
Communal UASB with shallow sewer	253,650	grit trap PF toilet house conn	57	-	0	57

¹ Of total² PF = pour-flush toilet

System	Monthly payment ¹					
	10 year		15 year		20 year	
	Min ²	Max	Min	Max	Min	Max
Single leaching pit	1,200	1,450	1,050	1,250	950	1,150
Double leaching pit	1,600	1,950	1,350	1,650	1,300	1,550
Lined pit with open drain	2,150	2,500	1,850	2,100	1,750	2,000
Shared UASB with leaching trench	3,250	3,550	2,800	3,000	2,650	2,900
Communal UASB with shallow sewer	1,750	1,750	1,550	1,550	1,450	1,450

¹ In the first year. In subsequent years this payment must be adjusted for inflation.² "Min" - minimum payment in case of maximum ratio of self-help, "Max" - maximum payment in case of limited self-help

figures pertain to flat horizontal terrains; on sloping terrains they may be even higher

4.3.4 Financial and institutional aspects

a. Possibility of community participation (self-help)

Community participation should be considered a means to better plan infrastructure, to reduce the monetary cost to the consumers by exchanging their monetary contribution for labour, and to assist in operating a local institution that takes care of technical and financial management.

Self-help can contribute to construction and maintenance of on-site sanitation schemes. For the case of an individual septic tank with overflow to a shallow sewer system, 14.6% of the total construction cost involved (Rp 50,000-60,000) consists of unskilled labour, that can be provided to lower the financial cost. For other options similar figures are found, but leaching pits offer the best perspectives.

In terms of operation and maintenance, the potential of self-help of the community in the total expenditure is less easy to assess with precision. Desludging, as well as more specific maintenance (masonry, pipe connection repair, etc.) are to be considered skilled labour. However, part of regular maintenance (cleaning and de-clogging) of sewers and drains can be carried out by the community.

b. Financial considerations

Fifteen financial cash-flow alternatives have been developed. For five sanitation systems selected on the basis of systematic good scores in the TACH assessment, the results are synthesized in Table 4.3. In this approach the possibility of self-help is also included. The Table assumes further that a loan is made available at a cheap rate (10%, a realistic value for socially relevant loans in Indonesia) and that a 10% down-payment is required (this is a relatively "hard" requirement).

From the cash-flow analysis the minimum monthly payment is deduced, which is required to cover all expenditures at the given moments. This is done by a trial and error procedure introducing varying monthly payments in the spreadsheet programme until the cashflow fits. From the 5 alternatives that systematically score with the lowest TACH, the single leaching pit is financially most attractive. The double leaching pit and the communal UASB offer a service at a competitive price (in terms of monthly payment) which is about 20% higher.

From the financial point of view and within our set of assumptions, only these systems are financially affordable; additional preconditions are possibility for

cross-subsidization, low interest loans (maximally 10% interest rate), optimal community participation and good institutional organisation within the community and local government.

A realistic income distribution for an urban context in Indonesia is given in Table 4.4. Focusing on monthly income strata of Rp 60,000-70,000 (i.e. thus covering three quarters of the total urban population, and presumably half of the "kampung dwellers"), and assuming cross-subsidization from higher income strata to lower income strata, an affordable payment can be estimated to be Rp 1,200-1,800 (i.e. 2-3% of income). From Table 4.3 it appears that the **single and double leaching pit, and the communal UASB are then to be considered affordable**. The leaching pit is more appropriate for lower density areas, and provided percolation is smooth, whilst the communal UASB is better suited for higher density areas, particularly if effluent percolation is either difficult or unwanted (protection of shallow wells).

Table 4.4 Typical monthly income distribution in Indonesian urban areas, according to two surveys (in Rp) (IHE, AUW and St. Borromeus, 1989)

Percentile earning less than	Surabaya, Solo, Semarang 1986 results adjusted for 1988	Bandung 1987 results
15%	45,000	-
25%	60,000	-
35%	80,000	60,000
50%	120,000	-
70%	180,000	200,000

The financial data that are generated are, clearly, dependent on variations in time and place of the basic costs for material, skilled and unskilled labour. Relative fluctuations may shift the price comparisons, as they were presented in Figure 4.4.

From the calculations, the relative cost contributions of the production factors can be deduced and can be used to get an insight into the influence of alterations in price levels. This is illustrated in Figure 4.6.

4.4 Cost-efficiency assessment of the treatment

The efficiency of the treatment process applied in the different sanitation programmes can be measured in terms of oxygen consuming substances and pathogens. One can also envisage to include other water quality parameters, but in this context this is of little value.

4.4.1 Oxygen consuming substances

Most sanitation schemes equate health risk with pathogens and thus with black waste water. This approach has its particular value and emphasizes a public health strategy (minimizing local health risk). It attaches less priority to two consequences, of which the second is of particular relevance:

- black waste water and sullage have a high BOD content; if black waste water is percolated into the soil, and sullage left untreated, the latter will stress the receiving aqueous environment as its BOD load is comparable and sometimes higher than that of black waste water. Reported loads for black waste water are 15 (USA) - 25 (Asian countries) g BOD/cap.d, and for sullage 5 (low water consumption, some 40 L/cap.d) - 20 (urban Indonesia, water consumption 120 L/cap.d) - 35 (urban USA, water consumption 300 L/cap.d) g BOD/cap.d

- in many situations priority is attributed to waste percolation into the soil over the safeguarding of the shallow ground water (assuming, possibly wrongly, that the additional cost for surface management of the waste water is higher than the cost to the society of providing water supply to the poorer areas). If this priority would be reversed, it would mean that both waste water flows should preferably be treated on-site in order to remove as much as possible contaminants before conveying them to a receiving water body, or re-using them. Here the BOD removal efficiency of a treatment process is of importance.

In *Chapter 3* the performance of reactors on this parameter is described. *Figure 4.7* correlates the efficiency on this parameter with the cost.

UASBs have a clear advantage over septic tanks, particularly if they are applied as an on-site "mini" or pre-treatment plant for the grey waste water, before it is conveyed in a drain or sewer to a receiving water body.

In other words, if the overall strategy is orientated towards ground water protection and environmental protection, then the UASB can be considered a treatment process proper, although its efficiency is too low to make it a complete treatment.

Septic tanks are basically good settling facilities that also perform reasonably well in BOD removal from heavily loaded black waste water, but they would fail for treating more dilute grey water.

4.4.2 Pathogens

None of the considered treatment facilities has a good removal rate ($\geq 99.9999\%$) for pathogenic viruses or bacteria. Any significant removal in on-site options takes place as a consequence of soil infiltration. The UASB, however, shows reasonably good performance with regard to removal of the (settleable) ova of helminths, notably if only black waste water is treated (RIVM, AUW and St. Borroméus, 1988). This aspect will be discussed in greater detail in *Section 5.3.4*.

Consequently, UASB "treatment" is not able to meet stringent standards. However, it should be noted that no alternative is available that does.

4.5 Conclusions

Conclusions are based on the outcome of the simulation study described above, and their validity should therefore be judged in the light of the used assumptions

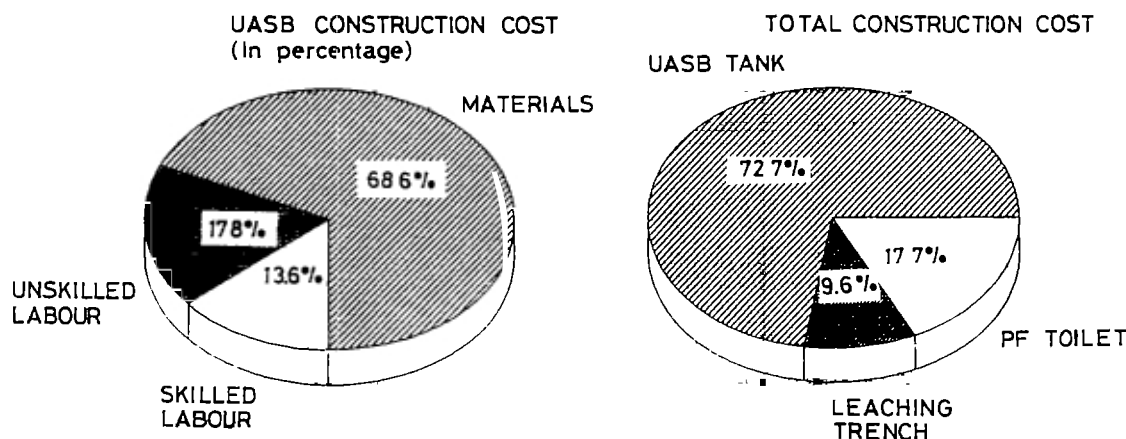

Figure 4.6 Relative contributions to constructions cost for an individual or shared UASB, and for a total on-site sanitation system with a UASB tank.

1. A detailed on-site sanitation simulation study was carried out in an urban and semi-urban context to investigate (i) which on-site options can be identified as being **technically** appropriate, (ii) which on-site options can be identified as **economically** feasible, (iii) which options can be identified as **financially** affordable, and (iv) whether UASB technology has a function in this perspective.

This simulation is performed on Indonesian test-cases, that are thought to be representative for Indonesia, as well as, in principle, for most similar urban and semi-urban settings in other developing countries. The study is "township-centered," calculating all costs for different sanitation strategies incurred within the physical boundaries of the township.

Individual systems

2. **Single leaching pits are always at the cheapest side of the alternatives** with TACH of Rp 30,000-50,000 depending on conditions, and monthly downpayment requirement of typically Rp 1,200. Even in the most

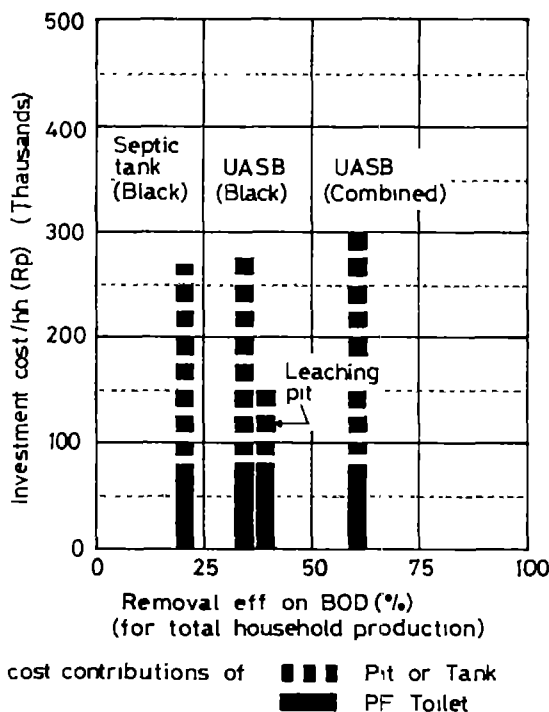

Figure 4.7 Cost-efficiency relation as expressed in terms of net removal of BOD for (i) the UASB that treats only black waste water, (ii) the UASB that treats all household waste water, (iii) the septic tank that treats only black waste water, and (iv) the leaching pit receiving black waste water. The mentioned costs are only indicative as they are dependent on a number of input values, such as interest, relative costs of labour, materials, etc.

densely populated areas (= 800 cap/ha) pits could still be constructed underneath existing structures. The good financial performance is related to a high degree of possible community participation (up to 33% of total construction cost). The pit is also a very reliable and fool-proof technology.

Counter-indications are (i) very high population density because of lack of accessibility to remove sludge, although this should not be done more often than every 4-6 year, (ii) poor soil permeability, and (iii) the contamination of shallow ground water.

The Indian experience of Sulabh Int (Sinha and Ghosh, 1990) however, shows single leaching pits often fail because owners dislike removing the wet sludge. Double pits prove to be more appealing.

3. **The double leaching pit is financially feasible** if population density is below 200 cap/ha for unplanned and 400 cap/ha for planned area. Desludging is required every year.

Strong technical counter-indications are (i) medium to high population densities, (ii) high water table and (iii) poor soil permeability.

4. Septic tanks are always relatively expensive (TACH of Rp 60,000-80,000). Individual UASBs are always typically 15-25% cheaper on TACH (partly because they need a smaller quantity of building materials) than septic tanks, but they fall nevertheless in the same higher price category. Lined pits also function as septic tank, but are cheaper than these. Best desludging frequency is once every 2, 3 and 4 year for UASB, septic tank and lined pit, respectively.

5. If overflow from septic tank or UASB is percolated into the soil, costs are usually typically 5-10% lower than when it is removed through an open drain or shallow sewer system. Generally speaking there are always financially and otherwise more competitive options available. Leaching trenches cannot be applied any longer for higher population densities. Leaching has the disadvantage of contaminating the shallow ground water.

6. Community participation may extend to:

- providing some in-house structural elements, and unskilled labour for the construction of the facility itself, as well as for house connections, leaching trench, and possibly the drain and shallow sewer;
- maintenance of the facility itself, and of the drain and shallow sewer if available, in addition owners must be well-motivated and possibly trained to make them aware of the importance of the appropriate use of the facility and of its regular desludging.

Shared facilities (5-10 households)

7. Shared UASBs and septic tank systems are, everything taken into account, only 10% cheaper on TACH than their individual issues. The gain in tank construction cost is partly compensated by the additional cost of the sewerage. They are still 40-50% more expensive than single leaching pit systems

8. Community participation may extend to:

- the relatively limited possibility of providing labour and structural elements (pour-flush toilet),
- in the kampung, or at least in the close neighbourhood, the maintenance of the sewer connection (de-clogging) and of the tank, as well as organising the timely desludging. Given the small size of the circle of owners (5-10), it will not be necessary or possible to set up a somewhat formal organisation for this latter purpose, drain and sewer maintenance needs a certain degree of formal organisation under the responsibility of the village or neighbourhood headman.

Communal facilities (20-110 households)

9. The scale effect of increasing the number of connected households from 20 to 110 is modest, with a gain (in TACH) of 15% for UASB systems and 18% for septic tanks. The number of dwellings that can be served by one unit is limited by the maximal "affordable" length of shallow sewer between the dwelling and the unit.

However, at population densities below 200 and above 600 cap/ha communal systems may financially not be effective.

10. The communal UASB is on TACH 3 to 20% more expensive than the single leaching pit, communal septic tanks are 16 to 37% more expensive than the communal UASB. UASBs are again cheaper than septic tanks.

For the communal UASB, the cost is made up for only one fifth by the reactor and two thirds by the waste water collection system (shallow sewer, house connection, grit trap) Because of a high portion of possible self-help (up to 57% of total construction cost) **the overall financial picture of the communal UASB is attractive as compared to that of alternatives and makes this option affordable.** Biogas can probably not be recovered and used in an economically attractive and safe way.

11. Communal facilities have the specific advantage that they can be located near an access road, thus greatly facilitating desludging

12. Community participation may extend to:

- provision of some in-house structural elements, and, in particular for UASB based systems, unskilled labour (house connection, grit trap, etc.);
- in the kampung, the maintenance of the sewer connection (de-clogging) and of the tank, as well as organising the timely desludging. Given the fairly large size of the circle of owners, it will be necessary to set up a somewhat formal organisation for this latter purpose; drain and sewer maintenance needs a similar degree of formal organisation under the responsibility of the village or neighbourhood headman in close cooperation with the authorities responsible for Public Works and Public Health.

Similarly, it can be argued that the local formal organisation in fact represents a considerable institutional advantage, that may determine the eventual success of the sanitation programme. It is common experience that it takes much pain to motivate house owners to invest in on-site sanitation, even in a cheap form.

To ensure proper use of it in the long run it may be considered an even greater task given the general reluctance to deal with waste. Motivation and control of facility holders lie with local or provincial authorities who are not capable of individually addressing all owners. However, if a community (kampung or neighbourhood) could organise itself under the guidance of the local authority, and appoint (and provide a small fee for) a part-time caretaker from their own circle, the authority would have to deal with only one representative for every 100 households. In addition, an appointee can be better held accountable, both by the community that pays him and by the responsible authority.

Environmental protection

13. Most on-site sanitation programmes are defined by the public health strategy that aims at removing pathogens from the direct living environment by percolating the black waste water into the soil. This strategy gives no priority to shallow ground water protection nor to environmental protection because the drained sullage carries more BOD load than the black waste water.

The UASB treating grey waste water, for example in a programme where waste water is no longer allowed to percolate into the soil, is in terms of cost-efficiency (on BOD removal) far more attractive than any other alternative. It could possibly play a role as local pre-treatment before its effluent is further conveyed to more advanced treatment or a re-use scheme (irrigation, fish ponds) An essential prerequisite for

success is in that case of course a stringently applied desludging and maintenance of the numerous small reactors.

None of the treatment alternatives removes pathogenic viruses or bacteria in sufficient amounts. The UASB removes fairly well helminth ova, better than other treatment alternatives. As stated before, this means that special restrictions might be necessary for the disposal of the sludge.

14. The novel option of township based systems using UASBs will be further discussed in *Section 6 2*.

5 Anaerobic Waste Water Treatment at Off-site Scale

5.1 Introduction

5.1.1 The sewage treatment

In the case of on-site treatment, the treatment process as such is only a minor and less controllable part of a more comprehensive programme. When dealing with off-site treatment, the treatment process becomes an important link in the chain of activities. It becomes possible to manage and optimize the treatment process. As a consequence, this chapter will concentrate on the treatment as such, more so than was the case in the previous Chapter

As described in *Chapter 2*, the waste water of (part of) the city may be collected in a sewerage system and transported to an off-site facility where centralised treatment and disposal can take place. Centralisation is assumed to bring about higher efficiency thanks to better management, as well as lower unit costs due to economies of scale. On the other hand, sewerage is very expensive (at least of the same order of magnitude as complete treatment). Centralised treatment provides maximum control over waste water flows, the removal of specified waste water components up to given standards, the handling of side-products like sludges, and the eventual disposal of end-products. This is of particular relevance in re use schemes

5.1.2 The sewage collection

The waste water collected by **separate sewers** usually contains the domestic grey waste water plus industrial and trade effluents (for example from laundrettes, shops, household industries, garages and service stations, and small workshops). **Combined sewers** may also carry large amounts of rain water as well as urban run-off, the latter sometimes containing high concentrations of suspended and settleable matter like sand. Due to the irregular water flow in the combined sewer, pollutant concentrations (notably BOD, COD, settleable matter) as registered at the treatment plant's inlet vary considerably (with factors 2 to 10) within short periods (0.5 to a few hours).

In both cases (separate and combined sewerage) ground water may seep into the sewer and be transported to the treatment plant, leading to pollutant dilution. Conversely, if the ground water table lies below a sewer which is not watertight, waste water may percolate into the soil.

Any treatment facility will have to be carefully sited and sized in function of a number of considerations which take full account of the effects of the sewer system. From a financial-economic point of view, optimal site and size will be determined *i.a.* by the combined cost – in the form of a Net Present Value – of the sewerage plus the complete treatment facility plus the land cost. In the case of decentralised treatment, *i.e.* not too far from the place of waste water production (a township or city quarter), it should be borne in mind that the plant's effluent must be conducted through transport pipes or drains to the point of discharge, thus adding also to the cost.

5.2 Criteria for selecting off-site treatment reactor types

This Section outlines the criteria, which relate to the determinants brought forward in *Chapter 2*, which a waste water treatment process has to meet in order to be feasible. These criteria will be used to determine under which conditions large-scale high-rate anaerobic reactors are competitive with existing treatment alternatives, or in how far they provide solutions for problematic situations that have been left without adequate answers up to now

Feasibility means in general terms that a plant is:

- i) **efficient** if the basic performance of the plant is such that the desired effluent quality can be achieved at reasonable cost;
- ii) **effective**: if the plant can operate satisfactorily and consistently meet the required effluent criteria under normal working conditions, which vary as a consequence of the dynamics of the waste water collection and transportation network;
- iii) **reliable**. if the plant is not likely to be severely disturbed by unfrequent extreme working conditions, like hydraulic, organic and toxic shock loads, or occasional faulty operation,
- iv) **technically manageable** if the normal operation and maintenance can be carried out without extensive or complicated measures (specialist assistance, long overhaul periods, sophisticated instrumentation).

Within the purpose of this study, these general terms are translated into more operational criteria.

1 Environmental feasibility

(Discussed in *Section 5.3*)

The treatment process selected will have to meet a defined effluent quality, according to standards set by national environmental, water management or public health authorities. The discharge standards as determinants for an environmental feasibility have been discussed in *Section 2.5*. Further, it must be possible to dispose of produced sludge.

2. Reliability

(Discussed in *Section 5.4*)

It must be possible to design the plant for specified effluent quality, so that the plant is not sensitive to normal variations in working conditions (as measured in effluent quality changes), that the plant's operation is not likely to be disturbed by infrequent yet normal extreme working conditions, and that, when it has suffered damage, it is fairly easy to repair or restart.

3. Institutional and technical manageability

(Discussed in *Section 5.5*)

In developing countries few governmental agencies are familiar with waste water management. In order to plan, design, construct, operate, maintain and finance waste water treatment facilities, appropriate sectoral institutions have to be developed. These may be located within local or regional government, water resources or river basin authorities, or public utilities corporations. Other influential groups of actors are the contractors, the professional associations, the educational system, and the scientists and technologists. New technologies will rely more heavily on the quality of those groups, but generally speaking their familiarity with waste water management is only low to fair in developing countries.

Feasible treatment technologies should be fairly simple to operate and maintain, even under more extreme working conditions. Operation also covers the management of possible side-products like sludges. The more reliable and insensitive (to variations in working conditions) a technology is, the easier its operation becomes.

4 Cost and financial sustainability

(Discussed in *Section 5.6*)

The lower the economic and financial costs, the more attractive a treatment technology is when compared with alternative options.

However, even the lowest cost option may not be financially sustainable, as this is determined by the true availability of funds determined by *e.g.* the capacity and willingness of the served population to pay for the service. The goal of urban infrastructure provision

should be full cost-recovery, though this may need the introduction of special financing schemes, involving *e.g.* cross-subsidization, revolving funds and the use of labour provided for free by the community. Therefore, only technologies that meet these criteria, *e.g.* by allowing phased investment, can be considered feasible.

5 Possible application in re-use schemes

It was stated in *Chapter 1* that re-use of partially treated waste water could in the future gain importance in developing countries. Re-use covers land application (sewage farming), aquaculture and pisciculture. Depending on the situation, the waste water will have to meet specific quality requirements. The opportunities of anaerobic treatment in this respect will be discussed in *Chapter 6*.

In the forthcoming Sections, the above mentioned criteria will be applied on waste water treatment processes, and the significance of anaerobic processes will be analysed.

5.3 Environmental feasibility

Table 5.1 synthesizes the quality parameters for weak, medium-strength and strong sewage or grey waste water. As rough figures, these values can be thought representative for most countries around the world.

Table 5.1 Characteristics of raw waste water (in mg/L) (Metcalf and Eddy, 1984)

	Weak	Medium	Strong
BOD	110	220	400
TSS	100	200	350
Nkj	20	40	85
Ntot	20	40	85
P	4	8	15
Faecal coli	10 ⁶ /100 mL	10 ⁶ /100 mL	10 ⁶ /100 mL

Table 5.2 provides typical values for the efficiency of the most frequently used "proven" technologies for sewage treatment. The values mentioned are averages. More details on selected treatment technologies can be found in *Appendix 1*. Performance data of anaerobic reactors on sewage was described in *Table 3.2*.

The purification (removal) efficiency of a waste water treatment process is described using water quality parameters as listed in *Section 2.5*. Removal of BOD

(or COD), Kjeldahl-nitrogen (N_{kj}), suspended solids (TSS) and pathogens will be reviewed in the following subsections. In *Section 5.3.1* average efficiencies, their variance and percentile-values are discussed.

5.3.1 Oxygen consuming substances: BOD and COD

a. Efficiency and effectivity of aerobic processes

Generally speaking, plant effluent values are thought of by legislators and designers as an average value with a small variance. However, affected by temporary process deviations inside the reactor, and by changes at the influent side of the plant (sewerage dynamics), large fluctuations in effluent quality do occur. Trentelman (1981) evaluated the statistical characteristics of 80 operation years of 42 Dutch activated sludge plants (including oxidation ditches) and trickling filters. The effluent quality values expressed as BOD, COD, or any other quality parameter of full-scale plants are distributed according to a non-Gaussian distribution pattern which is strongly skewed to the higher values. It appears therefore useful to distinguish between average and median values for effluent quality.

Figure 5.1 indicates the relation between the yearly average BOD value from 80 operation years of well-functioning **activated sludge and oxidation ditches** (based on analyses of daily average samples), and the BOD-percentiles. The average always falls between the 60- and 70-percentile, stressing the pronounced right-skewedness. A 95-percentile value means that this value will be exceeded in 5% of the cases (or during 18 days of a year), it can be seen that these values are markedly higher than the averages and medians. For example, if the BOD average of an effluent is 15 mg/L, the same effluent will in 20% of the cases (73 days per year) carry a BOD of 21 mg/L or higher, and 18 days even 35 mg/L or higher. Conversely, if legislation sets maximum effluent BOD at 20 mg/L, plant design needs to be such that the average (expected) effluent BOD is 8 mg/L, such a measure would be a technically severe (and expensive) standard, but would still imply violation of this standard during 5% of the days.

The variance on performance of **trickling filters** is even more pronounced, particularly of installations with a medium to high volumetric loading. This is a remark typical for trickling filters in general, but it will

Table 5.2 Performance of major conventional waste water treatment technologies. Values are to be understood as typical averages. In all cases performance can be greatly influenced by process modifications and loading rates, temperature, waste water characteristics, etc.

	Removal (%)				Effluent TSS	Gas* production	Sludge production	Ref.
	BOD	N _{kj}	N _{tot}	P	mg/L	L/(cap.day)	kg DM/ kg BOD removed	
Primary sedimentation	20-30	15-20	0	-	-	-	-	1, 2
Activated sludge: High load	90	25	30	30	25	17-35	0.9-1.0	1, 2, 3
Low load	95	75	55	45	10	20	0.5-0.7	1, 2, 3
Oxidation ditch	95-98	80-90	50-70	10-20	10-15	0	0.3	1, 2, 3
Trickling filter: High load	80	20-35	25	-	45	14	0.6	2, 3
Low load	90	60-80	35	-	25	-	0.4	2, 3
Rotating biological contactor	90-95	50-75	-	-	-	-	0.6	4, 5
Aerated lagoon	70-80	-	-	-	-	0	0.03-0.08 m ³ /cap.year	1, 2
Ponds system**	80-90	-	50-90	-	50-75% removal	0	0.03-0.08 m ³ /cap year	1, 2, 6

1 = Arceivala (1981)

2 = Metcalf and Eddy (1984)

3 = STORA (1988)

4 = Ministerie van de Vlaamse Gemeenschap (1985)

5 = Wijnhuizen and Nelissen (1983)

6 = Arthur (1983)

* ± 85% CH₄ in case of anaerobic digestion of excess sludge

** Part of BOD, nutrients and TSS is transformed into algae.

be more pronounced in moderate climate zones, as the filter efficiency tends to be very sensitive to low (winter) temperatures. In winter time, nitrification usually comes to a halt

Little information is available on the predictability of the effluent of **waste stabilization ponds**. Jurgensen (1982) reports about a statistical analysis of concentrations in un aerated three-stage pond effluents in Schleswig-Holstein (W-Germany). A median value for BOD of 7 mg/L is combined with an average of 9 mg/L and a 80-percentile of 15 mg/L. The influent BOD was generally low but was very variable, average was 179 mg/L with standard deviation $\sigma = 230$ mg/L. Obviously the ponds are fairly accurately dimensioned and well-operated, given the low and constant effluent concentrations and their narrow margins. It is unlikely that similar good results will be found for all ponds in other countries. In West-Germany ponds performed systematically better than other systems.

It should be understood that all of the above pertains exclusively to treatment plants under normal operation conditions, that is, with omission of periods of malfunctioning (bulking sludge, mechanical fail-

ure), or taking into account storm water overflows (during rain events excessive water in combined sewerage by-passes the treatment plant). "Malfunctioning" may pertain to a few days or a few weeks yearly. It can therefore be concluded that aerobic treatment, though reliable, may in fact be less effective than can be deduced from conventional average performance figures.

b. Efficiency and effectivity of anaerobic processes

The advantageous position of high-rate anaerobic processes, as exemplified by the UASB, is illustrated in Figure 5.2 where average efficiency on BOD removal is set out against the required hydraulic retention time (HRT). The HRT is a measure for reactor volume and thus an indication of capital cost (though it is acknowledged that the high-rate system is basically a civil engineering construction, and the low-rate lagoon options are cheap on the construction side but need much surface), the graph represents therefore a cost-effectivity relationship. All mentioned competitive systems are known as typical "low-cost" options: single anaerobic ponds, lagoons (channels) with floating aquatic macrophytes (FAM), series of lagoons and stabilization ponds. A well-designed and well-operated anaerobic reactor appears very attractive; efficiency is limited by a ceiling value, but it is substantial and achieved at a very short HRT. FAM lagoons need an intermediate HRT for a somewhat higher efficiency but studies report variable results. Stabilization ponds yield the best and most reliable results at the expense of very high HRT (typically 20 days or longer).

Very few reports that discuss performance of **anaerobic reactors** provide sufficient data to arrive at a sufficiently complete analysis of the variance on their effluent quality.

An available set of data results from the UASB pilot plant study in Cali, Colombia (Haskoning, AUW and Emcali, 1989). Effluent quality frequency distribution is characterized by considerable variance, and strongly skewed to the right (to the high values). Removal efficiencies, on the contrary, are skewed to the left (to the lower values); this implies that averages on efficiency yield lower numerical values than medians do. Despite the common tendency to look rather at averages than at median values, it is acceptable to consider medians, as these are values that are met or achieved in 50% of the cases (here, in 50% of the effluent samples, each individual sample in principle being expected to meet the standard). On the other hand it should be noted that in the described case week-averaged samples are used, which in itself will tend to flatten out extremes. The mentioned report

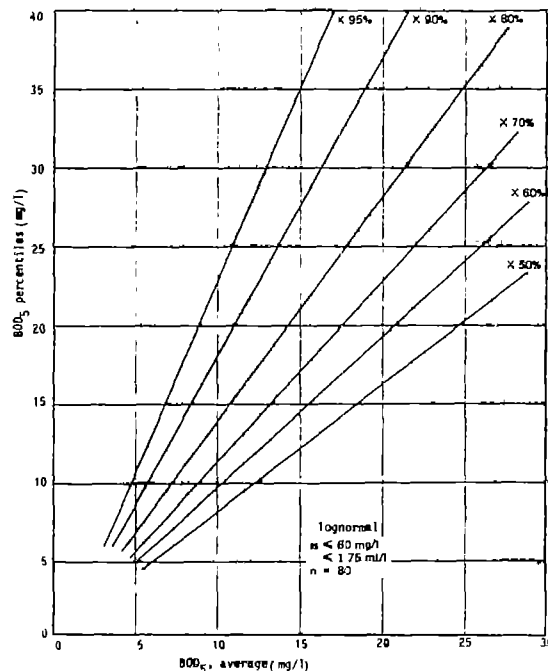

Figure 5.1 Relation between yearly average and percentiles of effluent BOD. n is the number of operation-years under normal, undisturbed operation. Pertains to activated sludge and oxidation ditch plants in The Netherlands. (Trentelman, 1981).

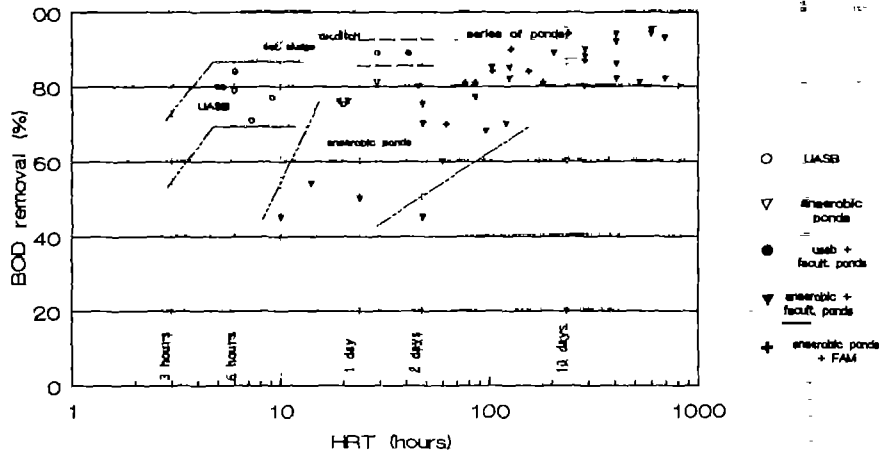

Figure 5.2 BOD removal efficiency as a function of the hydraulic retention time (HRT) is the treatment plant or pond system FAM means floating aquatic macrophytes. (Various authors).

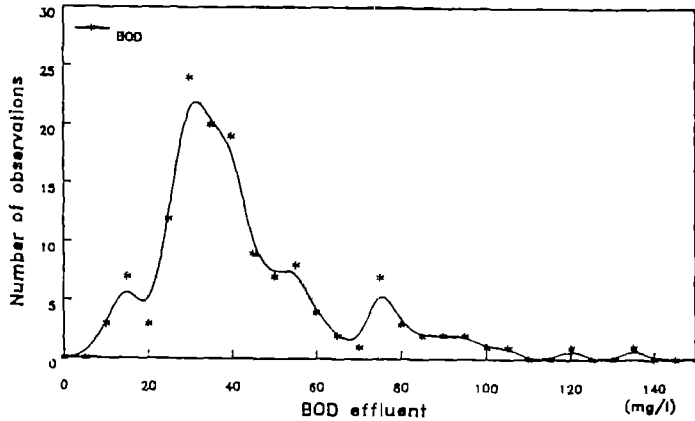

Figure 5.3 BOD effluent of the UASB pilot plant in Cali, Colombia (Haskoning, AUW and Emcali 1989)

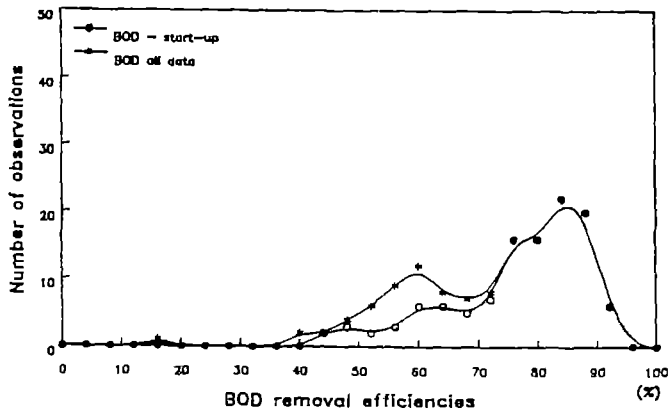

Figure 5.4 BOD removal efficiency of the UASB pilot plant in Cali, Colombia (Haskoning, AUW and Emcali 1989)

claims an average BOD removal efficiency of app. 77%, yet the actual values range from 40 to 90% with the median around 80%. COD removal values range from 30 to 85%, with the median around 64%, and the average around 60%. The reactor produced an effluent with a BOD concentration ranging from 10 to 130 mg/L, with the median around 45 mg/L, influent BOD concentration fluctuated around 200 mg/L.

Figures 5.3 and 5.4 show the frequency distributions of the week-averaged BOD concentration and the corresponding removal efficiency for the described case. The high variance on the reactor's performance is borne out. The variance could be in this case related to the fact that data pertain to sewage from two different sewers. There is reason to believe that the observed behaviour is to some extent typical for anaerobic once-through reactors (UASB and anaerobic filter). Aerobic reactors, on the contrary, feature considerable recycle flows, creating relatively intensive mixing of fresh (pre-settled) and already treated water, their results are also flattered by the fact that they commonly comprise three steps (primary sedimentation, aeration, secondary sedimentation). Nonetheless, there is certainly a scope for improvement of the consistency of results of anaerobic reactors as both design and operation can still be optimized.

The experience with the reactor in **Kanpur**, India, is still too limited to allow for a statistical treatment, but under the present conditions relative standard deviation on effluent quality can be estimated for BOD at 12% around an average of 50 mg/L, and for COD at 15% around an average of 160 mg/L (Alaerts *et al.*, 1989). The recent results over 1990 show a sustained average effluent quality of 40 mg BOD/L. The values pertain to experimental conditions without diurnal flow fluctuation, but with irregular halting and changing of flow. This reactor could thus possibly achieve better results in terms of more constant effluent quality than the (smaller) Cali plant.

From Table 5.3 it appears that reporting on the performance of the UASBs has been up to now somewhat too negatively formulated, by using average rather than median values. Further, as will be concluded later, the average effluent quality anaerobic technologies yield in one single step is usually above standards, thus necessitating a post-treatment, this will certainly lead to a significant reduction of the variance on effluent quality.

Comparison of Tables 5.2 and 3.2 with regard to BOD removal efficiencies shows that single-step anaerobic reactors, at least in the UASB mode, fall 10-20% short

Table 5.3 Synthesis of typical data illustrating variability in BOD removal of 3 treatment technologies.

Technology (Loading)	BOD-Effluent (mg/L)		
	Average	Median	X ₉₀
Act sludge (0.1 kg BOD/kg MLSS.d)	8	7	12
Trickling filter (10 cap/m ³)	23	20	30
UASB Cali (6 h HRT)	34	32	42

1 Activated sludge and trickling filter data pertain to situation in The Netherlands in the seventies (Trentelman, 1981)

2. UASB data from a long-term demonstration plant study in Cali, Colombia, data include influence of realistic flow fluctuations (Haskoning, AUW and Emcall, 1989)

of the performance of the conventional (mostly aerobic, and with three "steps") alternatives. Effluent standards in Table 2.6 indicate that it is unlikely that the single-step anaerobic technology can always meet them assuming the reactor capable of achieving systematically 70-80% BOD removal, effluent from a weak and medium-strength sewage would have a BOD effluent concentration of 22-33 mg/L and 44-66 mg/L, respectively. For a number of discharges on rivers, particularly in developing countries, the first effluent quality would be certainly temporarily acceptable, but the second would in practice be rarely tolerated. As sewage strength is likely to fluctuate in any sewer, single-step anaerobic reactors can, as a rule, not be recommended as complete treatment. Anaerobic reactors should therefore be regarded as (major) pre-treatment, to be extended with an aerobic or physical second treatment step. This extension may be implemented in a later phase, but all necessary steps for its construction should be taken from the beginning, included the provision of the additional space.

Removal performance for COD in anaerobic plants is 10-20% lower than BOD removal. Although COD is a useful parameter for operational control of a treatment plant, it usually bears limited value in the assessment of the pollution degree of water bodies.

5.3.2 Kjeldahl-nitrogen

Total reduced nitrogen (Kjeldahl-nitrogen) is an important component of the oxygen demand of anaerobic effluents. If Kjeldahl-nitrogen is discharged into warm surface water (with temperature above 12 °C), the omnipresent nitrifying bacteria will slowly start to nitrify, consuming dissolved oxygen (NOD). Western European sewage contains 60 mg N/L as Kjeldahl-

nitrogen (median value), representing $60 \times 4.57 = 274$ mg O₂/L oxygen demand (NOD). This is of the same magnitude as the oxygen demand for BOD removal. In The Netherlands, regulation requires 75% removal during summer, nitrification in surface water proceeding sufficiently slowly in winter to avoid oxygen depletion.

The zero nitrification level in anaerobic reactors could consequently be a distinct disadvantage, as it necessitates aerobic nitrification as post-treatment unless the effluent is put to use in re-use schemes where NOD is of lesser concern. Such situations are, however, not yet common.

The alternative, aerobic reactors, like activated sludge treatment plants and trickling filters, can be designed to have a limited or an extensive nitrification degree, by allowing for a high or a low sludge loading (kg BOD/kg MLSS.d), respectively. Oxidation ditches and pond systems usually apply such low sludge loading rates that nitrification is nearly complete. Of course, the low loading rate to allow for nitrification and the additional oxygenation increase the treatment cost also considerably. In this sense anaerobic treatment does not perform much worse than its high-rate aerobic alternatives (mechanically aerated systems, and trickling filters); low-rate ponds however appear more attractive as they automatically induce significant nitrification.

When providing aerobic post-treatment for anaerobic effluents, the reactor must preferably be designed for both BOD and Kjeldahl-nitrogen removal, the latter requiring the largest allowance in terms of reactor volume and aeration capacity. In most cases therefore, aerobic post-treatment tends to become more complicated and costly than would be expected on the basis of the assumption that "only" a small amount of remaining BOD has to be removed.

5.3.3 Suspended solids

The success of a treatment system strongly depends on its capacity to remove suspended matter, irrespective of the question whether this is original, by-passed sewage material, or washed-out biomass. In addition, the settling step appears to be very sensitive to disturbances (flotation phenomena, bulking sludge) which regularly affect the performance of many treatment plants.

Well-functioning aerobic waste water treatment plants applying suspended growth principles, like **activated sludge systems** and **oxidation ditches**, produce effluent with, on the average, small amounts of suspended solids, usually less than 30 mg/L. Operational practice in The Netherlands shows that suspended solids concentration depends notably on the load-

ing of the installation, resulting in better quality with lower loading rates. Still, suspended solids concentration in the effluent is very variable, due to poor solid floc build-up, as well as inappropriate design and operation of the secondary clarifier. Trentelman (1981) calculated that average concentration of Total Suspended Solids should be as low as 14.5 mg/L, to meet an effluent standard of 30 mg/L as 90-percentile value. The yearly average values for individual plants vary from 4 to 16 mg/L for low-loaded (0.02 kg BOD/(kg MLSS.d)) to high-loaded (0.5 kg BOD/(kg MLSS.d)) installations.

Trickling filters are characterized by higher yearly averages and a higher variability: in The Netherlands yearly averages vary from 10 to 50 mg/L for low-loaded (3 cap/m³ bed) and high-loaded (20 cap/m³ bed) plants, respectively (Trentelman, 1981) (see also Table 5.2). As a rule, attached growth reactors like trickling filters and rotating biological disc reactors are designed on the assumption of minimal loss of particulate material (in the form of not-yet-settled primary particles, or debris from the biomass layers), quite contrary to suspended growth systems they tend therefore to be less good in net removal of suspended matter.

The Suspended Solids in anaerobic reactors of the UASB-type is usually sufficient to meet standards (compare values of Table 3.2 with those of Table 2.6). In the case of the Kanpur reactor and the discharge standards for the Ganges, however, this is not the case, effluent carried an average 160 mg/L SS, with a standard deviation of an estimated 20%. The reactor performance is likely to be further improved. The effluent BOD and COD of anaerobic – and aerobic – reactors can be largely attributed to the presence of the suspended solids. Any gain or loss in removal efficiency for suspended solids will be reflected on BOD and COD removal efficiency.

5.3.4 Pathogens

Waste water treatment technology in industrialised countries aims primarily at removal of oxygen consuming substances, neglecting the importance of pathogen control. In most developing countries however, large parts of the population make use of surface and ground water, without paying attention to its bacteriological quality. The cyclic transmission route of excreta related pathogens from human waste (water) to ingestion, is a major reason for the poor public health situation in many of these countries (Feachem *et al.*, 1983).

Pathogens can be ranked in various ways.

- in terms of physical characteristics, we can distinguish (i) viruses, (ii) bacteria and protozoae, and (iii) the eggs (ova) of worms and other helminths (the persistent protozoan and bacterial cysts also fall in this category); this enumeration also reflects increasing size of the organism:
- according to their infective dose, *i.e.* the amount necessary to infect a person; some organisms are infectious at low dose (ingestion of $< 10^2$) like enteric viruses, whilst others require very high doses (ingestion of $> 10^6$) like *Vibrio cholerae*;
- according to their persistence in the environment outside the human body, with survival periods ranging from less than one day to several years, as is the case with the ova of *Trichuris*;
- according to the possibility that humans acquire significant immunity upon first infection; significant immunity against *Salmonella typhi* can be developed, but this is clearly not the case for worms.

Human waste (faeces) may contain small to considerable amounts of various types of pathogens, some of which are routinely present, and others only in the case of infection.

It may be understood that still very little is known

about the pathways and fate of all pathogens of concern once excreted. Only rarely do waste water treatment researchers take the pain to select representative indicator organisms to study treatment efficiency. It must be borne in mind that in order to be effective virus and bacteria removal in most cases necessitates removal efficiencies of 99.99% and higher, given the large amounts of these pathogens in waste water (Table 5.4), and given the infectious doses. This required removal efficiency is thus 1 to 3 orders of magnitude higher than what is expected in the removal of BOD and suspended solids. On the contrary, helminth ova tend to be present in much lower concentrations, and require lower removal efficiencies (90 to 99%).

Figure 5.5 gives the position of anaerobic reactors as compared to competitive "low cost" options with respect to removal efficiency on faecal coli. The HRT required for the given removal efficiency is an indication for the cost involved. The graph highlights that HRT is a key parameter that determines coli removal. HRTs below typically 20 days tend to deliver insufficient efficiencies, irrespective of the type of the process

Table 5.4 compares the removal efficiencies of major categories of off-site treatment technologies:

Table 5.4 Possible output of some pathogens in the faeces and sewage of a tropical small town (most data from Feachem *et al.*, 1983). Reported removal efficiencies that can be achieved by well-operated on-site septic tanks, conventional aerobic sewage treatment (primary settling followed by activated sludge and trickling filters), ponds (25 d retention time), and UASB

Pathogen	Total number excreted per infected person per day	Conc. in sewage (-/L)	Best removal efficiency (%)			
			Septic tank	Aerobic treatment	Ponds	UASB
a. Viruses						
Enteric viruses	10^6	5,000	99	99	99.99	99
b. Bacteria and protozoa						
Faecal coliforms	10^{10}	10^6	90	99	99.9999	90
<i>Salmonella</i>	10^6	7,000	90	99	99.9999	90
<i>Shigella</i>	10^6	7,000	90	99	99.9999	90
<i>Vibrio cholerae</i>	10^6	1,000	90	99	99.9999	90
<i>Entamoeba histolytica</i>	15×10^6	4,500	99	99	99.9999	99
c. Helminths (ova)						
<i>Ascaris</i>	10^6	600	99	99.9	99.9	99
<i>Trichuris</i>	2×10^5	120	99	99.9	99.9	99
Hookworms	8×10^4	32	99	99.9	99.9	99

1 Pathogen amounts and concentrations are estimated from typical data, and use realistic infection rates and water consumption rates

2 Removal data are averages and taken from various sources (see *l.a.* Feachem *et al.*, 1983), the data for UASB are based on four years demonstration-scale plant operation in Bandung, Indonesia (RIVM, AUW and St. Borromeus, 1988) and from experience in Colombia (Schellinkhout, 1987)

aerobic treatment, *i.e.* primary sedimentation followed by trickling filters or activated sludge processes, waste water stabilization ponds (3 units in series, retention time 25 days), and the UASB as high-rate anaerobic treatment, but without any post-treatment

The Table lists selected pathogens (viruses, bacteria, protozoa and helminth ova) In principle public health objectives are met when zero numbers of these pathogens are found in the effluent One faecal indicator organism is included, faecal coli. The 1976 standards issued by the European Community for recreational surface water (fairly comparable to much of the surface water in many developing countries) set a guideline limit-concentration of 1,000/L and a mandatory limit-concentration of 20,000/L for faecal coli. From the figures in the table it appears that no treatment technology delivers an acceptable effluent except stabilization ponds with sufficient hydraulic retention time (> 20 days).

Table 5.4 brings about the following main conclusions:

1. In order to prevent as much pathogen survival as possible in a community's environment, only stabilization ponds with the indicated long retention times of 20 to 30 days are fully satisfactory.
2. High-rate anaerobic treatment systems (as UASB) and aerobic treatment plants score less well than (long retention) stabilization ponds, given the low pathogen

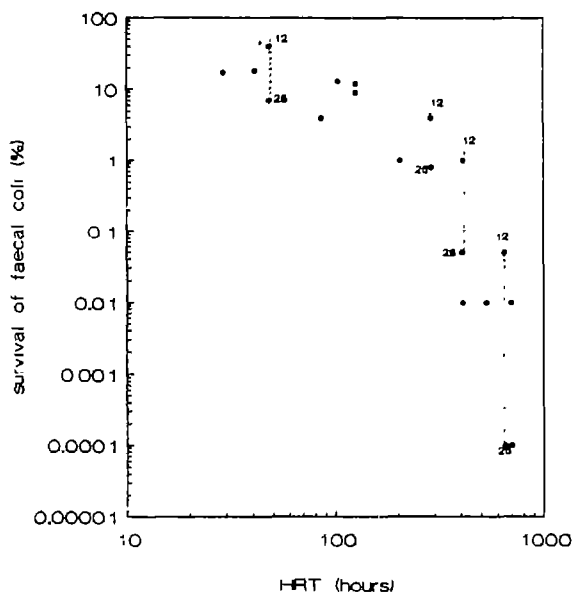

Figure 5.5 Removal of faecal coli from sewage as a function of hydraulic retention time (HRT) in different treatment plants. The figures in the graph represent temperature ($^{\circ}\text{C}$) ranges (various authors).

removal rates. The differences noted between the aerobic and anaerobic options are irrelevant from the public health point of view

3. High-rate anaerobic treatment (as UASB) performs well only on removal of helminth ova. The major mechanism for removal is entrapment in the sludge.
4. As stated earlier, to meet common effluent standards on BOD, post-treatment will become inevitable. Any post-treatment will improve the pathogen removal capacity of the anaerobic treatment, bringing it to at least that of (two-stage) aerobic treatment.

In industrialised countries it is not uncommon to apply physical-chemical treatment methods for **effluent disinfection**. Filtration, as it is used in Europe for the removal of phosphorus, appears however to be ineffective for the removal of bacteria and viruses. Chlorination of effluents is fairly often applied in the U.S.A., and rarely in Western Europe, chlorination is a "hard" approach with questionable results (chemical formation in the water of carcinogenic trihalomethanes; poor killing efficiency with respect to viruses).

Concludingly, the most attractive disinfection approaches are still derived from long-term impoundment in shallow ponds, with probably occasional chemical chlorination as a cheaper alternative. As will be discussed in Section 5.5, ponds are in most cases expensive, except when land is cheap

Since none of the options, except long-retention ponds, offer a satisfactory solution, it is always recommendable to reduce physical contact of the population with the plant's effluent. This can be attained in the following ways

- The plant discharges very close to a suitable water body with sufficient dilution capacity: the effluent can be transported through a closed sewer which is not expensive given the short distance to be covered. The closed sewer will obviously minimize contact.
- The plant discharges far away from a suitable water body with sufficient dilution capacity: an expensive closed sewer or a much cheaper yet open drain needs to be constructed. In the latter case the neighbouring communities should be educated to learn to appreciate the risks involved in having contact with the water.

5.3.5 Sludge production and handling

Any sewage treatment plant produces excess sludge. This is composed of the settleable organic and inorganic matter present in the raw sewage, and excess biomass created by the continuous growth of microorganisms feeding on the substrate. The settleable matter can be removed in a separate primary sedimentation basin (the case in aerobic activated sludge and trickling filter plants) or together with the excess

biomass (like in most anaerobic processes, and in stabilization ponds).

Aerobic waste water treatment is characterized by a high conversion ratio of soluble BOD into biomass, and thus sludge. Sludge is a cumbersome by-product: it is produced in large quantities, is composed of mostly water, necessitating relatively expensive dewatering, and it may contain pollutants, notably pathogens and heavy metals, that render re use as fertilizer impossible or difficult. From a public health point of view, re-use is advisable only after treatment like long-term digestion (20 days) or disinfection by increased temperature or pH

Table 5.5 shows typical data on sludge production.

The excess sludge from aerobic treatment however, can be easily digested, yielding sufficient amounts of biogas to make the plant energetically autonomous and cutting its operational costs by 30%

This fact, and the large share (on dry weight base) of primary sludge in the total sludge production of any sewage treatment plant, relativize the advantage of anaerobic systems that they produce up to 50% less excess biological sludge (biomass) than aerobic processes. One third of the primary sludge is mineral and is thus certainly not amenable to digestion. Nonetheless, the costs related to the sludge output of an anaerobic process are still relatively modest, and favourably affect the competitiveness of the process.

An additional competitive advantage resides in the complicated and technologically difficult nature of the mentioned in-plant biogas recovery from excess sludge digestion in aerobic treatment plants. This renders anaerobic plants more appropriate and economically attractive in less-industrialised countries

An additional advantage of anaerobic treatment is that it produces a well-digested and stable sludge, which will not rot when exposed to air. It has favourable dewatering characteristics when compared to the "fresh" sludge from aerobic plants. At the Kanpur plant, excess sludge (which included a relatively high fraction of inert matter) could be dewatered within one week (at ambient temperature of 15-25 °C), with the sludge turning into a very dry, hard and porous material, without smell and not attracting birds or insects. These advantages are reflected in the cost calculations of Table 5.9 and 5.10.

As the anaerobic reactor can usually not be considered complete treatment, it has to be followed by post-treatment (Section 6.1). If this is to be a small pond, the additionally created sludge will be limited, if it is an oxidation ditch, the amount of additional sludge cannot be ignored. If the post-treatment is a conventional activated sludge or trickling filter, considerable amounts of excess biological sludge will need to be digested prior to dewatering, rendering the whole plant more

Table 5.5 Typical data on sludge production by treatment plants (sludge includes both the settleable matter originally present in the sewage, and biological excess sludge)

Technology	Sludge quantity			Sludge stability
	(kg DM/kg BOD removed) ³	(kg DM/m ³ treated)	(m ³ /cap yr)	
Primary sedimentation	-	0.15-0.2	0.015-0.025	low ¹
Activated sludge				
high-loaded	0.9-1.0	0.2	-	low ¹
low-loaded	0.5-0.7	0.1	-	medium ¹
Oxidation ditch	0.3	0.05	-	medium ²
Trickling filter	0.4-0.6	0.09	-	low ¹
Primary sedimentation + aerobic sludge after anaerobic digestion	1.0	0.2-0.4	-	high ²
Ponds (long retention) comprises primary sedimentation sludge	0.07-0.2	0.03-0.09	0.03-0.08	high ²
UASB comprises primary sedimentation sludge	0.4-1.2 ⁴	0.1-0.2	-	high ²

¹ Sludge rots when exposed to air, needs digestion (20 d) prior to dewatering in open air

² Sludge can be dried on sand beds for dewatering

³ DM means expressed as dry matter, BOD removed refers to BOD removed in the biological step only, except for ponds and UASB

⁴ Typically 0.4-0.7, 1.2 was found in the UASB plant in Kanpur, which contained much TSS in influent

complex and expensive.

The amounts and nature of sludge produced by other anaerobic reactor types is not expected to diverge very much from what is found with the UASBs. However, if an anaerobic filter is used in down-flow mode, the settleable organic matter from the raw sewage and from the biomass is not allowed to be digested internally. This will require the washed-out sludge to be collected in a subsequent treatment step, and to digest it separately (increasing costs).

If the partly dewatered sludge is to be valorised as fertilizer for agriculture or horticulture, public health aspects need careful evaluation as anaerobic sludge, just like undigested aerobic sludge may contain pathogens. However, in view of the long average retention time of sludge in the reactor, and the subsequent dewatering in open air under exposure to sunrays for one week or longer, anaerobic sludge may be attributed a higher safety degree than undigested aerobic sludges. Separate sludge digestion is relatively sophisticated and not always advisable. Generally speaking, the quality considerations pertaining to sludge re-use are similar to those for waste water re-use (see Section 6.2.5).

5.3.6 Odours and gases

Gases emanating from the plant are usually difficult to control. The experience with the UASB pilot and demonstration plants is that odours were in no case a major problem. However, in densely populated urban areas an odour nuisance may arise if plants are large. In this case gases are to be collected and treated by compost-filters, chemical absorption or burning in a flare. If the biogas is put to use (an option which is probably feasible only when a large plant can be combined with an institutional gas user like a factory, or when biogas is used for in-plant power generation) sophisticated electro-mechanical equipment is necessary to compress, transport, condition and utilize the gas. In addition, stringent safety measures are mandatory and require a high staff discipline. In other words, gas management at the plant increases the degree of complication, which is usually not advisable in less-industrialised countries.

Odour nuisance is a problem of some importance at aerobic plants, emphasizing that in this respect anaerobic reactors, particularly if they are not large, are not necessarily scoring less well. All conventional plants suffer from corrosive and malodorous gases emanating from the raw water intake pit, grit removal and primary clarifiers. In The Netherlands and Western Germany it is common practice to cover these, collect the air above them, and treat it in (air-)compost-filters. Activated sludge plants produce aerosols (fine

water spray) which can carry pathogens for several hundred meters to neighbouring houses. Trickling filters in tropical countries are equally smelly and notorious as breeding places for mosquitoes, flies and other insects. Anaerobic ponds generally are fairly free of malodorous gases, stabilization ponds may generate scum that can be blown away by the wind, and, if not well constructed and tended, provide on its banks ample opportunity for insect breeding. Finally, some smells will be caused by the thickening and digestion of the sludge from aerobic plants.

The effect of large flows of anaerobic effluent being further treated in aerated processes (and the gases thus being desorbed in larger quantities) is still insufficiently documented.

In conclusion, the odour problem of anaerobic reactors could in many cases be of comparable importance to that of conventional aerobic plants.

5.4 Reliability

The resilience of anaerobic process against both hydraulic and organic shock loads was in the described UASB pilot and demonstration plants larger than can be expected from the once-through flow mode and the relatively short retention times.

5.4.1 Hydraulic variations

Most reported experiences (de Man and Lettinga, 1987; Jewell, 1985; Switzenbaum, 1985; Schellinkhout, 1988; Haskoning, AUW and Emcali, 1989) relate to pilot plants that operated on a constant flow rate. Sewage was in all cases pumped at a constant rate to the pilot plant from the sewer; the sewage composition in the sewer and to the plant did vary in a realistic way in function of diurnal variations and (in the case of combined sewers) of rain weather conditions, but flow rate changes did not occur on a regular basis. In the Cali plant a sudden though small flow rate change was introduced to better simulate the day/night rhythm, lowering the hydraulic retention time from an average of 6 h to 4 h; no negative effect was noted as long as minimal retention time stayed above 4 h. On the contrary, these minor flow variations were found to favour the process. The conclusions were similar for the Kanpur plant, flow was in principle kept constant during the test period, but it was regularly interrupted. The experiments with the (cold climate) reactor in Bergambacht included at some occasions variable hydraulic loadings which were in that case detrimental to good performance.

5.4.2 Variation in sewage composition

Sewers may carry systematically or inadvertently uncommon compounds and materials that affect plant performance.

During simulation tests in **Bandung** with on-site UASBs, inhibition of methanogenesis by a strong cleansing agent used in Indonesian households (lysol, a phenolic compound) was studied. Lysol exerted a pronounced inhibition at low concentration, but this inhibition never exceeded 50%, despite an unrealistic increase in lysol dosage. Unfortunately, the duration and possible recovery of the sludge was not studied, given the fact that phenol can be degraded anaerobically, it is likely the sludge will recover after possibly 1 to 2 days.

The plant in **Cali** was fed for a month with sewage containing industrial effluents, characterized by high levels of heavy metals, phenols, high pH values, etc. Although this led to less abundant digestion, no systematic negative effect could be detected. High concentrations of fats have a negative effect, being poorly biodegradable and inducing sludge wash-out because of flotation. The reactor resisted acid pH shocks for short periods of time, and to alkaline pH shocks up to pH 12 for prolonged periods, pH shocks cause a temporary reduction in gas production and some sludge loss.

The above shows that UASB reactors are not extremely sensitive, but necessitate careful supervision.

Once-through reactors possess process-wise less internal buffering capability to flatten out possible high shock concentrations. The more a technology is low-rate, and thus applies low volumetric or organic loadings, the more water volume is available in the system to dilute and buffer any discontinuities. Generally, no problems due to lack of buffering capacity occur, as long as the hydraulic loading can be controlled. Hence high-rate anaerobic systems are more vulnerable, requiring more careful design and supervision, which puts them in an unfavourable position as potential "low cost" treatment technology. Finally, the existing experience shows that the resilience of the anaerobic reactor tends to improve with the substrate (BOD) concentration in the influent.

The foregoing factors suggest anaerobic reactors are better suited to treat waste water that is (i) more concentrated, or (ii) from separate sewer systems (because these have no peak hydraulic loads combined with low BOD levels)

The consequences of inadvertent faulty operation are for the moment difficult to assess, as experience with larger scale reactors is lacking. At the **Kanpur** plant, the flushing of clogged inlet pipes had no marked

effect on plant performance; a faulty excessive sludge bleeding led to deteriorated effluent quality for one month. As long as no operational problems arise, required supervision seems to be fairly simple, and operation and maintenance limited.

Once a reactor has failed it is difficult to work or do repair or maintenance work on its internals (influent distribution system, gas collection, sludge withdrawal pipes) without shutting the reactor completely off and emptying it. Normally this will imply some sludge loss, as its exposure to atmospheric oxygen leads to (limited) activity decrease. The experience with the **Cali** plant shows the need for annual or bi-annual internal maintenance on gas collectors and concrete (corrosion), and for removing accumulated heavy sludge from the lower part of the reactor. The important parts of aerobic plants are generally better accessible.

To avoid operational problems, sound design procedures need to be followed, which are probably more plant-specific than in the case of conventional treatment. Once an operational problem develops the technical supervisor may need immediate assistance from more experienced staff since the reactor is liable to be severely disturbed a few hours after the first signs of an arising problem.

A problem of a general nature that also deserves special attention is the fact that anaerobic treatment plants that are connected to an already existing combined sewer, through which also storm water is discharged, can accept only part of the total peak flow under rainy weather conditions, as otherwise the biomass would be washed out from the reactor and sedimentation processes would be disturbed. Aerobic plants are more flexible and usually designed to accept up to 4 times the daily average dry-weather flow rate; the remainder is by-passed and thus discharged without treatment. This need not necessarily be problematic, because the storm water dilutes the pollution. However, as was shown *via* the work of Lager and Smith (1974) and Alaerts *et al.* (1982), the front of those sewer water surges can carry a pollution load which is equivalent to that of an accumulation of several days. By-passing this load means that the treatment effort of a few days is annihilated.

5.5 Institutional and technical manageability

5.5.1 The political factor

The prerequisite for effective waste water collection, treatment and discharge is the awareness of the public at large, and of the political decision-makers, that appropriate means have to be allocated to plan, con-

struct, maintain and improve the required infrastructure. The means involve

- (i) funds to start up the operations, pay annually principal and interest of loans for the investment, pay annually recurrent costs, and pay annually the cost of the institution, agency or corporation that will manage the infrastructure in the technical and financial sense,
- (ii) renewed funds after the lifespan of the project have been completed (initial investment depreciated), to start new projects to allow continuation,
- (iii) considerable managerial autonomy for the institution in order to ensure realistic planning, decision-making and implementation of projects, based on sound management procedures;
- (iv) considerable financial autonomy to support the above, allowing the managing institution to set tariffs or charges to the public ("consumers" of the service), and earn money in other acceptable ways, to arrive at a full cost recovery of all incurred expenditures on capital and recurrent items;
- (v) managerial autonomy with respect to the internal organisation of the managing institution, in order to keep it effective, flexible and professional, such implies for instance that personnel and staffing policies, promotion opportunities, human resource development and last but not least salary policies are, within reasonable limits, determined by the institution's objectives and not by external (political) considerations,
- (vi) an effective degree of cooperation and coordination between, if not integration of, interrelated sub-sectors; this may pertain to the horizontal integration of planning and management of sewerage, drainage, solid waste, sanitation and water supply in a given city, or the vertical integration of, for example, small organizations into units of viable scale.

These prerequisites are valid irrespective of the type of sewage treatment technology. Novel technologies may be more vulnerable than conventional ones, though. It is often observed that dedicated staff working under discouraging institutional conditions still perform their duty well relying on their individual sense for responsibility and their own technical insights; if this staff is not allowed to develop an operational grasp of a newly introduced technology, this will soon become abandoned.

5.5.2 The managerial factor

If the political climate is advantageous for sector development, the management and senior staff must be capable of setting up and managing an effective organisation (*Picture 8*)

This requires that the organisation is effectively organised

- (i) internally, implying the complete personnel is optimally allocated to job positions designed to identify, analyse and solve all problems; in addition the personnel is dedicated to its duties, and is capable of receiving accurate instructions as well as of passing information on to higher levels (top-down and bottom-up communication), the personnel structure is well-balanced, *i.e.* a sufficient number of the different categories is available (in developing countries organisations often dispose of qualified engineers and other high-ranking staff, but miss well-trained operators and technicians);
- (ii) externally, *i.e.* in its orientation towards the projects, in the sense that it is capable of planning, designing, constructing and operating the different components of the waste water management scheme; in addition, it (or a related institution) is effective in the collection and administration of revenues and expenses. The scheme's components cover the sewerage and drainage, treatment, and handling and possibly using sludges and effluent.

5.5.3 The societal factor

The community at large must be aware of the importance of adequate waste water management. It must be willing to contribute financially on a regular basis to a central, governmental (or semi-governmental) authority. This willingness relates to a sense of ownership, and of respectability of sanitation. In addition, it should be willing to cooperate, for example in keeping garbage out of drains and sewers, in assisting with cleaning of open drains or small-bore sewers located on their compound, and in general in abiding by the regulations.

5.5.4 The scientific support factor

Firstly, scientists and engineers in industrialised countries cope with the fast development of technologies by reading **professional journals**, attending meetings and conferences convened by **professional associations**, and by following recycling or advanced courses. These initiatives are instrumental to continuously upgrade the knowledge of the professionals and promote intensive exchange of information and experience. In addition to this formal function, the regular meetings help to foster self-confidence, a sense of responsibility and a degree of professional pride. These factors are very important to sustain the creative effort professionals are expected to bring up in their search for better and more economic solutions to environmental problems.

This corporative support is often deficient in less-industrialised countries, or it may even work in a counter-productive manner if it takes the form of an association that is to protect commercial or otherwise financial interests. The latter can happen if the association remains unchallenged by peer organisations of other professionals with competitive interests (*e.g.* sanitary engineers can be challenged by chemists or biologists, or by pressure groups).

The reason for such deficiency may be too few professionals per city or region, lack of concern, insufficient funds leading to absence of opportunities to apply new techniques, corporation or insufficient financial means to erect and sustain a viable professional association.

Secondly, the capabilities of the engineering, administrative and operational staff depend very much on the adequacy of the **educational system**. This holds, of course, to higher education institutes, but also to institutes and schools delivering technicians. If the formal schooling system is insufficiently specialized, *e.g.* with respect to the formation of plant operators and supervisors, sector organisations should provide for this themselves and organise short courses.

Thirdly, the availability of **university expertise** is of critical importance in the introduction of new technologies. They help to deepen the knowledge of those responsible for implementation, thus preventing trivial mistakes, and they may serve as relatively cheap and reliable problem-solvers. In addition, this experience will help the university to act in a professional way and to translate its new experience in more appropriate technology transfer.

The absence of these facilities exerts without doubt a negative influence on the chances that a new – or even a proven – technology can be introduced successfully. If the waste water management sector is as such still a new concept to a country (like in some African and South-East Asian countries), the first two items mentioned above are predominant conditions for any progress. If waste water management is already a familiar concept in the country (like in most South American countries) and a new technology needs to be tried out, the third issue may take over in importance. It is considered that, in particular, the use of anaerobic treatment requires good technical and scientific backing from university laboratories with a record of successful research. The experience with the UASB plants in Colombia, Indonesia and India indicates that the deficient institutional supporting structure is a prime reason for the failure of a new technology.

5.5.5 The technical standards factor

It is often reported that technologies fail not because of process or conceptual deficiencies, but because the technical standards commonly applied by contractors and equipment suppliers are too low. In most cases a correlation exists between sub-standard work and low bidding prices, if such a low bid is accepted by the principal, physical defects will appear, leading to abnormal additional operation and maintenance costs.

In the case of the introduction of anaerobic treatment technology, contractors need to be more carefully selected. The construction of large concrete watertight tanks, grit channels, gas and sludge collection facilities, as well as the selection and installation of pumps, valves and other equipment are not commonly present with most contractors. The proper implementation of any other sanitary engineering facility, however, will require similar skills, and it is therefore in principle not so that anaerobic reactors impair a higher failure risk than a more conventional type of reactor. Even the construction of ponds and lagoons requires an experienced contractor, especially in areas with difficult soil conditions. The special considerations related to anaerobic treatment pertain mostly to selection of building materials and mechanical equipment that is to be corrosion proof and gas-tight.

5.5.6 Management aspects

It was concluded in *Section 5.3* that anaerobic reactors alone will often not meet effluent requirements and then need additional treatment. One treatment facility will thus consist of two subsequent processes, and its overall reliability will be partly defined by the second step. It is therefore difficult to compare single anaerobic plants with the (complete) conventional alternatives.

Nonetheless, it may be instructive to mention some fundamental characteristics of basically anaerobic and aerobic processes.

Anaerobic reactor technology has been applied successfully for industrial waste water treatment for over a decade already. The experience from this side is that if the plant is well-designed and operating, it requires relatively little supervision, however, if it is disturbed because of influent fluctuations, electro-mechanical failure or gradual development of poor sludge, considerable expertise is necessary for redressing the situation. If the reactor needs to be opened, major costs are incurred.

It may be expected that the smaller the community served by a reactor, the lower the level of supervision and the more likely the development of operational difficulties, like accumulation in the reactor of inert and clogging materials. However, there is reason to

believe that routine tasks and visual inspection can be carried out by less-skilled staff, actual supervision, control and trouble-shooting, however, must be carried out by an adequately developed organisation.

An important advantage of the aerobic alternatives is their excellent accessibility, allowing most maintenance whilst the plant is functioning. Active sludge can be stored unfed up to a week or two in aerobic conditions; anaerobic sludge can be stored for several months, on the other hand.

The better control that aerobic plants allow necessitates also better and more continuous process supervision than is the case with anaerobic treatment. It also involves more electro-mechanical equipment posing more risks for failure and requiring more routine maintenance. The processes involved in both types of plant are equally complicated, this would also be true for start-up operation.

Lagoons and ponds require minimal supervision provided they are well-designed; they show the largest resilience to any disturbances, need limited process control and electro-mechanical equipment, and may require regular maintenance of only the in- and outlet structures and of the embankments, as well as sludge removal every few years.

Experience of professionals, as available with consultants, university graduates, or publications, is far larger and much more comprehensive with regard to aerobic treatment than to anaerobic treatment. In many developing countries design and O & M procedures for conventional plants are nowadays well described and fairly standardized. Nevertheless, even in these countries a wide gap still appears between the "know-how" and the "do-how," a consequence probably of the lack of practical experience with waste water management in general. Experience with anaerobic treatment has not yet transpired to the professional community in industrialised countries, let alone in the developing countries (except for a few specific locations – usually related to industrial applications – in 3 or 4 countries, *i a* India, Colombia, Brazil and P.R. China (*Picture 8*)). It is therefore clear that anaerobic treatment poses an additional risk for failure, and that any implementation necessitates careful institutional preparation. *Picture 8* shows the application of anaerobic treatment of industrial waste water a remote area in the Philippines.

5.6 Economic and financial considerations

5.6.1 Costing procedures

This aspect will be approached by first identifying the cost components, and then collecting field data on construction costs, operation and maintenance (O & M)

costs, Total Annual Costs per Household (TACH), and eventually Net Present Values (NPV).

The basic instruments and procedures used to arrive at a correct economic and financial assessment of a given sanitation scheme are outlined in *Appendix 2*. Given the focus on the treatment process, and the implicit assumption that the society is willing to pay for an adequate level of service, the financial aspects are of less importance for a comparative analysis. The most useful form of analysis will be economic cost-effectiveness analysis focussing on the treatment system. The techniques used are TACH and capital costs per capita (population equivalent).

In the situation with predominantly on-site sanitation options, as discussed in *Chapter 4*, it is reasonable to assess the feasibility of anaerobic waste water treatment technologies by selecting representative urban areas as case studies, and carry out "mini" sanitation master plans under standardized conditions in which the choice of the treatment technology is a key variable. As concluded in *Chapter 4*, such plans will not drastically vary from one site to another. In the situation of off-site treatment, the economic costing of the complete waste water management scheme will on the contrary depend very much on local, unique conditions. Amongst the factors that prevent easy comparison between different alternatives on one location, as well as comparison of one alternative between different locations, can be mentioned: specific building regulations and requirements, *e g.* as defined by soil characteristics (need for piling, presence of rocky bottom or boulders, consequences of high or very low water table, slope of the terrain, degree of impermeability, risks for earthquakes, etc.), the presence of an operational sewerage network in the city, the availability of land near the city, legal constraints or possibilities for land acquisition, differences in unit costs, and so forth. Within one small region or country, like The Netherlands, it is possible to apply a more or less standardized costing approach which provides an acceptable basis for comparison. On a larger regional scale, however, it is impossible to devise a costing procedure that ensures the same degree of comparability.

A second limitation is the dependence of the economic feasibility of the treatment on available infrastructure or other opportunities. For example, a city may already operate a sewage collection and transportation system that conveys the sewage to a river or sea outfall. Any treatment constructed afterwards can benefit from the fact that this sewer line probably crosses areas with very low land prices, favouring treatment technologies that are land intensive, and, without this sewer, might have necessitated a very expensive sewage adduction system.

Given the poor relevance of one completely analysed set of off-site treatment alternatives for one location, it is instead preferred to collect data from various sources (different locations, different conditions, different costing procedures, etc) and deduce generalising conclusions in the form of **trends** from these.

As a consequence of the above, focus will be on the treatment systems and not on the collection systems. Cost information will be collected pertaining to comparable situations. In *Chapter 6* a brief calculation will be carried out involving sanitation programme alternatives to "connect" the urban area with the treatment facility, in order to evaluate the economic feasibility of intermediate-size township-scale anaerobic reactors, versus large off-site systems.

5.6.2 Relevant cost components

The discussion of the determinants in *Chapter 2* emphasized the comprehensive waste water management approach. Despite the limitations for comparable costing, it is useful to keep this approach in mind when interpreting cost figures. Generally speaking the waste water system can be functionally divided into 4 parts, each part divided into 4 major cost components (*Table 5.6*).

An important consequence of this approach is that it appears difficult to compare treatment alternatives with a different characteristic that has a marked influence on one of the other components in the table. This is, for example, the case when land-intensive and land-extensive treatment options, like ponds and UASBs respectively, are compared. Sufficiently cheap land may not be available near the city fringe. A cost comparison must then include the option of a land-extensive treatment plant (more expensive in con-

Table 5.6 Typical definition of main cost components of waste water management schemes, with exclusion of those relating to institutional management at the levels of the responsible authorities and the community, and to scientific support

Component	Investment			
	Land	Civil	Electro-mech	O & M
Sewage collection (house connections)	a	b	c	d
Sewage transport	e	f	g	h
Treatment plant	i	j	k	l
Sludge treatment and handling	m	n	o	p

struction and operation) requiring less space and shorter sewage transportation piping, as the plant is situated closer to the city, and that of a land-intensive pond system (cheaper in construction and operation) requiring more but cheaper space and a longer sewage transportation piping, as the plant lies farther away from the city.

As discussed in *Appendix 2*, the investment required contains considerable "other" sums related to activities that strictly speaking are not construction costs (traffic disruption during construction, costs incurred to secure loans, probable average costs caused by likelihood of failure). It is useful to divide the sewerage network in two parts: (i) secondary sewers, consisting of the house connections and smaller-bore sewage collection pipes, and (ii) the trunk sewers that convey the collected sewage over longer distances to the treatment plant.

5.6.3 Costs specific for anaerobic treatment technologies

Again, reliable field tested information is scarce and mostly pertains to studies with UASBs.

Table 5.7 compiles plain construction cost data for a number of UASB plants at 8 locations, 5 in South America, 2 in Asia and 1 in Europe. Some of these data are derived from feasibility studies and commercial offers (refs. 1, 3, 4, 6) whilst others are based on pilot-plant studies (refs. 2, 5 and 8). In addition, both the technical design framework (sewage composition and dynamics, reactor loading) and the costing framework (costing procedure, unit costs, exchange rate to US dollar) are not fully compatible with each other. Hence results are not completely comparable. Notwithstanding this limitation, it is felt that the order of magnitude of costs as expressed per Population Equivalent (cap, or PE), per m³ treated waste water, and per m³ reactor volume, is a useful tool. In the developing countries the cost per cap varies from US\$ 10 to 30, per m³ treated from US\$ 140 to 300, and per m³ reactor volume from US\$ 30 to 110. The ratio between the lowest and highest cost figure is approximately 3, a fair value given the wide situational differences. The costs for the European condition (The Netherlands) are convincingly higher (2 to 5 times the average in developing countries) as can be expected from higher unit costs and lower hydraulic loadings of the reactor due to lower temperature.

Reliable information on O & M costs is even more scarce, as up to now insufficient full-scale experience is available. As far as staffing is concerned, daily supervision and follow-up of a plant may

need to be continuous, because of the reactor characteristics described in *Section 5.4*;

- this supervision is of a more simple nature than what is required by conventional aerobic plants because of (i) reduced electro-mechanical equipment, (ii) less need for process control (sludge recycling, aeration, sludge settleability, etc.) and (iii) reduced quantities of excess sludge,
- in most cases the staffing requirements for the anaerobic plant will be relatively small. However, anaerobic plants are to be considered as pre-treatment. The post-treatment will usually require full-time attention and control which then can easily cover the plant's anaerobic part;
- plant supervisors need to be well-trained for routine activities, they must be backed by a team of more knowledgeable operators and engineers who are not stationed at the plant but can on short notice be called in and take remedial action;
- supervision is more intensive than for long-retention-time ponds.

Maintenance costs are proportional to the plant's construction cost. Maintenance costs will therefore be only marginally smaller in the case of anaerobic plants, anaerobic reactors comprise parts that are sensitive to wear and tear (gas collection, inlet pipes, sludge bleed valves, etc.). They will be considerably larger than in the case of ponds. Energy costs are in principle negligible, provided the soil condition allows the plant to be

constructed under ground level, a reactor requiring heights of 4 to 6 m.

5.6.4 Comparison of costs for treatment alternatives

a. Construction costs

More informative than determining the cost of anaerobic treatment plants at various sites is comparing them, at one site, with costs for alternative, conventional treatment. The conventional alternatives can be divided into two distinct categories: (i) high-rate aerobic technologies combining high construction and O & M costs with low land costs (activated sludge plants and trickling filters), and (ii) ponds combining (usually) low construction and O & M costs with relatively high land requirements. This division is also relevant in terms of treatment efficacy and efficiency, notably with respect to pathogens removal (see *Section 5.3*). Because of these cost considerations and the high process stability, ponds are commonly thought of as "appropriate" technologies for developing countries.

Table 5.8 compiles sets of construction cost data that are internally maximally comparable, as they are calculated by the same consultant for the same situation.

The conclusions from *Table 5.8* are:

1. Differences in costing procedure and situational data render quantitative comparison precarious, but

Table 5.7 Construction cost data for UASB reactors, complete with necessary equipment, pumping station (except Rada', Baranquilla, Bandung), grit removal and sludge drying (except Rada') Excludes land and contingencies

Location	Capacity (cap)	Construction cost (US\$) per			Reference
		cap	m ³ reactor	m ³ /d treated	
Rada', N-Yemen	46,000	-	181	137	1
Kanpur, India	41,000	6.3	486	52	2
Bucaramanga, Colombia	80,000	27	157	131	3
Cali Vivero, Colombia	16,000	22	425	106	4
Sao Paulo, Brazil	-	30	600	150	5
Baranquilla, Colombia	5,000	9	180	45	6
Bandung, Indonesia	2,500	25	-	-	7
The Netherlands	10,000	53	583	404	8
	100,000	47	528	366	8

1 = Euroconsult (1988)

2 = Haskoning (1990) based on experience with Kanpur demonstration-scale plant (unpubl.)

3 = DHV Consultants Fact sheet "Rio Frío, Bucaramanga, Colombia", undated, includes facultative pond with HRT = 24 h

4 = Haskoning (1987) (unpubl.)

5 = Vieira (1988)

6 = Incol (1988) (unpubl.)

7 = Own calculation based on simplified design of ref. 4

8 = Witteveen+Bos (1989) excludes pumping station, sludge handling and main piping. Another (less experienced) estimator gives prices 30 to 60% higher

Table 5.8 Sets of cost data for construction + land. The data are plain costs, and are not corrected as Net Present Values. Data from different sources can be compared only in a qualitative way since assumptions and/or local circumstances can be different.

Country	Treatment	Capacity (cap)	Cost (US\$/cap)	Reference
N-Yemen	Oxidation ditch	25,000	26	1a
	Stabilization ponds	25,000	29	1a
	Aerated lagoon	25,000	36	1a
	Trickling filter	25,000	45	1a
Asia, Jamaica, Africa	Anaer pond + fac.pond + mat.pond	diverse	38	1
	Aer lagoon + mat.pond	diverse	(44)	1
Israel	Stabilization ponds	diverse	11-18	1
	Ponds with partial aeration		27-32	1
	Aer.lagoon + polishing pond		50-55	1
Thailand	Aerated lagoons	89,000	11-15	2
	Stabilization ponds	89,000	11-19	2
	Activated sludge	89,000	50-50	2
N-Yemen	Oxidation ditch	46,000	52	3
	UASB + oxidation ditch	46,000	57	3
	Anaer pond + fac pond	46,000	84	3
Colombia	Fac pond	16,000	4	4
	UASB	16,000	4	4
	Oxidation ditch	16,000	17	4
Colombia	UASB + pond	80,000	26	5
Netherlands	Oxidation ditch	25,000	217	6
		50,000	175	6
		100,000	149	6
	Activated sludge	25,000	257	6
		50,000	194	6
		100,000	164	6
	Trickling filter	25,000	236	6
		50,000	176	6
		100,000	142	6
India	Activated sludge	3,000	38	7
		30,000	20	7
	Act sludge, incl. sludge digestion	41,000	13.8	8
	UASB + aerated pond	41,000	11.1	8
	UASB + cascade + settler	41,000	9.4	8
	Act.sludge, incl. sludge digestion	200,000	7.2	9
	Oxidation ditch	200,000	7.2	9
	UASB + act sludge	200,000	6.9	9

1a = Arthur (1983) Calculated case study prices for 1980. Effluent requirements: 25 mg BOD/L, 10,000 FC/100 ml.

1 = Arthur (1983) Field data, in 1979 prices. Varying effluent quality, net pond area: 1.2 ± 0.3 m²/cap, and 2-7 m²/cap, resp.

2 = Orth (1988) Calculated prices for the Chonburi case. The indicated range reflects sensitivity to doubling of land price.

3 = Euroconsult (1988). Effluent quality: 25 mg BOD/L.

4 = Haskoning *et al* (1985). Only simplified designs are compared. Effluent quality for the ditch: 20 mg BOD/L, for pond and UASB efficiency of 75% on BOD. Prices exclude main piping, pumping station.

5 = Jakma, Collazos and Schellinkhout (1987). Total efficiency on BOD 90%.

6 = STORA (1988). Effluent meets Dutch effluent standards. Plants are complete with sludge digestion and dewatering and are designed for specified nitrification. Excl. land cost.

7 = Arcevala (1989) (unpublished). Excl. land cost and all contingencies.

8 = Ganga Project Directorate, New Delhi (1989). Indicative calculation, based on experience of Kanpur demonstration plant (land cost 0.3-0.5 US\$/cap, depending on the alternative). Effluent at 30 mg BOD/L.

9 = Associated Industrial Consultants, Bombay (1989). Effluent at 20 mg BOD/L. Exclusive of land cost, pumping station and all contingencies.

allow to identify trends. Conversely, calculating for one illustrative case study may lead to conclusions that are not necessarily fully transferable to other situations. A definitive cost calculation for a given project should in any case be made separately taking into account all specific circumstances.

2. In some of the described cases oxidation ditches were a cheap solution as compared to the alternatives in the given set: in N-Yemen (in both cases), and in The Netherlands; in the case of the Colombia set, the oxidation ditch is more expensive, but delivers an effluent of much higher quality (on BOD) than its two competitors.

3. Economies of scale are apparent, notably in the case of The Netherlands. Cost differences between the three technologies are minimal.

4. The second N-Yemen case shows that the difference in construction costs between one large oxidation ditch and a UASB + small oxidation ditch to arrive at the same effluent quality is negligible.

5. Construction cost, including land purchase, is marginally more elevated for pond systems than for oxidation ditches, and by extrapolation for UASB + small oxidation ditch. This is in the second N-Yemen case more pronounced due to the porous soil, requiring special measures (lining) to prevent excessive leakage.

6. Most importantly, the recent comparative calculations for the two Indian cases (refs. 8 and 9), based on the new experience with a demonstration plant of the UASB type, clearly indicate that anaerobic treatment completed with post-treatment in order to achieve the prevailing sharp discharge standards is (BOD 20 mg/L, TSS 50 mg/L) significantly cheaper than fully aero-

bic alternatives.

7. In tropical climates anaerobic reactors can be kept small, leading to limited construction (and land purchase) costs.

b. Operation and maintenance cost

The construction cost (including land purchase), however, reflects only part of the total cost to build and use a treatment facility. O & M costs can be elevated and form considerable portions of the annual expenditures of a plant. O & M costs depend strongly on local conditions (e.g. labour and energy cost) as well as on the professionalism and service level strived for by the management.

Table 5.9 compiles recommended staffing levels for countries with cheap labour. Staffing requirements, however, may vary widely with country- and plant-specific conditions. In industrialised countries staffing level of aerobic plants is much lower: the plant is more automated (higher investment cost) and the staff better educated. Staffing level there (as normal man-years) typically varies from 1-2 for 25,000 cap installations to 2-3 for 50,000 and 3-4 for 100,000 cap plants (STORA, 1988).

As could be expected, staff size is larger for UASBs than for ponds. If anaerobic treatment is only a first step in a plant, the staffing specific for the UASB will become lower, but staffing level will become determined by the post-treatment (aerobic treatment or pond).

Vieira (1988) estimates annual O & M costs for Brazilian conditions at US\$ 0.40/cap.

Table 5.9 Recommended staffing levels for typical installations in areas where labour is relatively cheap (normal man-days per day). Figures should be seen as indicative and preliminary.

Plant	Plant engineer	Supervisor	Labourer ^a	Lab technician	Total
Stabilization ponds¹					
10,000 cap	0.2	0.2	2	0.2	2.4
25,000 cap	0.2	1	4	1	6
50,000 cap	0.2	3	6	1	10
100,000 cap	1	3	10	1	15
250,000 cap	1	3	17	2	23
UASB plant²					
10,000 cap	0.2	1	3	0.2	4.4
50,000 cap	1	5	10	1	17

¹ Adapted from Arthur (1983).

² Adapted from Haskoning (1989).

^a Regular assistance and supervision by senior staff must be provided by responsible government authority.

^b Includes watchman, driver, etc.

c. Net Present Value and Total Annual Cost

A way to incorporate O & M costs in one figure with construction and land purchase costs, and at the same time value the effect of the moment of expenditure, is to calculate the Net Present Value (NPV) (see *Appendix 2*). Another method is to calculate total annual costs, including depreciation of assets. The most accurate of both is, of course, NPV because it recognizes the time value of money. *Table 5.10* brings together sets of calculations performed for different locations and probably under slightly different calculation procedures; qualitative conclusions can be drawn

From this table the following tentative conclusions can be drawn.

1. The order of magnitude of the NPV values for similar plants are comparable in the different countries.
2. The oxidation ditch is the second cheapest option in

the first N-Yemen case, slightly more expensive than ponds; in the second N-Yemen case it is the most expensive of the considered options. Given its relative position, one may expect that options with "complete treatment" (effluent quality 30 or 20 mg/L BOD) involving use of anaerobic treatment (UASBs) lead to NPVs typically on the cheap side, comparable to those for ponds. The valuation results in the India case yield significant cost differences and are also strong evidence that, depending on a number of circumstances (notably land cost), either ponds or UASBs + post-treatment will be cheapest, and that both will be in many situations cheaper than trickling filters, oxidation ditches and activated sludge systems.

3. The NPV calculation further reinforces the advantage of anaerobic systems of being cheaper in capital cost (*Table 5.6*)

4. Based on NPV, trickling filters are marginally cheaper under Dutch conditions than activated sludge

Table 5.10 Sets of Net Present Values for construction, land purchase and O & M. The second case of N-Yemen pertains to a total annual cost (TAC). NPV does not take into account the possible resale value of the land after the plant life span. The more negative the cost figure, the more expensive the plant.

Country	Treatment	Capacity (cap)	Cost (US\$/cap)	Note
N-Yemen	Stabilization ponds	25,000	-206	1
	Oxidation ditch	25,000	-234	1
	Aerated lagoon	25,000	-301	1
	Trickling filter	25,000	-328	1
N-Yemen	Anaer pond+fac pond	46,000	TAC -8.63	2
	UASB+oxidation ditch	46,000	TAC -8.80	2
	Oxidation ditch	46,000	TAC -9.52	2
Netherlands	Trickling filter	25,000	-425	3
		50,000	-321	3
		100,000	-254	3
	Oxidation ditch	25,000	-425	3
		50,000	-365	3
		100,000	-314	3
	Activated sludge	25,000	-474	3
		50,000	-364	3
		100,000	-299	3
India	Act.sludge, incl. sludge digestion	41,000	-437	4
	UASB+aerated pond	41,000	-264	4
	UASB+cascade+settl.	41,000	-200	4

1 Arthur (1983) NPV includes income from resource recovery pisciculture and irrigation. Project life span 25 year, economic discount rate 12%. Land cost US\$ 5/m² favouring land intensive options (Desk study)

2 Euroconsult (1988) (Comm feas study)

3 STORA (1988). Exchange rate Hfl. 2 1/US\$. (Desk study)

4 Ganga Project Directorate, New Delhi (1989) Indicative calculation, based on experience of Kanpur demonstration plant (land cost 0.3-0.5 US\$/cap, depending on the alternative). Effluent at 30 mg BOD/L. Sludge and effluent are sold (at US\$ 3 3/ton and US\$ 0.01/m³, resp) but gas is not valorized (Comm. feas study)

and oxidation ditch plants. However, this difference is not of a decisive magnitude and does not allow generalization of this conclusion. It must be borne in mind that, contrary to common belief, the activated sludge plant has very low to zero energy costs, since primary and excess sludges are digested, and the recovered biogas is utilized in gas motors to produce electricity (integrated plant). Under conditions of most less-industrialised countries however, such integration may prove to be too sophisticated, making this aerobic option less economic.

Additional information on the relative position of anaerobic treatment in terms of NPV calculation can be drawn from a study carried out for Dutch conditions (Witteveen+Bos, 1988). This study treats all possible schemes in a standardized way. It presumes that the anaerobic step is to be followed by an aerobic one to attain complete treatment, i.e. BOD < 20 mg/L and > 75% nitrification in the case of the low-loaded oxidation ditch alternative for 10,000 cap, and 10-30% nitrification in the other cases (no phosphate or pathogen removal). The study also performs sensitivity analyses on acceptable volumetric loading rates of the anaerobic reactor, construction costs, amount of N removed in the anaerobic reactor, sludge loading rate in the post-treatment, and sludge disposal alternatives. A selection of the results is shown in Table 5.11

Table 5.11 shows that the application of UASBs in moderate climates provides, at the present state of knowledge, a reasonable advantage of around 5% in the case of the smaller plants where oxidation ditches

are likely to be selected. The anaerobic-based option has lower operational costs. For mid- and larger-sized plants, of 50,000-100,000 cap, the UASB application is more expensive by 10 to 20% under the given conditions. If final effluent of the 50,000 and 100,000 cap plants has to meet the requirement of 75% nitrification (oxidation of Kjeldahl-nitrogen), NPVs are 10-20% above those for plants without this pronounced nitrification. In the case that excess sludge cannot be disposed of in agriculture or by dumping, but needs to be incinerated, the economic feasibility of the anaerobic-based option improves drastically, and it may become more attractive in most cases than the reference scheme. This, however, though soon a reality in industrialised countries, may be less realistic in developing countries.

The good performance of the activated sludge scheme is related to the in-plant power generation from biogas from the sludge digesters. Such integration requires a high degree of sophistication that is less appropriate for developing countries. If no sludge digestion takes place, the balance shifts in the favour of the UASB scheme with up to 5% saving in NPV as compared to the reference. A second beneficial effect for developing countries is a higher ambient temperature and thus a shorter hydraulic retention times of app 6 h (see Table 3.4). If this value is introduced instead of the 8 h, saving in NPV becomes marginally positive (0 to 2%) for the case of The Netherlands.

Concludingly, UASB based treatment achieving effluent quality of 20 to 30 mg/L is usually economical

Table 5.11 NPV cost difference between (complete) treatment schemes incorporating UASB, and a reference scheme; expressed as percentage higher (-) or lower (+) cost of the UASB-based scheme (Witteveen+Bos, 1989). Valid for The Netherlands. Indicated are ranges with different options w.r.t. design criteria and in unit costs, negative values imply that the UASB scheme is more expensive than its reference.

Plant (cap)	Investment NPV	O&M NPV	Total NPV
	(UASB + oxidation ditch) vs (reference: oxidation ditch)		
10,000	-8.6 to -12.5	26.5 to 26.1	6.7 to 4.3
	(UASB + activated sludge) vs (reference: activated sludge)		
50,000	-9.2 to -21.7	-4.7 to -9.7	-7 to -18
	(UASB + activated sludge) vs (reference: activated sludge)		
100,000	1.8 to -10.7	3.6 to -4.6	-8.8 to -21.8

Assumptions

- Avg hydraulic retention time UASB = 8 h

Sludge is disposed of in agriculture

UASB removes 0-20% N

Sludge loading in oxidation ditch 0.05 and in act. sludge 0.15 kg BOD/(kg MLSS.d)

Project life span 30 year but electro-mechanical part depreciated in 15 year; financial discount rate 8%, annual inflation 5 but for energy 9%

in tropical countries, but not or only marginally cheaper in industrialised countries with temperate climate.

The scarcely available pilot-plant data on other anaerobic reactor types indicate that they probably do not perform better (in terms of removal efficiencies at a given hydraulic retention time) than UASBs (Table 3.2). On the contrary they may be more expensive than UASBs; this holds particularly true for anaerobic filters that are filled with plastic filter material, which adds considerably to total cost.

In the above calculations two important numerical values had to be assumed with decisive influence on the economic feasibility: for land cost, and for discount rate. The sensitivity of results to land cost will be further discussed hereunder

d. The influence of land cost

The land cost has an obvious impact on feasibilities. As suggested in Table 5.6, any realistic feasibility study will include all costs related to the full sewage scheme, including the sewerage. Of course, if sewerage and sewage transportation pipes are already available and only a new treatment plant has to be erected, then the feasibility study can limit itself to evaluating only the additional costs related to the new plant. For a new scheme however, an optimization has to be carried out: if the treatment is located close to the city where the waste is produced, land costs are high but the sewage transportation lines are short and thus cheap; conversely, if the treatment facility lies far away from the city, land costs are low but sewage transportation costs high. High land costs favour high-rate technologies like aerobic treatment and UASBs; low land costs favour ponds and lagoons. This is illustrated by Figure 5.2, in which the typical perform-

ance of treatment technologies is expressed as a function of the hydraulic retention time (which can be considered as an indication of land use)

Two situations may be distinguished:

- (i) land cost decreases only slowly as a function of distance to the city centre, and land below a critical cost level is available too far from the city to allow affordable sewage transportation (for instance around metropolises and sprawling urbanised areas like the Jakarta-Bogor-Tangerang-Bekasi area in Indonesia, Bombay area in India, Randstad in The Netherlands, etc.); in this case land consuming treatment facilities are unfeasible;
- (ii) land cost decreases sharply as a function of distance to the city centre, and cheap land is available sufficiently close to the city's edge (for instance as is the case with many towns at a reasonable distance from other urban areas); in this case land consuming treatment may be most feasible

To complicate the calculation, it can be argued that the NPV should include the resale value of the land after the plant's lifespan. If this is done, vast ponds achieve low NPVs, as it is common that land near the city appreciates in 20-30 years 20-50 times, this is at a rate considerably higher than the discount rate (real land price increases of 5.8 to 8.6% per annum were found, for instance, in 4 representative suburbs of Bangkok [Chantana, 1987]). In a way, the waste water treatment plant functions for the city government as an investment in real estate. However, if this resale value is discounted and included in the NPV, the cost for its replacement at another site, including higher transportation costs, should also be taken into account. It is obvious that such complete calculation becomes pre-

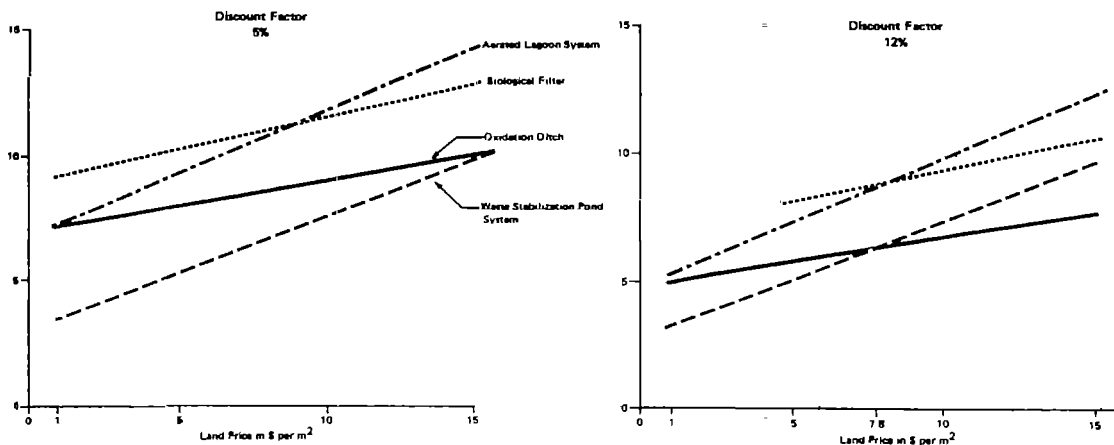

Figure 5.6 Influence of land price and discount factor on Net Present Value of treatment alternatives for Sana'a, N-Yemen (Arthur, 1983).

carious as it involves many unknowns. Therefore, this line of thought is not further pursued here.

The influence of land cost is shown in *Figure 5.6* for the calculated examples of Sana'a, N-Yemen (Arthur, 1983). At a discount rate of 5% the oxidation ditch becomes cheaper than the waste stabilization pond if land price exceeds US\$ 15/m². If the discount rate is 12%, the break-even point lies at US\$ 7.8/m². For practical purposes and in most cases, 10 to 12% should be considered an appropriate economic discount rate; 5% is on the low side. The typical figures for land prices as applied by Arthur in 1979 can still be considered pertinent; land price will have risen since then but for the land categories involved the order of magnitude will not have changed. Thus, one can provisionally conclude that a pond system becomes cheaper than an oxidation ditch when land price falls below US\$ 5-10/m².

Based on the conclusion from *Table 5.9* that one may expect a UASB + post-treatment to be cheaper in NPV than an oxidation ditch, it is likely that the break-even land price is still lower if ponds are compared to UASB + post-treatment, possibly ranging between US\$ 4 and 8/m².

As already argued in *Section 5.5.2*, this way of comparing land-intensive and land-extensive treatment alternatives can be questioned. Cheap land, a prerequisite for land-intensive options, is usually available only farther away from the place of origin of the sewage, thus leading to higher sewage transportation costs. If this effect is also taken into consideration, the break-even land price will in many cases be further

lowered, rendering high-rate alternatives like UASBs even more attractive.

Table 5.12 compiles 1988/1989 figures for land prices, in order to facilitate comparison with the break-even values deduced by Arthur.

The real price of land is sometimes difficult to precisely assess, as expropriation procedures vary from country to country. Also, some countries, like Tanzania, do not fully recognize the opportunity cost of land, insisting that all land is owned by the government. The price a plot of land commands varies greatly with location, accessibility, size and shape, and surroundings.

Notwithstanding this constraint, the above figures clearly indicate that the critical values of US\$ 4 to 8 per m² are certainly on the low side for urban or semi-urban fringe areas. Even for the rural edge areas around the cities mentioned in *Table 5.11*, land prices may often exceed the threshold cost. Exceptions to this rule are plots that have little intrinsic value, for example marshy areas near a city or a seashore. Also, it may be readily assumed that the rural edge of medium- and small-size towns is more likely to yield the low land prices necessary for land-intensive treatment systems.

e. The influence of the discount factor

The second important variable is the discount rate. Economic discount rates vary from 5 to over 15%, depending on how the country values its growth opportunities. The financial discount rate reflects the

Table 5.12 Land prices (1988/1989) expressed as US\$/m²

Location	City centre	Around centre	Urban edge	Rural edge
Indonesia: Jakarta	> 300	200-300	50-200	< 50
Bogor	200	125	50	5-10
Yogyakarta	75	50	25	15
Bandung	> 120	60-120	20-45	6-25
Ambon	100	75	25	< 5
Thailand: Bangkok ¹	-	> 300	25-150	10-40
medium size cities ²	50-150	-	-	5-20
Turkey: Istanbul	150-200	50-75	20-35	10-15
India: Hyderabad	200-500	150-200	50-10	10-30
Agra	80	40	20	1-5
Kenya: Nakuru	45	40	35	15

¹ Chantana (1987)

² Sinclair Knight and Partners (1989)

Other data collected via questionnaires.

opportunity costs for capital in a given country, and needs to be corrected for inflation; 2 to 4% are common values. In *Figure 5.6* the NPV is assessed on its sensitivity towards the economic discount rate. It appears that the effect of a variation from 5 to 12% has seemingly a minor effect, much less than the effect of land price. However, changing of the rate shifts the break-even land price into a critical range.

The applied discount rate in fact attributes a value to future expenses and income. A low rate gives great weight to the future transactions; a high rate does the opposite. In terms of O & M expenses, aerobic technologies rank higher than anaerobic ones and ponds. A low discount rate thus favours ponds and anaerobic technologies; a high rate renders aerobic plants more advantageous.

5.7 Biogas: a realistic perspective?

The generation of biogas is generally considered a major asset of anaerobic waste water treatment. This consideration is certainly true for anaerobic digestion of sludges, and for the treatment of "strong" industrial waste water, containing more than 2,000 mg COD/L. The quantity of biogas depends linearly on the amount of carbonaceous matter (BOD or COD) removed. C from hydrocarbons, proteins, etc. is after the fermentative reactions incorporated in the CO₂ and CH₄ which emerge in gaseous form. The biogas derives its energetic content from the CH₄; the CO₂, making up 10 to 20% of the biogas, increases the efficiency of the CH₄ burning process as it is a better heat conductor than CH₄.

The financial feasibility of anaerobic treatment is demonstrated in the case of, for example, an alcohol distillery with prices representative for Indian conditions, of which some 500 can be found in tropical countries around the world.

– a distillery of average size produces 500 HL alcohol (@ 96%) daily, and continuously discharges 600 m³/d x 90 kg COD/m³ = 54,000 kg COD/d.

Of this load, 75% can be removed anaerobically, the calorific value and fuel equivalence benefit can be calculated to be
(54,000 kg COD/d x 0.75 x 0.3 Nm³ CH₄/kg CODremoved) x 0.84 L fuel/Nm³ CH₄ x US\$ 0.23/L fuel x 330 d/yr = US\$ 0.76 million/yr

The related investment amounts to approx. US\$ 0.9 million. This investment is thus recovered in 1.5 to, under pessimistic circumstances, 2.5 years

If the same waste water were to be treated aerobically, the sheer recurrent cost of aeration energy is already prohibitively elevated.

assuming that on the average 1,000 kWh is required

for aeration to remove 1,000 kg COD, then the annual electricity bill is

54,000 kg COD/d x 0.75 x US\$ 0.04/kWh x 330 d/yr = US\$ 534,600

However, in the case of sewage the picture is less encouraging. Firstly, we deal with "weak" waste water with a COD content of 400 to 800 mg/L that consequently can produce only small amounts of CH₄. In addition, CH₄ is partly soluble in water; at the given concentrations this effect is noticeable with 25-65% remaining dissolved. Thirdly, the financial feasibility strongly depends on the local opportunity cost of energy contrary to most industries who have boiler houses to meet their heat requirements, usually no large institutional gas consumers are available in the sewage plant's neighbourhood, and the biogas becomes no asset but a liability since it is highly explosive.

The energy in the gas can be used in following ways.

– the gas is burnt in a boiler. The heated water and/or steam is utilized in a factory, hospital or other institution that has a constant need. The financial feasibility of the gas utilization critically depends on the continuity and stability of consumption, and on the question whether gas producer and consumer match each other's needs for longer periods. Each hour of the day, or week in the year that this is not the case will negatively affect feasibility. As example of such coupling, the biogas delivered from the sludge digestion at the Bombay Dadar treatment plant to a nearby hospital can be mentioned; however, the hospital does not need the gas continuously and does not appreciate either the regular shut-downs of the sludge digester for maintenance, rendering the investment in the piping and gas utilization equipment uneconomical,

– the gas is sold to households via a complex piping system. This option hurts on the cost of gas compressors, piping, safety equipment and house connection costs. Gas production fluctuates with the COD-load entering the plant; gas consumption follows a typical diurnal pattern. This implies that expensive gas storage tanks have to be provided. Extensive safety precautions are mandatory. Also, continuous gas supply cannot be guaranteed. A scope for "low cost" biogas consumption can exist in more rural areas with less densely populated settlements.

– the gas can be converted on-site into electricity with gas motors. Despite the poor conversion efficiency (20-26%) and the costs involved for the motor itself, the gas conditioning, and the O & M, this option is attractive. The electricity can be utilized in-plant, e.g. to power aerators in an aerobic post-treatment,

or to power pumps or other equipment. Nonetheless, this electricity may in many less-industrialised countries prove to be not much cheaper than electricity bought from the grid. An example where this approach is tried out on demonstration scale is found in Lucknow (India) where sewage is flocculated with alum and the settled sludge digested in order to power pumps that lift city drainage water over the dyke into the Yamuna River. The economic feasibility of such a scheme, however, is not obvious.

Sewage is reported to generate in Cali $0.19 \text{ m}^3 \text{ CH}_4/\text{kg}$ COD removed at 25°C and a height of app. 800 m above sea level (Haskoning, AUW and Emcali, 1989). This corresponds to $0.16 \text{ Nm}^3 \text{ CH}_4/\text{kg}$ COD removed. It is a low figure due to the fact that 25-65% of it remains dissolved. At the Bergambacht site and in Sao Paulo similar values were found, ranging between 0.13 and $0.19 \text{ Nm}^3/\text{kg}$ COD removed. At the Kanpur plant only app. $0.10 \text{ Nm}^3/\text{kg}$ COD removed could be recovered, probably because of considerable sulphate reduction taking place in this particular sewage. Theoretical conversion is $0.34 \text{ Nm}^3 \text{ CH}_4/\text{kg}$ COD removed.

How much energy can be derived from a sizable anaerobic treatment plant of, for instance, 100,000 cap? Assuming COD load entering the plant is, including organic solids, $0.6 \text{ kg COD/m}^3 \times 0.12 \text{ m}^3/\text{d} \cdot \text{cap} \times 10^5 \text{ cap} = 7,200 \text{ kg COD/d}$; with removal efficiency at 65% and above gas production rate. $7,200 \text{ kg COD/d} \times 0.65 \times 0.16 \text{ Nm}^3/\text{kg}$ COD removed = $749 \text{ Nm}^3 \text{ CH}_4/\text{d}$, or $749 \text{ Nm}^3 \text{ CH}_4/\text{d} \times 35 \text{ MJ/Nm}^3 \text{ CH}_4 \times 0.25 = 6,552 \text{ MJ(electric)/d}$ corresponding to $6,552 \times 10^6 \text{ J/d} \times 2.78 \times 10^{-7} = 1,821 \text{ kWh/d}$,

or, at a representative unit price $1,821 \text{ kWh/d} \times \text{US\$ } 0.1/\text{kWh} \times 330 \text{ d/yr} = \text{US\$ } 60,000/\text{yr}$

This would require installation of a gas motor with generator of app. 100 kW power with an indicative purchase price (installed but without civil work, cabling, gas piping, gas conditioning and appurtenances) of US\$ 50,000 (1989 price). In many less-industrialised countries the investment figure may be 10-30% lower, which, also thanks to cheaper labour, enhances the feasibility.

This example, with representative and "unpolished" values, shows that particularly in countries with expensive electricity, or irregular or otherwise constrained power supply, biogas utilization via power production is financially attractive in the case of large treatment works. The complete related investment can be paid off in less than 2 year. However, it will never provide the decisive argument in favour of anaerobic technology, though it is acknowledged that it assists in resource recovery.

For treatment plants of 50,000 cap or smaller the investment costs become proportionally heavier. In general it is not advised to distribute and utilize biogas at household level in so-called cheap or low cost options since the economic benefit is nil or marginal whilst safety is put at serious risk. An exception to this advice may be formed by the rural biogas schemes based on manure digestion where even small amounts of biogas contribute significantly to comfort, development and wood conservation. Many such schemes are reported to have failed, but successful ones exist in India, P R China, Nepal, Taiwan, etc.

This financial advantage was not taken into account in Section 5.4, but it is not expected that it will have a noticeable effect on the rankings.



6 The Position of Anaerobic Treatment in Waste Water Management Schemes

This Chapter will discuss which additional treatment (post-treatment) can be proposed to render anaerobic reactors part of a "complete" treatment plant, and under which circumstances and in which waste water management programmes anaerobic reactors can provide attractive solutions at on-site, off-site or intermediate scale.

6.1 Post-treatment options

6.1.1 Needs and opportunities

As was argued in *Section 2.5.1* it is for less-industrialised countries best policy to design treatment schemes under the assumption that eventually fairly stringent discharge standards will be imposed (see *Table 2.6*). From *Chapter 5* it can be concluded that the weak points in the performance of a single anaerobic reactor reside in its (i) good but still insufficient removal of BOD and COD, (ii) zero nitrification, producing an effluent with readily oxidizable ammonia (iii) poor removal of pathogenic viruses, bacteria, protozoae and amoebae, and (iv) relatively wide scatter on effluent quality characteristics. However, the alternative treatment options are not always nor on all counts performing better, and in many cases it appears that these were definitely more expensive. Attaching post-treatment to the anaerobic reactor could solve (part of) above limitations at competitive cost.

This circumstance provides an interesting advantage to anaerobic treatment because it allows phased investment. In such a complete plant the anaerobic reactor is the first and major item, responsible for the larger part of the overall treatment performance. This is in contrast to the situation with conventional aerobic treatment, where the second treatment step (the biological treatment) is most important. This means that anaerobic-based plants allow achievement of three-quarters of an eventual "complete" treatment performance by investing first in this first phase and in due time completing it with post-treatment. Aerobic plants do not allow this flexibility in investment schedule, since investment in the primary sedimentation is comparatively small and leads to limited result. The two-phase aerobic plants (A-B plants) do not possess this facility either, as their (attractive) economic feasibility is based on sludge digestion resulting from a

complete plant. Only ponds or lagoons would provide the same facility.

6.1.2 Simple aeration

Depending on the soil characteristics and other economic considerations, the reactor will be constructed above or under ground level. If it is constructed above ground level, sewage will have to be pumped to the waste water inlet/distribution boxes on top of the reactor. After passage through the reactor the water flows over the outlet weirs at a height of 4 to 6 m above ground level. This potential energy can be used to have the water sprinkled out and trickling down an open wooden structure, or in a cascade. The falling droplets strive for equilibrium with the surrounding air, and **desorb** dissolved gases, like ammonia, hydrogen sulphide and more complex gaseous constituents, and **absorb** oxygen. The desorption leads to a reduction of oxygen consumption in any subsequent biological oxidation (as takes place e.g. in a natural way in the receiving water body). It is presently still impossible to quantify this effect precisely, but it can be assumed that a few percentages of BOD are removed this way. The amount of oxygen absorbed can be calculated to be 1.5-4 mg O₂/L, depending on spray height, temperature and geometric variables. The combined effect thus leads to a reduction of the subsequent oxygenation requirement of 5-10%, in an easy-to-construct aeration tower at a relatively small cost. The construction would involve a number of water distribution pipes with spraying slots on top of a wooden open structure which rests on a flat concrete collection floor, operation and maintenance are minimal.

The obvious disadvantage of aeration is possible odour nuisance. According to the experience with demonstration plants, odour nuisance remains limited if the reactor effluent is stirred unnecessarily, it is probable that effluent aeration will necessitate measures to collect and treat (or dispose of through a high stack) the exhaust gases.

6.1.3 Biological post-treatment: activated sludge, oxidation ditch

If the anaerobic reactor is constructed under ground level, post-treatment could consist of an activated sludge or oxidation ditch system. Given the preference for more simple and reliable technology, the

oxidation ditch seems most advisable, as it is a low-rate and not-too-complex system; it has the additional advantages of (i) low production of excess sludge which is stabilized, and (ii) relatively large reactor volume and low sludge loading, thus flattening off variations in the effluent quality of the anaerobic reactor.

The oxidation ditch also provides full nitrification of the effluent (all ammonia oxidized into nitrate) which is positive in an environmental protection strategy. The ammonia is the major oxygen consuming constituent in the anaerobic effluent and thus determines the size (and cost) of the post-treatment. In the following example the required brutto oxygen demand (taking into account all efficiency losses related to mechanical aeration) is calculated for the case of zero and full nitrification in a plant for a population of 100,000. Assumed Population Equivalent values are 50 g BOD/cap.d and 10 g Kjeldahl-N/cap.d, the anaerobic reactor is assumed to remove 75% (a high estimate) of incoming BOD and to convert all Kjeldahl-N into ammonia

– Zero nitrification, in a high-loaded activated sludge system: brutto oxygen adduction required is¹ $0.05 \text{ kg BOD/cap.d} \times 0.25 \times 0.9 \text{ kg O}_2/\text{kg BOD} \times 1.75 \times 100,000 \text{ cap} = 2,000 \text{ kg O}_2/\text{d}$, this involves an energy consumption of $2,000 \text{ kg O}_2/\text{d} \times 0.67 \text{ kWh/kg O}_2 = 1,340 \text{ kWh/d}$.

– Full nitrification and sludge stabilization, in a low-loaded oxidation ditch:

brutto oxygen adduction required is $[0.05 \text{ kg BOD/cap.d} \times 0.25 \times 1.2 \text{ kg O}_2/\text{kg BOD} + 0.01 \text{ kgN/cap.d} \times 5 \text{ kg O}_2/\text{kg N}] \times 2.8 \times 100,000 \text{ cap} = 18,200 \text{ kg O}_2/\text{d}$; this involves an energy consumption of $18,200 \text{ kg O}_2/\text{d} \times 0.67 \text{ kWh/kg O}_2 = 12,000 \text{ kWh/d}$.

When comparing these energy consumption figures with the expected energy production (see example for the same plant size in Section 5.9), it appears that the high-loaded activated sludge system has the advantage of consuming only a little less than the electric energy produced by the anaerobic reactor. The technically and environmentally most appealing option, the oxidation ditch as post-treatment, consumes several times more energy than the reactor can provide.

The related capital investments for these two alternatives are not necessarily in the same proportion as

their energy consumption. Total costs expressed as NPVs were calculated for similar situations in Section 5.6.4 c, where the predominant importance of the nitrification was already made apparent. Also, excess sludge from activated sludge systems needs further aerobic or anaerobic digestion, both options add to cost and operational complexity rendering them possibly less attractive in less-industrialised countries.

Concluding, for any selection it is mandatory to identify the priorities a treatment scheme has to fulfill (assuming warm climate and conditions of less-industrialised countries).

– if no need for nitrification exists, the plant size is above 100,000 cap, and sufficient engineering experience is available to manage a complex plant, a UASB + activated sludge plant with sludge digestion is advisable (provided it proves more feasible than the fully aerobic option);

– if nitrification is required, large plants (> 100,000 cap) may benefit from the UASB + activated sludge option but the UASB + oxidation ditch is a feasible competitor, smaller plants (> 50,000 cap) will need the UASB + oxidation ditch (provided in both cases they prove more feasible than the fully aerobic option),

– if no need for nitrification exists and plant size is $\leq 100,000$ cap, the UASB + oxidation ditch is still most likely the feasible option because of the sludge problem (provided it proves more feasible than the fully aerobic option and an option involving ponds).

Insufficient experience exists with respect to the possible simultaneous digestion inside the anaerobic reactor of the excess sludge from the aerobic treatment. The UASB reactor type could in principle accept this sludge, reactor types with a filter material may be prone to clogging. A major possible difficulty would be a too poor settleability of the sludge causing excessive wash-out of particulate matter.

6.1.4 Biological post-treatment: trickling filter

If the reactor is constructed above ground level, the available head in the overflowing effluent can be used to have it trickle down in an aerobic trickling filter (height 3 to 6 m). The trickling filter has the advantage of not necessitating mechanical aeration.

When a trickling filter treats sewage, the fast biomass growth on the filter medium must be kept in check to avoid clogging, this is done by having the filter's effluent settled in a small settling tank (equipped with sludge raking bridge) and recirculating the effluent over the filter, thus increasing the hydraulic scour. For the filter to function at a reduced efficiency (40-50% on BOD) such settling tank with its appurte-

¹ Assumptions: 0.25 is the remaining fraction of the BOD load in the effluent, if the reactor has an efficiency of 75%. In the first calculation 1.75 is the required over-oxygenation capacity in order to provide the stoichiometrically needed 0.9 kg O₂/kg BOD, in the second calculation this figure is higher (2.8) because of the long hydraulic retention times involved.

nances may not be necessary, this would render the system more appropriate for smaller plants in less-industrialised countries. However, little is known about how such a filter behaves when it is fed with the UASB effluent which is highly reduced and carries a BOD concentration of typically 30-70 mg/L, well below that of common sewage. In warm climates, a single pass through the filter may, depending on volumetric loading rate, consistently allow removal of 20-40 mg BOD/L plus a fair degree (50%) of nitrification without biomass growth exceeding the scouring capacity of the nominal flow rate. At any rate, the filter will have to be carefully designed to combine both objectives

Also here odour problems may arise. Finally, the trickling filter produces an unstabilized sludge which needs further treatment. Similar considerations, as with activated sludge systems, are valid here.

6.1.5 Ponds

If land price permits, the anaerobic effluent can be "polished" in a facultative pond. Such a pond would remove the excess amounts of BOD, oxidize ammonium, and mineralize on its bottom any sludge settled. Accumulated sludge needs to be removed only once every two years. In view of the large volume it contains, it will also help to level off the peaks in the anaerobic effluent; these are often related to wash-out of sludge, which can readily settle in the polishing pond. As is the case with the oxidation ditch, the pond will have to be designed on its Kjeldahl-N load. Retention times will be at least 1 day.

Ponds or channels with floating aquatic macrophytes can also be considered for post-treatment. Their particular benefit relates to the pronounced removal of the nutrients (P and N) by the microbes associated with the macrophytes. The advised retention time is then not lower than 7 days.

If the eventual objective is also to induce sufficient pathogen removal, a series of 2 to 3 ponds with total retention time of 20-25 days will be necessary, as bacterial and viral decay is primarily dependent on total retention time. In this case the insertion of the UASB in the treatment scheme serves no purpose.

6.1.6 Other options

Other options include, for example, rotating (aerobic) biological discs and the rope contactor. The discs have the reputation of being user-friendly, reliable, simple in operation and construction, and thus appropriate for less-industrialised countries. Nonetheless, the available experience is relatively limited, and often pertaining to small pilot-plants. It is even more limited in the case of the rope contactor (recently developed by

NEERI, Nagpur, India).

Although it is acknowledged that these alternatives hold considerable potential, it is felt that conclusions would not deviate much from those pertaining to other attached growth reactors like trickling filters.

6.2 Anaerobic reactors in waste water management schemes

6.2.1 Centralised off-site option, Common sewerage

The usual situation one encounters is location of the treatment facility as close as possible to the discharge point (in river, lake, estuary or sea); this discharge point, of course, is to be located not too far from the city where the waste is produced. The plant is conceived to accommodate as much of the city's waste water as possible in order to make use of the economy of scale, and the higher quality of centralised operation and surveillance.

The application of high-rate anaerobic treatment has no particular consequences for the overall scheme and the related costs. The sewage needs to be adducted in a regular sewerage system.

6.2.2 Decentralised off-site option

a. Multiple discharge points

Anaerobic reactors, notably UASBs, allow for decentralised erection: since the UASB itself has relatively few moving parts, is fairly simple in construction and operation, and consumes little space, the economy of scale is less pronounced. The advantage of this decentralisation must then be found in lower costs incurred in the construction and/or operation of the sewerage. However, removal efficiency of UASBs on oxygen-consuming substances like BOD and Kjeldahl-N, is, generally speaking, too low to warrant direct discharge of the anaerobic effluent. A scheme which envisages, for example, separate treatment of the sewage of parts of the city ("townships") and leading the effluents to the receiving river along separate discharge lines is likely to hurt on the fact that post-treatment will eventually be required (*Figure 6.1*). As provision of post-treatment increases the plant's complexity as well as the total need for land, centralisation becomes again more advantageous. An exception to this statement is the situation where between city border and receiving water sufficient and cheap land is available to allow provision of small polishing ponds.

However, in two specific cases decentralisation may open up interesting perspectives. These will be discussed hereunder.

b. Decentralised UASBs at "township"-level as pre-treatment (Case b)

Particularly in the larger cities, the sewage transportation system may turn out to be expensive as a consequence of the fact that the sewage, which has to be conveyed over long distances, carries a load of organic material and grit which tends to settle in the sewer. This accumulating sludge may cause serious blockage problems and hence capacity reduction of the sewer pipes. In order to flush this sludge, the maximum water velocity in the sewer should regularly exceed the so-called scouring velocity; this can be attained by designing the sewer at a relatively steep slope. This implies deep trenches, more frequent intermediate pumping stations, and hence much higher costs.

An alternative that merits further study is to pretreat the raw sewage locally, removing all settleable material. The effluent can then be transported through cheaper trunk sewers that are less sloping (laid as shallow sewer) and may need manholes for maintenance at less frequent intervals as it is likely that if clogging occurs it will be caused by material that is easier to remove.

Figure 6.2a depicts the typical exemplary situation which is used here to carry out a tentative calculation of construction costs involved in such an option. Each sector with houses (township, comparable to, for example, the Indonesian *kampung*) is served by shallow sewerage bringing the sewage to a small plant consisting of a degritting channel and a UASB. This plant can be located on a small plot of land on a corner of the sector: it contains a house for the plant caretaker and there may also be a sludge-drying bed provided.

The effluent is partially treated, is clearer, does not contain (much) settleable matter, and is safer in terms of pathogens concentration (helminth ova are removed to a certain extent). It is converted in a form more appropriate for further conveyance. In addition, the collected sludge goes through a stabilization process in the anaerobic reactor, making it easier to handle it as well. The overall BOD removal efficiency achieved within the system, *i.e.* before the optional post-treatment outside the city, can amount to 70-80%.

This degree of decentralisation can only be achieved by a compact anaerobic reactor, like a UASB. It is assumed that odour nuisance is limited

The cost estimation for the waste transportation and local treatment part (thus excluding the optional centralised off-site post-treatment) is given in Table 6.1. The sanitation programme consists of the sewage collection within the township, its local treatment and its further conveyance to a place outside the city. The basic design assumptions for the conveyance used here are.

- (i) sewage collection (from household to local UASB):
- average area served per sector: 300 m x 300 m = 9 ha,
 - population served per sector: [200 to 250 cap/ha] x 9 ha = 1,800 to 2,250 cap;
 - raw sewage collecting sewer: max. length 200 m, slope 1 : 175, pipe diameter 20 cm (to allow manual cleaning), average excavation depth 1.5 m,
 - sewage (grey waste water) production: 50 L/cap d, peak factor 2;
 - number of households (hh) per sector: 250 to 320;

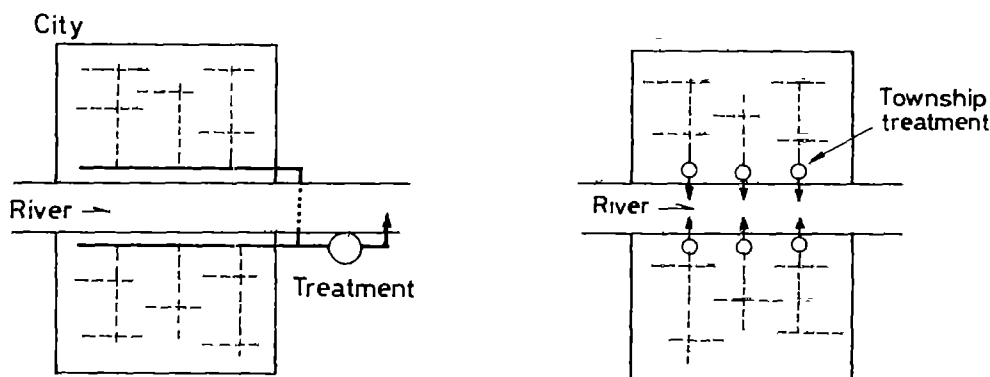

Figure 6.1 Two approaches to locate sewage treatment plants. In the conventional centralised option (left) the choice of treatment technology is not decisive. The decentralised option (right) could avoid substantial sewerage construction, but requires relatively small, easy-to-operate type of technology, the UASB or similar anaerobic treatment may qualify for this.

(ii) pre-treated sewage transportation (from local UASB to centralised post-treatment):

- number of sectors (townships) in city 20,
- trunk sewer: length 3 km, slope 4.2 to 1.2‰, pipe diameter 0.15 to 0.35 m, average excavation depth 5.4 m, but depth varies from 1.5 to 9.3 m, assuming level area.

The cost estimate is given in *Table 6.1*.

c. Decentralised pre-treatment in shared UASBs, sewer option (Case c)

A second alternative way of "conditioning" the raw sewage, or at least its black waste water component, is to collect via shallow sewers either the grey or the black waste water in shared underground reactors of small size, in a setting comparable to the **Cimindi** set-up (see *Section 3.5.1*). Again the overflow is drained via a sewerage system of a simplified design as no or few settleable solids are to be carried through this sewerage. This degree of decentralisation can only be achieved by a compact anaerobic reactor like the UASB. The BOD removal efficiency achieved within the system could attain 60-70%. It is assumed that odour nuisance is limited.

The typical "formalised" case area used for the cost calculation here is depicted in *Figure 6.2b*. The design basis is as in case a, but with

- number of households served per unit: 10,
- sewer between shared UASB and trunk sewer: max. length 200 m, min. slope 1/500, pipe diameter 15 cm.

The cost estimate is recorded in *Table 6.1*.

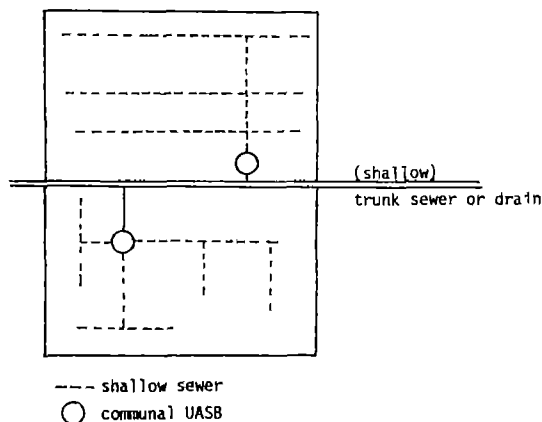

Figure 6.2 (a) Formalised layout of the studied case with township-level decentralisation applying UASBs.

6.2.3 Centralised treatment, sewage conveyed in drains + sewer (Case d)

A fourth approach that aims at lowering the overall costs of the sewage collection, conveyance and treatment scheme is to acknowledge the fact that the highest costs reside in the collection part (sewerage laterals). Therefore, instead of laying expensive sewerage in the often densely populated urban areas, it can be envisaged to use open or covered surface drains to collect (beside the storm water) sullage as well as part of the black waste water, in the form of the overflow of septic tanks and leaching cesspools with failing percolation facilities. This mixture is certainly unwanted from a public health point of view, but it can be argued that this situation has already existed for long periods in numerous high-density settlements that are not served by closed sewers, without being clearly correlated to endemic diseases. The achieved overall BOD removal within the system is limited to 20-30%.

The water collected in the drains flows over into a regular sewer at the edge of the high-density settlement. During rainfall, the drains discharge rain water into the sewer as well, but the overflow structure at the sewer's inlet is constructed in such a way that only a specified maximum flow is allowed into the sewer. Excess water, which is thus mixed with sewage, is drained in gutters along the main streets.

This approach has not yet been implemented often, it is being tried out in two sites in Indonesia, *i.a.* in the **Setiabudi** area in Jakarta. The eventual treatment takes place centrally, the treatment technology chosen should preferably be capable of handling the full sewage mixture, which is considerably diluted. In this sense anaerobic treatment is less appropriate.

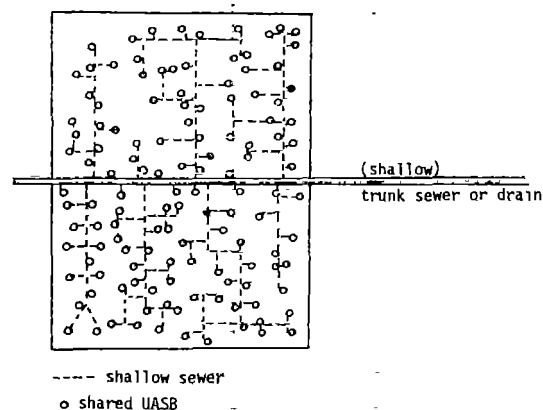

(b) Formalised layout of the studied case with decentralisation applying shared UASBs (one unit per 10 households)

Costs have been tentatively estimated for a "formalised" layout, on the same basis as in the cases b and c of the previous Section. They are reported in *Table 6.1*. Design basis is:

- existing in-township drainage and on-site waste disposal infrastructure is upgraded, cost: 10% of cost of new infrastructure using open lined drains and lined pits,
- flow accepted by sewer: dry-weather flow (DWF) + storm water (4 x DWF);
- trunk sewer is of conventional design, because sewage carries settleable matter and grit. slope 2.6 to 1.15‰, pipe diameter 0.3 to 0.7 m.

It appears that the higher flow rates necessitate much larger pipe diameters than in case c, but the corresponding velocities are sufficiently elevated not to need the same steep slopes.

Cases b and c involve total construction costs of app. 7.5 and 7.8 US\$/cap, against 6.3-9.2 for case d. Given the tentative nature of this calculation, the differences are not really significant. The important point however is that within an environmental protection strategy cases c and certainly b score markedly higher than case d, at competitive cost. From an operational point of view, case b has the crucial additional advantage of allowing professional control over a much smaller number of treatment facilities, which increases overall reliability.

6.2.4 Centralised treatment, sewage conveyed in drains (Case e)

A variant on the "Setiabudi" scheme is the collection of drainage and storm water, sullage and possible overflows of on-site sanitation facilities, in an open or covered drainage system in the city. The collected

water is then conveyed out of the urban area in an open, relatively wide channel with limited slope. The water is in dry weather conditions definitely to be regarded as waste water, and is led to a treatment facility. Since this transportation drain is comparatively cheap and easy to maintain, it is now feasible to bring the waste water sufficiently far away from the city where land price is low and ponds are economically attractive.

Two such schemes were designed and built in the period 1987-1989 in **Khon Kaen** and **Nakon Ratchasima**, Thailand. The schemes were started in 1989, but experience is still limited. The crucial concern pertains to the public health impact of a publicly accessible open drain; of course, the public is discouraged from making use of the drained water, but the question remains whether the local community, in particular the poor and rural people, will be able to recognise the risks involved. By extension, the question is in how far any positive experience can be extrapolated to other countries with a different culture.

The schemes, however, have considerable advantages with a clear overall economic benefit. (i) the waste water is collected and transported in relatively cheap and easy-to-construct drains that are also easily accessible and thus cheap in maintenance, (ii) as a result, the centralised treatment plant, of a land-intensive type (ponds) combining efficient and effective operation with low costs, can be located away from the city on cheap land, and (iii) the open drain functions as unintended primary treatment.

6.2.5 Anaerobic treatment in waste water re-use schemes

"Sewage farming" was one of the first methods adopted in Europe in the 19th century to dispose of raw sewage. High land costs in these countries quickly rendered the

Table 6.1 Construction cost estimates for waste water conveyance and local (pre-)treatment (excluded land costs) for three waste water conveyance schemes (cases b, c and d) as applied on a formalised urban layout. Costs as for Indonesian conditions (US\$/cap)

Scheme component	Case b	Case c	Case d
	Township UASB	Shared UASB	On-site + drain + sewer
Collection system			
- in unplanned area	4.7	4.9	0.4
- in planned area	4.4	4.7	0.4
Trunk sewer (3 km length)	3	3	5.9-8.8
Removal efficiency on BOD as can be achieved by the available local treatment	70-80%	60-70%	20-30%

Table 6.2 Recommended microbiological quality guidelines for sewage meant for irrigation purposes (WHO, 1989). Figures are meant as design goals, not maximum permissible values.

Re-use	Exposed group	Faecal coliforms (-/100 mL)	Intestinal nematodes (ova/L)
Crops eaten uncooked, sports fields, parks	Workers, consumers, public	≤ 1,000 ¹	≤ 1
Cereal, industrial fodder crops, pasture, trees	Workers	no standard required	≤ 1
Localized, no exposure to workers or public	None required	no standard required	no standard

¹ For public or hotel lawns with which public comes into direct contact. ≤ 200 faecal coliforms/100 mL.

method unfeasible however. In many arid countries on the other hand, both industrialised and non-industrialised, sewage farming became increasingly popular as an instrument of water conservation. In almost all these cases the sewage is treated prior to its re-use in an attempt to reduce the health risk to the public, the consumers and the agricultural workers. Re-use of treated effluent for irrigation and greenspace watering is practiced in Spain and other Mediterranean countries, North Africa (Tunis), Israel, Jordan (Amman), Saudi Arabia, Kuwait, Peru (Lima, Ica), Mexico (Mexico City), South Africa, Australia (Melbourne), the USA, and notably in India. In addition it has economic importance for pisciculture and aquaculture in India (Calcutta), several Eastern Asian countries and Western Germany (Munich). In these cases emphasis lies on nutrient re-use rather than on water conservation.

In this context pathogen removal is the most relevant yardstick for waste water treatment performance. Removal of BOD and suspended matter are of much less urgency; suspended solids should be low enough to allow easy transportation of the sewage and should not cause siltation of the irrigated soil (blocking of soil pores). Treatment may even be sub-optimal as the fertilizing value of the sewage (notably its P content) is reduced: during aerobic treatment some of the N content and a considerable portion (10-30%) of the P content are incorporated in the biological sludge (biomass)². Conventional sewage treatment thus reduces the intrinsic value of the re-used sewage, and adds the high cost of the treatment and sludge handling. Anaerobic high-rate treatment has here an advantage because it produces less excess sludge and leaves

nearly all nutrients in the effluent. Neither treatment is capable of complete removal of pathogens (see Table 5.4). There exists therefore often a tendency to apply ponds with sufficient retention time as treatment before re-use; they have, as discussed in Sections 5.4 and 5.5, the advantage of being in principle cheap in construction, easy in operation and reliable.

The risk associated with a particular pathogen depends on its number excreted by humans, its infective dose (depends *i.a.* on host immunity), its capacity to multiply after excretion, its latency (time between excretion and its becoming infective; pertains to helminths only), its persistence in the environment, and the possible transmission routes involved (may be via intermediate hosts).

Quality guidelines were formerly based on the wish to eliminate any potential risk to health, they were influenced by approaches of the water supply subsector in the sense that only bacterial indicators were considered and that sometimes very strict drinking water quality standards were applied. Recent epidemiologic evidence however, shows that possible diseases are caused notably by helminths, that are conventionally not monitored; therefore new guidelines need to be set up using a quite different concept. Based on this data and comparison with other standards, *e.g.* for bathing waters, recommendations have been condensed into two major parameters as described in Table 6.2.

These new guidelines are by consequence stricter with respect to helminths, but relax previous recommendations for bacterial contamination. The intestinal nematodes (a broad category) should serve as indicator organisms for all the large settleable pathogens, including amoebic cysts. No bacterial guideline was considered necessary in cases where farm workers are the only exposed population, since there is little or no evidence indicating a risk to such workers from bacte-

² At an irrigation rate of 2 m³/yr, which is commonly required in semi-arid regions, typical sewage concentrations of 15 mg N/L and 3 mg P/L correspond to annual nitrogen and phosphorus application rates of 300 and 60 kg/ha, resp. Such nutrient inputs can eliminate the need for commercial fertilizer (WHO, 1989).

ria. The recommendations would call for a helminth removal efficiency of 99.9%; however in regions where intestinal helminths are not endemic, a 90% efficiency would suffice.

As for pisci- and aquaculture, tentative recommendations include

- for pond water: average faecal coliforms $\leq 10^3$ /100 mL;
- for the waste water flowing to the pond average faecal coliforms $\leq 10^3$ - 10^4 /100 mL,
- for both, zero helminth ova

The above discussion is highly relevant to the question whether anaerobic treatment can have a specific place in re-use schemes. Under the old guidelines this question was to be answered negatively, unless the anaerobic treatment was only pre-treatment prior to comprehensive disinfection or impoundment. The new guidelines focussing on ova removal lead to the following conclusions:

(i) if the 1,000 faecal coliform/100 mL standard needs to be achieved, and

- land price is low (say below US\$ 3-5/m²), a series of ponds with long retention time (typically 25 d) is advised;

- land price is higher, a UASB followed by a smaller pond series is optimal;

(ii) if no bacterial standard applies, and

- land price is low, a series of ponds with retention time of 8 to 10 days is advisable to meet the helminth standard;

- land price is higher, a single UASB, or a UASB followed by a small polishing pond (retention time 1 d) is optimal; the difference depending on whether intestinal nematodes are endemic.

It is often proposed to achieve good bacteriologic quality by chemically disinfecting the raw or partially treated effluent. This practice is not recommended for general purposes, given the need for careful and cautious operation, the high dosages and hence high

recurrent costs, the doubts about the efficiency of the disinfection in the complex mixtures waste waters, and the concern about the generation of carcinogenic trihalomethanes.

Besides the public health related criteria few other guidelines restrict the re-use of (partially) treated waste water in irrigation. FAO (1985) has published a comprehensive guideline in which four problem categories – salinity, infiltration, toxicity and miscellaneous – are used for evaluation of conventional sources of irrigation water. (Partially) treated sewage falls in the category of water for which a slight to moderate degree of restriction is advised. This restriction is due to the relatively elevated concentrations of total dissolved salts (> 450 mg/L), chlorides (> 4 meq/L), boron (> 0.7 mg/L) and nitrate (> 5 mg NO₃/L). Only rarely would the sewage be characterized by concentrations rendering it unfit for irrigation. None of these criteria are actually positively affected by “normal” sewage treatment; biological aerobic treatment would even rather lead to an increase in NO₃ concentration as compared to raw sewage.

In general terms aerobic treatment would be less optimal than anaerobic treatment, as it does not perform significantly better in pathogens removal, and needs a higher cost. It is also important to realize that, in the set of anaerobic sewage treatment technologies, UASBs perform best, as they possess a remarkable capacity for removal of settleable matter and thus, to a reasonable degree, of helminth ova. The additional value of the UASB pre-treating the sewage for irrigation or aquaculture, is its function as “conditioner”: excess suspended and oxidizable matter which is not useful is partially removed, reducing development of septic conditions or other problems during transportation and the first hours after application.

Finally, excess sludge from an aerobic or anaerobic reactor has a high nutritional value as well and can be applied as fertilizer. The sludge, if not digested anaerobically for at least 25 days, may contain pathogens and hence need to be handled with care.

7 Summary and Conclusions

7.1 Background

1. The report reflects the findings of the feasibility study undertaken to assess the appropriateness of anaerobic treatment systems in sanitation programmes for urban and peri-urban residential areas in developing countries.

The study focusses on the treatment and disposal of domestic liquid waste flows: **toilet waste water** (black waste water) and **sullage** from kitchen and/or bath. Together they form the **grey waste water**. When also storm water from urban run-off is included (application of a combined sewer system) the sewage is called **combined sewage**.

2. Substantial information on performance and cost data of high-rate anaerobic systems (*i.e.* with hydraulic retention time typically below 10 h) applied at field conditions were obtained from DGIS funded research projects in Colombia, Indonesia and India. In these projects the Upflow Anaerobic Sludge Blanket reactor (UASB) was investigated. With some restrictions the validity of the presented conclusions may be generalized to other anaerobic technologies as far as they have a proven record of reliable performance under field conditions in developing countries. Other collected information pertains to different reactor types and anaerobic ponds.

All statements hereunder are based on the experience with several pilot and demonstration plants with a reactor volume of 50-1,200 m³, that have operated on domestic sewage under steady-state conditions for prolonged periods (at least three months, and up to a few years).

7.2 Determinants for sanitation programme planning

3. In sanitation programme planning the available sanitation technologies can be distinguished into two major categories: **on-site sanitation** at household level and **off-site sanitation** at city level. An **intermediate-scale sanitation** opens new perspectives and may be more cost-effective in less-industrialised countries; it aims at pre-treatment at on-site level for a number of households ("shared" treatment) or for a township ("communal" treatment) followed by trans-

portation through cheaper shallow sewers or open drainage networks to a central place outside the city to allow for final treatment and disposal. Anaerobic treatment facilities could play an important role in intermediate-scale sanitation.

A sanitation **programme** (or system) comprises all elements like waste water collection, treatment, conveyance, and sludge disposal. It must fit a **strategy** that meets broader objectives. Within the programme anaerobic **treatment** may be more or may be less feasible than any other competitive treatment. Feasibility must be understood in its technical, economical, financial and institutional sense. Conversely, the introduction of a new treatment technology may have an effect on the other components of the programme, for example on the **design criteria** for the waste water collection system. It may create new opportunities for sanitation programmes. Therefore, the feasibility of treatment technology cannot be properly assessed without investigating its effects on its context too.

4. This study cannot provide decisive information regarding the master choice for an on-site or off-site approach.

5. The study outlines the determinants for sanitation programme planning in urban and peri-urban residential areas of developing countries. These determinants define whether on-site, intermediate or off-site sanitation is most appropriate for a given situation. They are:

- (i) the availability of some kind of sewerage system,
- (ii) site-specific conditions with respect to urbanisation pattern, population densities, soil permeability and stability and the existing service levels for infrastructural facilities like water supply,
- (iii) environmental considerations with respect to ground water or surface water pollution and its public health impact,
- (iv) institutional requirements to allow proper matching of the responsibilities for operating, maintaining, financing and care-taking between government and community,
- (v) socio-cultural and socio-economic constraints and opportunities that define the potentials for community involvement in construction and operation and maintenance, and for cost recovery,
- (vi) economic and financial cost analysis.

7.3 The feasibility of anaerobic systems at on-site level

6. On-site sanitation can range from **individual systems** serving one household, to **shared facilities** serving up to 5-10 households or **public facilities** where several households share one sanitary facility. Commonly the liquid wastes from the toilet are disposed of on-site by soil percolation systems, whilst sullage is drained away over the surface in gutters.

At on-site level sanitation should provide solutions to disposal of toilet waste as well as sullage. Toilet wastes are characterized by low flow (up to 40 liter per capita per day), high strength (in terms of COD or BOD) and health risks because of their pathogen content. Sullage is larger in volume (up to 200 liter per capita per day) and has lower concentrations of COD or BOD. Its total BOD load (kg per day) is comparable to or even higher than that of toilet waste, its pathogen content is negligible.

7. Anaerobic systems prove to be technically suitable for treatment of (black) toilet waste water, separately or in combination with sullage (grey waste water). In the latter case the removal efficiencies of the UASB for COD, BOD or TSS are lower than in the first because of the higher proportion of soluble BOD in the influent and the stronger fluctuations in hydraulic loading rates. However, when efficiency is calculated over the total waste water output of the household, the efficiency of the reactor treating the grey waste water is somewhat higher than that of the reactor for the black waste water only. The pathogen content of reactor effluent is however still too high.

Common practice is to let the reactor's or tank's effluent percolate into the soil. In this case, the better BOD removal performance of anaerobic reactors over that of septic tanks is irrelevant. If the overall sanitation strategy is to protect shallow ground water as source for drinking water, tank effluent is allowed to drain away in gutters over the surface, eventually reaching a surface water; in this case the advantage of BOD reduction gains relevance. None of the on-site options yields a good removal efficiency on pathogens, with the important exception of the on-site UASB reactor treating black waste water which has shown to be capable to remove substantially (up to 90-99%) helminth ova.

8. The need for regular care-taking of anaerobic systems is comparable to that of septic tanks; it can in principle be provided by the community. Desludging and overall monitoring may be partly a governmental

responsibility. A difficulty in the management of such sanitation programme lies in the high number of facilities distributed over a wide area of which parts are sometimes hardly accessible to carts and trucks that would remove the sludge. In addition, success strongly depends on the commitment and discipline of the owners. Recent reports from many countries stress that in practice the tank is often disconnected from the percolation bed after failure (clogging) of the bed; the cost for a new bed encourages owners to short-circuit the tank's effluent to the public open drain. Anaerobic upflow systems produce a markedly better quality effluent (in terms of BOD) and tend to have lower sludge production rates than conventional septic tanks.

9. In a large number of representative case-studies (based on Indonesian *kampung*s) indicative cost calculations show that **single leaching pits** will be usually the cheapest alternative amongst the technically feasible options. It features a TACH of Rp 30,000-50,000 (US\$ 18-31) depending on conditions, with a monthly contribution from the owner of typically Rp 1,200 (US\$ 0.75). The double leaching pit is financially feasible if population density is below 200 cap/ha for unplanned and 400 cap/ha for planned areas. People usually prefer double pit systems because of easier (dry) desludging.

Shared facilities are only 10% cheaper in TACH than their individual issues, the gain in tank construction is partly compensated by the additional cost for connections. TACH reflects capital investment and operational and maintenance costs.

Public facilities are always cheapest, as they provide toilet and treatment in one building for a number of families. However, in many countries their effective use is constrained by local socio-cultural patterns and poor institutional guidance. With increasing wealth they are generally quickly abandoned for facilities providing more privacy.

10. For a population density between 200 and 600 cap/ha a larger **communal facility** may be financially affordable, providing a toilet in each dwelling but treating the waste of 20-110 households in a centralised UASB type reactor. The effluent cannot be percolated any longer into the soil and must be drained via a gutter or sewer. A high proportion of self-help (up to 57% of construction cost) can help to keep cost low. In areas with a sloping terrain the number of population served can be higher. This option would provide the important advantage of reducing the total number of reactors/tanks considerably and having them located near a road with good access, thus greatly facilitating desludging. In addition, a local institutional organisa-

tion can be formed in which the owners pay a modest sum to an appointed caretaker, who thus can be held accountable and can be effectively supervised by a local government authority

7.4 Feasibility of anaerobic systems at intermediate scale

11. In densely populated residential areas the collection of waste water in small-bore or shallow sewer systems or open drains, with subsequent local treatment, may become cost effective because (i) the collection of the raw waste water takes place in cheaper sewer systems that can be adequately maintained (de-clogged) by the local community (provided an institutional set-up is effectuated), (ii) the reactors' effluent can be conveyed in trunk sewers or drains of cheaper design because much less settleable solids are to be carried, and (iii) a reasonable degree of treatment (say 60-70% BOD removal) is achieved. Liquid waste flows are collected from townships with up to several thousands of households. Treatment at this **intermediate scale or township level** (also termed community-on-site treatment or COST) does not allow for many conventional off-site treatment technologies as costs and complexity are prohibitive. Anaerobic systems appear to allow scaling down to this intermediate scale in technical as well as in operational and economic terms. The effluents can be further centrally post-treated outside the city.

This is an example of the situation where a novel treatment technology might create new types of sanitation programmes. This opportunity warrants further research

Prerequisites for the success of intermediate scale sanitation are proper matching of institutional responsibilities for the collection and treatment systems between local community and government, and careful planning and management in order to reduce public health risks associated with sludge removal and the possible presence of sewage in open drains.

Also communal, and possibly shared on-site treatment tanks/reactors can play a useful role in cheaper sanitation programmes in which their (partially treated) effluents are collected in shallow or small-bore sewers or open drains, and conveyed outside the town for final treatment.

7.5 Technical feasibility of anaerobic systems at off-site level

12. The comparative analysis of conventional off-site treatment systems and high-rate anaerobic systems was done on the basis of (i) the removal efficiencies

for oxygen consuming substances (BOD, NOD), nutrients (N and P), total suspended solids (TSS) and pathogens, (ii) the treatment efficacy, reflecting process stability, reliability and sturdiness and (iii) sludge production rates.

13. The critical importance of an effective organisation of the sanitation and waste water management sub-sector, involving the political, managerial, societal, scientific and technical standards factors, was discussed. However, it was found that most of these considerations are generic for all treatment systems. The introduction of new high-rate anaerobic treatment would nevertheless require a particular effort from the side of scientific support (problem-solving), and training of engineers, technicians (operators), and contractors

14. Off-site anaerobic sewage treatment efficiency is lower than that of comparable aerobic treatment. Depending on the sewage characteristics, BOD (as BOD_{total}) removal of typically 65-80% can be achieved at an optimal hydraulic retention time of (average over 24 h) 6 h. COD removal is generally 10% lower. Kjeldahl-nitrogen removal is minimal, at 5-10%. Further reactor optimisation could possibly increase BOD removal efficiency to 75-80% as median value for certain sewage types (more concentrated sewage, more organic suspended matter).

Corresponding effluent quality is, based on the situation for the pilot plant in Cali, Colombia (typical $BOD_{in} = 200$ mg/L), 30-35 mg BOD/L as median value, but the 80-percentile value (value exceeded in 20% of all cases) lies at 45-50 mg BOD/L. With high-strength waste water (like in Kanpur, India) these values are expected to be 5-10% higher.

As anaerobic effluent is unlikely to meet the effluent requirements that are most likely to be enforced in developing countries that embark on comprehensive waste water management programmes ($BOD \leq 20$ or 30 mg/L, or occasionally 50 mg/L), anaerobic treatment is to be considered an effective pre-treatment, necessitating, possibly in a later phase of the financing schedule, an aerobic post-treatment.

15. Competitive conventional aerobic treatment, like activated sludge systems and trickling filters, yield higher median removal efficiencies (85-95% on BOD_{total}) and, definitely at low loading, substantial nitrification (30-95%). Competitive so-called low-cost treatment systems, like anaerobic and stabilization ponds, and ponds with floating aquatic macrophytes, perform comparably or better than high-rate anaerobic reactors, but require very long hydraulic retention times

(8-25 days, against 6 hours for the UASB) and thus land.

16. Anaerobic treatment performs better and at lower cost with increasing waste water strength; aerobic treatment is less sensitive to this factor, and will actually consume less aeration energy (a major cost component) with decreasing waste water strength.

17. High-rate anaerobic sewage treatment facilities are characterized by a relatively variable effluent quality as a consequence of their once-through, single-step operation. Long-retention ponds have usually a constant effluent quality if well operated. Conventional aerobic treatment systems consist of at least two steps and feature high internal recycling rates, leading also to more constant performance (though their effluent is more susceptible to variation than commonly thought). If post-treatment is provided to the anaerobic treatment, the variability of the effluent quality will be considerably reduced and could possibly match that of conventional systems.

18. The anaerobic process (on demonstration plant scale) appears to be relatively sturdy and reliable, in the sense that sudden changes in the influent can be well accommodated. An actual retention time of 4 h is a minimum that can be allowed for only a number of hours daily.

It should be noted that in most pilot plant studies the reactors were fed most of the time at a constant or only moderately varying hydraulic load. Potentially disturbing conditions (peak hydraulic loads) have therefore not yet been fully accounted for.

19. The anaerobic process is sensitive to low temperatures. Therefore, it has probably less perspective in regions with a predominantly temperate climate, with sewage temperature systematically below 20 °C. It is expected that a properly functioning reactor, with an active sludge, can accommodate during a few months sewage with regularly "colder" sewage, for example night-time sewage with a minimum temperature of 18 or possibly even 16 °C. The claim that anaerobic treatment of the (in fact dilute) sewage can be made effective at systematically low temperatures has not yet been substantiated at demonstration scale.

20. Rain water should therefore be kept out of the sewer system whenever possible, to avoid dilution, temperature reduction and hydraulic shock loads.

A consequence is that in situations with combined sewerage all storm water surges must be by-passed, creating considerable uncontrolled pollution discharges.

If separate sewerage is applied, this problem should not occur. Aerobic treatment usually can accept up to 4 times the dry weather flow, and performs therefore, on a year-average basis, better than anaerobic treatment when treating combined sewage.

21. It is advised to operate an anaerobic reactor in such a way that it does not frequently need to cease functioning and be emptied. This holds true for UASB reactors (empty reactor volume, underneath the gas-sludge-liquid separator), but is of particular concern in the case of anaerobic filters, of which the reactor volume is filled with packing material. Active anaerobic sludge needs not necessarily to be protected from oxygen (air), and can be stored in open air. Restarting the reactor with fresh sludge takes one to two months, not much longer than in the case of aerobic processes.

22. Anaerobic upflow reactors functioning on combined sewerage may after a few years suffer from accumulation of heavy grit and sand at the bottom of the reactor, if no special precautions are taken.

23. In general excess biomass production in anaerobic processes is half the amount produced in aerobic treatment processes. Because of the contribution of settleable material in the sewage (primary sludge) to the total sludge production of a plant, the net difference is smaller but still significant. The sludge produced by an anaerobic reactor is stabilized and easy to handle (5-8 times more concentrated/thickened, much easier to dewater) when compared with sludge from aerobic plants. If aerobic post-treatment is provided, this comparative advantage could become less important.

24. Post-treatment can consist of an activated sludge system (in more industrialised countries), an oxidation ditch, a trickling filter (possibly without secondary clarifier – more suitable for developing countries), or a pond system. The design of the post-treatment will strongly depend on the requirements for nitrification and public health criteria (pathogen removal). If full nitrification is mandatory, post-treatment will become a major part of the plant.

Ponds are suitable for post-treatment if land is relatively cheap (< US\$ 15/m²); a retention time of 1 day is reported to allow attaining low discharge standards. Otherwise the more high-rate processes need to be selected. Cost calculations pertaining to The Netherlands show that the oxidation ditch would be suitable only for small to medium plant sizes (10,000-50,000 cap). In the other cases activated sludge systems are economically more suitable.

25. On some counts upflow anaerobic treatment has an advantage over downflow and filter reactors. On no count it has an appreciable disadvantage.

26. If land cost is low (< US\$ 3-8/m²) pond systems are a technically and economically attractive alternative to any other type of sewage treatment as they can generally meet all discharge standards.

7.6 Potential use in resource recovery schemes

27. Re-use of (partially treated) sewage deserves more attention than it receives now. Especially the high potentials of anaerobic effluent are to be further explored. Anaerobic effluent from a UASB type reactor will carry zero to small amounts of helminth ova (much less than most other treatment systems with comparable retention time) and still contains relatively high levels of the nutrients N and P, given these factors, this particular effluent may be advantageous in crop production schemes (irrigation and aquaculture). Potentials for fish production exist, and integration of fish production and waste water treatment deserves further study.

Anaerobic treatment with UASB reactors has a technical and economic advantage over competitive treatment processes as “pre-treatment” before land application or other re-use, because at fairly low cost it reduces organic matter content to a reasonable degree, and removes settleable matter and the most important pathogens in this context (helminth ova). Integration of additional natural purification processes and recovery of resources may further contribute to the attraction of sanitation programmes incorporating anaerobic technology.

The above recommendations are equally relevant in the case of intermediate scale treatment, with anaerobic treatment at township level or with communal or even shared facilities provided effluent is collected and drained to the re-use location.

28. Biogas recovery and direct use for heating or other domestic purposes seems to be feasible only at large-scale off-site treatment plants where an institutional consumer of the biogas can be found. Small-scale utilization of biogas in an urban environment hurts on problems related to the biogas handling (piping, compressors, storage) and safety measures. Biogas from sludge and manure digesters can be more easily utilized in small villages where the value of energy is high, consumption low and the safety risks much smaller. Valuation of the biogas by electricity generation is economically feasible in larger waste water treatment plants but unlikely to become a decisive

argument in favour of anaerobic treatment in view of the costs involved for handling the biogas and its conversion into electricity.

7.7 Economic/financial analysis

29. For both on-site and off-site treatment options, construction and O & M (operation and maintenance) costs were determined, after which economic costs were calculated for all relevant alternatives.

In the case of on-site sanitation, Total Annual Cost per Household (TACH) for comprehensive sanitation programmes covering complete townships, including the treatment, was calculated and taken as the main yardstick to compare alternatives for the representative case-study.

In the case of off-site sanitation, only the treatment alternatives were considered, the cost of sewerage the area being too sensitive to local physical and economic conditions; costs were expressed as Net Present Values (NPV) or Total Annual Cost (TAC) and are mostly borrowed from other sources spanning numerous cases.

30. For the on-site case-study financing requirements were calculated, and compared against assumed but realistic income distributions, to assess the affordability of the different programmes.

31. Economic cost assessment under various conditions shows that, for treatment performance up to effluent quality of 20 mg BOD/L, anaerobic treatment (in a UASB reactor) completed with post-treatment, is often competitive with conventional alternatives. Pond systems however, are always cheapest if land price is low (typically below US\$ 3-8/m²). Small to medium-scale treatment plants (10,000-100,000 cap) may in many cases benefit from application of UASB, particularly if post-treatment consists of an oxidation ditch or a pond. For larger plants, in particular in the more industrialised countries, conventional treatment, like activated sludge, will tend to be cheaper.

32. A case-study calculation has shown that, for example in such intermediate scale schemes, it is technically and economically possible to introduce shared (by up to 5 households) and communal (10-110 households, if terrain slopes, more households can be connected) reactors.

Financially, the most attractive options are the simple individual leaching pit (with effluent percolation into the soil), and the communal UASB (with effluent drained away in sewer or open drain)

7.8 The landscape-matrix

33. Based on these conclusions a landscape- and selection matrix is presented in *Table 7.1*. The matrix sets **strategies** against **site conditions** that together determine categories (niches) of **sanitation programmes** and **treatment technologies**. In the matrix, the most feasible solution is indicated in bold type, with special reference to anaerobic treatment. "Most feasible" means here, with respect to those determinants that have been defined earlier (*Section 2.3*) and that can be applied as **criteria**: economic, financial, institutional (including opportunities for community involvement) and socio-cultural.

The determinants together with the opportunities created by the different sanitation technologies help to better identify the relevant strategies, site conditions, and the criteria to evaluate feasibility

34. The **sanitation strategies** are formulated in terms of

(i) environment (surface water) protection at different levels:

– medium quality standard for discharges into surface water (BOD 50 mg/L);

– sharp quality standard (BOD 30 or 20 mg/L);

– very sharp quality standard (as above, but with substantial nitrification to further reduce oxygen consumption); this is presently the case in most industrialised countries;

– advanced quality standards (ditto, but with complete control of eutrophication (N- and/or P-removal); this will probably become the situation in many industrialised countries in the near future);

(ii) public health protection: aiming at optimisation of pathogen (notably bacteria) removal from the immediate habitat (therefore preference for percolation of on-site treatment effluents into the soil), and environment in general (therefore off-site treatment systems that feature high pathogen removal like long-retention ponds);

(iii) ground water protection: aiming at safeguarding shallow well water for its use by the poor local community as drinking water (hence effluents from on-site sanitation facilities to be drained away over the surface or in sewers, or cartage of night-soil),

(iv) re-use potential: in irrigation and in aqua- and pisciculture, the former requiring less advanced pathogen removal,

(v) sludge fate.

The **site conditions** that appeared to strongly determine the feasibility of treatment technologies, were formulated as follows:

(i) at one extreme, the "easiest" site, characterized by an uncongested condition; whether it is planned or unplanned bears little relevance because it is assumed to coincide generally with richer areas in which sewerage exists or can be provided despite a high cost, or areas that may be less wealthy but in which drains or sewers would not represent a prohibitive cost. At the other extreme, the most "difficult" site to work in is typically congested and unplanned or partly unplanned; this generally would coincide with poorer urban quarters that are less well to do. Under such condition sewerage or adequate drainage becomes too expensive or technically unfeasible. In between a third situation is acknowledged which would possibly feature low-cost sewerage or other simple alternatives;

(ii) if sewerage is feasible, selection of off-site treatment technology will further depend on land price outside the city or town;

(iii) if sewerage is not feasible, further distinction can be made for a number of situations, depending on average household income level. In the case of the lower income range the selection may still sometimes depend on the (assumed) strength of a potential local institutional framework.

35. Concludingly, anaerobic sewage treatment has in developing countries with a tropical or sub-tropical climate in a number of situations a clear perspective.

In industrialised countries, or developing countries with a more temperate climate, application of anaerobic sewage treatment may in a few cases be valuable, but economic gains could be only marginal.

7.9 Needs for further research

36. Relevant further research and development subjects are.

– Studying in more detail and with realistic unit prices the overall cost of anaerobic treatment plants; to be done preferably for two or three representative cases (countries), and including sensitivity analysis and comparison with alternatives.

– Implementation at demonstration scale of a sanitation programme incorporating anaerobic sewage treatment at the levels of communal treatment (10-110 households) and of townships, including the, possibly country-specific, development of appropriate sewerage and drainage systems to collect and convey waste water; special attention to be given to the financial, institutional and socio-economic aspects.

– Development of multi-stage and hybrid (upflow and filter principle) anaerobic reactor types in order to increase removal performance, particularly at lower temperatures.

- Development, and demonstration of the feasibility, of post-treatment for anaerobic sewage reactors, notably ponds, cascade, oxidation ditch and trickling filter
- Research on the public health impact of sewage or partially treated sewage in open drains in settlements.
- Research and demonstration of techniques to collect effectively sludge from on-site treatment facilities; to be included are characterization of the sludge from different tank/treatment types, methods to dewater, methods to disinfect the sludge and turn it into a useful fertilizer, marketing of this fertilizer, setting up a workable institutional framework to manage the desludging activities with full cost-recovery, and methods to treat the produced supernatant before it can be discharged.

Table 7.1 Landscape and selection matrix for wet on-site and off-site low-cost sanitation programmes and treatment technologies in tropical developing countries with special reference to the position of anaerobic treatment. The treatment technologies and programmes that are probably most feasible in a given strategy with respect to the determinants (economic, financial, institutional, socio-cultural) are indicated.

Site condition	Planned or unplanned uncongested area (medium to high income) ¹		Unplanned congested area (low to medium income) ¹			
	Sewerage feasible		Low-cost sewerage/ drainage feasible		Sewerage not feasible	
	Land price near town				Household income/month	
	≤ US\$ 5	> US\$ 5			≤ US\$ 35	> US\$ 35
				Local instt. framework strong weak		
Estimated size of target population in the world (% of total population)	25	15-20	25	25		
Strategy						
A. Environmental protection						
I BOD ₅ = 50 mg/L	pond	UASB	communal ³ or township UASB (for preferably grey ww.)	on-site black ww percolated; and sillage properly drained away in existing drain and treated off-site		
II BOD ₅ ≤ 20 mg/L	series of ponds	UASB + post-treatment ²	communal or township UASB + off-site post-treatment	ditto		
III BOD ₅ ≤ 20 mg/L 75% nitrification	series of ponds	UASB + post-treatment ² or full aerobic treatment	communal or township UASB + off-site post-treatment	prohibitively expensive	unless	subsidized
IV BOD ₅ ≤ 20 mg/L 75% nitrification eutrophic control	as III but with appropriate tertiary treatment		prohibitively expensive	prohibitively expensive	unless	subsidized
B. Public health	series of ponds; or dilution in river		effluent of communal or township UASB conveyed in closed sewer + off-site post-treatment	(double) leaching pit, public ³ toilet	(double) leaching pit or sept. tank + trench, cartage	(double) leaching pit
C. Ground water protection	go to A	go to A	go to A	cartage; public toilet near township + sewer; shared ³ UASB with effluent conveyed via open drain.		
D. Re-use						
I in irrigation	ponds (HRT = 9d)	UASB	communal or township UASB (+ off-site pond)	only sludge can be re-used; toilet near drain		
II in aqua- and pisciculture	series of ponds (HRT = 25d)	UASB + series of ponds	communal or township UASB + off-site series of ponds	ditto		
X. Sludge fate	off-site dewatered, possibly after digestion, sludge sold as fertilizer or dumped		tank desludged and sludge locally or centrally dewatered; as fertilizer or dumped	pits emptied and tanks desludged by carts (private or govt. cy.); stabilized and disinfected, dewatered; sold as fertilizer or dumped; shared ³ tanks easier desludged		

1 Congested area means typical population density of > 500 cap/ha. without multi-storeyed buildings. Monthly income is here considered to be typically US\$ 35-70

2 Post-treatment may include pond, physical or aerobic treatment depending on land cost.

3 "Communal" means for 10-110 households, "Shared" means for 2-5 households, "Public" toilet facilities aim typically at 5-50 households, and do not provide for individual house connections

Appendix 1

Waste Water Treatment Technologies

A1.1 Septic tanks

A septic tank is a closed tank, in which the black or grey waste water from one or several houses (up to fifty households) is treated. The treatment process in fact is only pre-treatment, since it consists of sedimentation and to some extent anaerobic stabilization of the settled sludge. BOD removal is limited to 30%, TSS can be 70% at maximum. The liquid fraction leaves the septic tank still carrying the bulk of the BOD and the pathogens. The volume of a septic tank for one household is usually 1-3 m³. The liquid can be disposed of by a leaching pit or leaching trench (infiltration into the soil), or into some kind of sewer system. Infiltration into the soil is a good solution as long as the amount of waste water does not exceed the natural capacity of self-purification and dilution.

Dependent on the capacity, the tank must be desludged in a period of one to several years. The amount of produced sludge varies from 20 to 60 liters per user per year. When the tank is not regularly desludged, solids may wash out and clog the soil infiltration system. This is the reason that in practice many septic tanks discharge directly into the surface water or storm water drain, although the effluent is certainly not suitable for this purpose.

Although the system is simple as it is, great care should be taken when designing a septic tank. The tank is usually made of concrete, but also asbestos-cement can be used. The system is used all over the world but designs vary considerably: the tank can be divided into two or more compartments, and the volume per user is dependent on the ambient temperature.

Design details can be found in: Pickford (1980), ENSIC (1982); Laak (1986); and Van der Graaf *et al* (1988).

A1.2 Pit latrine

A pit latrine is basically a hole in the ground in which faeces, urine and optionally also sullage are disposed of. The volume is about one cubic meter or more. The liquid fraction of the waste percolates into the soil, and eventually reaches the ground water. Solids accumulate in the pit and are stabilized, resulting in a sludge formation of 20 to 60 liters per user per year. This means that every two or three years the pit must be desludged, by hand or by vacuum truck.

In the double-pit concept, two pits are alternatingly used, thus leaving the sludge in the full pit to become mature and free of pathogens.

Indian experience (Sinha and Ghosh, 1990) indicates that single leaching pits are less appealing than double pits, because most owners object to remove (manually) the still wet sludge. Double leaching pits are therefore recommendable in low cost options.

The liquid fraction infiltrating into the ground can cause pollution of the ground water, especially with pathogens and nitrate, when population density exceeds the natural capacity of self-purification and dilution.

Two examples of pit latrines are shown on page 102. (Figures taken from Kalbermatten (1982))

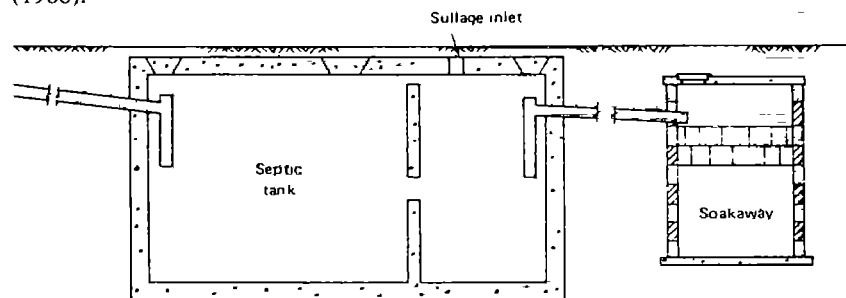

Figure A1.1 Septic tank (Kalbermatten, 1978).

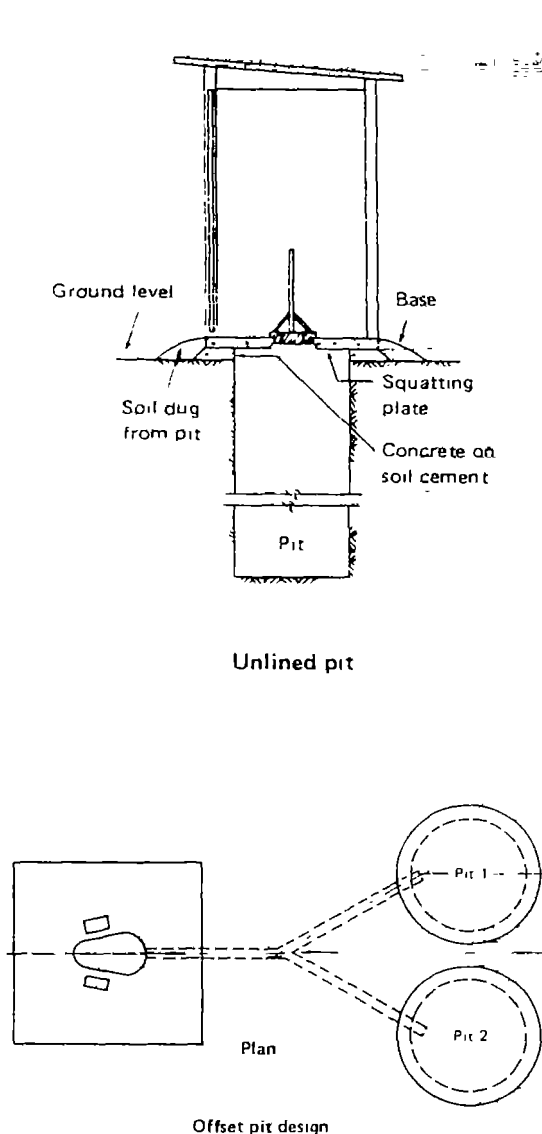

Figure A1.2 Pit latrines

A1.3 Waste Stabilization Ponds

A broad variation in process layout, design and performance exists. Most pond systems, however, are built up from the following elements:

1. Anaerobic lagoons. These are lagoons, very high loaded ($50\text{--}500\text{ g BOD}/(\text{m}^3\text{ day})$) so that the entire lagoon is anaerobic and the anaerobic stabilization is the main microbiological process. Further, sedimentation of suspended matter takes place. Because no aeration is necessary, the anaerobic pond can be as deep as is technically feasible, usually 2-4 m. This means that on a relatively small surface (compared to other pond types) the bulk (50-80%) of the BOD is removed. However, post-treatment of anaerobic effluent in aerobic lagoons is necessary.
2. Facultative lagoons, in which excessive algal growth and oxygen diffusion over the surface provides enough oxygen to maintain aerobic conditions in the upper layer of the pond. Near the bottom of the lagoon suspended matter settles and conditions are anaerobic. The loading is about 150 to 500 kg BOD/(ha day).
3. Maturation ponds: Low-loaded lagoons (50 to 150 kg BOD/(ha day)) in which the effluent of facultative lagoons is polished: Kjeldahl-nitrogen is oxidized and pathogens die off to a great extent due to the long retention time.

The above-mentioned characteristics apply to ponds under moderate or warm climates. The process is rather dependent on temperature. Pond systems are simple to operate, provide an effluent of good quality and do not require expensive technology or high energy inputs. However, large areas of land are necessary, and land price determines the economic attractiveness. The capacity of the system depends strongly on the climatic conditions, such as temperature and sunshine. Dependent on the load, the waste stabilization ponds must be desludged regularly. Well-maintained lagooning systems do not give nuisance caused by odors or mosquitos.

Further details can be found in Arthur (1983), *Water Science and Technology*, Vol 19, no 12, (1987), and Arceivala (1981).

A1.4 Aerated lagoons

An aerated lagoon is a lagoon provided with a mechanical aerator, and in this way it is the intermediate between the activated sludge process and a lagoon. Several types of aerated lagoons can be distinguished, dependent on loading rate and sludge recycling. Aerated lagoons are very practical solutions as they are compact (compared with algal ponds), and still very simple (compared with activated sludge plants).

However, the effluent quality is not so good. No nitrification takes place and BOD removal is below 80%. Only the very low-loaded types (with sludge recycling) usually meet the discharge standards.

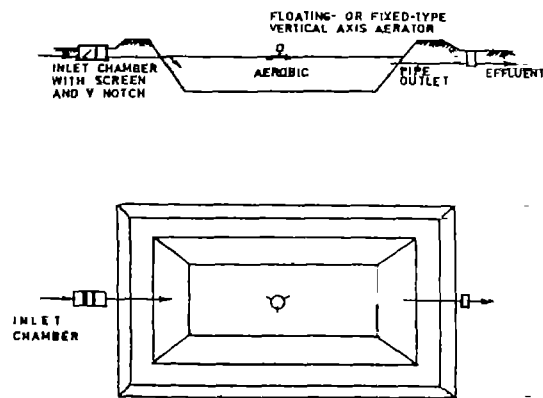

Figure A1.3 Aerated lagoon (Arcevala, 1981)

A1.5 The Activated sludge process

The activated sludge process has existed for nearly one hundred years and is very popular in industrial countries for its high efficiency and applicability on a large scale.

The process consists of a large aeration tank, in which the waste water is mixed with sludge consisting of active bacteria. The mixed liquid is aerated and the organic material is rapidly degraded (partly oxidized and partly integrated into new biomass). The sludge loading is 0.05 (extremely low) to 1 kg BOD/(kg MLSS.day).

In a separate tank the sludge is decanted and returned to the aeration tank. The continuous production of sludge (0.6 to 1.0 kg DM per kg of removed BOD) requires special installations for the treatment of excess sludge: thickening, digestion and dewatering. Primary sedimentation is also an important step in the treatment process, and is another source of sludge.

The basic process is shown in the figure below. Many process modifications have been developed during the years: e.g. two-stage processes like the German "A-B Verfahren"; plug-flow reactors with tapered aeration; Schreiber-process

Dependent on the loading and the process circumstances, the efficiency is about 90 to 95% removal of BOD. To improve effluent quality and to reduce operation costs, the modern activated sludge plant requires advanced process control. Nitrification/denitrification will avoid eutrophication of the receiving surface water and will save on costs for electricity. Phosphorus removal as an additional treatment step can be incorporated at various stages of the process.

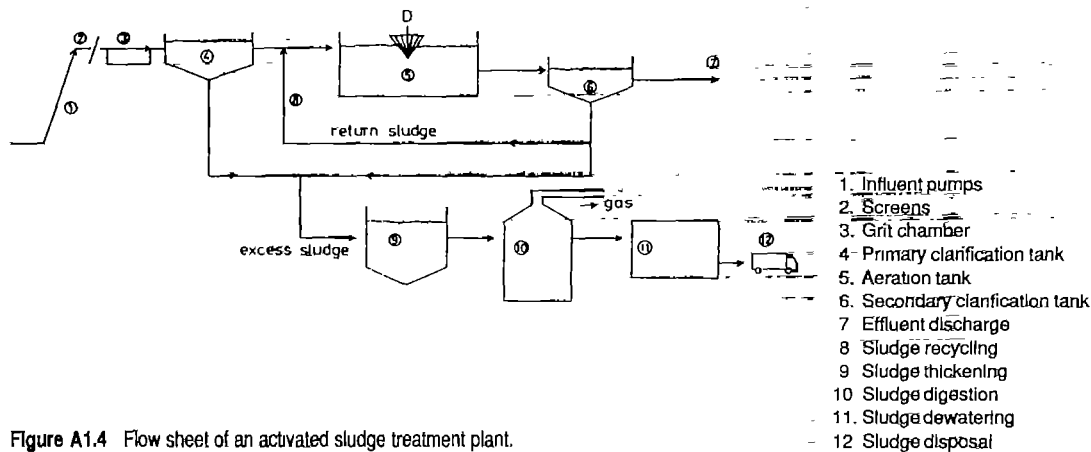

Figure A1.4 Flow sheet of an activated sludge treatment plant.

A1.6 Rotating Biological Contactors

Rotating biological contactors (RBCs) are discs, rotating with the lower part of the circle in a shallow tank through which the waste water flows (See Figure A1.5). The disc is covered with an aerobic biofilm, which is alternately exposed to the air, taking up oxygen, and to the waste water, absorbing organic matter. The process requires less energy than the activated sludge process (energy consumption is 500 kWh/1,000 kg BOD removed), but more land is necessary. A well-functioning RBC is reliable and efficient; it can be a complete treatment, or can be used as a post-treatment step. The effluent quality can be very high and is determined by the organic loading (in kg BOD per m² disc surface) and by the number of stages, usually 3 or 4. Sludge production is low, 0.6 kg DM/kg BOD removed, and the sludge volume index is well below 100 mL/g. Organic matter dissolved or suspended in the waste water is rapidly adsorbed by the biolayer and later degraded. Because of this, the system is capable of dealing with peak loading as well as periods of starvation. Because of the module-type of the RBC, it is a suitable system for upgrading existing treatment plants. As disadvantages are mentioned the sensitivity for temperature and toxicants, and the slow start-up. The technique is still young, and therefore not so widespread.

More information can be found in: Ministerie van Vlaamse Gemeenschap (1985); and Wijlhuizen and Nelissen (1983).

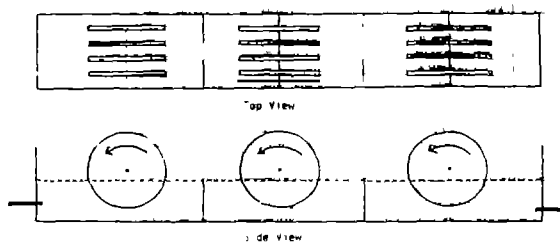

Figure A1.5 Schematic drawing of an RBC unit

A1.7 Oxidation ditches

Though it is strictly speaking a modification of the activated sludge process, the oxidation ditch is often seen as a rather specific waste water treatment technology.

The waste water is, without primary sedimentation, pumped into a closed loop (carousel) and mixed with the activated sludge. The contents of the aeration tank are mixed and aerated by rotors or cones. In this way the ditch is of a completely mixed type for waste water and sludge, but not for oxygen. The position and speed of the rotors facilitates a precise control of the oxygen concentration at the various places in the ditch (See Figure A1.6). This provides high process flexibility and possibilities for nitrification/denitrification within one tank. Oxidation ditches are low-loaded, sludge load approx 0.05 kg BOD/(kg MLSS.day). Consequently the sludge is aerobically stabilized in the aeration tank and the sludge production is small. Anaerobic sludge digestion is not feasible. Relatively speaking, construction costs are low compared to operation and maintenance costs.

Compared to activated sludge plants, no primary sedimentation is necessary and sludge handling is more simple. Therefore, the process requires little supervision and is very popular for small towns.

Effluent quality is excellent with regards to removal of BOD, TSS and ammonium.

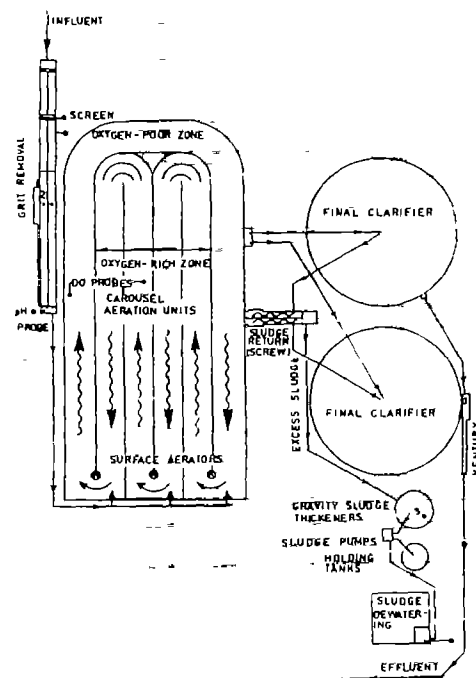

Figure A1.6 Layout of an oxidation ditch

A1.8 Trickling filters

A trickling filter is a bed filled with a coarse carrier material (lava stones, plastic filter media). Waste water is percolated through the filterbed downwards, and on the carrier a biological layer will develop, consisting of bacteria, protozoae and some inert material. Aeration takes place through a spontaneous (due to temperature differences) or forced air flow through the filter. Primary sedimentation is necessary to avoid blockage of the distribution device. Secondary sedimentation is also necessary, since excess sludge growth (parts of the biofilm) is washed out with the effluent. When ambient temperatures are sufficiently high, and the organic loading is not too large, nitrification can take place, and effluent quality is quite good.

An advantage is the simple operation, but a disadvantage is the limited flexibility of the process and the limitation on removal of nutrients (denitrification and dephosphatation)

A1.9 The use of macrophytes in waste water treatment

A considerable amount of research is spent on the use of macrophytes in waste water treatment schemes. Reddy and Debusk (1987) give an overview. Ponds with macrophytes can have various functions in the treatment process.

- Removal of nutrients and heavy metals by the plants;
- Input of oxygen into the system by means of transport of oxygen from the leaves to the roots, and from the roots diffusion into the water;
- Production of a potentially useful resource, namely biomass. This vegetal material can possibly be used as animal fodder, as a source of biogas, or to improve the fertility and structure of the soil (raw or composted).

A comprehensive monograph on the water hyacinth (*Eichornia crassipes*) is written by Gopal (1987), who considers it mainly as a tertiary treatment step. Other information can be obtained from the proceedings of the congress in Piricaba, Brazil (1987) about macrophytes in waste water treatment. (In: *Wat. Sci Techn.* Vol 19, no 10 (1987).) Still, some researchers claim good results treating raw domestic waste water in macrophyte ponds. (Orth, 1987, see Specker and Van Buuren, 1988) Publications are not clear on the fate of pathogens in the waste water.

Some drawbacks and unanswered questions still exist about macrophyte ponds.

- In many cases the use of harvested biomass was not technically or economically feasible
- In Brazil the ponds appeared to be the ideal environment for the growth of mosquitoes.

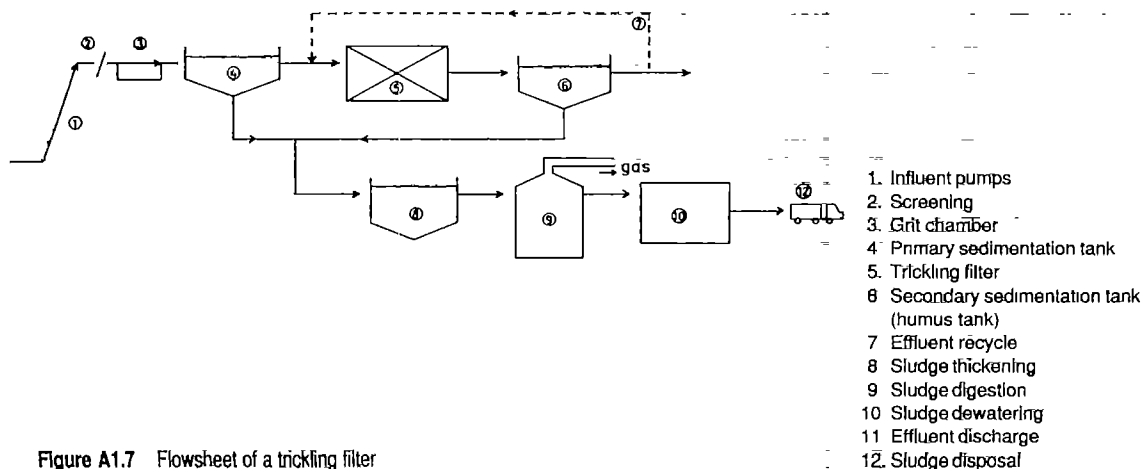

Figure A1.7 Flowsheet of a trickling filter

Appendix 2

Economic and Financial Assessment of Sanitation Projects: An Overview

A2.1 Introduction

This appendix is intended to provide information useful for engineers and others who are interested in assessing or justifying a sanitation project in financial or economic terms.

An understanding of the approach to economic and financial evaluation will enable a more detailed and comprehensive description of the costs and benefits of a project or projects. This, in turn, will enable a more convincing and realistic presentation of the recommended projects.

It is important to note that there is a clear distinction between the roles of economic and financial analysis. Economic analysis assesses the proposed project from the point of view of the economy or society as a whole. Financial analysis examines the proposed project from the point of view of one of the organisations/actors in the project, usually only the implementing organisation.

This section describes the approaches to economic and financial analysis relevant to anaerobic sanitation technologies. These approaches have not always been consistently applied and consequently, support for such projects has lacked a useful dimension.

In this section the aspects of economic and financial analysis which are relevant to the appraisal of anaerobic wastewater projects are discussed. The approaches outlined will also be useful to assist in comparative analysis when alternative systems of sanitation are considered.

A2.2 Economic analysis

A2.2.1 Elements of the analysis

The basic elements of economic analysis are costs and benefits. The value of a project to the community, and usually its economic priority are determined by comparing the benefits produced by the project to the costs incurred in its implementation.

1) Basic concepts

Some essential concepts are needed before the approach is outlined in detail. These are:

i) "With" and "Without" cases

A project is assessed in terms of the difference in costs and benefits to the community "with" the project,

versus the situation "without" the project. It should be noted that the "without" case is not the same as the present situation, or the "before" case. The present situation may get "better" or "worse" in the future of the "without" case

This is usually very important in the case of sanitation projects, as the future costs to the community "without" the project will be substantial, in health and clean up costs, and may not be reflected in current costs. These future savings are a legitimate benefit of a sanitation project. The usual problem is the difficulty in assessment of this benefit.

ii) No inflation

In assessment of economic costs and benefits, no adjustment is made for inflation after estimates are made for the current money value of benefits and costs of construction, operations and maintenance. Costs and benefits are given in "constant" money terms, using the year in which the costing is expressed as a base (*i.e.* constant 1988 US Dollars, constant 1989 Thai Baht)

It is important to be consistent in these costings, and this is often difficult in sanitation projects where records of past investment and costs may not exist.

iii) Opportunity costs

One of the most difficult concepts with respect to economic evaluation is that of the opportunity cost of a resource/input used for the project. This may be defined as the value of the next best use for the resource. It is very difficult to come to grips with the fact that something is a cost to the project even if it does not cost any money.

The most common and usually the most problematic inclusion of an opportunity cost is the cost of land. Government land used for a project has a cost, even if it is given free to the project. For this reason, free land used for extensive systems of wastewater treatment constitute a hidden subsidy and a cost to the community (the government could have rented the land).

iv) No interest payments

Capital investments are incorporated into the analysis at the time they occur. Interest payments on loans which are used to finance capital expenditure are transfer payments and do not constitute a cost to the

community as a whole. They are thus excluded from the analysis

v) *Assessment period*

The period over which the project is assessed is chosen to reflect the cyclical nature of many investments, and the difficulty of realistic prediction of costs and benefits too far into the future. Selection of an appropriate assessment period is particularly important for investments in sectors such as sanitation where technology is changing very quickly. In these circumstances, the investment period should not be too long. Such circumstances favour low cost alternatives which hold open future options

An example of an economic analysis is shown in *Table A2.1* which is located at the end of this appendix. The project described is an anaerobic sanitation project with a capital cost of 12.25 m, expended over fourteen years as shown. *Section A2.2.7* sets out this example in detail.

2) Definition of costs and benefits

1) *Costs*

The analysis attempts to identify all the inputs into a project and to cost them. This costing attempts to reflect the value of those inputs to the community. This is achieved by "shadow pricing" money costs of inputs using the techniques set out below. The outputs of the project are also examined and any which involve a cost to the community, for example pollution, are included on the cost side of the analysis. Where shadow pricing will result in little relative change in the components of costs and benefits, the accounting (money) prices are sometimes used. Further details will be set out in *Section A2.2.2* below

ii) *Benefits*

The analysis also attempts to identify the benefits of the outputs of a project. Again, these outputs are "shadow priced" in order to reflect their real benefit to the community, unless accounting prices will adequately reflect these benefits. Benefits counted to the project include all those which result from the project, both directly and indirectly. Further details will be set out in *Section A2.2.3* below

Thus a sanitation project has direct benefits to the community measured in money terms by the willingness of people to pay for the service. However, additional benefits in reduced pollution may accrue to people who live downstream of the project. These people will not usually pay for this benefit, which is nevertheless a benefit to the community as a whole.

Such benefits should be counted as a benefit of the project.

A2.2.2 Costs

It is now necessary to look at costs in more detail. Costs may be divided in many ways, but for the present analysis they will be divided initially into capital costs, operation and maintenance (O&M) costs, and other costs.

1) *Capital costs*

Capital is usually defined as the produced means of production. Costs incurred in order to provide the means of production are capital costs. These costs are usually for equipment or facilities such as sewerage treatment plants, septic tanks, sewer pipes, computers, pump trucks, etc. which are the means of production for a sanitation service. Note that capital costs include all costs that are required to bring the capital into production. Thus, they include land costs (even if the land is "free" it has an opportunity cost), and other "set up" costs, such as management time and training.

Before undertaking an analysis of a proposed sanitation system, several aspects of capital costs should be confirmed. These are.

1) *Plans and standards used*

It is important that capital expenditures should be undertaken to a strategic plan. This plan should set out over time the appropriate level of technology required to reach the target groups identified by the plan.

Standards adopted should also have been assessed to ensure they are appropriate for the size and distribution of the population served, and the level and distribution of income of that population.

The implications of inappropriate choice of technology or standards are serious, as these costs must ultimately be borne by the users directly or by the government. If a high cost choice requires higher tariffs, lower demand will often result in wasted resources and an inequitable distribution of services.

In the case of sanitation technologies, this implies that cheaper anaerobic technologies may be the preferred option when affordability constrains demand.

ii) *Construction/procurement supervision and schedule*

Once a plan is agreed, the construction and/or procurement of capital equipment must be undertaken. The design and supervision of these activities is also a capital cost. More importantly, the quality and availability of skilled people to undertake these activities must be assessed. Delays in, and lack of skills for, these activities will lead to cost overruns and ad-

versely affect the viability of the project.

Where such resource constraints are a potential problem, technologies that require less skills to design are to be favoured in order to minimise the risk of problems in this regard. Some anaerobic technologies have this advantage.

iii) *Treatment of capital costs*

Capital costs are included in the cashflow when they are incurred. In economic analysis, no adjustment is made for inflation and current estimates are used. Shadow pricing is used on these costs.

2) Operations and maintenance costs

i) *Documentation*

O&M costs are much easier to identify in concept than they are in reality. The total expenditures on the operation and maintenance of plant, equipment and buildings, and staff wages are relatively easy to identify in most finance systems.

The problems come when an attempt is made to separate out:

- any major upgrading on a capital item which should be counted as capital expenditures,
- planning work, for supervisors and designers, which should also be counted as capital expenditures, and
- O&M expenditures on one piece of capital equipment from those on other items. The design of financial systems should enable them to distinguish such expenditures.

ii) *Treatment of O&M costs*

O&M costs are included in the cashflow when they are incurred. In economic analysis, no adjustment is made for inflation and current estimates are used. Shadow pricing is used on these costs.

3) Other costs

i) *Types of other costs*

The other major type of cost considered in economic analysis is the "externality." External costs are usually costs of project outputs which are not costed in the project expenditure. Such costs are often related to pollution or disruption

This issue is, of course, particularly important for sanitation projects. If a particular type of treatment has a high probability of failing on a regular basis and causing pollution, this is a cost to the community. The cost of periodic clean up should be attributed to the project. Another example of such costs can be seen in the type of sanitation scheme which requires extensive excavation through city streets. The large scale

traffic disruption which results is a real cost to the community, but is often not costed to the project

ii) *Treatment of other costs*

Externalities are included in the cashflow when they are incurred if it is possible to estimate this, for example in the case of traffic disruption during construction. Where this is not possible then an annualised amount covering estimated costs should be included. In economic analysis, no adjustment is made for inflation and current estimates are used.

Shadow pricing is used on these costs.

A2.2.3 Benefits

1) Revenues

Revenues are an indicator of the value people place on the outputs of a project. The revenues derived from a project are of two types:

- once off sales income, for example in a property development project where property is sold, or connection fees in reticulated services,
- revenues derived from the use of the service, which usually amounts to the fee or tariff charged multiplied by the number of users

In both cases revenues are determined by demand, ie the number of sales, or users of the service. Demand is, in turn, determined by the price charged. The two major issues involved in a discussion of revenues are thus demand and tariff levels.

1) *Demand/Affordability*

Whether or not someone buys a product depends in the first instance, on his or her income. Such considerations as reliability and design are also important, but income determines whether or not it is possible to buy the product.

In general, the lower the price of a product, the more people will buy it. This elementary fact is often ignored by those who design systems to the requirements of established standards. The cost of these standards in relation to the income of the users is often ignored. (Note this is not always the case. For example, if the purchase of a lower cost sanitation technology shows the buyer to be poor, this may not be accepted by people who will feel ashamed at having to settle for something perceived as second best. See "willingness to pay" below.)

Such considerations are not important if there is a cross-subsidy from government to the service authority, but fiscal restraint is now often required on the part of central governments, and there is a push for more

efficient use of resources. The use of general subsidies is thus decreasing, and the concept of "user pays" is being implemented. From an equity viewpoint, the concept of "user pays" has much to recommend it, provided a range of service choices is available/feasible. Where such choices are not possible, effective institutions to implement cross-subsidy schemes are required to achieve an equitable solution.

If the user is going to pay, it is thus important to know what he or she can afford. Thus, surveys of household income and expenditure are an important tool in determining demand. Producing a scheme that is affordable to the target group is a major achievement, but is not sufficient. There must also be a "willingness to pay" on the part of potential users. In other words, the target group must be willing to spend money on the sanitation system offered, thereby not spending that income on, say, children's education. Again, attitudinal surveys can assist here.

In this respect, community participation in decision making is important, as representatives of the community often have a better grasp of the trade offs that are possible, and the likely levels of demand under different pricing (tariff) policies, than system designers.

ii) *Tariffs*

Determining appropriate tariff levels is a trial and error process. In this process various elements must be balanced. These are such elements as affordability, cost recovery policy, and appropriate level of technology. Once again, community participation should be introduced where possible to assist in this process. This issue will be examined in more detail in *Section A2.3.3*.

iii) *Treatment of revenues*

Revenues are included in the cashflow when they are earned. In economic analysis, no adjustment is made for inflation and current estimates are used. Shadow pricing is generally used on revenues.

2) **Other benefits**

i) *Types of other benefits*

The other major type of benefit considered in economic analysis is, as with costs, the "externality". External benefits are usually benefits of project outputs from which the project derives no revenue. Such benefits are often related to health or amenity. This issue is important for sanitation projects.

If a particular type of treatment has a high probability of producing substantial health benefits, this is a benefit to the community. The problem is quantifying these benefits.

Multiplier effects may also provide other benefits. These effects measure the stimulus or flow on effects of a project. For example, an investment of \$100 in a treatment plant is made. This \$100 is spent by the building contractor. He or she will spend some of the profit on a Mercedes and some on a bigger house; some of the costs will be for workers' wages, some for materials, and some for imported equipment. The payments for the Mercedes and the imported equipment leave the economy, in economic terminology they are "leakages", but the remainder of the spending by the contractor will be respent in another round of spending by those who receive the money. This process continues over several rounds of spending, decreased each time by the leakages (mainly imports and saving). The result of \$100 in investment may thus be an additional \$20 increase in the National Product. We say that the multiplier is 1.2.

If multiplier effects are significantly different for different technologies, then they may be important in economic appraisal. This may be the case, for example, when comparing two technologies, one of which has a high import content, the other of mostly local manufacture.

Note that external benefits counted in "other benefits" must not be part of what the users pay for, which is counted above. If this is the case, only the benefits which accrue to those outside the service area may be counted as additional benefit. It should be further noted that benefits counted to the project must satisfy the "with/without" test. This means that additional benefits counted in the "with project" case must be in addition to those which the community would have received anyway, ie in the "without" case. Thus an investment of \$100 in a market may have a multiplier (flow on or linkage) effect through the construction industry of 1.1 times the original investment. However, any investment which requires construction will have the same multiplier effect and thus the benefit is not "additional" to the community.

In general, multiplier effects should be treated with caution and only used where the case for additional benefit is strong.

ii) *Treatment of other benefits*

Other benefits are included in the cashflow when they are incurred, if it is possible to estimate this. In economic analysis, no adjustment is made for inflation and current estimates are used.

Shadow pricing is used on these benefits.

A2.2.4 Shadow pricing

In order to obtain an overview of this subject, it is necessary to review some of the key concepts involved.

These are the objectives of shadow pricing and the treatment of traded and nontraded goods

1) Objective of shadow pricing

The objective of Shadow Pricing is to establish the real value (to the community) of resources used and benefits realized by a project. In order to do this, shadow prices are formulated to exclude anything included in the money (or accounting) price of resources or benefits that represents:

- a transfer payment, *i.e.* a payment which is not for a resource transfer, for example, sales tax, a subsidy or interest on loans
- a "distortion" of the market, where governments deliberately interfere in specific prices, usually by fixing the price of a good directly, by giving tariff protection to a good, or by fixing the exchange rate. In economic terms the Shadow Pricing used in this analysis results in an Efficiency Price.

2) Traded versus nontraded goods

A good is "traded" if it is available as an import to the country. Distortions of the market to do with exchange rates and price fixing can, approximately, be eliminated by taking the border price, *i.e.* the c.i.f. price of the import, as the efficiency price. The efficiency price of nontraded goods, such as water and sanitation services, are also estimated.

A detailed example of the derivation of efficiency prices for nontraded goods is beyond the scope of the present document. It is sufficient to say that these factors are determined by assessing the taxes and distortions in the domestic economy, and then converting this assessment into a conversion factor which is applied to the accounting price. When conversion factors are estimated for both traded and nontraded goods the efficiency prices are given by the formula:

$$\text{Efficiency Price} = \text{Conversion Factor} \times \text{Accounting Price}$$

Various types and levels of conversion factors are available for use in a variety of situations. These factors can be specific to particular inputs and outputs, particular sectors, or general as with the Standard Conversion Factor (SCF). The SCF is often used as a rough approximation because it can be easily calculated.

3) Application of shadow pricing

Other factors can be applied to the determination of shadow prices in addition to the efficiency price outlined above. Adjustments for social priorities, for example benefits to low income groups can be made.

Benefits derived from the economic concept of consumer surplus can, with great caution be added to the analysis. These are, however, beyond the scope of the present discussion.

A2.2.5 Assessment

1) Cost Benefit Analysis and Cost Effectiveness Analysis

The assessment of a project requires some basis of comparison either with alternative projects. This is provided by the techniques of Cost Benefit Analysis (CBA) and Cost Effectiveness Analysis (CEA). The economic assessment of a project using CBA requires the determination of costs and benefits to the community over time. These costs and benefits are set out over time in a cashflow format. This format allows the use of CBA techniques and the "return" on the project can be calculated.

Where benefits are uncertain or where certain levels of outputs must be attained, CEA can be employed. The effectiveness of a project can be measured by comparing the cost of various projects which will achieve a given set of quantifiable outputs - not necessarily benefits. CEA establishes the least cost method of achieving a given project outcome.

2) CBA techniques

Two techniques will be discussed. These are the Benefit Cost Ratio (BCR) and the Internal Economic Rate of Return (IERR). These techniques both require the use of a cashflow format, and discounting.

Discounting is the economic technique used to reflect the time value of money, that is, the fact that one dollar today is more valuable to a person now than one dollar in a week's time. The choice of appropriate discount rate(s) is a political decision, but if none is suggested the rate applying to current long term government bonds is a first approximation. The discount rate is applied to the streams of costs and benefits, or to net benefits, to determine their present value.

The discounted value of net benefits (benefits-costs) is referred to as the Net Present Value (NPV). This measure can be used as an assessment technique, the project being viable if the NPV is positive at the chosen discount rate. The BCR is another way of presenting this result (see below).

In general, a high discount rate may erode the relative benefits of technologies, such as some anaerobic technologies, where there is a low O&M cost over time. This is because, at the higher rate, future costs have a lower present value.

i) *Benefit Cost Ratio*

The BCR is the ratio of the Present Value of the benefits of a project to the Present Value of the costs. Both Present Value calculations use the chosen discount rate to express future benefits and costs in terms of their value in the base year. If the BCR is greater than one the project should be undertaken.

ii) *Internal economic rate of return*

This is the discount rate that sets the BCR to one. The higher the present value of the benefits, the higher this rate will be. Governments may have established standards for rates of return. If none exist then a first approximation will be a minimum rate of that return applying to long term government bonds.

3) *Sensitivity*

The CBA and CEA techniques set out above are useful, but it must be remembered that this analysis takes place in an uncertain world. At the outset, our assumptions of discount rate may be inaccurate. Thus it is useful to examine the effects of variations in this rate. This will usually not have a great effect on the ranking of projects, but may make considerable differences in the content of an investment programme if fixed BCR criteria are to be applied.

Estimation of costs and benefits, and the elements which make up these items may be uncertain. This uncertainty should be reflected by testing likely variations of these elements. Such tests are called sensitivity tests and are usually carried out by varying the assumed level of an item by a reasonable percentage and assessing the outcome on the BCR and IERR. Where such variations cause a project to fail established criteria, they have identified an area of risk for the project. The question of what measures should be taken to reduce that risk then arises.

4) *CEA techniques*

CEA techniques use cashflows to set out costs, and then apply Cost Effectiveness Ratios (CERs) in assessment. CERs measure the Present Value of Costs incurred to achieve given levels of outputs. These levels usually express minimum standards of technical performance and of service. The lowest cost project which achieves these minimum levels should be the one chosen for implementation.

Difficulties occur with this approach when widely differing outputs are derived from projects. The need for trade offs among outputs raises the very difficult issue of weighting of these outputs. Sensitivity analysis should be carried out to determine the sensitivity of the ratios to changes in costs and outputs.

PRIORITIZATION

Extreme care must be used in ranking projects using the outcome of the above assessments (see World Bank Staff Working Paper No. 239, "Social Cost-Benefit Analysis," Part I, Appendix D). For mutually exclusive projects, where sufficient funds are available for any of the projects, the BCR can be used to prioritize. For prioritization across sectors, or across projects which are not mutually exclusive, other techniques, involving explicit or implicit weighting of criteria are used. These techniques are beyond the scope of this discussion.

A2.2.6 *Monitoring*

Monitoring of "Other" economic benefits and costs constitutes the most significant aspect in this stage of economic analysis. Most monitoring of actual expenditure and revenue, the basis of most of the economic analysis, will be carried out using the financial analysis. The external costs and benefits in particular may have a significant effect on the outcome of a project from the community's viewpoint.

Thus, these aspects of a project should be monitored, and, after an appropriate time, the performance of the project should be evaluated against the projected performance.

A2.2.7 *Example*

As seen from *Table A2.1* at the end of this appendix, the two major divisions of an economic analysis cashflow are Costs and Benefits. These are set out over the assessment period of 20 years. Our example shows capital costs lines 1 and 2. These lines represent the money costs and their shadow-priced equivalents respectively.

Lines 3 and 4 show O&M costs and their shadow prices. "Other costs" is shown in line 5 and refers to the costs of traffic disruption during construction. Shadow pricing has been incorporated in these costs.

Table A2.1 shows shadow priced revenues on line 11. These are derived from the projection of demand on line 7 and the tariff rates shown on line 9. Line 12 shows the other benefits which are derived from this project - savings in health costs. These have also been shadow priced. The BCR (line 15) is the ratio of the Present Value of line 13, Total Benefits, to the Present Value of line 6, Total Costs. The IERR (line 16) is calculated on Net Benefits (line 14).

A2.3 Financial analysis

A2.3.1 Elements of the analysis

The basic elements of financial analysis are expenditures and revenues. The financial analysis of a project can only be determined in relation to a specific group, usually the implementing organisation. This is done by comparing the project revenues accruing to a particular group, to the expenditures incurred by them. The analysis is often carried out in two stages; initially comparing the expenditures and revenues (profitability analysis), and then considering the financial options available for project financing. Related issues of liquidity and determination of tariffs/pricing are also important. The final financial analysis is carried out when the financing package is known/selected. An example of financial analysis carried out for the same project as described in *Section A2.2* is shown in *Table A2.2* at the end of this Appendix. The example is explained in *Section A2.3.7* below.

1) Basic concepts

Some essential concepts are needed before the approach is outlined in detail. These are:

i) "With" and "Without" cases

As with economic analysis, a project is assessed in terms of the difference in expenditure and revenue "with" the project, versus the situation "without" the project.

ii) Inflation is incorporated

In financial assessment, inflation is applied to both revenues and expenditures. In other words, we estimate the actual money paid and received by the project over time. Usually, this must be limited to applying an estimate of the inflation rate to expenditures and revenues, especially after the first few years. It should be noted that differing inflation rates may apply to different components.

Thus, if inflation is expected to be 10% per annum for maintenance expenditures, and that their current level, costing 100, will be maintained for two years, then the cost of maintenance will be 110 next year and 121 the year after that. The choice of waste water system may be influenced by the level of inflation. Where this is high, systems that can be constructed quickly or which contain high proportions of local input will be preferred. Similarly, systems which expose the user to high and uncertain levels of O&M expenditure are risky in an inflationary environment.

iii) Financial arrangements are central

Capital investments are incorporated into the prof-

itability analysis at the time they occur. From projected revenues, the financing requirements can be determined. Interest and principal payments on loans which are used to finance capital expenditure or working capital are incorporated in the financial analysis. The choice of system may be determined by the level of financing available for a particular systems. This is dangerous because inappropriate systems which have high levels of financing and/or subsidy for capital expenditures, but heavy O&M requirements, may be chosen over systems which are sustainable in the long term.

iv) Assessment period

The period over which the project is assessed is chosen to reflect the cyclical nature of many investments, and the financing structure. The assessment period for the financial analysis may not be the same as the period chosen for the economic analysis. It is often taken as the period of loan repayment after the last major capital expenditure.

2) Definition of expenditures and revenues

i) Expenditures

The analysis attempts to estimate all the money inputs to a project. Further details will be set out in *Section A2.3.2* below.

ii) Revenues

The analysis also attempts to estimate the money income of the project. Further details will be set out in *Section A2.3.3* below.

A2.3.2 Expenditures

It is now necessary to look at expenditures in more detail. As in the economic analysis, they will be divided initially into capital costs and operation and maintenance (O&M) costs.

1) Capital costs

Capital costs were explained in *Section A2.2.2* above. Once-off training programmes and activities related to the design and installation of capital equipment are also capital costs. In reality, however, capital is often not paid for in full by the implementation authority when it is purchased. It is either financed over the life of the item, or central government grants pay substantial amounts of the expenditure.

Before undertaking an analysis of a proposed sanitation system, several aspects of financial analysis relating to capital costs should be confirmed. These are:

i) *Loan terms*

The terms of loans, their length, grace period if any, interest rates must be established. The amount of an expense covered by the loan must also be established as alternative sources of external finance or reserves will be necessary to make up the difference. Note it is possible to obtain loans from commercial sources for working capital, where greatly increased O&M expenditure is required in the event of an expansion of an existing system. Where reserves will not cover the difference between finance and expenditures, such a course should be considered.

ii) *Subsidy (grant versus soft loan)*

While soft loans are in effect subsidies, there is in practice no difference in treatment from ordinary loans discussed above. The documentation and timing requirements for subsidies may be important in determining the cashflow of a project, however.

iii) *Cross subsidy*

Cross subsidy of one activity from another is difficult to justify in terms of equitable sharing of the costs of development according to the amount of resources consumed. If however, such a course is undertaken, careful recording of the extent of subsidy should occur in order to prevent "creeping" increases in subsidies.

iv) *Debt service policy/capacity to finance*

The level of debt to (net) cashflow, and to assets should be determined and checks placed to ensure that such ratios are not exceeded. These policies will vary with such things as the level of community participation, past revenue collection performance etc, and may influence the choice of system. Where a sanitation system, for example, has a high level of community participation and the community has shown itself to be capable of servicing debt, then a higher level of loan funding may be appropriate.

v) *Treatment of financing costs*

Financing costs (capital and interest payments) are included in the cashflow when they are incurred. They are not, of course, adjusted for inflation as the money payment does not change over the repayment period unless special factors apply. Where such variations on traditional principal/ interest repayment occur, the repayment schedule is usually just incorporated into the cashflow after calculation.

2) Operations and maintenance expenditure

1) *Administration costs*

These costs are often ignored. This is not serious

where they comprise a small amount of total costs, but where this is not the case, they should be accounted or they will constitute a hidden subsidy. Certain sanitation technologies have high administration costs over the life of the project. These should be included in the analysis of the project.

ii) *Training/education*

These costs are often ignored and should be treated as above.

iii) *Subsidy*

The same issues as discussed for capital subsidies in 1) (ii) above apply to O&M subsidies.

iv) *Treatment of O&M expenditures*

O&M costs are included in the cashflow when they are incurred. Adjustment is made for inflation of each component where practical. There anaerobic processes have more predictable construction costs and/or depend less on imports, they are less "risky" with respect to inflation. This may be an important factor in the choice of a system.

A2.3.3 Revenues

1) Revenues

Section A2.2.3 on economic assessment discussed the two major issues involved in determination of revenues -demand and tariff levels. In financial analysis several other, related, issues become important. These are:

i) *Cross subsidy and Cost recovery policy*

Cross subsidy in rates charged for services has two implications. The first is that the people eligible for the subsidy must be easily identifiable. The second is that the rate of review of the various rates must be regular, especially in times of inflation. Cost recovery policy is, of course, of prime importance in determining tariff levels required. This element relates to subsidies discussed under the expenditures above.

ii) *Required return on investment*

Again, tariff levels will be dependent on minimum levels of return set by the government.

iii) *Legal issues*

Primary importance must be given to confirming that the implementing agency does in fact have the required legal authority to set Tariffs, to cut service to non-payers, to enter properties to maintain and protect its assets etc. Revenue collection in sanitation projects is notoriously difficult.

The health consequences to the community from cutting off the service often make this option difficult. The need to link sanctions in this area to other services, for example water supply, is recognised.

iv) *Tariff review*

Given the legal power to carry out such periodic reviews, the authority must be willing to carry out the reviews in order to counter cost inflation. Sanitation tariffs may be of several different kinds. The most common are:

- a household charge either on a flat rate basis or based on property values,
- a base rate per household plus a service fee, for example for every pump out of a septic tank, and
- a surcharge on the water bill. A connection fee is also often charged for reticulated services.

The documentation and data collection requirements of various systems of setting tariffs referred to above, must be carefully assessed for ease of tariff review. They must also be considered from the point of view of the need to identify groups which will receive the benefit of cross-subsidy and to determine the level of that subsidy.

Each of these systems also has equity consequences for various groups of users. For example, a flat fee will usually discriminate against the poor, but it is probably the simplest method to administer.

v) *Collection mechanisms/effectiveness*

Given the legal power to collect revenues, the authority must be willing to collect revenues, penalise non-payers, and police its collection staff. Further, it must examine the effectiveness of its collection systems in terms of revenue collected per expenditure on collection. Alternative systems should be explored where performance is questionable.

Each of the tariff systems discussed in (iv) above have their own requirements for collection systems and the effectiveness of these systems depends on the sanitation technology chosen and on the cultural context of the system.

vi) *Treatment of revenues*

Revenues, reflecting projected demand and tariff/price levels, are included in the cashflow when they are incurred. Adjustment is made for inflation of each component where practical.

2) Net Revenues

Net Revenues are normally the "bottom line" of the cashflow, and assessment of the project is carried out at this point. However, in certain cases other "lines"

must be added to the analysis. Taxation, in particular, has a great potential impact. As most sanitation authorities are public bodies, taxation is usually not an issue. Where any net revenue is subject to tax however, this will have a significant effect on the return to the authority. In this case all deductions from taxable net revenue should be assessed. The most significant are usually

- i) *Depreciation,*
- ii) *Interest expense, and*
- iii) *Superannuation charges.*

A2.3.5 Assessment

1) Cost Benefit Analysis and Cost Effectiveness Analysis

The financial assessment of a project uses the same basic techniques as economic assessment. These are Cost Benefit Analysis (CBA) and Cost Effectiveness Analysis (CEA). The financial assessment of a project using CBA requires the determination of expenditure and revenue, and these are set out over time in a cashflow format. This format allows the use of CBA techniques and the "return" on the project can be calculated. Where there are no or uncertain revenues, or where given levels of outputs must be attained, CEA can be employed.

The effectiveness of a project can be measured by comparing the expenditure of various projects which will achieve a given set of quantifiable outputs - not necessarily revenues. CEA establishes the least expenditure method of achieving a given project outcome.

2) CBA Techniques

The two techniques used in economic analysis will again be used. These are the Benefit Cost Ratio (BCR) and the Internal Rate of Return (IRR). These techniques both require the use of a cashflow format, and discounting. The choice of appropriate discount rate(s) is a political decision, but if none is suggested the rate applying to similar investments in the private sector, or where there are no similar investments, the prime commercial lending rate are first approximations. Governments may have established standards for acceptable levels for IRRs.

If none exist then a first approximation will be a minimum rate of that return applying to similar investments in the private sector, or the prime rate for bank lending.

3) Sensitivity

As in economic analysis, these tests of the project's assumptions are useful. The same range of tests should

	YEAR																					
	0	1	2	3	4	5	6	7	8	9	10	11	12	13	14	15	16	17	18	19	20	
COSTS																						
1 Capital-expenditure		3,500	1,500	750	1,000	750	1,000	500	500	500	500	500	500	500	500							
2 -shadow price (SCF)		3,150	1,350	675	900	675	900	450	450	450	450	450	450	450	450	0	0	0	230	0	0	0
3 O&M-expenditure	30	40	202	226	240	237	288	320	334	342	345	347	350	353	356	359	359	359	359	359	359	359
4 -shadow price (SCF)	27	36	182	203	216	231	259	288	301	308	311	312	313	320	320	323	323	323	323	323	323	323
5 Other costs (eg land)		600	300	100																		
6 Total costs	27	3,786	1,832	978	1,114	906	1,159	758	751	758	761	762	763	770	320	323	323	323	548	323	323	323
BENEFITS																						
7 Users	40	40	53	65	70	80	85	94	100	104	109	113	118	123	127	130	130	130	130	130	130	130
8 Tariff-target	16																					
9 -actual	4	4	6	8	10	12	14	16	16	16	16	16	16	16	16	16	16	16	16	16	16	16
10 Revenue-actual	160	160	297	320	728	980	1,224	1,504	1,600	1,644	1,744	1,809	1,888	2,000	2,032	2,080	2,080	2,080	2,080	2,080	2,080	2,080
11 -shadow price (SCF)	144	144	267	468	653	804	1,102	1,354	1,440	1,498	1,570	1,627	1,699	1,800	1,829	1,872	1,872	1,872	1,872	1,872	1,872	1,872
12 Other benefits(eg health)	30	30	40	49	53	60	64	71	73	78	82	85	87	94	95	98	98	98	98	98	98	98
13 Total Benefits	174	174	307	517	708	924	1,165	1,424	1,515	1,576	1,631	1,712	1,788	1,894	1,924	1,970	1,970	1,970	1,970	1,970	1,970	2,370
14 NET BENEFITS	147	(3,612)	(1,325)	(462)	(406)	18	6	686	764	818	891	950	1,023	1,124	1,604	1,646	1,646	1,646	1,421	1,646	1,646	2,046
15 BCR @ 6% discount-	1.24																					
16 IERR=	9.21																					

all figures in '000 s
inflation p.a. = 0.01

Capital investment = 12,250
Standard Conversion Factor
(SCF) = 0.9

Table A2.1 Sanitation Investment programme - Economic assessment

be carried out, with the addition of a test of variations in the rate or rates of inflation.

4) CEA Techniques

Cost Effectiveness Ratios measure the Present Value of Expenditures incurred to achieve given levels of outputs. These outputs must achieve minimum levels. The least cost projects which achieves the minimum levels should be the one chosen. The same difficulties as identified in economic analysis occur with this approach when widely differing outputs are derived from projects. The need for trade offs among outputs raises the very difficult issue of weighting of these outputs

Sensitivity analysis should be carried out to determine the sensitivity of the ratios to changes in expenditures and outputs.

PRIORITIZATION

Financial prioritization is conceptually easier than that applied to economic analysis. In theory, any investment that makes an acceptable rate of return is financable, and therefore worth undertaking.

Difficulties arise when the high financial return, say to a municipality, is dependent on a subsidy from the central government. The project may not be financially attractive (even if economically justified) to the central government. Problems of administration may also constrain the number of projects which can be implemented.

The same techniques used for cross-sectoral prioritization (see *Section A2.2.5*), involving assessment of projects against agreed criteria, are required to prioritize in these more complex cases

A2.3.6 Monitoring

Monitoring of financial flows is essential to the viability of the project. Key elements requiring effective monitoring systems are

- Times of critical cashflow (when revenues and expenditures are similar) and provision made for such risks,
- The targets for expenditures e.g. wages, number of users, total revenues, levels of tariff etc , and;

- The target levels and timing of expenditures and revenue enhancement measures (higher taxes and/or fees)

After an appropriate time, the performance of the project should be evaluated against the projected performance. Central monitoring of implementing organisations, especially where central government loans or subsidies are involved, is often required, and will use this financial data

A2.3.7 Example

An example of an financial analysis is shown in *Table A2.2* which is at the end of this Appendix. This example uses the same project described in *Section A2.2* and which is subjected to an economic analysis in *Table A2.1*.

Our analysis is carried out to find the financial return to the local government which must finance the periods of negative cashflow from reserves (line 13).

As seen from *Table A2.2*, the two major divisions of a financial analysis cashflow are Expenditure and Revenue. These are set out over the assessment period of 20 years. Our example shows capital expenditures in line 1. These expenditures are adjusted for inflation of 6% in line 2, and the cumulative debt service obligations of the project are shown in line 3.

Line 4 shows total O&M expenditures. These are adjusted for inflation in line 5. Note that the debt service obligations in line 3 are derived from the Finance Cost table at the bottom of the page. Each yearly capital expenditure is assumed eligible for a loan at 10% interest over a 25 year period. Note also that the amounts of each yearly loan are given by the inflated capital costs in line 2. The yearly total of these loan repayments at the bottom of the Finance Cost table is the same as the amounts shown in line 3.

Table A2.2 shows revenues on line 11. These are derived from the projection of demand on line 7 and the tariff rates adjusted for inflation on line 10. The constant cost tariffs shown on line 9. The BCR (line 15) is the ratio of the Present Value of line 11, Total Revenue, to the Present Value of line 6, Total Expenditure. The IRR (line 16) is calculated on Net Revenue to Local Government (line 14).

	YEAR																					
	0	1	2	3	4	5	6	7	8	9	10	11	12	13	14	15	16	17	18	19	20	
EXPENDITURE																						
1 Capital expenditure		3,500	1,500	750	1,000	750	1,000	500	500	500	500	500	500	500	500	500	500	500	500	500	500	
2 -inflated cost		3,500	1,590	843	1,191	947	1,338	709	752	797	845	893	949	1,006	0	0	0	250	0	0	0	
3 -finance cost		386	561	654	785	889	1,037	1,115	1,198	1,285	1,378	1,477	1,582	1,692	1,692	1,692	1,692	1,762	1,762	1,762	1,762	
4 O&M expenditure	30	40	202	226	240	257	289	320	334	342	345	347	350	353	356	359	359	359	359	359	359	
5 -inflated cost	30	40	214	254	286	324	383	454	502	545	583	621	664	714	759	812	866	912	967	1,025	1,086	
6 Total expenditure	30	426	775	908	1,071	1,214	1,422	1,569	1,700	1,830	1,961	2,098	2,246	2,407	2,452	2,504	2,553	2,674	2,729	2,787	2,849	
REVENUE																						
7 Users	40	40	53	65	70	80	83	94	100	104	109	113	118	123	127	130	130	130	130	130	130	
8 Tariff-target/(user/yr)	16																					
9 -actual	4	4	4	8	10	12	14	16	16	16	16	16	16	16	16	16	16	16	16	16	16	
10 -inflated	4	4	6	9	12	15	19	23	24	26	27	29	30	32	34	36	38	41	43	46	48	
11 Revenue	160	160	315	584	867	1,212	1,638	2,133	2,406	2,652	2,946	3,238	3,584	4,024	4,334	4,703	4,985	5,284	5,601	5,937	6,293	
12 NET REVENUE	130	(266)	(460)	(323)	(204)	(2)	216	565	706	822	985	1,139	1,338	1,618	1,882	2,199	2,432	2,610	2,872	3,150	3,445	
13 RESERVES	0	266	460	323	204	2	0	0	0	0	0	0	0	0	0	0	0	0	0	0	0	
14 NET REVENUE TO LOCAL GOV	130	(266)	(460)	(323)	(204)	(2)	216	565	706	822	985	1,139	1,338	1,618	1,882	2,199	2,432	2,610	2,872	3,150	3,445	
15 BCR @ 8% discount=	1.46																					
16 IRR=	31.42																					
FINANCE COST (Line 3 above) - LOAN REPAYMENTS																						
For Years:	In Years:	0	1	2	3	4	5	6	7	8	9	10	11	12	13	14	15	16	17	18	19	20
1			386	386	386	386	386	386	386	386	386	386	386	386	386	386	386	386	386	386	386	
2				175	175	175	175	175	175	175	175	175	175	175	175	175	175	175	175	175	175	
3					93	93	93	93	93	93	93	93	93	93	93	93	93	93	93	93	93	
4						131	131	131	131	131	131	131	131	131	131	131	131	131	131	131	131	
5							104	104	104	104	104	104	104	104	104	104	104	104	104	104	104	
6								147	147	147	147	147	147	147	147	147	147	147	147	147	147	
7									78	78	78	78	78	78	78	78	78	78	78	78	78	
8										83	83	83	83	83	83	83	83	83	83	83	83	
9											88	88	88	88	88	88	88	88	88	88	88	
10												93	93	93	93	93	93	93	93	93	93	
11													99	99	99	99	99	99	99	99	99	
12														105	105	105	105	105	105	105	105	
13															0	0	0	0	0	0	0	
14																0	0	0	0	0	0	
15																	0	0	0	0	0	
16																		0	0	0	0	
17																			0	0	0	
Total Repayments	0	386	561	654	785	889	1,037	1,115	1,198	1,285	1,378	1,477	1,582	1,692	1,692	1,692	1,692	1,762	1,762	1,762	1,762	

all figures in '000's
inflation = 6%

Table A2.2 Sanitation investment programme - Financial assessment.

Capital investment = 12,250
Loan term = 25 yrs
Interest rate p.a. = 10%

Glossary

Aerobic	In presence of oxygen. By aerobic treatment is meant the biological oxidation of organic matter in the waste water by microorganisms.
Anaerobic	In absence of oxygen. Anaerobic treatment is the biological breakdown of organic matter in absence of oxygen. See <i>Section 3.2</i> .
Attached growth	Biomass is growing attached to some carrier material, like in a trickling filter or rotating biological contactor
BOD	Biological Oxygen Demand. An indication of the concentration of biological degradable matter in the waste water. Expressed in mg/L. (Oxidation of reduced nitrogen is not included.)
Black waste water	Toilet waste water, faeces, urine, water used for cleansing and flushing.
COD	Chemical Oxygen Demand. Indication of the total amount of chemically degradable organic matter in the waste water. Expressed in mg/L. Reduced nitrogen is not included.
Combined sewer	Sewer designed or used for the discharge of waste water as well as storm water.
Communal systems	Waste water collection and treatment facilities, designed to treat the waste water of 10-100 households. Households have their own private toilets, connected to the communal tank by a small sewer system.
Community participation	Participation of beneficiaries in the choice, implementation and management of sanitary facilities. Community participation should improve the acceptance and bring down the financial costs.
Conventional sewerage	Sewer systems, designed along conventional European and American standards with respect to gradient, diameter and depth.
DM	Abbreviation of Dry Matter (expressed as weight). Equivalent to dry solids
Drain	Gutter or canal that serves originally for the discharge of storm water, often misused as a sewer.

Economic costs	Costs as seen from the point of view of the entire economic community, usually the nation
Efficiency	Percentage removal of pollutants in waste water by a treatment.
Effluent	Outcoming flow of waste water. The flow of treated waste water as it leaves the treatment plant is usually meant. However, with "industrial effluent" the flow of raw waste water as it leaves the factory is meant: the used process water. From the point of view of the treatment plant we call it influent.
Eutrophication	Enrichment of a surface water body with nutrients necessary for growth of algae (usually phosphorus and nitrogen are meant). Eutrophication can lead to excessive algal bloom; the result is the degradation of the ecosystem and a lesser suitability for drinking water supply, recreation, fishing.
Financial costs	Costs as seen from the point of view of the organisation/actors in a project
Grey waste water	All waste water, produced in toilet as well as kitchen or bathroom
Influent	Incoming flow of waste water
Institutional aspects	All aspects regarding planning and management of the sanitation structures and activities.
Kjeldahl-nitrogen N_{kj}	Nitrogen present in a reduced form (ammonia, amines and organic nitrogen), and thus representing a certain oxygen demand.
Maintenance	All activities to keep the sewer system and treatment plant in a good shape.
Micro-pollutants	Contaminants, toxic in low concentrations, like heavy metals and pesticides.
Net Present Value	Total Benefits from a project over the entire lifespan, translated to the current price level (reckoning with inflation and interest)
NOD	Nitrogen Oxygen Demand. Amount of oxygen necessary for the oxidation of the reduced nitrogen.
Nutrients	Chemical substances necessary for all biological growth. Here nitrogen and phosphorus, the nutrients that limit algal growth are usually meant. Excess of these nutrients in the surface water can cause algal bloom.

Off-site	Away from the residential area: off-site disposal means that by means of a sewer system waste water is transported out of the housing environment.
On-site	On-site disposal means that the waste water is treated or disposed of, in or around the house, in the direct living environment.
Operation	Operation concerns the daily activities at the treatment plant to maintain a satisfying treatment process.
Pathogens	Micro-organisms (helminths, protozoa, bacteria, viruses) that can cause a disease in man or animal. Many pathogens are spread by human excreta and therefore waste water can contain large amounts of viruses, bacteria and helminth eggs.
Public facilities	Public toilet facilities, serving 2-50 households that do not dispose of own toilets.
Sanitation	Management of human waste, especially human excreta.
Separate sewer	Sewer system designed for the discharge of waste water only. Storm water is discharged in another way, e.g. drains.
Sewage	The waste water as it is collected in the sewer system. domestic waste water with possibly infiltration water, drain water and sometimes industrial effluent.
Shallow sewer	A sewer system, laid on ground level, usually with reduced diameter. Simple to construct and maintain but vulnerable.
Shared system	Waste water collection and/or treatment facilities, serving 2-10 households. Each household has its own private toilet with an individual connection to the disposal facility.
Sludge load	Amount of BOD (or COD) applied per unit of active biomass in the treatment reactor.
Small-bore sewer	Sewer system with reduced diameter and closed joints. Suitable for the transportation of waste water, not containing settleable solids. Requires solids and fat traps.
Socio-cultural aspects	Aspects regarding attitude, habits, religion and preferences of the users of sanitary facilities (and of the authorities!).
Sullage	Waste water flow originating from household activities: cooking, laundering, washing, bathing. Toilet waste is not included.

Suspended growth	Configuration (of a reactor) in which the active biomass is suspended in the liquid, and not attached to a carrier, <i>e.g.</i> activated sludge or UASB.
UASB	Upflow Anaerobic Sludge Blanket Reactor type for the anaerobic treatment of waste water. See <i>Chapter 3</i> .

Literature

Alaerts, G.J., D. Wilms & A. van Haute (1982). Chemical and Hydraulical Characteristics of the Complex Sewerage of a Large, Densely Populated Area Proc. 2nd A.P.R. Conf. Int. Hydr. Ass., Bandung. Paper BP4, Aug. 1982.

Alaerts, G.J., J.M. Dave, R.H. Siddiqi, W. van Starckenbürg, T. Chakrabarti, S.C. Kudesia & K. Mohan (1989). Final Report of the Joint Appraisal Mission for 5 MLD UASB plant Kanpur. Ganga Project Directorate, Government of India; Ministry of Foreign Affairs, Government of the Netherlands; New Delhi 14 pp + annexes.

Anaerobic Digestion (1988). Proc. 5th Int. Symposium on Anaerobic Digestion. Bologna, Italy E.R. Hall & P.N. Hobson (Eds.). Pergamon Press, Oxford. 517 pp

Anaerobic Treatment. A Grown-up Technology (1986). Conference Papers Aquatech '86. Industrial Presentations Group, Schiedam. 788 pp.

Arceivala, S.J. (1981) Wastewater Treatment and Disposal. Engineering and Ecology in Pollution Control. Marcel Dekker, New York. 890 pp

Arthur, J.P. (1983): Notes on the Design and Operation of Waste Stabilisation Ponds in Warm Climates of Developing Countries The World Bank Studies in Water Supply and Sanitation no 7 World Bank, Washington D.C. 106 pp.

Awananto, V.F. (1989): Appropriate Sanitation Systems for Indonesian Urban Areas. M.Sc. thesis report no EE 18, IHE, Delft. 112 pp + annexes.

Brown, N.L. and P.B.S. Tata (1985): Biomethanation. Environmental Sanitation Reviews no 17/18. ENSIC, Bangkok. 168 pp.

Cairncross, S. and R. Feachem (1983): Environmental Health Engineering in the Tropics, J. Wiley & Sons, Chichester. 283 pp.

CBPCWP - Central Board for the Prevention and Control of Water Pollution (1979) Waste Water Collection, Treatment and Disposal in Class I Cities. New Delhi. 55 pp

CBPCWP - Central Board for the Prevention and Control of Water Pollution (1980). Status of Water Supply and Waste Water Collection, Treatment and Disposal in Class II Towns of India. New Delhi. 76 pp.

Chantana Chanond (1987): Recent Changes in the Land Market on Urban Fringe of Bangkok. ITC Journal (1987), no 3, p 211-212.

Department of Public Works and Highways (1987). Water Supply, Sewerage, and Sanitation Master Plan of the Philippines 1988-2000. Manila. 117 pp.

Derycke, D., and W. Verstraete (1986). Anaerobic Treatment of Domestic Wastewater in a Lab and Pilot Scale Polyurethane Carrier Reactor. In Anaerobic Treatment. A Grown-up Technology. Conference Papers Aquatech '86, Amsterdam. p 440-450.

Directorate-General of Human Settlements (1987). Guidelines for Integrated Urban Infrastructure Development (UIIDP) Programme Preparation 1988/89. Directorate-General of Human Settlements, Jakarta, Indonesia.

ENSIC (1982) Septic Tanks and Septic Systems. Environmental Sanitation Reviews, no 7/8. ENSIC, Asian Institute of Technology, Bangkok. 110 pp

Euroconsult, DHV Consulting Engineers and Agrovisión Holland (1988): Rada' Water Supply and Sanitation Project, Vol 1, Main Report.

Feachem, R.G., D.J. Bradley, H. Garelick and D.D. Mara (1983) Sanitation and Disease: Health Aspects of Excreta and Wastewater Management. World Bank Studies in Water Supply and Sanitation 3. World Bank, Washington D.C. 501 pp.

Field, J (1988): Biodegradability and Toxicity. Lecture Series Held for IHE, Dept of Water Pollution Control, Agricultural University Wageningen. Approx. 60 pp

Frostell, B. (1981): Anaerobic Treatment in a Sludge Bed System Compared with a Filter System J. Wat. Poll. Contr. Fed., 53, p 216-222.

Gopal, B. (1987): Water Hyacinth. Elseviers, Amsterdam 471 pp

Gujer, W. and A J.B Zehnder (1983): Conversion Processes in Anaerobic Digestion. Wat. Sci. Tech., 15, p 127-167.

Graaf, J.H.J. van der, F.A. Fastenau and A.H.M. van Bergen (1988) Individual Treatment of Waste Water for Disperse Housing. (in Dutch) Ministerie van Volkshuisvesting, Ruimtelijke Ordening en Milieuhygiene, Leidschendam. 246 pp

Haskoning, AUW, Univalle and Incol (1985): Anaerobic Treatment and Reuse of Domestic Wastewater. Pilot Plant Study, Cali, Colombia. Final Report. Haskoning Royal Dutch Consulting Engineers, Nijmegen; Agricultural University Wageningen; Universidad del Valle, Cali; INCOL Ingenieros Consultores LTDA, Cali.

Haskoning, AUW and Emcali (Haskoning Royal Dutch Consulting Engineers, Agricultural University Wageningen, Empresas Municipales de Cali) (1989): Anaerobic Treatment of Domestic Wastewater under Tropical Conditions. Final Report Pilot-Plant Research. Haskoning Royal Dutch Consulting Engineers, Nijmegen 106 pp + annexes.

Haskoning (1989): Design, Construction, Maintenance (Decom). Manual for UASB reactors for Domestic Wastewater under Tropical Conditions (Draft) Haskoning Royal Dutch Consulting Engineers, Nijmegen.

Haskoning, Euroconsult, AIC and Iramconsult (Haskoning Royal Dutch Consulting Engineers, Euroconsult Engineers, AIC, Iramconsult) (1987): Environmental and Sanitary Engineering Project, Kanpur-Muzapur, Under Ganga Action Plan. Inception Report, Volume 2. Haskoning Royal Consulting Engineers, Nijmegen

Henze, M. and P Harremoës (1983) Wat. Sci. Techn., 15, no 8/9, p 1-100

Incol (Ingenieros Consultores Ltda, Cali) (1988). Unpublished data on construction costs of UASB treatment plants in Colombia.

IHE, AUW and St. Borromeus (International Institute for Hydraulic and Environmental Engineering, Agricultural University Wageningen and General Hospital St. Borromeus) (1989) Upflow Anaerobic Sludge Blanket, Low Cost Sanitation Research Project in Bandung, Indonesia. First progress report, Extension phase. IHE, Delft. 14 pp

IHE, AUW and St. Borromeus (International Institute for Hydraulic and Environmental Engineering, Agricultural University Wageningen and General Hospital St. Borromeus) (1990). Upflow Anaerobic Sludge Blanket, Low Cost Sanitation Research Project in Bandung, Indonesia. Final report, IHE, Delft (in preparation).

IRC-International Reference Centre for Water Supply and Sanitation (1986): Small Communities Water Supplies, Technology of Small Water Supply Systems in Developing Countries, Technical Paper no 18 J. Wiley, Chichester/New York. 442 pp.

IUIDP-Integrated Urban Infrastructure Development Programme (1988): Klasifikasi Prasarana Perkotaan. Tim Koordinasi Pembangunan Perkotaan, Jakarta, 63 pp.

Jakma, F.F.G.M., C.J. Collazos and A. Schellinkhout (1987). Application of Anaerobic Sewage Treatment in Subtropical Countries. (in Dutch) H₂O, 20, 1, p 2-5.

Jewell, W.J. (1985). The Development of Anaerobic Wastewater Treatment. Proc. of the Seminar/Workshop "Anaerobic Treatment of Sewage", June 27 and 28, Univ of Mass, Amherst, Mass. (ed M.S. Switzenbaum), p 17-54.

Joshi, R.N., G.P. O'Mellow, N.V. Pai and M.R. Naik (1987): Pilot Scale Experiment with Anafil Digestor. Civil Training Institute & Research Centre Borisali, Mumbai, India. 15 pp

Jovanovic, M., K.L. Murphy and E.R. Hall (1986): Parallel Evaluation of High-rate Anaerobic Treatment Processes: Retention Time and Concentration Effects. Anaerobic Treatment, A Grown-up Technology, Conference Papers Aquatech '86, Amsterdam. p 145-158.

Jürgensen, H. (1982): Ablaufergebnisse an unbelüfteten Abwasserteichen in Schleswig-Holstein. Wasser und Boden, 5, p 193-200

Kalbermatten, J.M., D.S. Julius and C.G. Gunnerson (1978): Appropriate Sanitation Alternatives, A Planner's Guide. World Bank Studies in Water Supply and Sanitation. World Bank, Washington D.C.

Kalbermatten, J.M., D.S. Julius and C.G. Gunnerson (1982). Appropriate Sanitation Alternatives: A Technical and Economical Option World Bank Studies in Water Supply and Sanitation, no 1. World Bank, Washington D.C. 111 pp.

Koster, I.W. and A. Rinzema (1984): Toxicity and Adaptation in Anaerobic Processes. (in Dutch). H₂O, 17, 24, p 575-581, 585.

Kruijff, G.J.W. de (1985a). Technical Report on Project Findings and Recommendations, Prepared for the Government of Indonesia. (United Nations Development Programme, INS/81/002) Institute of Human Settlements, Agency for Research and Development, Ministry of Public Works, Bandung, Indonesia. 16 pp.

Kruijff, G.J.W. de (1985b): The Design of Septic Tank Systems with Effluent Disposal Options. (final draft), Urban Sanitation Investment Report. Institute of Human Settlements, Agency for Research and Development, Ministry of Public Works, Bandung, Indonesia. 110 pp

Kruijff, G.J.W. de, and A.J. Macoun (1988). Sanitation Improvements for High Groundwater or Tidal Areas. UNDP INS/84/005. Cipta Karya, Jakarta. 21 pp.

Laak, R. (1986): Wastewater Engineering Design for Unsewered Areas. Technomic Publishers Co., Pen. USA. 167 pp.

Lager, J.A. & W.S. Smith (1974): Urban Stormwater Management and Technology. An Assessment. U.S. Environmental Protection Agency, Cincinnati 84 pp

Lettinga, G., L.W. Hulshoff Pol, I.W. Koster, W.M. Wiegant, W.J. de Zeeuw, A. Rinzema, P.C. Grün, R.E. Roersma and S.W. Hobma (1984): High-Rate Anaerobic Waste-Water Treatment Using the UASB Reactor under a Wide Range of Temperature Conditions Biotechnology and Genetic Engineering Reviews, 2, p 253-284.

Lewis, W.J., S.S.D. Forster and B.S. Drasar (1982): The Risk of Groundwater Pollution by On-site Sanitation In Developing Countries, IRCWD, Duebendorf, Switzerland. 79 pp

Macoun, A J (1988) Human Waste Disposal Technology Options. UNDP Programme INS/84/005. Urban Sanitation Investment Support. Cipta Karya, Jakarta, Indonesia. 10 pp.

Man, A.W.A. de. and G Lettinga (1987) Anaerobic Sewage Treatment at Low Temperatures (in Dutch) H₂O, 20, 25, p 640-644.

Man, A.W.A. de, P.C. Grin, R.E. Roersma, K.C.F. Grolle and G. Lettinga (1986). Anaerobic Treatment of Municipal Wastewater at Low Temperatures. Anaerobic Treatment. A Grown-up Technology. Conference Papers, Aquatech '86, Amsterdam. p 453-466.

Man, A.W.A. de, A.R.M. van der Last and G Lettinga (1988): The Use of EGSB and UASB Anaerobic Systems for Low Strength Soluble and Complex Wastewaters at Temperatures Ranging from 8 to 30 °C. Proc. 5th Int. Symposium on Anaerobic Digestion. Bologna, Italy E.R. Hall & P.N. Hobson (Eds.). Pergamon Press, Oxford

Metcalf & Eddy (1984): Wastewater Engineering: Treatment, Disposal and Reuse. Tata McGraw Hill Publ. Co., New Delhi and New York. 920 pp.

Ministerie van de Vlaamse Gemeenschap (1985), Alternative Waste Water Treatment (in Dutch) Min. of the Flemish Community, Brussels p 45-51.

Ministerio do Desenvolvimento Urbano e Meio Ambiente (1986): Resolucao no. 20, de 18 de Junho de 1986. Ministerio do Desenvolvimento Urbano e Meio Ambiente, Brasilia, Brasil.

Neel, J.K., J.H. McDermott, C.A. Monday jr. (1961): Experimental Lagooning of Raw Sewage at Fayette, Missouri. J. Wat. Poll. Contr. Fed. 33, p 603-641

Orozco, A. (1988): Anaerobic Wastewater Treatment Using an Open Plug Flow Baffled Reactor at Low Temperature. Proc. 5th Int. Symposium on Anaerobic Digestion, Poster papers edited by A. Tilche and A. Rozzi.

Orth, H., Lertpocasombut and P.A. Wilderer (1987) Wastewater Treatment for Industrial Estates in Southern Asia Using Waterhyacinths. Wat. Sci. Techn. 19, p 85-96.

Orth, H. (1988): A Comparison of Alternative Sanitation Options Applied to a Medium-sized Town. Anaerobic Waste Treatment and Sanitation Technologies. Seminar organized by the Asian Institute of Technology, Bangkok, Thailand. 1-3 September 1988

Pickford, J (1980): The Design of Septic Tanks and Aqua-privies. Overseas Building Notes, Loughborough 11 pp.

Reddy, J. and M. Debusk (1987) Wat. Sci. Techn. 19, no 10, p 61-80.

Rietveld, C. (1988). Water Supply and Sanitation in Fast Growing Cities. Monograph, Washington D.C. 20 pp.

RIVM, AUW and St. Borromeus (Nat. Inst. Public Health and Envir. Hyg., Agricultural University Wageningen and General Hospital St. Borromeus) (1988) Upflow Anaerobic Sludge Blanket (UASB) Low Cost Sanitation Research Project in Bandung, Indonesia. Final Report. Rijksinstituut voor Volksgezondheid en Milieuhygiëne, RIVM, Bilthoven. 90 pp + appendices.

Sanz, I. and F. Fdz-Polanco (1990): Low Temperature Treatment of Municipal Sewage in Anaerobic Fluidized Bed Reactors Wat. Res. 24, 4, p 463-469.

- Schellinkhout, A. (1987): Sewage Treatment Plant "Rio Frio", Bucaramanga, Colombia, DHV Consulting Engineers, Amersfoort. 8 pp.
- Schellinkhout, A. (1988) Anaerobic Sewage Treatment in the Tropics TCA Workshop Results, DHV Consulting Engineers, Amersfoort. 3 pp
- Silva, S.A.S. (1982): On the Treatment of Domestic Sewage in Waste Stabilization Ponds in North-East Brazil. PhD-thesis, University of Dundee.
- Sinclair, Knight & Partners (1989): Regional Cities Development Project, Prefeasibility Studies, Bangkok, 271 pp.
- Sinha, B.D and A.K Ghosh (1990). Evaluation of Low Cost Sanitation. Arnold Publ., New Delhi. 144 pp.
- Sinnatamby, G., D. Mara and M McGarry (1986): Shallow Systems Offer Hope to Slums. World Water, Jan/Feb 86. p 39-41.
- Specker, H. and J.L. van Buuren (1988): Mission Report. Pre-feasibility Appraisal Wastewater Treatment Project in Nicaragua. Nederlands Economisch Instituut, Rotterdam. 77 pp
- Specker, H (1987): Mission Report on Economic Aspects of the Environmental and Sanitary Engineering Project: Kanpur, Mirzapur Nederlands Economisch Instituut, Rotterdam 33 pp
- Stichting Agromisa (1984): Biogas, The Brown Revolution? Social Aspects of Introducing Biogas Technology in Developing Countries, with Special Emphasis on the Potentials and Consequences for the Rural Poor. Stichting Agromisa, Wageningen; Vereniging Nederland-China, Utrecht 117 pp.
- STORA (1988): Choices and Costs in Sewage Treatment Plants in Function of Effluent Requirements. (in Dutch). Stichting Toegepast Onderzoek Reiniging Afvalwater (Stora), Den Haag 94 pp
- Switzenbaum, M.S. (1985). Proceedings of the Seminar/workshop Anaerobic Treatment of Sewage. June 27 and 28, 1985, at Univ. of Mass., Amherst, Mass 385 pp.
- Times Atlas of the World (1985) Times Books Ltd., London
- Trentelman, C.C.M. (1981): Statistical Treatment of Effluent Data of Dutch Sewage Treatment Plants (in Dutch). DHV Consulting Engineers, Amersfoort 113 pp. + annexes.
- Veenstra, S. (1988): Lecture notes: Sanitation Technologies. International Course in Low Cost Water Supply and Sanitation. IHE, Delft. 80 pp.
- Verhaegen, K., K. Van Rompu and W. Verstraete (1989). Pretreatment of Sewage by Means of a Polyurethane Parallel Plate Separator. Trb. Cebedeau, 42, 4. p 52-57
- Vieira, Sonia M.M (1988): Anaerobic Treatment of Domestic Sewage in Brasil, Research Results and Full-scale Experiments Proc. 5th Int. Symposium on Anaerobic Digestion, Bologna, Italy. Ed. E.R. Hall & P.N. Hobson. p 185-196.
- Wijlhuizen, E and C. Nelissen (1983). Design Criteria for Biodiscs. (in Dutch), H₂O, 16, 21, p 470-473.
- Witteveen+Bos (1988). Cost Assessment of Anaerobic (Pre-)Treatment of Sewage (in Dutch). Werk no LIS57.1, HA/70. Witteveen+Bos, Deventer 34 pp + annexes
- Witteveen+Bos (1989): Addendum to "Witteveen+Bos (1988)." Pers. comm.

WHO-World Health Organisation (1981) Drinking Water and Sanitation, 1981-1990, a Way to Health. WHO, Geneva, 1981. 56 pp

WHO-World Health Organisation (1984): Guidelines for Drinking Water Quality, Volume I, Recommendations. WHO, Geneva.

WHO-World Health Organisation (1987): The International Drinking Water Supply and Sanitation Decade, Review of the Mid-decade Progress (As at December 1985). CWS Unit, Division of Environmental Health, WHO, Geneva. 218 pp.

WHO-World Health Organisation (1989). Health Guidelines for the Use of Wastewater in Agriculture and Aquaculture, Technical Report Series 978. WHO, Geneva. 74 pp

Report Series

of the International Institute for Hydraulic and Environmental Engineering

Number	Year	Author	Title
1	1966	G.S. Rodenhuis	The undular hydraulic jump
2.	1968	Prof.dr. M.B. Abbott and E.W. Lindemijer	Two transients for a radial nearly-horizontal flow
3.	1968	Prof.dr. M.B. Abbott, G. Marshall and T. Ohno	On weak solutions of the equations of nearly-horizontal flow.
4.	1968	A.N. Jolliffe	The investigation of systems of regular channels of the general type occurring in catchments.
5	1968	Prof.dr. M.B. Abbott	Computational hydraulics
6	1968	F.H. Verhoog	A numerical method for computation of flood waves in rivers.
7	1969	Prof.dr. J.W.M. la Rivière	The role of the microbiologist in the control of human environment, new approaches to waste treatment and water recovery
8.	1969	Prof.dr. M.B. Abbott and A. Verweij	The four-point method of characteristics
9	1969	C.J. Vaillant	L'Ozonation et la filtration lente dans le problème de la prolifération microbienne dans les réseaux de distribution d'eau
10.	1970	Prof.dr. M.B. Abbott and G.S. Rodenhuis	On the formation and the stability of the undular hydraulic jump.
11	1970		Working seminar on the course in environmental science and technology
12.	1971	A. Verweij	Mathematical model for flow in rivers with realistic bed configuration.
13	1975	Prof. L. Horst	Groundwater abstraction by gravity from sand rivers.
14	1977	D.O. Hodgins	On certain aspects of a numerical model for three-dimensional stratified flows
15	1982	Prof.dr. M.B. Abbott	Modelling of turbulent flows
16	1985	Dr. P.J.M. de Laat	MUST, a simulation model for unsaturated flow
17	1987	N.D. Mahmoudzadeh	Mathematical model of Anzali lagoon in the Islamic Republic of Iran
18	1988	R. Murray	A numerical wave model based on new equations of Boussinesq type which can incorporate improved dispersion characteristics
19	1990	W. van Vierssen and H.G. Wind	Rivers, natural and dynamic. Towards an integrated management of the Rhine River basin. (in Dutch)

11

12

13

14

15

16

17

IHE 
D E L F T

P.O. Box 3015
2601 DA Delft
The Netherlands