

# Best Practice Recommendations for Local Manufacturing of Ceramic Pot Filters for Household Water Treatment



The Ceramics Manufacturing Working Group  
*June 2011*  
*First Edition*



Recommended Citation: The Ceramics Manufacturing Working Group (2011). *Best Practice Recommendations for Local Manufacturing of Ceramic Pot Filters for Household Water Treatment, Ed. 1*. Atlanta, GA, USA: CDC.

Cover photos (clockwise from top left): Family using the ceramic filter in Nicaragua (D. Lantagne); Potters for Peace filter (D. Lantagne); Filters for distribution, Myanmar (ThirstAid); and, Filter user, Kenya (K. Wagoner). Used with permission.

Best Practice Recommendations for  
Local Manufacturing of Ceramic Pot Filters  
for Household Water Treatment

The Ceramics Manufacturing Working Group  
June 2011  
First Edition

This report is dedicated to the memory of  
Ron Rivera and Mickey Sampson  
who worked tirelessly to promote ceramic water filtration.



# CONTENTS

1	Introduction .....	15
2	Literature Review .....	18
	2.1 Filter Efficacy .....	18
	2.2 Social Acceptability .....	22
	2.3 Mechanisms of Effectiveness .....	23
	2.4 Summary .....	27
3	Overview of Filter Production: Survey Results.....	28
	3.1 Survey Development and Limitations .....	28
	3.2 Results.....	30
	3.3 Materials .....	33
	3.4 Additional Materials .....	34
	3.5 Ratio and Mixing.....	34
	3.6 Forming Filter Elements.....	35
	3.7 Stamping, Surface Finishing, and Drying.....	36
	3.8 Firing.....	37
	3.9 Silver.....	37
	3.10 Quality Control .....	39
	3.11 Health and Safety .....	42
	3.12 Summary .....	43
4	Variables: Materials Sourcing and Processing .....	45
	4.1 Water .....	45
	4.2 Clay.....	46
	4.3 Clay Processing.....	52

4.4	Burn-out Material .....	55
4.5	Burn-out Material Processing.....	55
4.6	Additional Materials and Processing.....	57
4.7	Material Evaluation, Documentation, and Storage.....	58
4.8	Recommendations.....	59
4.9	Areas for Further Research .....	59
4.10	Chapter Details.....	60
<b>5</b>	<b>Variables: Filter Production.....</b>	<b>61</b>
5.1	Production Logs.....	61
5.2	Establishing Filter Mixture Ratio .....	61
5.3	Filter Mixture Preparation.....	63
5.4	Wedging, Pounding, Kneading, Pug Mill.....	65
5.5	Press.....	65
5.6	Mold.....	66
5.7	Mold Release.....	67
5.8	Pressing.....	67
5.9	Surface Finishing, Stamping, and Drying.....	68
5.10	Recommendations.....	70
5.11	Areas for Further Research .....	71
5.12	Chapter Details.....	72
<b>6</b>	<b>Variables: Kilns and Firing .....</b>	<b>73</b>
6.1	Introduction .....	73
6.2	Types of Kilns .....	73
6.3	Fuel Options and Storage.....	74
6.4	The Mani Kiln.....	75

6.5	Monitoring Heatwork and Temperature.....	77
6.6	Firing Log.....	80
6.7	Combustion.....	80
6.8	The Firing Process.....	82
6.9	Recommendations.....	92
6.10	Areas for Further Research .....	93
6.11	Chapter Details.....	93
7	Variables: Silver Nanoparticles (Colloidal Silver).....	95
7.1	Introduction.....	95
7.2	Overview of Proposed Disinfectant Mechanisms of Silver Nanoparticles	96
7.3	Production of Silver Nanoparticles.....	99
7.4	Silver in Ceramic Water Filters .....	101
7.5	Environmental and Health Concerns .....	104
7.6	Silver Application Guidelines .....	104
7.7	Recommendations.....	106
7.8	Areas for Further Research .....	107
7.9	Chapter Details.....	107
8	Variables: Quality Control .....	108
8.1	Introduction.....	108
8.2	Quality Control Program .....	109
8.3	Quality Control of Final Product.....	112
8.4	Recommendations.....	121
8.5	Areas for Further Research .....	122
8.6	Chapter Details.....	122
9	Variables: The Filter Unit and Packaging.....	123

9.1	Filters .....	123
9.2	Receptacle and Lid .....	123
9.3	Taps.....	124
9.4	Additional Items .....	124
9.5	Operation and Maintenance (O & M) Instructions.....	124
9.6	Packaging.....	125
9.7	Recommendations.....	126
9.8	Areas for Further Research .....	127
9.9	Chapter Details .....	127
10	Conclusions .....	128
10.1	Lessons Learned .....	128
10.2	Summary of Best Practice Recommendations.....	130
10.3	Summary of Areas for Further Research .....	134
10.4	Voluntary Nature of Recommendations .....	136
11	Glossary.....	137
12	References .....	140



## Annexes

Annex A. Scope of Work.....	147
Annex B. Conversion Tables .....	149
Annex C. Survey Results Tables.....	151
Annex D. Raw Material Evaluations.....	156
Annex E. Clay Blending Methods .....	159
Annex F. Additional Tests .....	163
Annex G. Sample Production Logs.....	165
Annex H. Silver Dilution.....	173
Annex I. Equipment Information .....	177
Annex J. Materials Suppliers .....	182
Annex K. Sample O&M Instructions.....	185

## List of Figures

Figure 1-1: PFP Filter System .....	15
Figure 3-1: Production Variables .....	29
Figure 3-2: Filter Factory Locations .....	30
Figure 3-3: Monthly Filter Production.....	32
Figure 3-4: CWF Retail Prices .....	32
Figure 3-5: Clay Sieve Sizes .....	34
Figure 3-6: Burn-out Sieve Sizes.....	34
Figure 3-7: Clay-Rice Husk Ratio .....	34
Figure 3-8: Clay-Sawdust Ratio.....	35
Figure 3-9: Filter Shapes .....	36
Figure 3-10: Drying Times .....	37
Figure 3-11: Flow Rate Ranges.....	40
Figure 3-12: Failure Rates .....	41
Figure 3-13: Filters Cracked During Firing.....	42
Figure 3-14: Filter Production Flow Chart.....	44
Figure 4-1: Elephant's Foot Tamper .....	53
Figure 4-2: Hammermill Diagram.....	54
Figure 4-3: Hammermill Screen.....	54
Figure 4-4: Burn-out Sifter .....	56
Figure 5-1: Drum Mixer.....	64
Figure 5-2: Pug Mill.....	65
Figure 5-3: Filter Press with Aluminum Mold, Indo-2.....	65
Figure 5-4: Filter Press with Cast-iron Mold, Cam-1.....	65
Figure 5-5: Filter Press with Wooden Mold, Myanmar.....	66
Figure 5-6: Filter Press with Cement Mold, DR .....	66
Figure 5-7: PFP Dutch Press.....	66
Figure 5-8: Checking Mold Alignment.....	67
Figure 5-9: Uneven Drying.....	69
Figure 6-1: Heat Flow in an Updraft Kiln.....	73
Figure 6-2: Heat Flow in a Downdraft Kiln .....	73

Figure 6-3: Firing with Oil, Thailand.....	75
Figure 6-4: Oil Plate, Thailand.....	75
Figure 6-5: Flat Top Mani Kiln.....	76
Figure 6-6: Mani Kiln Cross Section.....	77
Figure 6-7: Cone Block.....	78
Figure 6-8: Digital Pyrometer.....	79
Figure 6-9: Protection Tube (top) and Thermocouple (bottom).....	79
Figure 6-10: Draw Trials and Cones in Stacked Kiln.....	80
Figure 6-11: Draw Trial Being Removed.....	80
Figure 6-12: Broken Draw Trial with Black Core.....	80
Figure 6-13: Cross Section of Ash Pit and Firebox.....	81
Figure 6-14: Firebox Doors.....	82
Figure 6-15: Firing Curve and Stages of Firing.....	83
Figure 6-16: Flat Bottomed Filters Stacked in a Kiln.....	84
Figure 6-17: Filters Stacked for Firing, Myanmar.....	84
Figure 6-18: Oblong Filters Stacked for Firing.....	84
Figure 6-19: Kiln being Fired, Cam-1.....	85
Figure 6-20: Black Core.....	87
Figure 6-21: Firing Graph, San Mateo Ixtatán, Guatemala (Guate-2).....	90
Figure 6-22: Cracked Filters.....	91
Figure 6-23: Firing/Cooling Crack.....	92
Figure 7-1: Commercial Silver Nanoparticle Products by Category.....	96
Figure 7-2: Proposed Antibacterial Mechanism of Colloidal Silver.....	97
Figure 7-3: Schematic of System used for Electrochemical Reduction of $Ag^+$ to $Ag^0$ .....	100
Figure 8-1: Pressure Test and Evidence of Leaks.....	113
Figure 8-2: Calibrated T-device.....	115
Figure 9-1: Filter Unit with Fitting Ring.....	124
Figure 9-2: Packaged Filters, Myanmar.....	126
Figure 9-3: Packaging Filters, Nicaragua.....	126
Figure 9-4: Packaging Filters, Honduras.....	126
Figure E-2-1 Triaxial Blending Triangle.....	160

## List of Tables

Table 1: Log Reduction Value .....	18
Table 2: Water Quality Risk Levels .....	18
Table 3: Summary of Field Studies .....	20
Table 4: Participating Factories .....	31
Table 5: Colloidal Silver Applied by Brushing .....	38
Table 6: Colloidal Silver Applied by Dipping .....	38
Table 7: Current Application Protocol, Techniques, Products, and Concentration of Silver Nanoparticles in Ceramic Filters .....	101
Table 8: Advantages and Disadvantages of Silver Application Methods .....	102
Table 9: <i>E. coli</i> Removal in Ceramic Filters with and without Silver Application .....	102
Table 10: Silver Release from Ceramic Filters .....	103
Table 11: Quality Control Procedures and Testing Frequency .....	110
Table 12: Recommended In-house Testing Methods .....	118

## Acronyms

3GMK	Third Generation Mani Kiln
Ag <sup>0</sup>	Silver Oxide
CDC	US Centers for Disease Control and Prevention
CFU	Colony Forming Units
EPA	US Environmental Protection Agency
HWTS	Household Water Treatment and Safe Storage
ICAITI	Instituto Centro Americano de Tecnología Industrial (Central American Industrial Technology Institute)
ICP-MS	Inductively Coupled Plasma Mass Spectrometry
K	Kelvin
LRV	Log Reduction Value
MF	Membrane Filtration
MPN	Most Probable Number
NGO	nongovernmental organization
NIST	National Institutes for Science and Technology
NTU	Nephelometric Turbidity Units
O & M	Operation and Maintenance
P/A	Presence/Absence
PFP	Potters for Peace
PPM	Parts per Million
RDI-C	Resource Development International—Cambodia
ROS	Reactive Oxygen Species
RPM	Revolutions per Minute
TC	Total Coliform
TTC	Thermotolerant Coliform (Fecal Coliform)
WHO	World Health Organization

## Acknowledgements

The authors would like to thank the following people for their invaluable assistance in this project including:

Pat Lennon and Jesse Schubert of PATH for their leadership and financial support in bringing this document to completion;

Patty Osborne, Barbara Donachy, Curt & Cathy Bradner, Derek Baker, Alastair Fraser, and Eric Mintz for their review and comments on this document;

Peter Chartrand, Burt Cohen, Robert Pillers, and Manny Hernandez for going above and beyond and so helpfully answering questions during the revision process; and lastly,

Fernando Mazariegos and ICAITI, who developed the filter technology initially.

This work would not have been possible without the collaboration of the members of the Ceramics Manufacturing Working Group, which includes:

Justine Rayner	PATH/Consultant	jsrayners@yahoo.com
Daniele Lantagne, PE	US Centers for Disease Control and Prevention (CDC)	dlantagne@cdc.gov
Lisa Ballantine	FilterPure	lisaballantine@aol.com
Joe Brown, PhD	London School of Hygiene and Tropical Medicine	joe.brown@lshtm.ac.uk
Vinka Craver, PhD	University of Rhode Island	
Burt Cohen	Potters without Borders	burtcohen@potterswithoutborders.com
Terry Foecke		
Tracy Hawkins	SAFE Water Now (SWaN)	tracy.hawkins@safewaternow.org
Manny Hernandez	Professor Emeritus, Northern Illinois University	joliga146@yahoo.com
Stephanie Hooker	National Institutes for Science and Technology (NIST)	
Susan Murcott	Massachusetts Institute of Technology	murcott@mit.edu
Robert Pillers	Potters for Peace	bpillers@gmail.com
Mike Stewart	University of Colorado	michael.w.stewart@colorado.edu

# 1 Introduction

An estimated 884 million people do not have access to an improved water supply (UNICEF/WHO 2008), and hundreds of millions more drink water contaminated at the source or during collection, transport, and storage (Clasen and Bastable 2003). Diarrhea, one health consequence of unsafe drinking water, accounts for 1.87 million (19%) childhood deaths each year (Boschi-Pinto *et al.* 2008).

Ceramic filters have traditionally been used to treat household water in many countries, and are commonly available for purchase in both developed and developing countries. Currently, the most widely promoted household ceramic filters in the developing world are based on a design developed in Guatemala in 1981 by Dr. Fernando Mazariegos who, working with the Instituto Centro Americano de Tecnología Industrial (ICAITI), conceived of the idea of utilizing native artisan skills and traditional use of ceramic pots to design a ceramic water filter that would address the urgent need for access to potable water in rural Central American communities (AFA 1995). After two years of research and field trials, with funding from the Inter-American Development Bank, ceramic water filter units were developed. These filters met the objectives of being produced with local, freely available raw materials, at low cost, using earthenware pottery, and promoting local employment.



Figure 1-1: PFP Filter System

In the mid-1990s, the manufacturing process was redesigned by the US-based nongovernmental organization (NGO) Potters for Peace (PFP). PFP has subsequently promoted filter manufacturing in over 20 countries. The ICAITI/PFP filter design is similar to a flowerpot in shape, holds about 8 liters of water, and is suspended inside a plastic or ceramic receptacle fitted with a tap and a lid (Figure 1-1). Users pour water into the filter, wait for the water to flow through the filter into the receptacle, and dispense filtered water from the tap. The filters are produced in country at ceramics manufacturing facilities.

Recent research in Cambodia has confirmed that locally made ceramic filters improve the microbiological quality of stored water and reduce the frequency of diarrheal disease in users (Brown *et al.* 2007). Based on this and other research, it has been suggested that filters may be the most effective household water treatment option (Sobsey *et al.* 2008). They have also received the highest overall score for appropriateness in the recently published booklet *Smart Disinfection Solutions* (NetherlandsWaterPartnership 2010). Although ceramic filters are a promising household water treatment and safe storage (HWTS) option, many challenges and critical research questions still need to be addressed.

A key challenge is maintaining quality control standards of ceramic filter manufacturing in decentralized production facilities. Experience from another locally produced HWTS option, liquid sodium hypochlorite, has highlighted the importance of ongoing, stringent production and quality control standards to ensure that the sodium hypochlorite produced is appropriate for water treatment (POUZN 2007). Locally manufactured ceramic filters are made by pressing a

mixture of clay and a combustible (burn-out) material into the filter shape, allowing it to dry, and then firing it to a ceramic state (approximately 900°C / 1652°F), firing out the burn-out material in the process. The flow rate of the fired filter is measured for quality control. In addition, silver is added as a bactericide. Although the manufacturing process is not complicated, a number of critical variables need to be controlled in order to ensure the quality of the final product. Production practices vary between factories, and while some factories in Nicaragua, Cambodia, and the Dominican Republic, for example, have ongoing research and quality control associated with their products, many do not.

As of 2007, PFP had started 17 filter factories of which eight were still producing filters (Lantagne 2006). In 2007-2008, another eight factories were built (PFP 2008). Currently, interest has been expressed in starting projects in 23 more locations. Given the large demand for filter factories, the current lack of standardized production methods, and the loss of knowledge in the filter community due to the recent passings of both Ron Rivera and Mickey Sampson, it is imperative that we summarize existing knowledge, establish production and quality control guidelines, and quantify how production variables affect the efficacy of the filter in order to responsibly increase filter production worldwide.

Thus, the goal of this working group panel of experts is to: “Provide guidance to assist filter factories in producing the most effective ceramic filters possible at the lowest cost.” The specific objectives are to: 1) summarize the existing knowledge on ceramic filter production and effects of production variables; 2) identify lessons learned from existing filter factories; 3) make recommendations on how to produce the most effective filters at the lowest cost; and, 4) identify areas where future research is needed (Annex A).

This report forms the deliverable from the working group and includes:

- 1) A literature review on ceramic filters (Chapter 2);
- 2) Results from a survey of production processes at existing filter factories (Chapter 3);
- 3) Chapters on filter production theory and recommendations, including materials sourcing and processing (Chapter 4), filter production (Chapter 5), kilns and firing (Chapter 6), silver (Chapter 7), quality control (Chapter 8), and packaging (Chapter 9);
- 4) A summary of lessons learned, recommendations for best practice, and suggestions for future research (Chapter 10);
- 5) Cross-cutting themes considered throughout this report include: cost, health and safety, environmental impact, breakage, microbiological efficacy, and end-user considerations.

The intention of this report is not to teach how to manufacture ceramic water filters, but rather, to assist existing filter factories to produce high quality ceramic filters and assist researchers in understanding the manufacturing process and where research is needed to better understand and improve upon ceramic filtration production processes and technology. We encourage anyone considering starting up a filter factory to contact an experienced filter consultant for assistance. Anyone considering carrying out research on ceramic filters is encouraged to contact members of the working group and share research proposals, summaries, and reports on line at [www.ceramicwaterfilter.org](http://www.ceramicwaterfilter.org). Questions can be directed to the working group members listed in the acknowledgements section of this document or to the forum at



[www.ceramicwaterfilter.org/forum/](http://www.ceramicwaterfilter.org/forum/). The website [www.ceramicwaterfilter.org](http://www.ceramicwaterfilter.org) is currently being updated to better suit the needs of the filter community.

## 2 Literature Review

Before discussing the production variables associated with ceramic filtration we would like to summarize the existing evidence-based research that establishes these ceramic water filters as an effective and appropriate HWTS intervention in developing countries. The following sections on treatment efficacy, social acceptability, and mechanisms for treatment were adapted from the literature review chapter of *Current Practices in Manufacturing of Ceramic Pot Filters for Water Treatment* (Rayner 2009).

### 2.1 Filter Efficacy

Diarrheal disease is caused by the ingestion of protozoan, bacterial, or viral organisms. Their sizes vary: typically protozoa are  $>4 \mu\text{m}$  in size, bacteria  $\sim 1 \mu\text{m}$ , and viruses are  $<1 \mu\text{m}$  in size. In the following sections, results from laboratory and field studies on the effectiveness of the filters at removing these organisms from drinking water, the association between diarrheal disease reduction and filter use, and the filter life span are presented. Please note that throughout these sections, contaminant reduction is reported as percent reduction or log reduction value (LRV), depending on how the data was reported by the researchers. Percent reduction and LRV equivalents are presented in Table 1.

Table 1: Log Reduction Value

LRV	Reduction
0.5	68%
1	90%
2	99%
3	99.9%

The quality of filtered water is categorized according to the risk level classification system (WHO 1997: 78) presented in Table 2.

Table 2: Water Quality Risk Levels

Number of Thermotolerant (fecal) coliforms or <i>E. coli</i> per 100 mL water sample	
<1	Conforms to WHO guidelines
1-10	Low Risk
10-100	Intermediate Risk
100-1000	High Risk
1000+	Very High Risk

#### 2.1.1 Protozoa Removal Effectiveness

Filters have been found to be effective against protozoa, which is to be expected because of the large size of protozoan organisms and oocysts. Protozoa, such as *Giardia lamblia* and *Cryptosporidium parvum*, exist in the environment as cysts and oocysts respectively and are

relatively large in size (>4 µm). *Cryptosporidium parvum* is resistant to chlorination. A Nicaraguan filter challenged with water spiked with *Cryptosporidium parvum* and *Giardia lamblia* achieved a 4-log reduction for both protozoa (Lantagne 2001a). Filters from Nicaragua, Ghana, and Cambodia achieved 2-6 LRVs when tested over a 12-week period for sulfite reducing *Clostridium* spore (1 x 1.5 µm) removal, an indicator for protozoan oocysts. The Nicaraguan filters performed slightly better than the Ghanaian and Cambodian filters and were found to be equally effective with or without colloidal silver application (van Halem 2006).

### 2.1.2 Bacteria Removal Effectiveness

Results of field studies carried out in several countries have found ceramic pot filters to be effective at improving the bacteriological quality of drinking water (Table 3). A study carried out in three regions of Guatemala reported that 91% of filtered water tested was free of fecal coliforms (AFA 1995). In Nicaragua, water quality analysis was performed on 24 filters in seven communities (Lantagne 2001b). Of 15 homes with *E. coli* in their source drinking water, eight (53%) tested negative for *E. coli* after filtration. In Cambodia, tests carried out after 1,000 ceramic filters were distributed showed that after up to 1 year in use, 99% of the filters produced water in the low-risk range of fewer than 10 colony forming units (CFU) of *E. coli* per 100 mL (Roberts 2004). Source water quality did not seem to affect filter efficacy. Another field study in Cambodia, with 80 filter and 80 control households, found that filtered water samples from households with filters reduced *E. coli* by a mean of 95.1% and as much as 99.99%. Sixty-six percent of filtered water samples conformed to World Health Organization (WHO) low risk classification and 40% of these conformed to WHO guidelines for safe drinking water. Whereas 62% of control households had *E. coli* levels that were high risk, only 14% of households with filters were measured at high risk. Filters in this study had been in use for up to 4 years (Brown *et al.* 2007). Another field study in Cambodia (Brown *et al.* 2008), with 120 filter and 60 control households, found that filters reduced *E. coli* by a mean of 96%, with 60% of filtered water samples meeting the low-risk range of fewer than 10 CFU of *E. coli* per 100 mL. In comparison, 85% of control households had more than 100 CFU per 100mL in their drinking water, which is classified as high-risk. In Ghana, household surveys and water quality analyses were carried out in over 40 households in 2006 and 2007 (Johnson *et al.* 2008), over half of which were filter users. Filters in Ghana reduced *E. coli* by 99.7% in traditional households and 85% in modern households. The average *E. coli* count was less than 10 CFU per 100 mL, falling within the low-risk range. A summary of field studies is presented in Table 3.

Several field studies have found a higher concentration of *E. coli* in filtered water than unfiltered water. In Nicaragua, seven of 24 homes (29.2%) with filters had higher levels of total coliforms (TC) in filtered water than in unfiltered water and some had higher levels of *E. coli* (Lantagne 2001b). In Cambodia, 5% of filtered water tested had a greater concentration of *E. coli* than stored water (Brown *et al.* 2008). In another study in Cambodia, 46 of 79 filters (58%) had a negative LRV (indicating an increase in contamination). Of the 58% with negative LRVs, 11% had negative LRVs on multiple visits (Brown *et al.* 2007). To explain these results, researchers have postulated that the receptacle and/or filter element became contaminated during cleaning. The evidence supporting this theory includes: 1) the commonly documented postcontamination of water at the household level (Wright *et al.* 2004); 2) the similar decline in water quality in both stored, boiled water and filtered water in Cambodian households; and, 3) that filter owners in Cambodia reported that potentially unclean cloths were used to clean

Table 3: Summary of Field Studies

Country	Number of Households		Indicator Tested	Filtered Water Quality			Time in use
	Filters	Control		% Reduction	LRV	% of filters & risk level <sup>a</sup>	
Guatemala (AFA 1995)	343 <sup>b</sup>	337 <sup>c</sup>	TTC			91% of filtered water samples conformed to WHO guidelines	Up to 1 year
Nicaragua (Lantagne 2001b)	24		<i>E. coli</i>			Samples from 53% (8) of 15 households with <i>E. coli</i> in source water conformed to WHO guidelines	6 to 18 months
Cambodia (Roberts 2003)	686		<i>E. coli</i>			98%-99% low risk	Up to 1 year
Cambodia (Brown <i>et al.</i> 2007)	80	80	<i>E. coli</i>	Mean 95.1% <sup>d</sup> ; up to >99.99%	Mean: 1.3-log	66% low risk; 40% conformed to WHO guidelines	Up to 2 or 4 years
			TC	90%	1-log		
Cambodia (Brown <i>et al.</i> 2008)	120	60	<i>E. coli</i>	Mean 96%	1.4-log	60% low risk; 39% conformed to WHO guidelines	18 weeks
Ghana (Johnson <i>et al.</i> 2008)	25 <sup>e</sup>	16	<i>E. coli</i>	99.7% (traditional); 85% (modern)		Average filter effluent low risk	Up to 1 year
			TC	99.4% (traditional); 90% (modern)			

a: No detectable TTC or *E. coli* per 100 mL sample: conforms to WHO drinking water quality guidelines; 1-10 Low risk; 10-100 Intermediate risk; 100-1000 High risk; >1000 Very high risk.  
b: Households with filters only and with both education and filters.  
c: Control households and education only; no filters.  
d: Water samples were not tested under challenge conditions; therefore, results potentially underestimate performance.  
e: Includes traditional and modern households.

filters and untreated water was used to clean the receptacle (Brown *et al.* 2007). Limitations to this theory are that stored water might not be from the same source as filtered water or that water could have been stored under conditions which improved its microbiological characteristics (Brown *et al.* 2007).

### **2.1.3 Virus Removal**

Virus removal remains a challenge for ceramic filters due to the small size of viruses and because silver has not been shown to inactivate viruses. In one study, water samples from filters with colloidal silver were less effective at removing the viral indicator MS2 bacteriophages; however, filters with or without colloidal silver were not found to be effective at removing MS2 bacteriophages (van Halem 2006).

The addition of goethite may promote increased sorption and inactivation of viruses as an 8-log reduction in surrogate viruses was measured in batch adsorption tests of ceramic material with goethite fired into it (Brown and Sobsey 2009). Resource Development International—Cambodia (RDI-C) adds laterite, which is rich in goethite and other iron oxides, to their filter mixture (Hagan *et al.* 2009) and although a 1-2 LRV (90%-99%) in MS2 was measured, no significant difference was found between filters with or without laterite (Brown 2007). Likewise, in a recent study (Bloem *et al.* 2009), filters manufactured with increased laterite content (which also increased the flow rate) did not show improved viral removal efficiencies; the mean LRV was less than 0.5. Filters with increased laterite were also heavier and more porous which might increase breakage and affect user acceptability (Bloem *et al.* 2009).

### **2.1.4 Diarrheal Disease Reduction**

Field studies with households using locally made ceramic filters have reported significant reduction in diarrheal disease. In one study in Cambodia, filter users reported a 49% reduction in diarrhea as compared with nonfilter users (Brown *et al.* 2008) and in another study a 46% reduction was reported (Brown *et al.* 2007). In Guatemala, 50% fewer cases of diarrhea were reported in children under 5 years of age in filter-using households (AFA 1995), and in Ghana filter users in traditional households were 70% less likely to have diarrhea (Johnson *et al.* 2008).

### **2.1.5 Filter Life Span**

Filter producers and implementing organizations typically recommend replacing filter elements every 1-3 years, although these recommendations have not been based on research. A study carried out in Cambodia found that after nearly 1 year of use, although fewer filters removed all *E. coli*, filters still treated water to low-risk levels (Roberts 2004). In another study in Cambodia, a relationship between time in use and microbiological effectiveness was not established, suggesting that filters can remain effective for up to 4 years, and possibly longer (Brown *et al.* 2007). After 5 years of use, filters collected from households in Nicaragua and tested in a laboratory were successful at removing >99% of *E. coli* (Campbell 2005).

A recent study tested two filters that had been used in the field for approximately 4 years alongside four filters with limited laboratory use and found that although for the first batch of *E. coli*-spiked water ( $10^6$  CFU/mL) filters achieved a 3-4 LRV; however, the LRV decreased in both sets of filters with each spiked batch (Bielefeldt *et al.* 2009). In addition, after three batches of spiked water had been put through the filter, when filled with clean water, bacteria not only

resuspended in the filtering element, but also passed through the filter into the effluent water. This suggests that although filtered water can become recontaminated due to improper cleaning and user maintenance, a higher bacteria count in effluent water than influent water could also result from high concentrations of bacteria in previously filtered water. A reapplication of colloidal silver improved the filter efficacy, but for the 4-year-old field filters removal efficiency of *E. coli* was not sustained. This indicated that the colloidal silver did not adhere well to the ceramic after years of use (Bielefeldt *et al.* 2009). More investigation is required to determine if this could occur in field conditions.

### **2.1.6 Arsenic**

Prolonged exposure to arsenic has been shown to cause cancer, and the most important route of exposure is through food and beverage consumption (WHO 2006). The WHO provides a provisional guideline value of 0.01 mg/L for arsenic in drinking water because available information on risk levels and health effects is limited (WHO 2006: 306). Although arsenic has been detected in filtered water (van Halem 2006), it has been found to leach out relatively quickly to concentrations below the WHO provisional guideline value, indicating that the amount in filtered water does not pose a health risk (Tun 2009). However, the cumulative consumption of arsenic, including additional routes of exposure, should be taken into consideration. The source of the arsenic in filters is unknown. Guidelines for testing arsenic in filter effluent are provided in Section 8.3.6.2.

### **2.1.7 Summary**

Ceramic filters have shown to be effective in both field and laboratory settings at improving water quality. Although filtered water in the field does not always meet WHO drinking water quality guidelines of <1 *E. coli* per 100 mL sample, water quality is significantly improved, often to low-risk levels. Ceramic filters have been shown to be reliably effective at removing more than 99% of protozoan and 90%-99.99% of bacterial organisms from drinking water in households, but further research is needed to establish their effectiveness against viruses.

Recontamination of filtered water during maintenance, including cleaning the filter element and receptacle with untreated water, using multiuse cloths, and dispensing treated water through a contaminated tap, has been reported and is a possible explanation for why, in some cases, filtered water has higher bacteria concentrations than source water. PFP-style filters have been associated with a reduction in diarrheal disease in users and filters appear to work well after several years in use; however, there might be a decline in effectiveness with time.

## **2.2 Social Acceptability**

Regardless of the ability of any technology to improve water quality, in order to achieve the goal of health improvement, that technology must be accepted and used. Although there are many factors which can contribute to the acceptance or abandonment of any intervention, with ceramic filters, breakage and low flow rates are frequently reported reasons associated with disuse. In Nicaragua, the flow rate of filters in 14 of the 24 households was inadequate to provide sufficient drinking water for the family (Lantagne 2001b). The recommendation to scrub filters to regenerate the flow rate (Lantagne 2001b) has since been incorporated into general operation and maintenance (O & M) instructions. In a Cambodian field study where filters were distributed for free, 20% of the households surveyed one year after implementation were no

longer using their filter. Of 35 households that reported not using their filter anymore, 71% stopped using their filter because the tap broke and 20% stopped using it because the filter element broke (Roberts 2004). Since replacements were not available, users did not have the option of replacing their filters. Other reasons reported for discontinued use included preferring boiled water, too busy or unwilling to clean the filter, the belief that their water does not need to be treated, and that the filter did not treat enough water (Roberts 2004). Interestingly, more than one-third of the households reported having enough water for additional uses besides drinking.

Similarly, another Cambodian field study (Brown and Sobsey 2006) documented a 2% per month disuse rate. Sixty-five percent of disuse was due to breakage of the element, receptacle, or tap. An additional 5% stopped using the filter because the filtration rate was too slow and did not meet the family's drinking water needs. Five percent stopped using the filter because it had exceeded its 1-year recommended useful life. Continued use was negatively associated with time since implementation—fewer filters were being used over time. A positive association was observed between continued filter use and user financial investment in the filter, surface water as a water source (people using ground water from deep wells were less likely to continue using the filters), access to sanitation, and a greater awareness of safe hygiene and sanitation practices (Brown and Sobsey 2006).

High user compliance is suggested by a field study in Cambodia where 100% of the respondents reported they used filtered water for all of their drinking water needs (Brown *et al.* 2008). In another field study in Cambodia, 95% of users reported satisfaction with the filters—that filtered water tasted good, that the filter was easy to maintain, that it was important to the family because of health benefits, and that it eliminated the need to boil water (Roberts 2004). In Ghana (Johnson *et al.* 2008), users reported that filters worked well, were easy to use, and they would recommend them to others. In addition, nonusers were interested in using filters. Follow up with 1,000 households 6-12 months after they received filters postflooding in Ghana, found that 63% of the filters were still in use. Of the 13% who stopped using the filter due to breakage, 95% was due to breakage of the ceramic filtering element and 5% was due to breakage of the safe storage container or the tap. Twenty-four percent (24%) stopped using the filter because their access to rainwater or an improved water source resumed postemergency (Desmyter *et al.* 2009).

### **2.2.1 Summary**

Overall, it is clear there is high user acceptability of the filter and potential for long-term use, although breakage over time and the inability to filter sufficient water remain concerns with PFP-style ceramic water filters.

## **2.3 Mechanisms of Effectiveness**

Mechanisms that contribute towards the efficacy of the filter are discussed in the following sections: 1) bacterial deactivation by silver; 2) pore size and porosity; and, 3) hydraulic properties and flow rate (the indicator that is measured locally).

### 2.3.1 Silver

Filter elements are either brushed with or dipped in a colloidal silver solution, or colloidal silver is included in the filter mixture and fired into the filters. Some factories brush a silver nitrate solution on filters instead of colloidal silver.

Investigations into the effectiveness of different colloidal silver application methods have found that colloidal silver should be applied to both the inside and outside of the filter for increased microbiological reduction (Lantagne 2001a). Although it has been recommended that filters be dipped rather than brushed with colloidal silver to ensure the full path of water flow through the filter is coated (Fahlin 2003), it has since been concluded that the quantity of colloidal silver applied is more important than the application method (Oyanedel-Craver and Smith 2008). It is unknown how deeply silver penetrates into the filter walls; however, a recent study found that after dipping, some silver segregates to the surface of the ceramic during drying (Larimer *et al.* 2010). It has been theorized that silver could reduce total pore area and adsorptive surface area (van Halem 2006), but tracer experiments on filters postcolloidal silver application did not suggest this (Oyanedel-Craver and Smith 2008).

The amount of silver measured in filtered water is below USEPA and WHO guideline values for silver (0.1mg/L), and therefore does not pose a risk to human health (Lantagne 2001b; Lantagne 2001a). Other studies have also found that the amount of silver in the effluent water does not exceed WHO guidelines (Oyanedel-Craver and Smith 2008) and that silver contributes to the microbiological removal effectiveness (van Halem 2006; Oyanedel-Craver and Smith 2008). In addition, it has been observed that the silver inhibits biological growth from forming on the filters and in the receptacles (Oyanedel-Craver and Smith 2008; Bloem *et al.* 2009). It has been concluded that the mechanism by which silver improves filter performance is by disinfection (Oyanedel-Craver and Smith 2008). Filters produced with colloidal silver fired into the filters have also been found to be effective at removing *E. coli* and TC (Lantagne *et al.* 2009).

Some factories use silver nitrate because it is less expensive than colloidal silver. Although filters manufactured with a high flow rate showed improved microbiological efficacy after silver nitrate application (Bloem *et al.* 2009), in the field, the microbiological efficacy of filters brushed with silver nitrate was found to be comparable to filters with no silver applied (Brown 2007). For more information on silver, please see Chapter 7.

### 2.3.2 Pore Size and Porosity

The pores in the filter act as a physical barrier to pathogens, other organic material, and turbidity in the influent water. During firing the burn-out material in the filter mixture fires out, thus increasing the porosity of the filter. Pore size is assumed to be determined by the particle size and the amount of burn-out material added to the clay (Lantagne 2001a), but pore size has also been linked to the clay content (Oyanedel-Craver and Smith 2008).

Pores in the lip of a filter from Nicaragua, where sawdust is used as a burn-out material, were measured using a scanning electron microscope and were found to range from 0.6  $\mu\text{m}$  to approximately 3  $\mu\text{m}$  in size (Lantagne 2001a). There were also cracks and spaces measuring up to 150  $\mu\text{m}$  and 500  $\mu\text{m}$  respectively, which could be of concern if interconnected; however, this would also likely increase the flow rate beyond the acceptable limit (Lantagne 2001a). In



theory, the lip of the filter receives the least amount of pressure; therefore, the size of the cracks and spaces were assumed to be the worst case scenario. A later study, using mercury intrusion porosimetry, found that the pore size distribution and porosity did not vary significantly from the bottom, middle, and lip sections of the filter (van Halem 2006). The total pore area, which might contribute to increased adsorptive capabilities, has been found to vary widely within a given filter (van Halem 2006).

Filters manufactured in different countries have been found to vary both in porosity and pore size. Mercury intrusion porosimetry measurements of filters from Cambodia showed a porosity of 43%, while filters from Ghana showed a porosity of 39%, and filters from Nicaragua showed a porosity of 37% (van Halem 2006). Pore sizes were measured as follows: Cambodia 25  $\mu\text{m}$ , Ghana 22  $\mu\text{m}$ , and Nicaragua 17  $\mu\text{m}$  (van Halem 2006). The manufacturing details for the filters used in this study were not available so it is not possible to compare findings with manufacturing methods.

Filters with effective pore size diameters ranging from 33-52  $\mu\text{m}$  (mean 40  $\mu\text{m}$ ) were successful at removing micro-organisms smaller than the pores; therefore, it was suggested that filters work by additional mechanisms to mechanical screening, including sedimentation, diffusion, inertia, turbulence, and adsorption (van Halem 2006). In addition, high tortuosity, which influences the distance water must travel to exit the filter walls, increases total surface area and can encourage these processes (van Halem 2006). A comparison (based on the mercury intrusion porosimetry and the Kozeny constant) of the tortuosity of filters from Cambodia, Ghana, and Nicaragua found that the filter material from Nicaragua is more tortuous (van Halem 2006). Since tortuosity reflects the actual path the water takes through the filter, it can influence the various mechanisms at work. This was supported by evidence of higher removal of *Clostridium* spores and *E. coli* by the Nicaraguan filters (van Halem 2006).

Although these additional mechanisms contribute towards the effectiveness of filters at removing microbiological contamination, a correlation between pore size and bacteria removal has been found; therefore, mechanical screening by size exclusion is significant: filters with smaller pores have a higher removal rate of bacteria (Oyanedel-Craver and Smith 2008). A correlation has been found between clay content (particle size <2  $\mu\text{m}$ ), pore size, and flow rate. Although the porosity (the volume of void space in the filter) was found to be the same when comparing model filters made from different clays, the median pore diameter differed, correlating with the clay content. This study concluded that clay with “relatively uniform and fine-grained particle-size distributions will likely produce filters with better bacteria-removal efficiency, smaller pores, and lower dispersion than comparatively coarse-grained, heterogeneous soils” (Oyanedel-Craver and Smith 2008: 931). The predominant mineral in the clay might also influence both the hydraulic conductivity (the rate water moves through the filter) and the porosity. The filter model that measured highest in these aspects was made from clay with a high kaolinite (a clay mineral) content (Oyanedel-Craver and Smith 2008).

### **2.3.3 Hydraulic Properties and Flow Rate**

The rate water travels through the walls of the filter will affect the filtration mechanisms and the amount of contact time with colloidal silver. Investigations into the hydraulic properties of the filters have been inconclusive (Fahlin 2003). However, using a bromide tracer breakthrough test, it was estimated that water remains in the pores of filters for 50 minutes which, depending

on the thickness of the silver layer, should provide sufficient contact time with silver to deactivate bacteria (Fahlin 2003). Whereas Fahlin (2003) investigated the flow through flat bottomed filters, Miller (2010) modeled and verified flow through a parabolic-shaped (oblong) filter (Figure 3-9). Hydraulic conductivity was determined to be consistent throughout the height of the parabolic filter.

The flow rate of a filter is the amount of water that passes through a full, saturated filter in the first hour. Measured locally, it is used as an indicator of: 1) production consistency; 2) the presence of cracks, holes, or large pores; and, 3) potential contact time with silver. It is also an important practical consideration, as filters need to treat enough water daily for a family at a rate that is convenient for an appropriate pattern of use.

Considerable reduction in flow rates due to clogging have been noted in laboratory (Lantagne 2001a; Fahlin 2003; van Halem 2006) and field studies (Lantagne 2001b). Although scrubbing has been shown to temporarily increase the flow rate (Lantagne 2001b), in the laboratory, filters did not return to their original flow rate after scrubbing and flow rates continued to decrease over time to less than 0.5 L/hr, which is insufficient to meet a family's drinking water needs (van Halem 2006). Fahlin (2003) found that clogging impeded his research into the hydraulic conductivity of filters. However, in some field investigations users have reported that filters provided enough water for additional uses (Roberts 2004) and only 5% of filter disuse was attributed to reduced flow rate (Brown and Sobsey 2006).

In a study to see if flow rate could be increased without sacrificing the microbiological removal efficacy of filters, filters with flow rates of 8-10 L/hr were manufactured with either increased burn-out material (rice husk) or increased laterite (Bloem et al. 2009). During the 6-month study, no significant difference was measured in *E. coli* removal between the filters with higher flow rates and lower flow rates. The application of silver nitrate influenced *E. coli* removal; filters with silver nitrate achieved nearly twice the mean LRV of *E. coli*. This study concluded that although future research is necessary to investigate the long-term effects, initially, it appears that increasing the flow rate does not reduce the microbiological efficacy of filters (Bloem et al. 2009).

In another study, 6-liter capacity, oblong filters were manufactured with increased flow rates by altering the type or increasing the amount of burn-out material in the filter mixture. The results showed that beyond a flow rate of approximately 1.7 L/hr, consistent TC reduction began to drop below 99% (Klarman 2009). These filters were made at a factory that aims to leave a carbon core within the walls of the filter, which differs from the filters tested in other research. This could have influenced the results as it appeared to affect both the flow rates and the turbidity of the effluent water, the latter was considerably higher during the first week. The flow rates of several of the filters in this study actually doubled during the 5-week testing period (Klarman 2009).

At the RDI-C factory, in order to achieve the acceptable flow rate range, the filter mixture ratio is adjusted according to the size of the rice husks received; more rice husk is added if the particle size appears to be smaller (Hagan et al. 2009). This indicates a relationship between burn-out particle size and flow rate. However, no significant difference in flow rates were measured in filters manufactured using a larger mesh to sieve sawdust used in filter mixture (Klarman 2009). Filters manufactured with different burn-out materials (coffee husks and rice husks) using the

same ratio by volume and sifted to the same screen size as filters manufactured with sawdust, had faster flow rates and reduced TC removal efficiency. These findings emphasize the need to develop a new ratio when changing the burn-out type (Klarman 2009).

## **2.4 Summary**

There are contradictory findings and continuing debate regarding the relative importance of the various mechanisms of action on the effectiveness of the filter. Colloidal silver has been found to reliably increase the effectiveness of the filter, while silver nitrate results have not been consistent. Little is known about the hydraulic properties of the filter and pore size investigations have documented variation by country of manufacture. Flow rate is presently relied upon as an indicator of production consistency as it is easy and inexpensive to measure locally. Studies investigating the relationship between flow rate and microbiological removal efficiency have had contradictory findings (Bloem *et al.* 2009; Klarman 2009). Therefore, more research is recommended to better understand the mechanisms of effectiveness and the materials characteristics and manufacturing processes that influence them.

## 3 Overview of Filter Production: Survey Results

Information in this chapter is summarized from the report *Current Practices in Manufacturing of Ceramic Pot Filters for Water Treatment* (Rayner 2009), a research project carried out to identify the various filter factories worldwide and to survey and document existing production practices at each facility. A summary of the results from this survey is presented in the following sections. An overview of the production process is presented in a filter production flow chart at the end of this chapter (Figure 3-14).

### 3.1 Survey Development and Limitations

To complete this research, a mind map (Figure 3-1) was developed outlining the variables in ceramic water filter production, including known variations in the manufacturing process evident from the comparison of several filter production manuals. A questionnaire was developed consisting of quantitative and qualitative questions formulated to address each of the variables identified in the mind map. Quantitative questions addressed typical manufacturing procedures and qualitative questions encouraged participants to comment on each phase of production, including identifying challenges and successes they have experienced or aspects of production not included in the questionnaire.

Production facilities were identified and contact information for the various filter factories was gathered from representatives of PFP, Potters without Borders, FilterPure, and members of the Ceramics Manufacturing Working Group. The selection criterion for survey participation was that factories must be currently producing filters on a full-time, part-time, or per-order basis. All filter factories meeting the criterion were sent an invitation by e-mail (in English and Spanish) and those who expressed interest were e-mailed the questionnaire with a request to schedule an interview. Participants completed a questionnaire, a phone interview, or both.

Before presenting the results, we would like to note that the limitations of the survey methodology included: 1) self-selection bias which may have influenced who responded to the invitation; 2) “social desirability” responding, whereby answers may have been biased to show the respondent in a desirable light (Sapsford and Jupp 1996); 3) interviewer bias, in which prompting by the interviewer may have introduced bias in the respondents’ answers (Sapsford and Jupp 1996); 4) the length of the questionnaire (10 pages) may have discouraged detailed responses, particularly for questions towards the end; and, 5) variable knowledge and level of familiarity with the production process among respondents may have influenced the accuracy of answers and the level of detail provided.

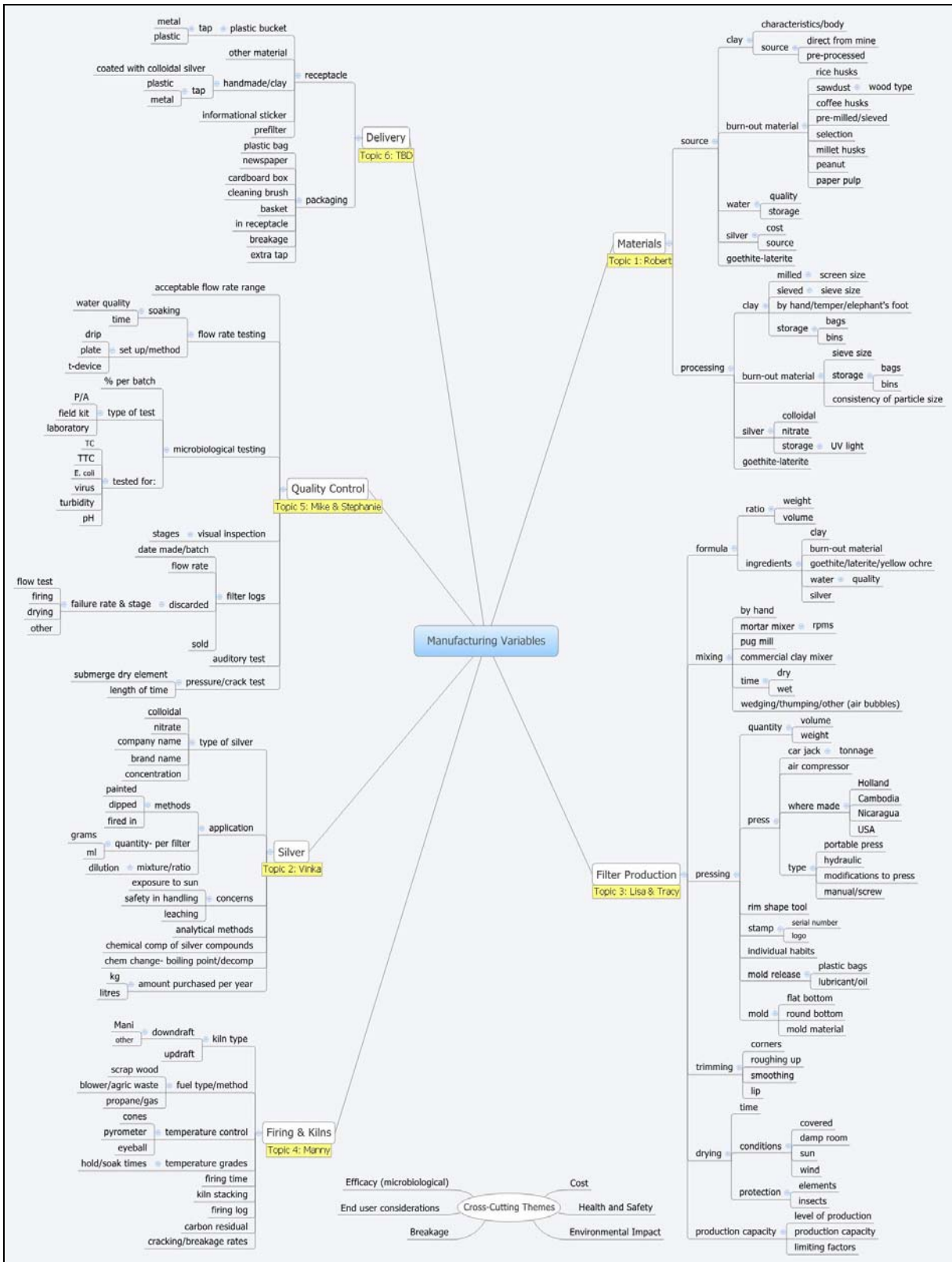

Figure 3-1: Production Variables



Table 4: Participating Factories

<b>Code</b>	<b>Country</b>	<b>Organization</b>	<b>Year Started</b>	<b>Production</b>
Benin	Benin	Potters without Borders	2007	Part Time
Cam-1	Cambodia-IDE	Potters for Peace	2001	Full Time
Cam-2	Cambodia-RDI	RDI-C	2003	Full Time
Colombia	Colombia	Potters for Peace	2007	Full Time
DR	Dominican Republic	Filter Pure	2006	Part Time
Guate-1	Guatemala- Antigua	AFA Guatemala	2004	Full Time
Guate-2	Guatemala- San Mateo	Potters for Peace	2005	Part Time
Indo-1	Indonesia- Bali	Potters for Peace	2007	On Order
Indo-2	Indonesia- Bandung	RDI-C & Potters for Peace	2005	Full Time
MM-1	Myanmar- Twante	Thirst-Aid	2008	Full Time
MM-2	Myanmar- Twante	Thirst-Aid	2007	Full Time
MM-3	Myanmar- Twante	Thirst-Aid	2009	Full Time
MM-4	Myanmar- Twante	Thirst-Aid	2009	Full Time
MM-5	Myanmar-Yangon	Thirst-Aid	2008	Full Time
MM-6	Myanmar- Pathein	Thirst-Aid	2008	Full Time
MM-7	Myanmar- Yangon	Thirst-Aid	2006	Full Time
MM-8	Myanmar- Sagaing	Thirst-Aid	2009	Part Time
Nica-1	Nicaragua- San Marcos	Potters for Peace	1998	Full Time
Nica-2	Nicaragua- Ciudad Sandino	Potters for Peace	unknown	Part Time
Nigeria	Nigeria	Potters for Peace	2008	Full Time
SL-1	Sri Lanka- Kelanya	Potters for Peace	2007	Full Time
SL-2	Sri Lanka- Matara	American Red Cross	2008	Full Time
Tanz-1	Tanzania- Arusha	Filter Pure	2009	Full Time
Tanz-2	Tanzania- Tabora	Potters for Peace	2007	On Order
Yemen	Yemen	Potters without Borders	2008	Full Time

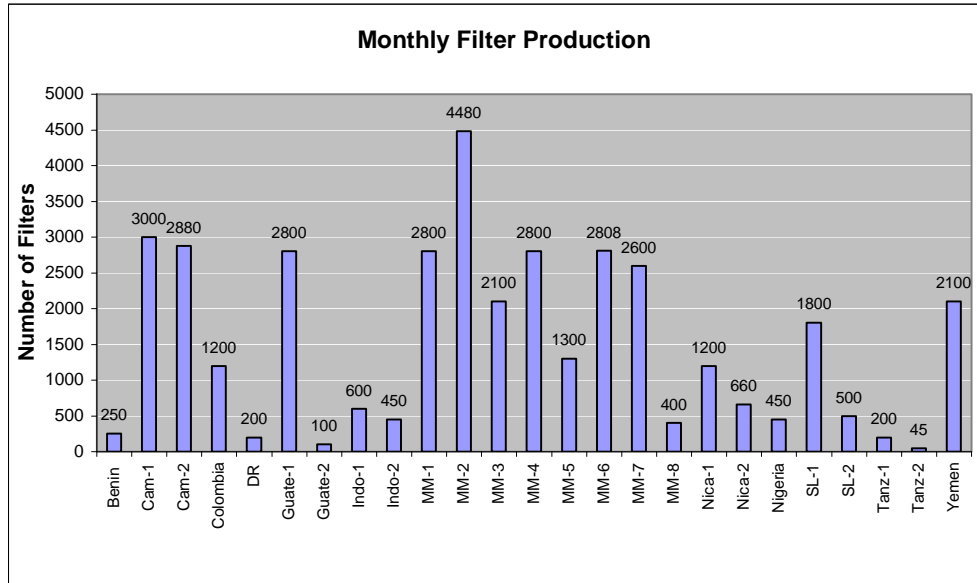

Figure 3-3: Monthly Filter Production

The average wholesale price of a complete filter unit is US\$15.71 and ranges from US\$7.50-\$35.00 ( $n=24$ ). The average retail price is \$16.68 ( $n=23$ ), ranging from US\$8.00-\$35.00. The replacement cost for just the ceramic filter element averages US\$7.78 wholesale and ranges from US\$3.00-\$25.00; for retail, they average US\$8.60 and range from US\$4.00-\$25.00 (Figure 3-4).

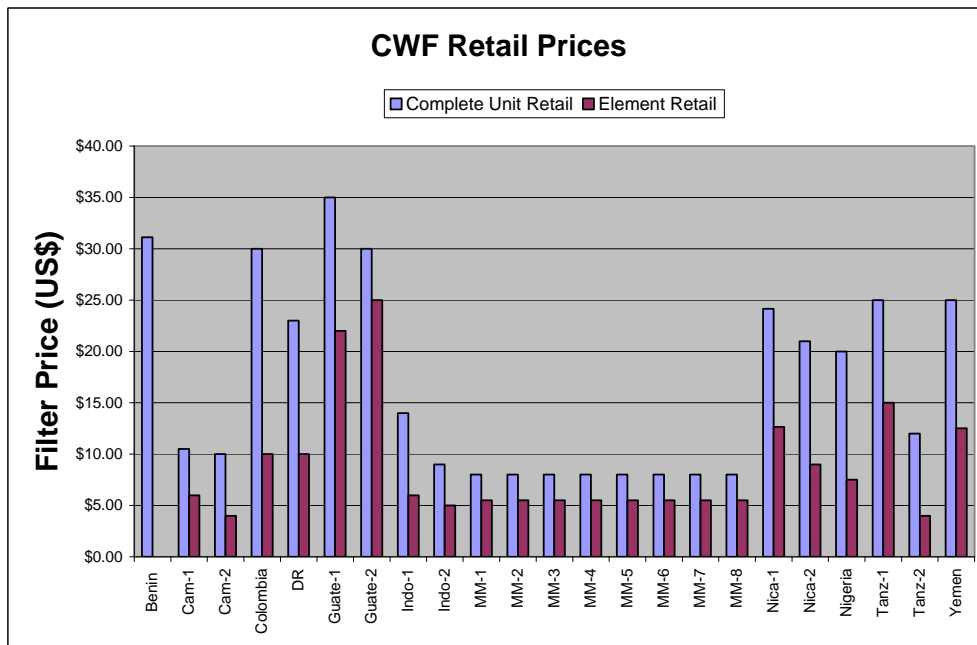

Figure 3-4: CWF Retail Prices

Fifteen factories ( $n=24$ , 62%) sell more than 50% of their filters to NGOs or international nongovernmental organizations (INGOs). Six factories (25%) sell 50%-100% of their filters to the public. Cam-2 sells about 50% to the public and 50% to NGOs. One factory (MM-8) sells



90% of their filters to the government. Filters manufactured at SL-2 are sold exclusively to the Sri Lankan Red Cross.

### **3.2.1 Factory Resources**

Eight factories ( $n=24$ , 33%) receive 100% of their electrical supply from the grid. Six factories (25%) rely upon a generator (Cam-2, MM-1, MM-2, MM-3, MM-4, and MM-6), and seven (30%) rely upon both the grid and a generator for their power supply. Three (13%) do not use electricity in production (Indo-2, Guate-1, and Yemen). Nine factories do not have electric mixers ( $n=25$ ), two do not have hammermills, and few have air compressors.

Water is used for filter production and flow rate testing. Factories ( $n=18$ ) rely upon 24-hr piped municipal supply (8, 44%), intermittent supply (1, 6%), water being trucked in (2, 12%), alternative sources including ground or rainwater (3, 17%), or a combination of sources (4, 22%). Fourteen factories ( $n=18$ , 78%) consider their water supply reliable. Eight factories ( $n=18$ , 44%) have not tested their source water.

## **3.3 Materials**

### **3.3.1 Clay**

Clay plays an important role in filter quality. Although at least five factories ( $n=17$ , 30%) mentioned having identified reliable clay sources, both the Yemen and Colombia factories mentioned the challenges and effects of inconsistent clay quality on filter production. Clay sources ( $n=17$ ) are those typically used by local potters (6, 35%) and are selected based on quality (6, 35%), plasticity (5, 30%), proximity of the mine (4, 24%), and color (1, 6%).

Seventeen factories ( $n=18$ , 94%) receive their clay directly from the mine and process it themselves, while Cam-2 receives their clay preformed into bricks. Two factories (Benin and SL-2, 11%) prepare a clay body by blending three clays. Clay is milled and sieved to remove impurities, such as sand and organic material. Sixteen factories mill their clay ( $n=17$ , 94%) and 15 factories ( $n=18$ , 83%) sieve their clay using between 9 and 80 mesh (equivalent to 2 mm-0.18 mm openings, see Tyler Mesh Equivalent chart Annex B) (Figure 3-5). The mesh size used might depend upon the availability of sieves in each country.

### **3.3.2 Burn-out Material**

Factories reported using sawdust, rice husks, and peanut shells as burn-out material. Ten factories ( $n=18$ , 56%) use sawdust from woods including pine, guanacaste, gravella, oak, mixed woods, or the type of wood may depend upon availability. Of the remaining eight factories, seven (39%) use rice husks and one (6%) uses a mixture of sawdust and peanut shells as the burn-out material. MM-all reported that variation in rice husk quality affects the outcome of the filters and the DR factory reported that oak sawdust leaves an oily residue on fired filters and results in a reduced flow rate.

Although 15 factories ( $n=17$ , 88%) sieve their burn-out material, only 12 (80%) indicated the mesh size (Figure 3-6). Although the 60 and 80 mesh sizes (0.25 and 0.18 mm openings respectively) reported by two participants could be mistakes, even if eliminated from the results, the remaining mesh sizes used range from 8 to 48 mesh (2.38 mm to 0.30 mm openings). At

Indo-2 and MM-all, burn-out material is sieved with two different sized screens to exclude both the finer and larger particles.

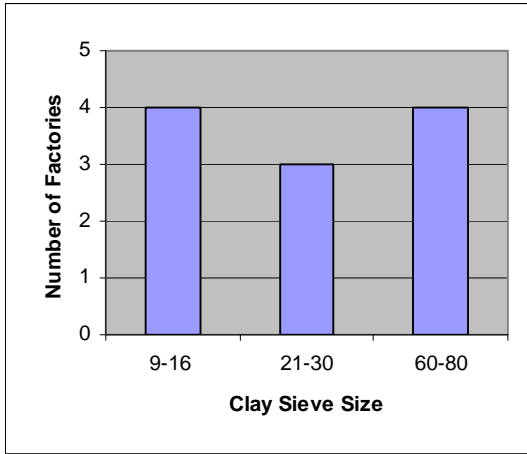

Figure 3-5: Clay Sieve Sizes

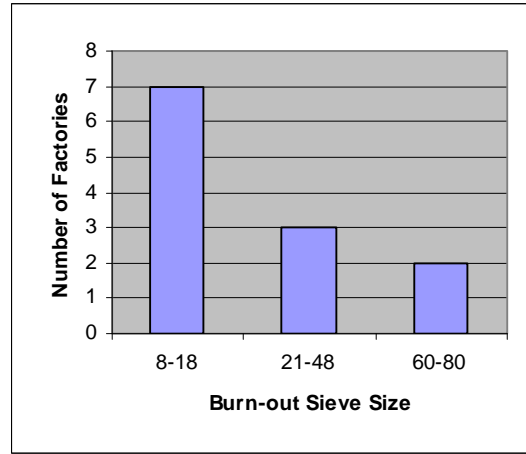

Figure 3-6: Burn-out Sieve Sizes

### 3.4 Additional Materials

Two factories, DR and Tanz-1 (n=18, 11%), add colloidal silver diluted in water to their dry filter mixture. Cam-2 adds laterite, a mineral thought to provide additional viral binding sites. Others regularly include grog (ground up, fired clay) (Indo-2), or sand (Guate-1). Guate-2 sometimes adds grog from bricks that did not fire well, though they did not indicate why or when. SL-2 found that the addition of grog reduced shrinkage of the fired filter elements to the point that the filter elements would not fit in the receptacles.

### 3.5 Ratio and Mixing

Clay and burn-out material are measured by either weight or volume. Where rice husks are used (n=7), materials are measured by weight (n=6, 100%) and the percentage of rice husks added to the mixture ranges from 10 to 24% (Figure 3-7).

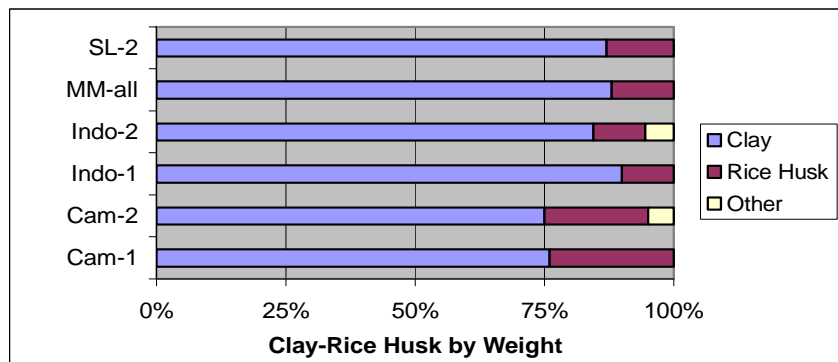

Figure 3-7: Clay-Rice Husk Ratio

Where sawdust is used (n=10), 60% of the factories measure by weight and 40% measure by volume. The percentage of sawdust ranges from 5%-25% by weight (Figure 3-8) or 47%-50% by volume. Where both sawdust and peanut shells are used (n=1), ingredients were reported to be measured by both weight and volume, and the burn-out material consists of 35% of the mixture.

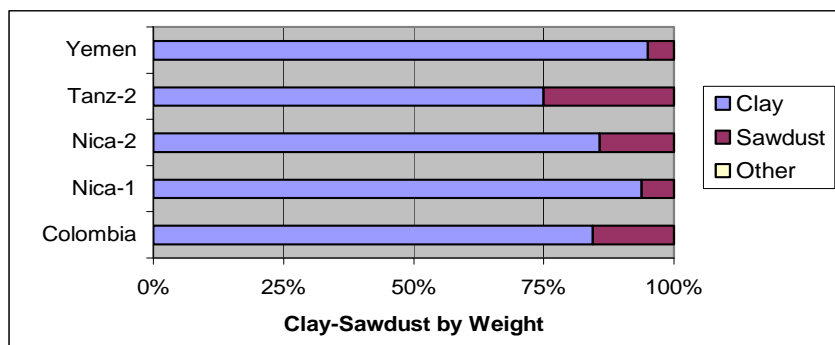

Figure 3-8: Clay-Sawdust Ratio

Once a filter mixture formula has been established, adherence to the formula varies at most factories. Of the surveyed factories, three factories (n=16, 19%) do not adjust their formula, one factory (6%) adjusts it regularly, and 12 factories (75%) adjust it as needed. Five of the factories surveyed (31%) modify their formula depending on the quality of the clay. Other reasons for adjusting the ratio included variation in the particle size of the burn-out, burn-out material characteristics, weather conditions, and/or flow rate.

The amount of time clay and burn-out material are mixed for varies from 5 to 20 minutes for dry materials, with the exceptions of Indo-2, where dry ingredients are hand mixed for 60 minutes in order to achieve specified flow rates, and Nigeria, where the mixing process takes half a day. Wet mixing time ranges from 5 to 30 minutes. At Nica-1, because of the type of mixer, dry ingredients are not mixed in advance of adding water; all materials are mixed together for 45 minutes.

Fifteen of the surveyed factories (n=18, 83%) wedge, knead, or thrust the mixture before pressing. Nine factories (n=15, 60%) always press filters the same day the mixture is prepared and six factories (40%) sometimes or normally leave the mixture overnight. Ten factories (n=15, 67%) do not reprocess greenware (not yet fired) filters that do not pass quality control into new filters, whereas six factories (n=15, 40%) reprocess greenware to make new filters (DR, Nica-2, SL-2, Tanz-1, Yemen, and Tanz-2). Of these, four factories remill the dried filter mixture before they rehydrate it (Nica-2, SL-2, Tanz-1, and Tanz-2).

### 3.6 Forming Filter Elements

All factories press their filters using a mechanised press and a mold, although in Rabinal, Guatemala, filters are still made on the potter's wheel and sold through Guate-1. Press designs vary between factories (Figure 5-3, Figure 5-4, Figure 5-5, and Figure 5-6).

Molds (n=25), vary in size and design and are made out of aluminum, cast iron, cement, steel, or carved from teak wood. There are three filter shapes (Figure 3-9): the original flat-bottomed design is produced at 15 factories (60%), a slightly parabolic semispherical filter is produced at eight Thirst-Aid factories (32%), and an oblong, round-bottomed filter is produced at two FilterPure factories (8%). Filter capacity ranges from 6-11 L with depths ranging from 22.5 to 29 cm. Wall thickness ranges from one to three centimeters. Filter dimensions at the various factories are presented in Annex C.

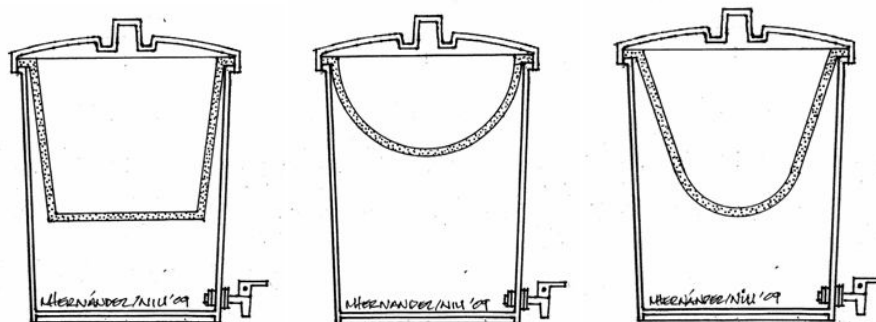

Potters for Peace  
(7-11 liters)

Thirst-Aid  
(10 liters)

FilterPure  
(6 liters)

Figure 3-9: Filter Shapes

(Hernandez 2009)

All filter factories (n=17, 100%) expressed satisfaction with their method of releasing the pressed filter from the mold. Thirteen factories (n=13, 72%) use plastic bags, the factories in Myanmar brush vegetable oil on plastic bags, and four factories (23%) apply either coconut or palm oil to the mold as a mold release.

### 3.7 Stamping, Surface Finishing, and Drying

All factories (n=18, 100%) stamp their filters with a batch and serial number and eight factories (n=16, 50%) also stamp them with a logo. All but SL-1 and Tanz-2 (n=18, 89%) touch up or trim filters to fix irregularities after pressing. However, six factories (SL-2, Benin, Yemen, MM-all, Guate-2, and Tanz-1) only touch up the lip of the filters and do not touch the inside or outside of the filter.

Drying time (n=18) varies depending on the weather and is a challenge for at least eight factories (44%). Some factories have modified their production pattern or increased shelving to allow for longer storage during the wet season, others have introduced quick drying methods. Drying times (n=24) average seven days in the dry season (min 3, max 21) and 13 days in the wet season (min. 4, max. 45) (Figure 3-10).

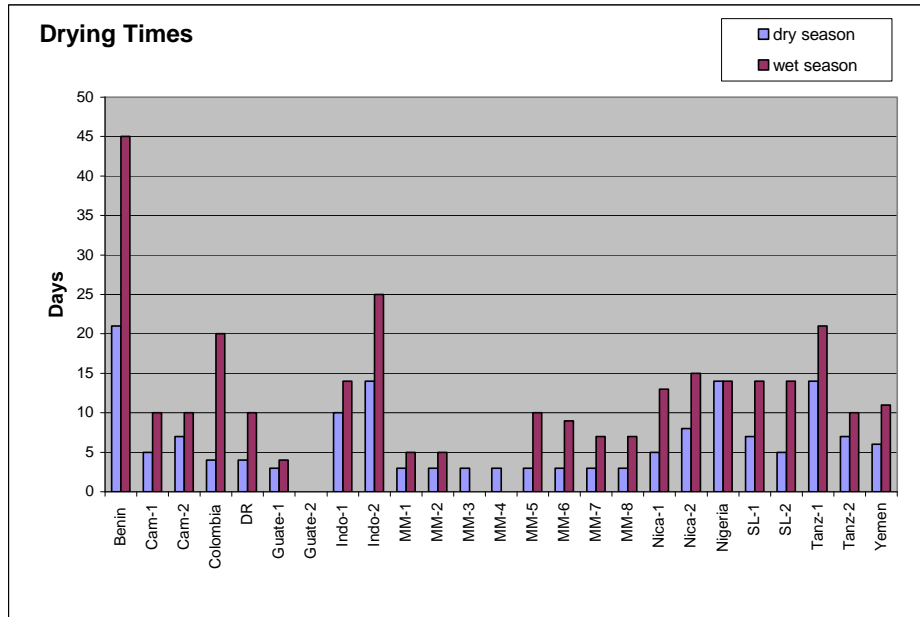

Figure 3-10: Drying Times

### 3.8 Firing

Five factories (28%) mentioned that production is limited by the number of kilns and the time it takes to fire and cool the kilns. Firing time ranges from 6-14 hours and cooling takes 12-24 hours. Factories (n=18) have between one and seven kilns with capacities ranging from 40 to 200 filters. Nine factories (n=17, 53%) have Mani Flat Top or Mani Arch kilns (see Section 6.2 for a description of kiln types). Fifteen factories (n=18, 83%) fire with wood, Tanz-1 fires to 600°C with wood then propane for the last 2 hours, the Yemen factory fires with propane, and the Benin factory fires with oil.

Target temperature ranges from 700°C to 980°C. All factories (n=18, 100%) use either a pyrometer (9, 50%) or cones (5, 28%) to monitor temperature and four factories (22%) use both. Although six factories (33%) report estimating temperature visually they all use at least one other method (Annex C). Of the nine factories that use cones (n=9), only one (Nica-1) factory uses the three cone method (Section 6.5.2). Some factories reported difficulty acquiring pyrometers or cones in country (Indo-2, SL-2).

### 3.9 Silver

#### 3.9.1 Silver Type

Fifteen factories use colloidal silver (n=18, 83%), and three use silver nitrate (17%). MM-all have recently started transitioning towards using silver nitrate and apply either colloidal silver or silver nitrate to their filters. Tanz-2 does not use either, but rather sodium silver chloride tablets. Colloidal silver (n=15) is purchased in liquid (7, 47%) or powdered (10, 67%) form and Guate-2 and Benin use either. Silver nitrate is purchased in powdered form (n=3, 100%). None of the factories produce their own colloidal silver.

Silver is diluted (n=15) using water purified by reverse osmosis (1, 7%), groundwater (3, 20%), filtered groundwater (1, 7%), municipal water (3, 20%), municipal water without chlorine (1, 7%),

de-ionized water (2, 13%), distilled water (1, 7%), potable water (2, 13%), or untreated surface water (1, 7%). The factories that use silver nitrate, included in the above counts, use water purified by reverse osmosis (MM-all) and de-ionized water (Indo-2, Cam-2).

### 3.9.2 Silver Application Methods and Concentrations

A silver solution is applied (n=18) by dipping (6, 33%), brushing (10, 56%) or it is fired into the filters (2, 11%). Cam-1 does not apply silver to filter rims. Dilution information was provided by nine of the factories that use colloidal silver (n=16, 56%). The silver concentrations range from 14-1500 parts per million (ppm). Excluding the two extremes as possible errors, the silver concentration applied to filters ranges from 107 to 288 ppm. Table 5 details the dilution and concentration of *colloidal* silver when applied by brushing and Table 6, when applied by dipping.

Table 5: Colloidal Silver Applied by Brushing

Country	Silver from	Company	Form	Concentration (%)	PPM	Silver Solution (ml)	Water (ml)	Diluted Solution (ppm)	Silver in Filter (mg)
Cam-1	Spain	Argenol	Liquid	3.2	32000	1	300	107	32
SL-1	Spain	Argenol	Liquid	3.2	32000	2	300	213	64
SL-2	Spain	Argenol	Liquid	3.2	32000	2	300	213	64
Nica-1	Spain	Argenol	Powder	3.2*	32000	2	300	213	64*
MM-all	Germany	Reickerman-Spraylat	Liquid	3.2	32000	3	333	288	96

\*Reports using powdered silver, Argenol Labs only sells powdered silver to the filter factories in concentrations of between 70%-75%; therefore, it is likely Nica-1 prepares a silver concentrate, which is further diluted according to the above specifications.

Table 6: Colloidal Silver Applied by Dipping

Country	Silver from	Company	Form	Concentration (%)	PPM	Silver (grams)	water (ml)	Silver solution (ppm)
Benin	Spain	Argenol	Liquid/Powder	4	40000	14	40000	14*
Colombia	Spain	Argenol	Powder	75	750000	70	250000	210
Indo-1	Spain	Argenol	Powder	75	750000	20	1000**	1500
Yemen	Spain	Argenol	Powder	75	750000	14	40000	263

\*If silver is purchased from Argenol Labs in powder form as reported, then it is between 70%-75%. Using 75% silver would result in the diluted solution being 263 ppm. If these figures are for the 3.2% solution from Argenol Labs, then the diluted solution would contain 11 ppm.

\*\* This might be a typographical error. Confirmation was not possible.

Tanz-1 and DR fire a confidential amount of colloidal silver into their filters and brush colloidal silver onto fired filters. Tanz-2 dips filters in a solution made from dissolving five tablets of

Katadyn Micropur Forte, a sodium silver chloride complex with 0.1% silver ions and 2.5% sodium dichloroisocyanurate, in seven liters of water. The Myanmar factories, Indo-2, and Cam-2 brush a silver nitrate solution on each filter. Both Myanmar and Cam-2 prepare a concentrated solution which is further diluted at the factory before application. At Indo-2, 0.5 grams of silver nitrate (ppm unknown) is added to 400 ml of water and brushed onto each filter.

### **3.10 Quality Control**

#### **3.10.1 Visual and Auditory Inspections and Pressure Tests**

All factories (n=17, 100%) carry out visual inspections at various stages during production and one reports using a magnifying glass. Nine factories (53%) carry out four formal visual inspections including before firing, before flow rate testing, before applying silver, and before packaging. Four factories (24%) carry out visual inspections at just two stages and three factories (18%) carry out just one visual inspection before firing, before flow rate testing, or before packaging. Workers look for (n=16) cracks (15, 94%), deformity (9, 56%), defects or irregularities (8, 50%), and uniformity of color (3, 19%). Note, numbers add up to more than 100% due to multiple answers.

Auditory inspections (n=15), which can detect under- or overfiring or the presence of cracks, are always performed at seven factories (47%). At Cam-1, auditory inspections are performed on ten filters per month.

Pressure tests (Section 8.3.3) are performed always at the Benin, Cam-2, Indo-1, Nica-1, Nica-2, and MM-all factories (n=15, 40%) and sometimes at the DR and Nigeria factories (13%). Seven factories (47%) do not perform pressure tests on their filters.

#### **3.10.2 Flow Rate**

All filter factories but two perform flow rate tests on 100% of their filters (n=18, 89%). DR performs flow tests on 8% of their filters and Tanz-1 on 4%. Five factories (28%) soak their filters for 24 hours before testing the flow rate (Benin, Indo-1, Nigeria, SL-1, SL-2). MM-all and Nica-2 soak their filters for 12 hours (11%), seven factories (39%) reported soaking time ranging from 2 to 12 hours. Guate-1 soaks filters “until saturated” (6%) and three factories (16%) do not soak their filters before flow rate testing (DR, Tanz-1, Guate-2).

At five factories (n=14, 36%) water used for soaking filters is discarded every day (Cam-1, Guate-1, Indo-2, Tanz-2, and SL-2). At the Myanmar factories and Indo-2 (14%) the flow test water is reused but the water used to soak the filters is discarded daily. At four factories (29%) flow rate testing water is continuously reused (Indo-1, Nica-1, Cam-2, and Colombia). The Nigeria, Nica-2, and Indo-1 factories (21%) change the water between every 10 days and 2 months depending on the condition of the water. At Cam-2, there is no set protocol.

To measure flow rate, eight factories measure the change in water level in the filter using a T-device (Figure 8-2) (n=18, 44%) and eight factories (8, 44%) measure the amount of water collected in the receptacle after an hour, or after half an hour (Tanz-1). SL-1 did not describe their flow rate testing method. Factory-established acceptable flow rates range from 1.0-3.0 L minimum to 2.0-5.0 L maximum. Figure 3-11 shows the flow rate range accepted by each factory, the filter element capacity (L), and the depth of the filter element (cm).

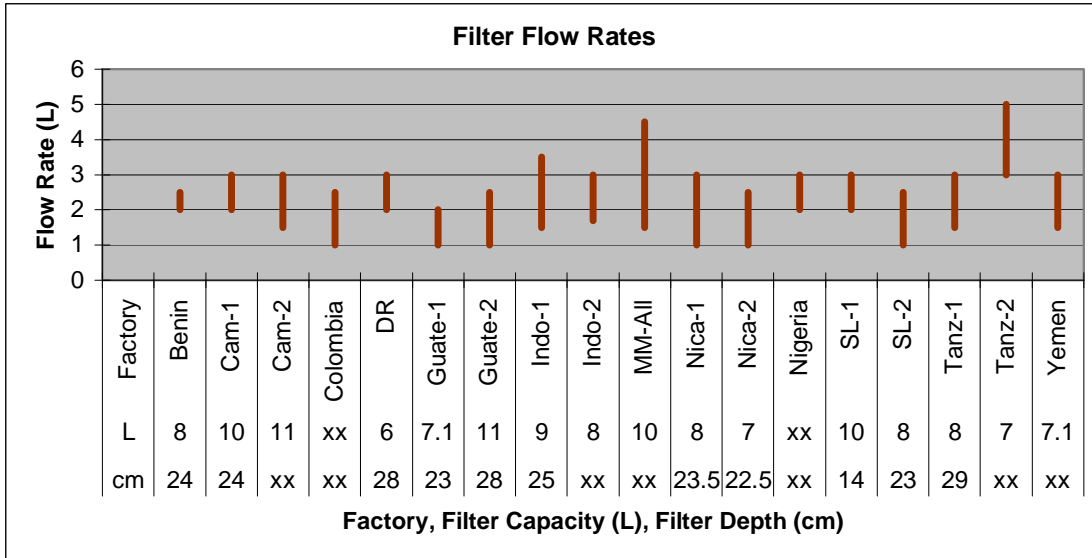

Figure 3-11: Flow Rate Ranges

### 3.10.3 Microbiological Testing

Thirteen factories report carrying out microbiological testing regularly (n=18, 72%); they test from 0.2%-15% (n=8, average 5%) of their filters. Four factories (22%) have carried out some tests on their filters (Nica-1, Nica-2, SL-1, and Yemen). Six factories (n=18, 33%) have tested their filters both in a lab and at the factory. Three factories (17%) only test their filters at the factory; eight factories (44%) only use laboratories. None of the respondents provided the data set regarding acceptable ranges for test results. Additional survey results on microbiological testing are presented in Annex C.

### 3.10.4 Filter Logs and Failure Rates

All factories record some production data (n=18, 100%) but only 13 factories (72%) always maintain logs. Between 12-14 factories (57%-88%) record the date made, filter number, batch number, and flow rate. One factory also records the operator, conditions, and origin of materials. Another factory documents information including filter weight, drying time, kiln temperature, visual faults, and filtration rates. With this information, firing curves, filtration rate distributions, and diagrams are created for analysis. A table showing which information is recorded on logs per factory is presented in Annex C.

The average total failure rate is 12% (n=15) (range 2%-27%, stdev 8%). Failure rates vary between 2% and 27% with five factories (33%) reporting a failure rate of greater than 15% (Figure 3-12). Only four factories record the reason for filter rejection.



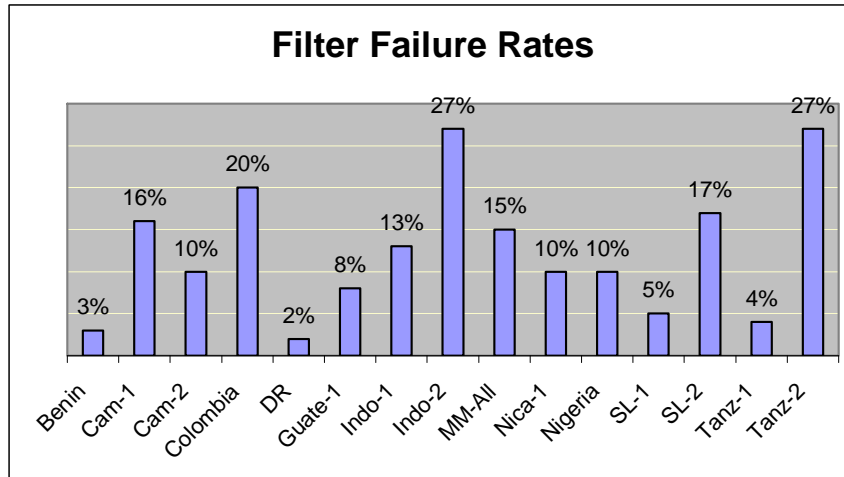

Figure 3-12: Failure Rates

Fourteen factories reported that they document filter flow rates. Ten factories reported that between 0%-17% of their filters do not pass flow rate tests (average 6%, stdev 5.3%), making this the number one reason for rejecting filters at seven of these ten factories. Between 0%-7% of filters are damaged during firing (average 2%, stdev 2.4%), 0%-1% from accidents and 0%-1% during drying. The average failure rate for these ten factories is 9%, ranging from 2%-20% (stdev 6.2%). Six additional factories mentioned either flow rate testing, firing, or both as stages when the majority of filters are rejected.

Of the three factories that reported other primary reasons for filters failing quality control, two (DR, Tanz-1) do not perform flow rate tests on 100% of their filters. These three factories reported the lowest total failure rates (Benin at 3%, DR at 2%, and Tanz-1 at 4%). Interestingly the third factory, Benin, which does perform flow rate testing on 100% of their filters, has the narrowest flow rate range of all the factories (2-2.5 L/hr) and reports one of the lowest total failure rates. Although at the Benin factory a production log is usually kept, only the date the filter is made is recorded. A lack of standardized quality control procedures and documentation complicates the comparison of failure rates and reasons for rejection across factories.

Cracks that appear after firing could be from a variety of causes including material characteristics, filter mixture ratio, mold alignment, drying conditions, or firing schedule. Figure 3-13 shows the percentage of filters that crack per firing at each of the factories. Eleven factories (n=18, 61%) reported that these rates are consistent. However, they are not consistent at the Benin, Guate-2, Nica-1, Nica-2, SL-2, or Tanz-1 factories.

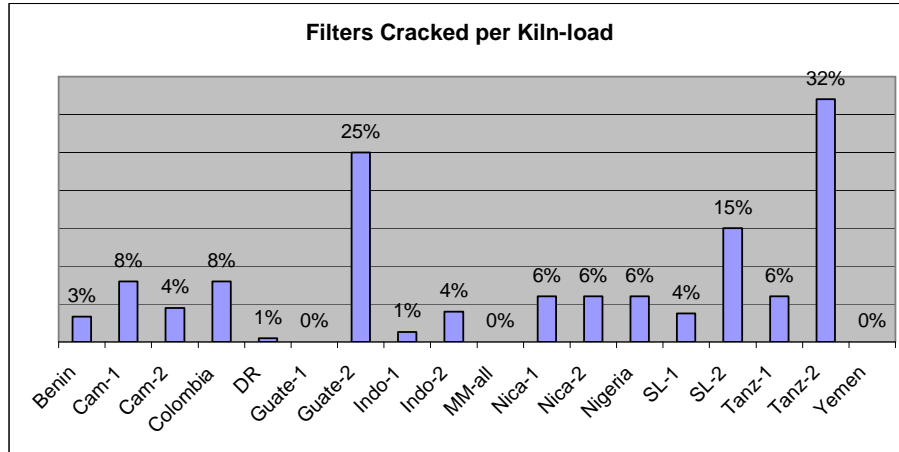

Figure 3-13: Filters Cracked During Firing

### 3.11 Health and Safety

#### 3.11.1 Materials Processing

As a part of their health and safety guidelines, all factories recommend that a dust mask or some sort of nose and mouth covering be worn while processing clay (n=16, 100%); however, only eight (50%) factories reported that employees always wear them. In addition, some workers wear gloves, goggles or glasses, ear protection, or closed toe shoes. At Cam-2, a fan is used to blow away clay dust. For processing burn-out material (n=15), 14 factories (93%) reported that their workers wear face masks, four (27%) reported that they wear goggles, two (13%) reported that ear protection is worn, and at two factories (13%) gloves are worn. One factory reported that no health and safety precautions are taken while processing burn-out material due to a lack of industrial health and safety guidelines. Ten factories (67%) reported that these precautions are always taken.

#### 3.11.2 Mixing and Pressing

While preparing filter mixture and pressing filters, eight factories (n=12, 67%) reported that their workers wear masks, three (25%) reported that their workers wear goggles, three (25%) reported that their workers wear gloves, and three (25%) reported taking few or no health and safety precautions. In addition, at SL-2, helmets are worn while mixing. At Cam-1, the press has an automatic stop system and the mixer has a pulley system installed to prevent injuries. At Cam-2, shoes are required, fans blow dust away, and the press is located at a distance from other factory activities. Eight (67%) factories reported always taking these precautions. Four factories (n=14, 29%) reported minor accidents, three of which specified hand or finger injuries.

#### 3.11.3 Firing

While firing kilns, workers at six factories (n=14, 43%) wear gloves, at five (36%) they wear face masks, at three (21%) they wear goggles or glasses, and three factories (21%) do not provide specific health and safety guidelines for firing kilns. Seven factories (50%) reported that precautions are always observed. In Nigeria, supplements and vitamins are provided for the kiln masters and firing days are rotated to allow workers to recover between firings.

### 3.11.4 Silver

The 13 factories that work with powdered silver reported that employees wear gloves (n=11, 100%), four (36%) wear face masks, and four (36%) use eye protection. Seven factories (64%) reported always taking these health and safety measures. Of the seven factories where workers work with liquid silver (n=5, numbers do not add up to 100% because three factories work with both liquid and powdered silver), at three factories (60%) they wear gloves, at two factories (40%) they wear face masks, at one factory (20%) aprons are worn, and at one factory (20%) no health and safety precautions are taken. At one factory, the workers did not like wearing gloves and so they no longer do. Three factories (60%) reported that health and safety precautions are always followed when working with liquid silver.

### 3.12 Summary

Manufacturing practices vary between factories. This is to be expected, as materials characteristics vary and challenges during normal production will require that practices be modified to troubleshoot and resolve inconsistencies. This technology was designed to be manufactured by artisans and therefore to be able to accommodate some variation in production.

Filters produced in different countries have different characteristics; however, as production information has not been available, it has not been possible to compare production variables on filter characteristics or identify the production variables that influence filter effectiveness. Limited research has been carried out to compare specific manufacturing processes with filter quality, findings have been contradictory, and results have not translated into manufacturing recommendations for improving filter quality. Research can help identify and understand the relationships between production variables that impact filter quality, including the influence of clay characteristics, burn-out particle size and particle size distribution, and firing schedule, so that factories can focus on controlling influential variables.

Manufacturing practices also vary within factories. While little information is available regarding the influences of many of the variables on filter characteristics, by controlling the consistency of materials, materials processing, and manufacturing practices, each factory should produce more consistent filters. The implementation of a comprehensive quality control program and the analysis of information collected on detailed production logs and results from regular microbiological testing will aid in troubleshooting and improving filter quality.

Figure 3-14 is a flow chart depicting the general steps in filter production. In the following chapters the filter manufacturing process is discussed in detail and best practice recommendations, which take into consideration information from the survey results and known information about ceramic production, are presented. Recommendations as to where further research can help refine best practice recommendations are presented at the end of each chapter.

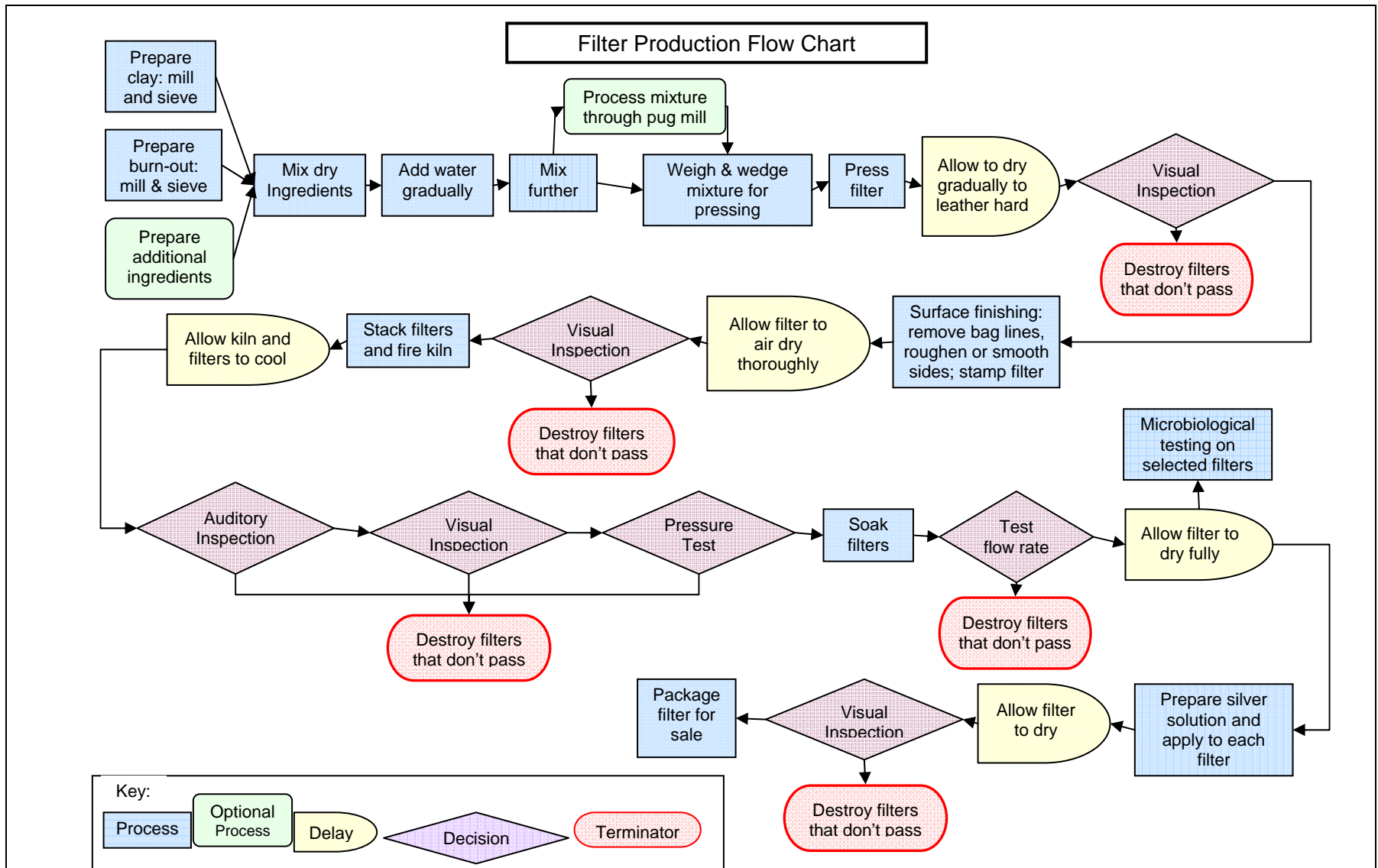

Figure 3-14: Filter Production Flow Chart

## 4 Variables: Materials Sourcing and Processing

The raw materials used to manufacture ceramic water filters include water, clay, and a burn-out material. At some factories sand, grog, or laterite is included in the filter mixture. This chapter describes the raw materials used in filter manufacturing, including materials characteristics, methods for evaluating raw materials, materials processing, and recommended documentation. Silver is covered separately in Chapter 7. A summary of recommendations and areas where further research is needed are listed at the end of this chapter.

### 4.1 Water

A reliable and reasonably clean source of water is required for both filter production and flow rate testing. A facility that produces 50 filters per day will require approximately 100 liters (27 US gallons) for production and 500 L (132 US gallons) for flow rate testing, daily. Additional water is needed for factory cleaning, maintenance, and to meet hygiene and sanitation needs of the employees. Filters should be set up at the factory to provide potable drinking water for employees. Water quality for silver dilution is addressed in Section 7.7.

At program outset, both production and flow rate water should have a full laboratory analysis carried out to test for heavy metals, inorganic chemicals, and microbiological contaminants so that the water used in the facility can be characterized and any concerns can be addressed up front. Testing should be repeated annually; however, if a factory is using an intermittent or less safe water source, testing should be conducted more frequently, with particular attention paid to locally occurring contaminants in the water.

Water can be recycled for soaking and flow rate testing as long as it does not become too turbid, as turbidity will influence the flow rate results and could contribute to clogging of the filters. Water should be visibly “very clear.” Turbidity can be measured using a turbidity tube or an onsite or laboratory turbidimeter and should be less than 5 nephelometric turbidity units (NTU). A rain-water harvesting system, a storage tank, and/or a recirculation system can help meet water demand; factories should consult a local contractor with experience designing such systems.

Water contaminated by some chemicals may leave toxic residues in filters that could leach into the filtered water. Also, heavy metals and inorganic materials might not fire out and could negatively affect filtered water. Although we do not know the source, arsenic has been detected in the effluent water from filters from some factories (Section 2.1.6). Due to the long-term health effects of arsenic consumption, all factories should test their water supply for arsenic. Arsenic testing can be carried out using field test kits (see Annex J for recommended tests) but it is preferable that samples, which should be properly collected in appropriate containers, be taken to a local laboratory for analysis. Although arsenic concentrations in filter effluent have been below the provisional WHO guideline value in some countries, indicating the leaching does not pose a health risk to filter users (Tun 2009), it is important to document the presence or absence of arsenic in both the source water and the filter effluent. If arsenic is present in filter effluent at concentrations above the WHO provisional guideline value, remedial action will be required.

## 4.2 Clay

The quality and characteristics of clay used in filter production are important, as they will influence workability, filter strength, shrinkage and propensity towards cracking and warping, porosity, and firing temperature. Sourcing, classifying, evaluating, preparing, and processing clay are discussed in the following sections.

### 4.2.1 Sourcing Clay

Clay quality and characteristics directly influence filter quality. It is important that filter producers evaluate clay at its source; clay taken for initial evaluation should be “sampled” from different positions in the mine to evaluate variability within the deposit. Filter producers should confirm that the clay used for filter production is consistent over time. To prevent interruption in filter production, an alternative clay mine with suitable clay should be identified for use in the event of a disruption in, or problem with, the main raw clay supply. Location is an important factor in choosing clay as the cost of mining and transportation can be significant. To keep production costs as low as possible, clay should be mined close to the workshop.

The Colombia factory reported that poor clay quality can result in a failure rate of over 20%.

Using unfired extruded bricks from industry can be a consistent and economical way to obtain clay, but this source will also need to be evaluated for its suitability for use in filter production. The physical requirements for brick clay (i.e. plasticity, workability, shrinkage rates) are different than for pottery clay. While the potter will look for a smooth, plastic clay, the brickmaker will prefer a clay that is much coarser and contains considerable amounts of sand or other nonplastic material so that bricks can be formed, dried, and fired without warping, cracking, or high rates of shrinkage. In some countries, due to the different requirements, pottery clays and brick clays are even called by different names and are considered different materials. Therefore, where producers rely on clay from brickmakers, it is important to see the clay source, discuss the mining practices, and evaluate the suitability of the material to ensure that the clay will have the appropriate characteristics for filter manufacturing, and that the source will be consistent and reliable. An advantage of using unfired extruded bricks is that the material will have already been screened and processed ensuring uniformity and increasing the plasticity of the material.

### 4.2.2 Classifying Clay

Clay can be classified by characteristics including origin (primary or secondary), firing temperature (refractory or fusible), maturation range (earthenware or stoneware), color (white, grey, red), and properties (plastic or short).

Generally clays are either primary, located near their mother rock, or secondary, having been transported by wind or water. Primary clays tend to be less contaminated with other materials; secondary clays are often more accessible. Clays can also be classified by the temperature at which they reach their fusion point, often referred to as vitrification. As clay vitrifies it becomes stronger but less porous, therefore the optimal firing temperature for each clay will be a balance between the desired porosity and desired strength.

Earthenware clays contain iron oxide and mineral impurities that cause them to reach maturity at relatively low temperatures (less than 1,100°C / 2,010°F) while remaining porous. These impurities also influence the color of the clay both in its raw and fired state. Earthenware clay typically has a narrow temperature range within which it reaches maturity, and therefore it requires a more even and controlled firing than a clay with a broader range, such as stoneware. Traditional potters typically work with earthenware clay and it is also the common raw material for building materials such as brick, floor tile, and roof tile (Rhodes 1973: 22). Porosity, along with common availability, makes earthenware clays the most suitable for ceramic filter production. Refractory clays, such as stoneware, porcelain, and fireclay, mature at temperatures from 1,200°-1,800°C (2,190°-3,270°F), have a long maturation or vitrification range, are relatively non-porous at maturity, and therefore, are not as suitable for making filters.

Properties, such as plasticity, influence the workability of a clay. Plasticity, the ability of the clay particles to slide, is influenced by particle size, purity, moisture content, particle uniformity, plasticizers, and strength of particle bond (Hamer and Hamer 2004: 270). These characteristics also influence the wet and dry green strength, the amount of shrinkage and propensity toward warping or cracking in the drying or firing processes, porosity, and the fusion point. Materials can be blended to form a clay body with sufficient plasticity, that holds its shape, has a reasonable rate of shrinkage, has the desired porosity, that doesn't warp or deform while drying or during firing, and that matures at the desired temperature.

#### 4.2.3 Particle size

Clay particles are typically plate-like, hexagonal in shape and range from 0.05 to 3  $\mu\text{m}$  across, although the definition of clay based on particle size varies across disciplines. The particle size directly influences the plasticity, strength, and shrinkage of the clay. Two chemically similar clays, with different particle sizes, will react differently. A clay with a smaller particle size (0.02 to 1.0  $\mu\text{m}$ , ball clay) has the potential for a higher moisture content because of the greater surface area coated with water in the plastic state. It will therefore shrink more in drying and be more likely to warp or crack. In firing, a clay with smaller particles will interact more readily with fluxes and be less resistant to the effects of temperature and time than clay with larger particles (0.5 to 20  $\mu\text{m}$ , China clay) (Hamer and Hamer 2004: 253).

At Cam-1 and Indo-2, clay is tested for plasticity and prototypes are fired and evaluated for cracking, breaking, firing temperature, and filtration rates.

#### 4.2.4 Purity

The proportion and type of impurities, or nonclay particles, will affect how the clay behaves during different stages of the process. Some impurities could make the clay unsuitable for use; others could be beneficial, up to a point. Common impurities in clay include the following:

- 1) **Iron:** Often found in surface clays, iron is usually not a problem unless it is coarse or nodular. It can contribute to the color and to lowering the maturing temperature of the clay and could contribute desirable virucidal qualities to the filter (Sections 2.1.3 and 4.6).

- 2) **Sand:** High sand content correlates with low plasticity in clay and too much sand can cause filters to become brittle and break. Sand can also increase the flow rate, though we do not know how it affects the efficacy of the filters. In very plastic, fine grained clays, the addition of sand might aid even drying and reduce shrinkage. The addition of grog or laterite will have a similar effect.
- 3) **Soluble salts:** If present in the source clay, soluble salts migrate to the surface of the finished product over time causing white discoloration. The presence of a white scum on the dried clay usually indicates the presence of undesirable alkalis (Rhodes 1973: 65). This has not been found to affect filter quality, but could be of aesthetic concern.
- 4) **Lime:** In firing, lime changes from calcium carbonate to calcium oxide, which can hydrate (absorb water from the atmosphere), causing it to swell and break off, a condition known as "lime popping". Clay that contains whitish lumps can be tested for lime as described in Annex D; however, thus far lime has not been observed or reported as an issue in finished filters.
- 5) **Heavy metals/inorganic materials:** Examples include arsenic, fluoride, and cyanide. Contaminants in the materials used to manufacture filters raise two issues: 1) the possibility that the filter element itself could introduce contaminants into the filtered water; and, 2) the safety of workers exposed to toxins present in the materials they use daily. Raw materials and filtered water should be tested in a laboratory for possible contaminants.
- 6) **Organic matter:** High levels of organic matter (such as leaves or twigs) in the clay can affect the strength and integrity of ceramic filters since this material will burn out during firing and can create large, unregulated cavities. Organic material is usually removed during clay processing (milling and sieving).

#### **4.2.4.1 Moisture content**

Moisture content can account for as much as 40% of the weight of plastic (wet) clay and will influence workability, drying, and firing. Clay contains three types of water:

- 1) **Water of plasticity** is the lubricant between clay particles that helps them slide and stick to one another. It accounts for between 10%-30% of the weight of clay depending on the clay particle size. Smaller particles provide a greater surface area that can be surrounded by water, therefore, more water of plasticity means the clay will take longer to dry and will shrink more as there is more water to evaporate.
- 2) **Pore water** can account for as much as 10% of the weight of clay when it appears dry. It evaporates as the clay is heated, usually by the time the clay is heated to 120°C (250°F).
- 3) **Bound or chemical water** is part of the chemical structure of clay. It comprises about 14% of the weight of dry clay, and fires out at around 600°C (1,110°F). When this water is removed, clay becomes a pot (Section 6.8.4).

During firing, as the water is driven off at 100°C and 600°C, the wares will experience added stress; therefore, attention will be required at these stages to avoid cracking (Section 6.8).



#### **4.2.4.2 Particle Uniformity**

In general, fine clays of a predominantly small particle size will be more plastic and have good dry strength but will shrink more due to the high water content, and therefore be more prone to warping and cracking during drying. They will also be less porous. Clay with a high shrinkage rate (more than 15%) probably will not be useful, due to warping and cracking in drying and firing. Coarser clays of a predominantly larger particle size will be less plastic, will exhibit less dry strength, and will result in a noticeably coarser and more porous product, but will shrink less and dry more evenly with less cracking and warping. Ideally, a clay body should have a variety of particle sizes in order to create an overall particle size distribution that will maximize the strengths and minimize the weaknesses of each. An optimal clay body will have the desired plasticity, a reasonable rate of shrinkage, good wet and dry strength, the desired texture and porosity, and experience minimal warping and cracking in the drying and firing processes.

#### **4.2.4.3 Plasticizers**

Local potters know the plasticity required for their normal production line but the innate plasticity of clay for filter production is even more important since 40% to 60% by volume of fine, nonplastic, burn-out material is added to the clay. This drastically reduces the plasticity, affects the workability of the original clay, and makes filter production a counterintuitive process for potters. Though plasticity is common in surface clays, if necessary, a plasticizer such as bentonite, if available locally, can be added to improve plasticity.

#### **4.2.4.4 Strength of Particle Bond**

The strength of dry, unfired clay varies greatly. An object made from ball clay (which is very plastic), for example, may be six or seven times stronger than one made from Georgia kaolin clay (low plasticity). The property of dry strength is directly related to particle size, the smaller the particle size, the stronger it will be in the dry state, but dry strength is also related to the strength of the particle bond. A very plastic clay with insufficient strength will not hold its shape and a strong clay will tear if it is not plastic enough. The strength of the particle bond can be improved by bringing the particles closer together by wedging filter mixture and processing it through a pug mill.

#### **4.2.5 Evaluating Clay**

Evaluating clay helps to determine the suitability of a clay source, provides baseline data to compare with future clay sources, and helps determine which characteristics need modifying to improve the clay or filter mixture. Many of these evaluations should be carried out regularly on both clay and filter mixture to monitor the consistency of raw materials. Detailed instructions for several of these tests are presented in Annex D. A brief description of each test follows.

**Plasticity** A common rule of thumb (by no means limiting) to evaluate plasticity is: roll out a coil of clay about the diameter of your small finger, form a ring approximately one-inch in diameter and note if the clay cracks and if it holds its shape. If the clay holds its shape and there is no initial cracking, the clay is probably plastic enough to start tests.

**Particle size distribution** can be observed by adding a half a teaspoon of powdered clay to a glass container (about 500 mL) half-filled with water. Shake until the clay particles are in suspension then add water until the bottle is almost full. Shake again. Place the bottle at a slight angle. The heavy materials will settle almost immediately and identifiable layers will appear near the tilted side of the glass as more settling occurs. With a plastic clay containing fine particles, the water will remain cloudy for at least two hours and will take at least a day to completely settle. Although a more detailed particle size distribution analysis might be useful, this can be helpful for general clay comparison.

In Somaliland particle size analysis is carried out by using a hydrometer to measure the density of a clay suspension at specific time intervals as it settles. The percentage of clay, sand, and silt is measured and recorded. The information is used to blend different clays to produce a clay body with the desired characteristics and to monitor clay consistency.

**Sand content** can be determined by settling the sand out of a thin slurry of clay, passing it through a sieve, and weighing the ratio of clay (plastics) to sand (nonplastics). Alternatively, when dry screening clay, the discarded material can be weighed and compared with the amount of sieved material. The desired amount of sand will depend on the plasticity and grain size of the clay and the results of prototype testing. If the filter shrinks too much or exhibits drying or firing cracks, sand can be added to the point where the problem is solved. If the clay contains too much sand, the filter will not shrink enough and/or will be too porous. If this is the case, the sand can be removed by dry screening, which will also remove large pieces of organic matter. Alternatively, the clay can be combined with a less sandy clay, or another source of clay should be found. Any modifications to the source clay or filter mixture must be confirmed with microbiological testing of fired filters.

**Water of plasticity** (Annex D) will vary for each clay and will range from 10% in low plasticity clays to 30% in highly plastic clays. It will be influenced by both nonplastic materials and the predominant clay particle size, with smaller particles providing more surface area that can be surrounded by water. The water of plasticity can be evaluated by measuring the amount of water required to get the clay into a plastic state. Clays that have a higher water of plasticity will take longer to dry and will shrink more.

**Shrinkage of dried clay** (Annex D) will be affected by the amount of nonplastic material, the particle size of clay, and the water of plasticity. Shrinkage can be determined by measuring the change in size of a test piece of clay once it has dried.

**Dry clay strength** can be evaluated by making a series of small tiles and estimating the amount of force required to break them once they are dry. In a laboratory, a more accurate test can be carried out with a machine that measures the modulus of rupture.

**Shrinkage of fired clay** (Annex D) can be determined by measuring the change in size of a test piece of clay once it has been fired and both the pore and the bound water have been fired out. Once the firing shrinkage has been determined, the total shrinkage can be calculated. In Myanmar, the clay shrinks approximately 10%-14%, while the filter mixture shrinks about 5%-6%.

**Firing range of a clay** can be identified by evaluating characteristics of test pieces fired to different temperatures. The strength of fired clay can be estimated by breaking a series of test

pieces fired to different temperatures. Each piece is broken over a white piece of paper and inspected for carbon powder or a carbon line in the profile, which indicates incomplete firing. The profile of the clay along the break should be of a consistent color and texture. The effort required to break each piece is also estimated. If a test piece is difficult to break it can be placed across a pencil and pressure applied on both sides. The test pieces should be increasingly difficult to break with increased firing temperature; however, if overfired to the point where glass has formed, they will become brittle. The sound created as a piece is broken will also vary with temperature: underfired pieces will break with a duller sound while the sound will be more crisp for pieces fired at higher temperatures (Cuff 1996).

Shrinkage and porosity of test pieces fired to different temperatures can be measured and compared to evaluate the firing range of a clay; instructions for carrying out these tests are in Annex D. The porosity of the source clay will influence the amount of burn-out material required in the filter mixture. These tests should also be carried out regularly on filter mixture to confirm the consistency of the materials and processes. The porosity of filters manufactured in different countries ranges from 30%-44% (van Halem 2006; Oyanedel-Craver and Smith 2008).

#### **4.2.6 Arsenic in Clay**

Arsenic is released naturally into some clay by, for example, microbes and volcanic eruptions. It is also released during mining and it is found in some pesticides. The melting point of arsenic is 817°C (1,503°F) which is very close to the firing temperature at most filter factories, so it is possible that arsenic will not be a concern after being fired to this temperature. However, since its melting point is close to the maximum firing temperature, it is also possible that special precautions such as a longer soak time in the firing would be needed to guarantee a proper melt. Raw clay or ceramic pieces can be tested in a local laboratory or sent to Vinka Craver at the University of Rhode Island for laboratory analysis (Annex J). Filter effluent should also be tested for arsenic, see Sections 2.1.6 and 8.3.6.2.

#### **4.2.7 Preparing a Clay Body**

The materials that go into the formulation of a blended clay body can be thought of as plastics (clay), fillers (burn-out material, sand, and grog), and fluxes (oxides). A suitable clay body can be created by combining clays from different sources. Experience and experimentation will aid in developing clay bodies and filter mixture formula. Detailed instructions for line and triaxial blending are presented in Annex D.

Factors that can influence the plasticity of a clay body are its composition, wetness, aging, and bacteria. Since clay for filter making is processed dry, the best way to increase plasticity, if needed, is to add a more plastic clay. If available locally, up to 2% by weight of bentonite, a highly plastic montmorillonite, can be added.

Fillers are nonplastic materials that can be added to clay to increase stiffness, decrease warping during drying and firing, and decrease shrinkage. Fillers typically used in pottery production include sand and grog. Grog can be made from grinding and sieving fired clay,

In Nigeria, university students evaluate clay in a laboratory by testing for shrinkage, ease of use, firing temperature, filtration rates, and materials composition.

failed fired filters, or fired bricks. Some factories have found the addition of sand or grog helpful in achieving desired flow rates (Section 4.6.2). Burn-out material added to the filter mixture to create porosity can be considered a specialized type of filler as it will contribute to the desirable properties associated with coarser clays including the regulation of porosity, shrinkage, warping, and cracking. Adding fine nonplastic material to a clay will decrease its plasticity more than coarse materials, so if filters tend to tear during pressing, excluding some of the very fine burn-out particles from the filter mixture may help.

Fluxes are alkaline oxides that interact with glass-forming silica (already present in clay) and lower the fusion or vitrification point. In earthenware clays, which are typically used for filter production, the high oxide content creates sufficient fluxing action so additional fluxes are not typically needed. However, the clay or filter mixture can be too fusible, meaning it becomes too dense or brittle at the desired firing temperature; in this case a more refractory clay with less flux in it can be used, or a fine grog can be added.

#### **4.2.8 Summary**

In summary, the quality and characteristics of the clay used to produce filters will affect the quality of the final filter, and clay sourced from the same mine might vary in characteristics depending on the location in the mine. Therefore, clay should be evaluated regularly for consistency. Although some clays will be suitable with minimal processing, others will benefit from being mixed with another clay or with nonclay materials so that the resulting mixture has sufficient plasticity, a reasonable rate of shrinkage, good wet and dry strength, the desired porosity, experiences minimal warping and cracking in the drying and firing processes, and will mature at the desired temperature. The addition of burn-out material to the clay will influence these characteristics. Experimentation and experience will aid in clay body and filter mixture preparation. Any modifications to the filter mixture should be confirmed with microbiological testing of final filters.

### **4.3 Clay Processing**

The objective of clay processing (milling and sieving) is to remove impurities such as sand and organic matter. Dried, powdered clay will also absorb water more readily. Powdered clay is formed from raw clay by: 1) drying the clay in the sun; 2) precleaning the clay; 3) pulverizing the clay; and, 4) sieving the clay.

About 4.5 kilos (9.9 pounds) of powdered clay is required for each filter, so a factory producing 50 filters a day will need to prepare 225 kilos (500 pounds) of dry, powdered clay daily. Extra clay should be prepared and stored to prevent an interruption in production in the event of equipment breakdown, interruptions in the power supply, poor weather, or other unforeseen events. Prepared clay can be stored in 25-kilo (50 pound) sacks in a dry, raised, covered location, protected from moisture.

The materials needed for clay preparation include an area protected from rain, a shovel, a wheelbarrow, sacks, a hammermill, scoops, and a 25 or 30 mesh sieve (equivalent to 0.7-0.6 mm openings, see Tyler mesh equivalent chart in Annex B). It is important that equipment is inspected regularly and sieves are inspected daily. Employees should have access to replacement parts, and materials and resources should be available for repairing or replacing

damaged parts or equipment. Worker safety items needed for clay preparation include fan(s), face masks, goggles, gloves, earplugs, and closed shoes.

Although it is possible to dry the clay (and burn-out materials) in the sun on a sheet of plastic, in practice, plastic will trap moisture and impede complete drying, which will make pulverizing difficult. It is therefore preferable to sun-dry the materials on a cement slab.

Since clay put through the hammermill should not exceed 2 centimeters (3/4 inch) in size, large clumps of dry clay should be broken up with a hammer or tamper such as an “elephant’s foot”—a heavy metal plate attached to a heavy bamboo handle (Figure 4-1). Rocks and organic material should be removed from the clay.

A hammermill is used to pulverize the clay. It pounds the clay pieces with turning metal hammers. When clay particles are small enough, they pass through the hammermill screen and discharge as fine powder. A flail type hammermill without fixed blades is preferable as the blades are less likely to get damaged if nonmillable material is introduced. Hammers on each shaft must be adjusted relative to the others so that the mill will be balanced.

The hammermill should be located in a low-traffic area of the factory, preferably outdoors under a roof, so as not to pose a hazard to other workers. A fan can be used to blow away the dust generated.

Before operating the hammermill, the screen should be checked and replaced if broken or punctured, and a sack should be well secured to the outlet of the hammermill to collect the clay and minimize dust output. The hammermill should be running before adding material and only a small amount of material should be added at a time to prevent the machine from jamming. A lid (or a square wooden bat with hole in middle) can be used to cover the hopper to prevent clay from spitting out of the hammermill. Loud or strange noises that occur during operation of the hammermill may be due to rocks, wood chips, or other materials in the hammermill chamber. In this case, the machine should be turned off, disconnected from the power source, the cover opened, and the screens inspected. Any foreign material should be removed and discarded. If the screen or any other components have been damaged or punctured, they should be replaced before restarting the hammermill.



Figure 4-1: Elephant’s Foot Tamper (Hagan et al. 2009)

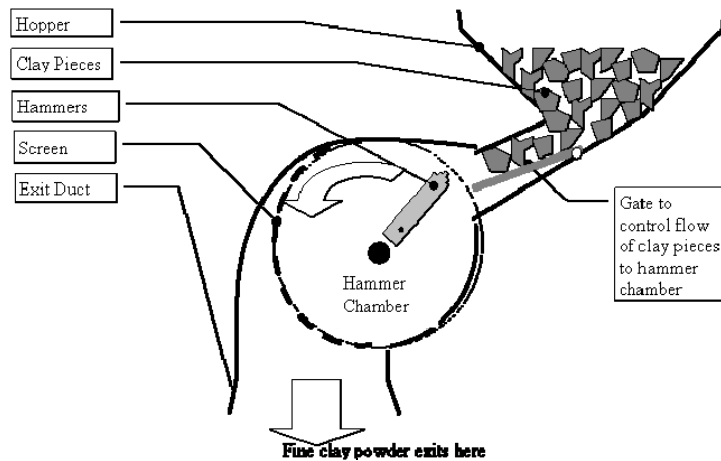

Figure 4-2: Hammermill Diagram (Mossman and Lam 2004)

Since hammermill screens are generally larger than the required 30 mesh (0.55 mm), after being processed through the hammermill clay should be sieved using the appropriate mesh. To facilitate sieving, a 25 or 30 mesh screen can be attached to a wooden frame. Clay that does not pass through the sieve can be remilled and sieved again. Material that does not pass through the sieve the second time should not be used in filter production. Sieves should be inspected daily for holes and repaired or replaced if damaged.



Figure 4-3: Hammermill Screen (source unknown)

Health and safety measures while processing clay must be strictly enforced as the inhalation of silica particles can cause silicosis (Section 4.3.1). In addition to following national or local health and safety guidelines, workers should wear face masks at all times while working with or near clay. While operating the hammermill, a facemask, earplugs and protective eyewear should be worn, long hair should be tied back, and loose clothing, which could get caught in the rotating machinery, should be avoided. A large amount of fine dust is produced during operation of the hammermill, so collection bags should be properly secured to hammermills to minimize dust output and clay processing equipment should be strategically located. Airborne silica dust can travel and remain suspended for several hours, so nearby workers not directly involved in clay processing may be exposed to the silica dust and should take appropriate preventative measures. Preventative measures should be taken not only while processing clay but also during cleaning the production area. Sweeping (dry brushing) will cause settled particles to become airborne, so water should always be used while cleaning. Although wet processing of clay is possible, and more considerate to worker health, wet processing guidelines for filter production have not yet been established.

#### 4.3.1 Silicosis

Silicosis is a long-term health risk associated with the inhalation of crystalline silica dust present in clay. It is an irreversible lung disease and can progress even when exposure has

stopped. The list of long-term health effects associated with the inhalation of silica dust includes asthma, silicosis, lung cancer, cardiovascular issues, and premature death. Inhalation of any airborne particles should be minimized, but silica is particularly dangerous and can remain airborne for several hours. Although workers should be provided with facemasks and protective goggles and instructed to use them, in practice they may avoid doing so due to discomfort. It should be emphatically communicated to employees that the importance of avoiding the long-term health risks from inhaling fine silica dust on a daily basis outweighs the short-term discomfort of wearing a facemask.

#### 4.4 Burn-out Material

The burn-out material fires out during the firing process and leaves behind small voids that increase porosity. Factories select the burn-out material based on local availability. Sawdust and rice husks are the most common materials used in local ceramic filter manufacturing, but millet husks, coffee husks, peanut husks, paper pulp, and other organic material that can be pulverized to a suitable size can be used.

It is generally known that different types of burn-out (sawdust vs. rice husk, for example) can impart different qualities on the filter mixture. Sawdust from different types of woods may also have different effects on the filter. Chemicals, such as residues from treated lumber, might be consumed in the firing or they could remain in the filter and contaminate the filtered water; therefore, sawdust from treated lumber should be avoided.

Indo-2 found that using sawdust as a burn-out material increased shrinkage too much yet Cam-1 expressed a preference for sawdust since the filters appear smoother and are nicer looking.

In order to produce consistent filters, factories should use the same type of burn-out material with similar characteristics throughout production and process it consistently. Evaluations should be carried out regularly and characteristics documented. When a new burn-out material is used, or the material varies in characteristics, filter efficacy should be confirmed with microbiological testing (Section 4.7).

The Dominican Republic factory found that sawdust from oak left an oily residue on the fired filters and resulted in a reduced flow rate. The Nigeria factory, however, uses oak sawdust successfully.

#### 4.5 Burn-out Material Processing

The processing of burn-out material is important since the pores created by the burn-out material form the path water travels through the filter walls. The burn-out material should be inspected visually after receipt from the supplier and regularly during production to ensure the material has consistent characteristics and consistent particle size distribution. There should also be no foreign material (rocks or pieces of wood) present in the burn-out.

The amount of burn-out material required per filter will vary depending on the established ratio. In Nicaragua, approximately 27 kg (59 pounds) of sawdust per day will be used to produce 50 filters. Prepared burn-out material can be stored in 25-kilo (50-pound) sacks in a dry, raised, covered location, protected from moisture.

Equipment needed for processing burn-out material will depend on the characteristics of the material received and the processing required, but in general includes an area that is protected from rain, scoops, sieve(s), sacks, and a grinder, blender, or hammermill with sharpened blades. It is important that the equipment is inspected regularly and the sieves be inspected daily. Resources for repairing or replacing damaged parts or equipment should be readily available. Worker safety materials needed for burn-out preparation include face masks, goggles, gloves, earplugs, and closed shoes.

The Nigeria factory has successfully used a kitchen blender to increase yield from sawdust and as an alternative, SL-2 uses a chili grinder for milling rice husks.

At a minimum, burn-out material should be sun-dried and sieved with a 30 mesh screen. If the best available burn-out is coarse or is not predominately of the desired mesh size it must be milled or ground before sieving. Some factories have two hammermills, but a hammermill with a 5 horse-power reversible motor can be adapted for burn-out processing by sharpening the reverse side of the hammers to a sharp point (at about a 60 degree angle) and then tempered by heating them in the embers of the firebox; once they reach the color of the embers, they can be removed and quenched in water or oil. The same hammermill can be used with the motor rotating in one direction to mill the clay, and in the opposite direction to mill the burn-out. By reversing the direction of the motor, the sharp ends of the hammers will mill the burn-out material to a finer particle size. The hammermill should be running before adding material, and only a small amount of material should be added at a time to prevent the machine from jamming. Alternatively, a chili grinder or kitchen blender can be used to mill or grind burn-out material.

At Indo-2, two sieve sizes are used to eliminate both the larger and finer particles.

Sieving burn-out with only one screen will not create a uniform burn-out particle size as there is still no control of particles smaller than the sieve used. Although defining an appropriate particle size distribution for the burn-out material requires further research, the exclusion of very fine burn-out particles might be helpful as these particles could have a negative effect on the plasticity and thus the workability of some clays. Sifters, like the ones used in Myanmar (Figure 4-4), can be manufactured locally and used to efficiently sift using two or more mesh sizes. As the handle is turned, the sloping screens vibrate. The coarser particles stay on the top screen and the very fine particles fall through the bottom screen, leaving the burn-out material for the filter mixture on top of the bottom screen. As with clay, the coarser material can be remilled and resifted.



Figure 4-4: Burn-out Sifter (Thirst-Aid 2010)

Ideally, a custom, consistent mixture of burn-out particle sizes would be formulated by combining appropriate amounts of representative particle size ranges. Particle sizes would be classified using sieves of different sizes (perhaps 16, 30, and 60 mesh screens). Although this



could achieve a consistently high control of the particle size distribution of the burn-out material, it could increase labor requirements. Further research is needed to determine if there is an ideal particle size range as well as the appropriate quantities for each particle size.

In addition to following national or local health and safety guidelines, workers should wear face masks for protection against inhaling airborne particles and goggles to protect their eyes from dust and material that spits from the hammermill when processing burn-out material. Earplugs should be worn when using a mill or other loud machinery, long hair should be tied back, and loose clothing, which can get caught in machinery, should not be worn.

## **4.6 Additional Materials and Processing**

### **4.6.1 Laterite**

Some factories add laterite to the filter mixture. Laterite is high in goethite and other iron oxides, which may improve filter effectiveness against viruses, but more research is needed on additives such as laterite to confirm whether virus removal is improved (Section 2.1.3). Laterite may be included in the filter mixture at the filter factory's discretion. Laterite is processed similarly to clay: dried, powdered, sieved to 30 mesh, and included in the dry mixture. The inclusion of laterite will increase both the porosity and the weight of filters; no more than a ratio of 1:6, by weight, of laterite to clay, should be added or the structural stability of the filters will be compromised (Brown and Sobsey 2009). If laterite is included, the filter mixture ratio must be confirmed with microbiological testing of finished filters and it should be processed consistently and included regularly.

### **4.6.2 Grog and Sand**

In normal ceramics production, grog, which is previously fired ceramic material that has been ground into a powder and screened for consistent size, is often added to clay to decrease plasticity, improve workability, and reduce cracking during drying and firing. Grog also decreases shrinkage and increases porosity. Grog can be made onsite by grinding crushed, fired bricks or rejected, fired filters in the hammermill and then sieving it for desired mesh size (approximately 20 or 30 mesh). If used in filter production, grog should be included in the dry filter mixture; it should be processed consistently, included regularly, and the filter mixture ratio must be confirmed with microbiological testing of finished filters.

The amount required, will depend upon the characteristics of the local clay and burn-out material. At Guate-2, filters did not develop sufficient flow rates with the expected range of sawdust usage; therefore, grog was added to the mixture. Up to 33% (by volume) of the clay portion of the mixture (two parts clay to one part grog) was needed to make filters with satisfactory flow rates. In Laos they have found that including up to 5% grog (by weight) improves the filtration rate, but when 10% was added, the filters were weaker (Cohen 2010b).

Sand, if clean, can be used as an alternative to grog. It should also be sieved and included in the dry filter mixture before adding water. If including sand or grog in filter mixture, a reliable and consistent supply should be available. The filter mixture ratio should be confirmed with microbiological testing and used consistently.

## 4.7 Material Evaluation, Documentation, and Storage

Materials including clay, burn-out material, and additional materials included in the filter mixture should be evaluated during the initial sourcing of raw materials and their characteristics should be documented (Table 11). Raw materials should be monitored continuously. Characteristics should be evaluated and documented at least once per year or whenever a variation is observed in materials or filter characteristics. Changes in materials characteristics require that the efficacy of completed filters be confirmed with microbiological testing to ensure that the final product has not been impacted by the changes. In addition to microbiological testing, testing for heavy metals and inorganic chemicals in both raw materials and in filter effluent is recommended when source materials change. If changes to materials are recognized and evaluated early, testing can usually be carried out concurrently with continued production; however, if variation is not identified until filters begin to fail quality control tests, then the factory could lose a large number of failed filters, have a greater challenge identifying the cause of failure, and production could be interrupted while new materials are sourced and tested.

Baseline data for clay should be recorded on a clay evaluation log (Annex G) and stored for comparison with future clay analyses. The evaluation should include the clay source and the level in the mine, a description of the raw clay, processing carried out, the proportion (by weight) of discarded material, results of water of plasticity, water absorption, and dry, fired, and total shrinkage tests.

As with clay, baseline data for burn-out material should be documented and stored for future comparison. The evaluation should include a general description of the burn-out supply including type (if sawdust, the type of tree and if rice husk, which part of the husk), supplier, processing that has been carried out by the supplier, particle size received, particle size used in filter production, grinding or milling procedure used, and sieving procedure used. In addition, burn-out should be tested for moisture content and contaminants (Annex D). Employees responsible for collecting, receiving, processing, and mixing materials should carry out a visual inspection and report variation, including color, texture, size, smell, presence of a coating or oils, clumping, along with any other indicator of change in the burn-out material. Visual inspection should also monitor the presence of unwanted materials in the supply (i.e. rocks, trash) which should be removed. Causes of inconsistencies should be identified (i.e. hole in sieves, blades needing sharpening) and corrected. Inconsistencies should be identified and corrected as early in the process as possible to minimize the effect on production.

Any additional materials added to the filter mixture, such as sand, grog, or laterite, should also be monitored, evaluated, and documented. Characteristics of these materials should remain consistent with the characteristics of the material used to manufacture prototype filters during ratio formulation. Any changes in materials or processing should be supported by microbiological testing of finished filters.

Materials approved for use and materials that have been rejected must be labeled and stored in different locations. Materials approved for use should be stored in a location that: 1) is convenient for the flow of production; 2) has sufficient space; 3) accounts for airborne contamination pathways; 4) is protected from the elements; and, 5) is protected from contamination.

## 4.8 Recommendations

Based on the knowledge summarized in the previous sections, the following recommendations are made to filter manufacturers by the Working Group:

- 1) A reliable source of reasonably clean water is required for filter manufacturing. Both production and flow rate water should be tested for heavy metals, inorganic chemicals, arsenic, and microbiological contaminants. In addition, flow rate water should be evaluated for turbidity. Water should be tested at project outset and yearly, or more often if the factory is using an intermittent or less safe source.
- 2) A reliable source for raw materials including clay, burn-out, and any additional materials included in the filter mixture should be identified. Materials should be evaluated during initial sourcing, then yearly, when characteristics vary, or if a change in filter quality is observed. Evaluations should be documented and analyzed. Variation greater than 10% or a change in filter characteristics or quality should be followed up with microbiological confirmation of filter effectiveness.
- 3) Clay should be processed onsite to a consistent powdered form using a 25 or 30 mesh sieve.
- 4) A reliable source of consistent burn-out material should be identified and sieved to 25 or 30 mesh.
- 5) Additional materials, such as sand, grog, or laterite, if included in the filter mixture, should be processed and included consistently according to the factory filter mixture ratio.
- 6) Materials should be stored safely, under appropriate conditions.
- 7) Employees should be required to follow national and local health and safety regulations. Those exposed to airborne particles should be required to wear face masks, remembering that very fine silica dust can remain airborne for several hours.

## 4.9 Areas for Further Research

The following areas require further research in order to refine recommendations for best practice in ceramic water filter production:

- 1) Does the presence of arsenic, fluoride, or other chemical contaminants in water or other raw materials used to manufacture the filter contribute towards contamination of filtered water? Are they influenced by different firing temperatures?
- 2) What are possible additives or coatings that can make filters effective against viruses? What are simple means of identifying and processing them?
- 3) How do different types of clay microstructures affect fired filter strength, potentially influencing breakage rates? How can they be evaluated or influenced at a local level?
- 4) Does the use of unfired commercial bricks or unfired, failed filters in filter mixture affect filter performance?

- 5) How do different burn-out materials (sawdust vs. rice husks vs. peanut shells) affect filter performance including workability of the mixture, flow rate, appropriate clay to burn-out material ratio, and microbiological efficacy? Do some burn-out materials leave a residue in the filter?
- 6) How does variation within a given burn-out material (such as different types of trees for sawdust or different parts of rice husks) affect flow rate, appropriate clay to burn-out material ratio, and microbiological efficacy?
- 7) What role does particle size of the burn-out material play in pore structure and hydraulic properties? Is there an ideal particle size range for burn-out material?

#### **4.10 Chapter Details**

The information for this chapter was collated by Robert Pillers and Burt Cohen and expanded upon and edited by Justine Rayner and Daniele Lantagne. Participants on the conference call to discuss this chapter included: Terry, Mike, Justine, Daniele, Robert, Burt, Susan, Lisa, Tracy, Vinka, and Manny.

## 5 Variables: Filter Production

In this chapter, the filter production process is presented. It includes maintaining production logs, establishing the filter mixture ratio, mixing, pressing, surface finishing, and drying. This chapter concludes with best practice recommendations for filter production and suggestions for further research. Kilns and firing are discussed in Chapter 6.

### 5.1 Production Logs

The consistency with which each of the manufacturing steps is carried out will directly affect the consistency of the filters produced; however, since some variation will occur, material evaluation, production, and firing logs should be used to record detailed production information throughout the production process. This will also encourage attention to each process and consistency in production. The logs can be referenced to repeat the production of high performing filters, to troubleshoot variation or inconsistency in finished filters, and as a reference for researchers evaluating filters in the field or a laboratory. Examples of various logs are included in Annex G which can be used as models; however, each factory is encouraged to modify them to suit their flow of production. Recommended data to record is suggested throughout the following sections.

Indo-1 implemented Statistical Process Control procedures whereby filter weight, drying time, kiln temperatures (6 positions), visual faults, and filtration rates are documented. Firing curves, filtration rate distributions, and diagrams are created for data analysis.

### 5.2 Establishing Filter Mixture Ratio

It is advisable to visit a fully operational factory before starting production. During production start-up, factories should work with an experienced ceramic filter technician to aid in determining the appropriate filter mixture ratio for raw materials. This will also help new factories start reliable, quality-controlled production. A current list of experienced filter technicians who can help set up factories and a list of factories that strive to apply best practice guidelines and accept visitors will be posted at [www.ceramicwaterfilter.org](http://www.ceramicwaterfilter.org) in the near future. It is also important to work with local potters who are familiar with the local clays and who will be employed at the filter factory on an ongoing basis.

The appropriate ratio of clay to burn-out material is determined empirically when the filter factory is established and will be specific to the characteristics of the materials used. The flow rate of finished filters is measured as an indicator of consistency of production and filter quality, both when determining filter mixture ratio and throughout production. Too much burn-out material can lead to fragile filters that do not adequately treat water and not enough burn-out leads to slow filtration rates. An appropriate filter mixture ratio, when other processes are carried out carefully, will produce filters that:

- 1) Press without tearing or slumping.
- 2) Dry without warping or cracking.
- 3) Fire without deforming or cracking.
- 4) Have sufficient strength once fired.

- 5) Have consistent and appropriate flow rates.
- 6) Pass microbiological testing.

The filter mixture ratio is not the only variable that influences the flow rate. Clay characteristics, the type and size of the burn-out material, the humidity of the burn-out material, amount of water included in the mixture, the type and particle size of additional materials included in the filter mixture, the method of shaping, the amount of pressure applied during pressing, the location of the filter in the kiln, and the firing profile and peak temperature reached will also influence the flow rate; therefore, the materials must be consistent and processes must be carried out carefully and consistently when producing prototype filters and during normal production. This will aid in achieving consistent results and increase the likelihood that filters that fall within the specified flow rate range are representative of the prototype filters that passed microbiological testing.

To determine the appropriate clay:burn-out ratio, batches of a minimum of ten filters are made from different clay:burn-out ratios. Depending on the local clay, initial trials should start with 50% dry, powdered, sieved clay and 50% dry, sieved burn-out, *by volume*. Generally, for sawdust, a ratio between 40:60 and 60:40 clay:burn-out by volume is an appropriate range (see Section 3.5, Figure 3-7 and Figure 3-8 for existing factory ratios). Once an equal volume of clay and burn-out is measured, they should be weighed to determine the relative proportions of each (approximately 5:1 clay to sawdust by weight). Materials for subsequent tests should be measured *by weight*. Measuring materials for production by weight is more accurate than by volume since low-density burn-out material can settle. Burn-out material is typically dried in the sun; however depending on the season and weather conditions, it can retain enough moisture from the atmosphere to affect its weight; therefore, factories should dehydrate the burn-out material before measuring it. This can be done in a pan over a small wood fire, in a drying oven, or by another dehydration method. If laterite, sand, or grog is added to the filter mixture, the amount of burn-out material required may need to be reduced, since these additives tend to increase the flow rate. Instructions for line and triaxial blending are provided in Annex D. It is important to label prototype filters and to thoroughly document materials characteristics, mixture ratios, and procedures so that suitable ratios and methods can be repeated.

Once dry materials have been mixed thoroughly, a measured amount of water is added gradually. Thirty percent (30%) water, by weight, is an appropriate amount to begin testing. The wet filter mixture should be moist, but on the dry end. It should feel a little drier than a typical cement mix or a typical clay mix for throwing on the wheel. Enough water has been added when the filter mixture can hold its shape when squeezed out through the hands or when it begins to compact into a ball. If the filter mixture is too wet, the pressed filter will “slump” or fall over when removed from the press. The amount of water added to the filter mixture might vary slightly depending on the climatic conditions and should be documented. Masks should be worn during mixing and anytime there is risk of inhaling silica dust or other airborne particles, as exposure can have serious long-term health consequences.

After pressing, drying, and firing the prototype filters, flow rates should be measured (Section 8.3.4) and the flow rate range for each ratio test batch should be evaluated and documented. Filters made from the mixture with flow rates closest to the target flow rate should be tested for

microbiological efficacy (Section 8.3.5). It is critically important that filters made from the selected mixture ratio consistently demonstrate microbiological efficacy in laboratory testing.

A minimum of three batches of ten filters must be manufactured with the proposed ratio and a minimum of three filters from each batch should be tested with contaminated water in a laboratory to ensure there is a minimum 99% (2-log) reduction in microbiological indicators. This is necessary to demonstrate that the results of the first successfully fired batch can be consistently repeated in normal production. If filters with both high and low flow rates are tested, the results can provide information regarding the flow rate limit. Effluent water from prototype filters should also be tested for heavy metals and inorganic chemicals to ensure the selected materials and processes do not contribute towards leaching contaminants into filtered water. Once a materials ratio has been established and verified, production can begin.

### 5.3 Filter Mixture Preparation

Raw materials selection and processing is discussed in Chapter 4. Filter mixture is prepared by mixing a measured amount of dry ingredients until homogeneous; water is then added gradually and the mixture is again mixed until a homogeneous consistency is achieved.

At Indo-2, dry materials are mixed manually for 1 hour as mixing for fewer than 50 minutes resulted in inconsistent flow rates.

The equipment needed for mixing these materials includes a measuring container for raw materials, a spring or other appropriate scale, a scraper, scoops, buckets, and a mixer. If electricity is available, a mortar mixer, which mixes horizontally with rotating blades, is recommended for this process. For best results, the mortar mixer should operate at 40-50 revolutions per minute (rpm). A cement mixer, in which the barrel rotates, is not recommended.

Each factory determines the mixture batch size according to the capacity of the mixer, daily production capacity, and kiln capacity. Filters manufactured from a batch of mixture should be kept together throughout production and fired in the same kiln load. It is important that the mixture ratio does not stray from the predetermined ratio. Burn-out material should be dehydrated (heated at a low temperature) to evaporate additional moisture before weighing it since atmospheric humidity can affect its weight. It is not known whether the storage of prepared filter mixture affects filter characteristics; therefore, it is recommended that filters be pressed on the same day that the filter mixture is prepared.

All dry raw materials, including processed clay and dehydrated processed burn-out material, as well as any additional materials such as laterite, grog, or sand, should be weighed and added to the mixer. Dry materials should be mixed together for a minimum of 10 minutes in a 40-50 rpm mortar mixer; if using a slower mixer, mixing time should be extended. Hand mixing is not recommended because of the difficulty of obtaining a homogeneous mixture; however, some factories do not have reliable or affordable electricity so mixing by hand is the only option. As an alternative to hand mixing dry materials, a drum mixer similar to those used in Myanmar (Figure 5-1), which does not require electricity, can be constructed locally. In every case, the goal is the even distribution of materials.

In Nigeria, where ingredients are mixed manually on the ground and then pounded in a mortar and pestle, the mixing process takes half a day.

When the mixture appears homogeneous, the measured amount of water should be added gradually to the mix. The water can be sprinkled into the mix by hand, with a watering can, or, as at some factories, with a custom designed automatic drip system. Although including silver in the filter mixture is not currently recommended (Section 7.6.2), if included, colloidal silver should be mixed with the water before adding it to the mixture both to reduce airborne silver particles and to promote consistent distribution. Once all the water has been added, the ingredients should be mixed for a minimum of 10 minutes and until a homogeneous mixture is achieved.

As each batch is mixed, the filter mixture should be visually inspected to confirm: 1) a homogeneous mix consistency; 2) no unmixed material remains at the edges or bottom of the mixing container; and, 3) the mixture has a similar appearance to other batches. The mixer should be checked that it is functioning properly and has not clogged.

For each batch of filter mixture, the following information should be documented: operator, date, mixer used, source of materials, weight of clay, weight of burn-out material, weight of additional materials included in the mixture, weight or volume of water, duration of dry mixing, duration of wet mixing, and visual or other observations (including weather, variation in materials, and variation in methods). The mixture batch should be referenced on filter logs so that details of mixture preparation for any given batch of filters can be referred to at a future date. A sample filter mixture log can be found in Annex G.



Figure 5-1: Drum Mixer  
(Thirst-Aid 2009)

Health and safety precautions for preparing filter mixture should include the use of face masks to protect employees from inhaling airborne particles and goggles to protect the eyes from dust. In addition, when using an electric mixer, long hair should be tied back and clothing should not be loose enough to get caught in the machinery. Clay dust can remain airborne for several hours, so facemasks should be worn even after mixing is finished and by employees in nearby areas where clay dust could also be airborne.



## 5.4 Wedging, Pounding, Kneading, Pug Mill

Before a filter is pressed, the filter mixture should be manually kneaded, wedged and/or thrust against the surface to remove air bubbles, reduce imperfections in the clay, and aid in aligning and compacting the clay particles, which can improve consistency and strength.

A scale is needed to weigh the filter mixture for pressing and a clean work surface is needed for wedging. If available, a pug mill (Figure 5-2) should be used before wedging the filter mixture.

Once mixing is complete, filter mixture can be processed through a pug mill, where available. This may improve the plasticity and strength of the filter mixture. The Myanmar factories started using (non de-airing) pug mills at all of their factories after finding that it resulted in much stronger filters. In Nigeria, the filter mixture is pounded in a mortar and pestle, which may also improve strength.

An appropriate weight of mixture for pressing (Section 5.8) should then be pounded, wedged, and shaped for pressing. Pounding and wedging should be carried out on a clean table or work surface that is a comfortable height, and workers should use the weight of their bodies and not just strength from their necks and shoulders while wedging.

## 5.5 Press

A press with a mold should be used to form the filter shape. It is difficult to produce consistent filters using manual methods, such as hand pressing or throwing on a potter's wheel. These methods should not be used unless manufacturing consistency and quality can be proven with microbiological testing at an independent laboratory.

There are a variety of styles of presses being used at different factories (Figure 5-3 through Figure 5-6). The main requirements for a press are these: 1) even pressure distribution; 2) a consistent amount of pressure; and, 3) an ergonomic design that is safe for employees.



Figure 5-2: Pug Mill (Thirst-Aid 2009)



Figure 5-3: Filter Press with Aluminum Mold, Indo-2 (Pelita 2009)



Figure 5-4: Filter Press with Cast-iron Mold, Cam-1 (IDECambodia 2009)



Figure 5-5: Filter Press with Wooden Mold, Myanmar (Thirst-Aid 2009)



Figure 5-6: Filter Press with Cement Mold, DR (FilterPure 2009)

Presses typically use an 8- to 32-ton capacity hydraulic jack. In selecting a jack, the design of the press should be taken into consideration. The PFP Dutch Press (Figure 5-7) is designed for a 20-ton capacity jack, and although a 32-ton capacity jack will work, make pressing easier and perhaps last longer, it could also increase the wear and tear on the press and cause it to break down. Jacks used for pressing oblong filters have an 8-ton capacity, and in Myanmar 10-ton capacity hydraulic cylinders are used.

Less effort may be needed to press filters if the jack is above the molds (Figure 5-5) applying pressure downwards, as opposed to the “jack-upward” press designs where the jack is located beneath the molds. Using a mechanized press further reduces the labor requirements; however, a mechanized press will need a stopping device to ensure consistent filter thickness and to prevent the mold from getting broken if too much pressure is applied.

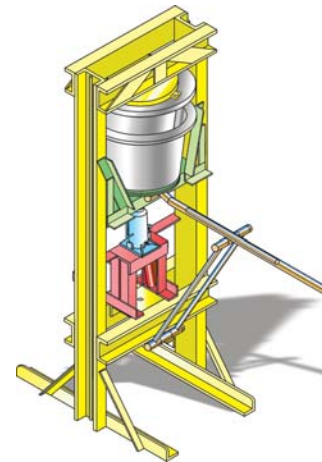

Figure 5-7: PFP Dutch Press

## 5.6 Mold

The mold determines the size and shape of the filtering element. Molds have been made out of cement, cast-iron, aluminum, and teak wood. In Myanmar, inexpensive molds carved from teak wood are used for making prototype filters. See Annex I for instructions on how to make a cement mold. The material the mold is made from will influence the type of mold release that can be used.

Currently three filter shapes are being manufactured: flat-bottomed (7- to 11-liter capacity), oblong (6-liter), and semispherical (10-liter) (Figure 3-9). A filter with a rounded wall may be stronger than one with a straight profile and it could discourage users from placing the round-bottomed filter on a dirty surface thus

SL-2 found that coconut oil did not work as a mold release with an aluminum mold but did with a cast-iron mold.

contaminating it, or from using it as something other than a filter, such as a flower pot or a stool. A shorter filter, with the same hydraulic conductivity, will have a slower flow rate due to a reduced hydraulic head. Larger filters take up more space in manufacturing and transport; however, since they have a greater surface area, they may accommodate a higher flow rate.

Regardless of the shape of the filter, the relationship between the filter element and the receptacle is important. There should be enough space below the bottom of the filter to store, at a minimum, the amount of water the filter holds (Section 9.2). The diameter of the filter rim is usually determined by the size of locally available receptacles. Filters should fit the receptacles closely both to ensure proper filtration and to prevent debris and insects from getting into the filtered water.

For flat-bottomed filters, the mold can be installed on the press either male above and female below, or female above and male below. Where round-bottomed filters are produced, the female mold is above and the male below as these filters can only rest on their rims.

Molds must be checked for proper alignment by cutting a freshly pressed filter lengthwise, in half and then quarters, with a piece of wire or fishing line. The wall and base thicknesses should be measured and compared at various heights with calipers (Figure 5-8 and Annex F). The mold should be aligned so that there is no variation in thickness either throughout the filter walls or the base of the filter.



Figure 5-8: Checking Mold Alignment (Rayner 2006)

## 5.7 Mold Release

Some form of mold release is required to prevent the filter mixture from sticking to the mold. Plastic bags are the most common form of mold release used by filter factories and can be used as a mold release with any type of mold material. Plastic bags typically leave crease marks on the pressed filters requiring additional surface finishing of the pressed filter. Oils, such as coconut or palm oil can also be used, although factories have reported varying success with different oils as mold releases, sometimes depending on the material the mold is made from. Filter factories should choose the mold release that works best for them, taking into consideration the material the mold is made from, effectiveness, cost of both materials and labor, and environmental impact.

## 5.8 Pressing

Since clay particles arrange themselves perpendicularly to the pressure applied, the amount and consistency of pressure will affect filter consistency and strength. Both the moisture content of the filter mixture and the amount of mixture placed in the mold will influence the amount of pressure required to get the molds to their stopping position. It is therefore important that filter mixture be of a consistent moisture content; that the same amount of mixture, by weight, is used to

Cam-1 is testing coconut, vegetable, and fish oil as alternative mold releases to plastic bags in order to reduce the need to smooth crease lines left on the filters by the plastic bags.

press each filter; and that the filter mixture is placed in the mold in a similar manner each time.

The quantity of filter mixture will depend on the size of the mold. Enough mixture should be used so that only a small, but consistent, amount of filter mixture squeezes out between the molds. The traditional PFP flowerpot-shaped filter, with a fired capacity of approximately 7-liters, pressed in a manual press with a 32-ton capacity truck jack, requires approximately 7.5–8 kilos (16 pounds) of mixture. Approximately 11-tons of force is used to press a flat-bottomed filter (Cohen 2010b).

At Indo-2, a by-product from the production of coconut cooking oil is used as a mold release. It is melted in a bucket and stays liquid all day; the oil is applied to the mold with a sponge.

The area of the factory used for shaping and pressing should be kept clean and free of debris. Trimmings that have fallen on the floor or excess material squeezed from the molds should not be incorporated into a filter. If the molds do not release easily after pressing, a rubber mallet can be used to separate the molds, but the filter should be discarded and a fresh amount of mixture should be used to press a fresh filter.

The freshly pressed filter element is very soft due to its high water content; therefore, when moving it from the press to the drying rack, it should be handled carefully to prevent deformation and warping. The method of removing the filter from the mold will vary depending on filter shape and press design. With PFP flat-bottomed filters, before removing a filter from the press, a flat piece of wood is placed on the rim to prevent it from distorting, while the bottom of the filter is supported by a metal disk. The press operator should touch only these two pieces, not the filter itself, when transferring the filter to the drying rack. Some factories place a ring tool around the rim while moving the filter to the drying rack to prevent distortion of the rim.

In Nigeria, they found that putting the filter mixture into the mold in one piece, rather than in pieces, helped with the uniformity of the filter structure.

## 5.9 Surface Finishing, Stamping, and Drying

As water evaporates from the filter, the clay particles move closer together, causing the filter to shrink. The finer the clay particle size, the more water there is between the pores, so the more the clay will shrink. Warping and cracking during drying is the result of stress caused by unequal shrinkage: when the surface dries more quickly than the interior of the filter walls or when one section of the filter dries more quickly than the other (Figure 5-9). Often cracks and warping caused by uneven drying do not show up until after the filter has been fired (Section 6.8.10). Nonplastic particles, such as sand or grog, reduce shrinkage and aid in even drying because they absorb less water than the surrounding clay, dry out more easily, and create channels that help moisture escape to the surface (Hamer and Hamer 2004). The amount and the absorbency of the burn-out material will also influence even drying and the amount of shrinkage.

Filters can take three days to three weeks to dry depending on the weather conditions. Filters should be monitored throughout the drying process to ensure they are drying evenly. Since drying filters slowly and evenly is particularly important, filters should be placed in an area with controllable conditions protected from wind, direct sun, and rain. Ideally, filters should be allowed to dry in a damp, humid room. If a damp room is not available, filters can be covered with plastic bags that are gradually removed, allowing for slow and even drying. Drying filters on shelves made of slats allows for better air circulation and more even drying. If filters dry too slowly, mold can develop and leave unattractive marks that do not fire out.

Indo-2 dries filters on rolling racks; when filters are nearly dry, the racks are moved closer to the kiln so the warmth from the kiln accelerates the drying process.

Once the clay particles are touching, although the clay is still wet, the majority of drying shrinkage has taken place. Potters refer to this as the “leather-hard” stage. At this stage, which is about halfway between wet and dry, filters can be moved and handled with less chance of distortion but will not be too dry to resist changes made to the surface. For these reasons, the “leather-hard” stage is the optimal time for surface finishing, as well as for the application of identifying stamps, although filters should still be handled carefully and as little as possible.



Figure 5-9: Uneven Drying (Source unknown)

Any surface finishing that may be required should be carried out when the filter is leather-hard to ensure the rim is strong and the surface is even. Wrinkles or crease marks left from the plastic bags used to separate the filter from the mold should be smoothed out as they could develop into full-fledged cracks during the firing. Small voids can be filled in with wet filter mixture. Some factories roughen up the outer surface of the filter with a hacksaw blade to counteract the compression caused by the smoothing.

The final step in surface finishing is to stamp each filter with a batch number, serial number, and logo. A simple numbering system is to have one batch equivalent to one firing, so all the filters in a kiln load will have the same batch number and a sequential serial number. Once a filter has been labeled with a batch and serial number it should be recorded in the production log along with the following information: mixture batch, date of pressing, weight of mixture put in press, date of surface finishing, plus additional observations including weather, drying conditions, and visual appearance. A sample form is included in Annex G.

Once surface finishing is complete, the filter is again left to dry gradually, although, at this point, slow drying is less critical. Potters can usually tell when clay is dry because it will get lighter in both weight and color, and wet clay is much colder to the touch. Dryness can also be measured by comparing the weight of a filter with the weight of a known dry filter. Filters that are dry or nearly dry should never be patched; if any defects are observed they should not be corrected, instead, the filter should be destroyed.

SL-2 has converted a large kiln into a drying room and warms it to 45°C for 2 days using leftover charcoal from previous firings.

Throughout the drying process, filters should be inspected visually for cracks, deformation, warping, holes, large pieces of burn-out material, and even wall thickness. Filters that do not pass visual inspection should be destroyed and the filter mixture should not be reused to make other filters, but rather, can be used to seal the kiln door or for nonfilter-making purposes.

Reason(s) for rejection and other observations should be recorded in the filter log.

In Nigeria, locally made convection ovens can dry filters in 2 hours; however filters are usually left to dry naturally.

Drying time can be a limiting factor in filter production and will be affected by the weather; therefore, production should be scheduled so that the facility can meet demand throughout different weather conditions. Because filters will take more time to dry during the rainy season, an increased number of drying racks may be necessary to maintain the rate of production. If there is sufficient storage and kiln capacity, production can be increased during the dry season. Although production capacity is not strictly a quality issue, rushed or incomplete drying can become a quality control issue.

Clay can be artificially dried successfully in traditional pottery production and some factories have experimented with artificially drying filters from a wet stage. This is not recommended since the internal pore structure of the filter may be affected if filters are dried too quickly. However, once filters reach the leather-hard stage, fans can be used to ventilate the workshop. Increasing air flow reduces humidity, which aids in drying. Fans should not blow air directly on the filters and should be cycled: on for 3-4 minutes and then off for 15-20 minutes. This allows water to migrate out of the drying filters and is less likely to cause cracking than constantly operating fans (Cohen 2010b).

Once filters are in the final stages of drying, they can be moved near to a kiln that is being fired, or even placed inside a warm kiln. Ideally, filters should be completely dry before firing. If this is not possible because of the climate, "close-to-dry" filters can be heated in a kiln to no more than 100°C for 4 or more hours. If the temperature remains below the boiling point of water, moisture will evaporate, not boil, out of the pores, thus drying the filters. Alternatively, the stacked kiln can be heated to 100°C the night before, closed up, and left overnight. The kiln walls should retain enough heat to dry the filters overnight.

## 5.10 Recommendations

Based on the knowledge summarized in the previous sections, the following recommendations are made to filter manufacturers by the Working Group:

- 1) Before a factory is established, the production manager should visit a fully functioning filter factory.
- 2) An experienced filter technician and local potters should be involved when setting up a factory and developing the mixture ratio.
- 3) The appropriate clay:burn-out ratio should be determined at project outset, and used consistently throughout production. If the ratio is changed, the filter efficacy must be confirmed.

- 4) To confirm clay:burn-out ratio, a minimum of 9 prototype filters from 3 different batches should be tested; these prototypes should achieve a 99% (2-log) reduction of microbiological indicators.
- 5) Effluent water from prototype filters should be tested for heavy metals and inorganic chemicals before starting production.
- 6) Raw materials should be measured by weight, not volume, and burn-out material should be dehydrated before weighing it for use in filter mixture.
- 7) A mortar mixer operating at 40-50 rpms is recommended.
- 8) Mixed dry materials should be inspected visually for even distribution of clay and burn-out before adding water. Wet filter mixture should also be inspected visually to confirm even mixing.
- 9) The filter mixture should be processed through a pug mill, if available. Filter mixture should be wedged or kneaded before pressing.
- 10) A standard weight of filter mixture should be used to press each filter.
- 11) Filters should be pressed the same day the filter mixture is prepared.
- 12) Filters manufactured from the same batch of filter mixture should be kept together throughout production and fired in the same kiln load.
- 13) A press with a high-quality mold should be used to press the filter into shape and, to prevent warping, the filter should be handled as little as possible after pressing.
- 14) Filters should be stored in conditions that allow for slow and even drying. They should be protected from direct sun, wind, and rain. Artificial drying from the wet stage is not recommended.
- 15) Once leather-hard, each filter should be stamped with a batch number, serial number, and logo. Surface finishing may be carried out at this stage.
- 16) A detailed production log should be maintained that documents the manufacturing process for each filter.
- 17) Filters should be inspected visually after pressing and periodically throughout the drying process for deformation, uneven drying, and cracks or holes.
- 18) Once beyond the leather-hard stage, filters should never be patched. Rejected filters should be destroyed and the mixture should not be reused to make filters.
- 19) Health and safety guidelines should be strictly enforced. Facemasks should be worn by anyone exposed to airborne particles.

## **5.11 Areas for Further Research**

The following areas require further research in order to refine recommendations for best practice in ceramic water filter production:

- 1) How does storing prepared filter mixture before pressing affect filter characteristics or performance? For example, does sawdust expand and thus increase pore size? Is plasticity increased?
- 2) What are the impacts on filter effectiveness, if any, of including dried, unfired filters that have been pulverized and screened in new batches of filter mixture? If this process is found to be acceptable, is there a maximum percentage of reprocessed material that can be safely introduced to the mixture batch without compromising filter effectiveness?
- 3) What is the acceptable range of clay:burn-out ratios for each of the various burn-out materials, taking into consideration the relationship between flow rate and microbiological effectiveness? How is the ratio affected by different clay characteristics?
- 4) Is there a visual indicator that can be added to the burn-out material to aid in evaluating thorough mixing but that does not impact filter effectiveness?
- 5) How does the size and shape of the filter element (rounded vs. flat bottomed shape, size variations such as diameter, depth, volume, and wall thickness) affect the strength, hydraulic properties, and biological effectiveness? Is there an optimal design for filter size and shape for different circumstances?
- 6) How do process variables such as hand vs. mechanical mixing, the amount of pressure applied during pressing, or the use of a pug mill affect pore structure and fired filter strength?

## **5.12 Chapter Details**

The information for this chapter was collated by Lisa Ballantine and expanded upon and edited by Justine Rayner. Two conference calls were held to discuss topics in this chapter.

Participants on the first call included: Mike, Justine, Daniele, Robert, Susan, Lisa, Tracy, and Vinka. Participants on the second call included: Burt, Robert, Mike, Lisa, Tracy, Justine, and Daniele.



## 6 Variables: Kilns and Firing

### 6.1 Introduction

This chapter contains information on kilns, fuel, monitoring and controlling temperature, firing theory, and concludes with recommendations for best practice and further research. Much of the information in this section is summarized and adapted from Manny's *Firing the Manny Kiln* (Hernandez 2007) and *The Potter's Dictionary of Materials and Techniques* (Hamer and Hamer 2004).

### 6.2 Types of Kilns

Kilns, whether fired by wood, oil or gas, have a firing chamber where the wares are stacked, entry ports for the fuel, an inlet flue to control the entry of air, exit flues, bag walls to deflect the flames from the wares, a chimney, and a damper system to control the draw of air and pressure within the kiln chamber. Any kiln should be housed under a shelter with sufficient overhang to prevent it from getting damp or wet as firing a wet kiln will take longer and use more fuel.

Updraft kilns have an opening in the roof where the heat exits. A moveable damper is placed over the opening to control the heat and pressure inside the kiln (Figure 6-1). In a downdraft kiln, the heat flows up inside the kiln but since there is no opening in the roof, it is forced down through the wares and exits through the flue opening in the kiln floor before it is drawn out through the chimney (Figure 6-2). Because of this "U" turn, the heat is used twice, and this makes a downdraft kiln more fuel efficient (Hernandez 2007). Downdraft kilns also tend to have more even heat distribution and more options for temperature and atmosphere control.

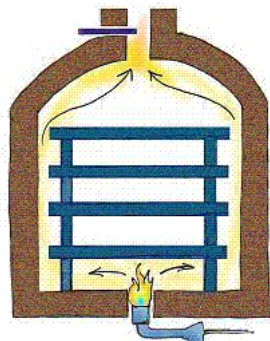

Figure 6-1: Heat Flow in an Updraft Kiln

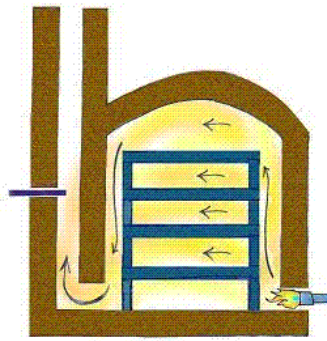

Figure 6-2: Heat Flow in a Downdraft Kiln

(Peterson 2009)

Firing efficiency, level of production, available space, and fuel source should be considered when selecting the design, size, and shape of kiln(s). A cube-shaped chamber allows for the most even distribution of heat because the roof and walls are equidistant from the center. Increasing the height will decrease even heat distribution and firing efficiency; however, kiln depth can be increased without reducing firing efficiency (Olsen 2001: 42).

Firing is often a limiting factor in production capacity because it takes 8 to 12 hours fire a kiln and 12 to 24 hours to cool it. Therefore, the size, shape, and number of kilns should be decided depending on available space and with the level of production in mind, considering

mixture batch size, daily production capacity, and factory storage capacity. A kiln with a 1.25 x 1.25 m (1.95 m<sup>3</sup> / 69 ft<sup>3</sup>) interior kiln space will hold approximately 60 filters and has about a 1.5 x 2.15 m (5 x 7 ft) footprint. Production can be smoothly coordinated if kiln capacity matches the number of filters that will be produced in 2 days or a multiple thereof. This allows production runs to be fired in one firing and allows time for the firing and cooling of the kiln.

### 6.3 Fuel Options and Storage

The three types of fuel used in filter production are firewood, oil, and propane. Agricultural by-products are an important alternative fuel source; although some factories have experimented firing with them, none of the factories that participated in the survey currently use agricultural by-products as a primary fuel source.

Cam-1 successfully fired kilns using rice husks and a blower system; however, kilns are fired with wood since it is readily available.

Wood for fueling kilns should be cut to approximately 50 cm (20 in) long, and thick wood should be separated from thin wood. Treated lumber should not be used as it might produce toxic fumes or leave residues in the filters. In Colombia, about 600 kg (1,320 lbs) of wood is used to fire 125 filters in an updraft kiln. At least one factory commented that firewood might not come from legal cutting (Rayner 2009). Both firewood and agricultural by-products should be kept dry as the firing will take longer and use more fuel if the fuel is wet. Covering wood or agricultural by-products with a plastic tarp will hold in moisture and prevent drying. If a plastic tarp must be used, it should be removed when the sun is out and replaced at night to protect the fuel from rain.

Cam-2 found that injected rice husks did not burn properly, produced a lot of ash, and the cost of electricity made it too expensive. Machines for making compressed fuel logs were not durable.

Electricity is required to fire with agricultural waste. Wood is used to start the firing and when the kiln is up to temperature an alternative fuel injector system blows the agricultural waste into the firebox. Agricultural waste should be dried in the sun, sieved, and stored in sacks. The alternative fuel injector and/or blower system should be kept under cover when not in use. Further experimentation with firing with agricultural waste to increase efficiency is needed.

In Kenya, they have had success shoveling waste corncobs into the firebox. Since they burn fast and create temperature spikes, they are used towards the end of the firing.

At the Benin factory, kilns are fired with oil. Oil and water are dripped onto a stepped metal plate which is placed at an angle in the firebox (Figure 6-3 and Figure 6-4). The angle of the metal plate is determined by the viscosity of the oil. A small fire is lit underneath to heat the metal plates. The oil, stored in a raised barrel, is dripped onto the top step of the metal plate and subsequently drips onto the lower steps. A container of water is

Thirst-Aid did not have success firing with rice husks; although they fired successfully with oil, it was too expensive.

also plumbed directly over the top metal plate and drips onto the top step. The water helps vaporize the oil to produce a flame. Both the oil and water systems have shut-off valves. Approximately 5 drops of water to one drop of oil is used.



Figure 6-3: Firing with Oil, Thailand (Thirst-Aid 2010)



Figure 6-4: Oil Plate, Thailand (Thirst-Aid 2010)

Of the factories that participated in the survey, only the Yemen factory fires exclusively with propane; however, interest in propane as a fuel source is growing. Recently established factories have had propane-fuelled kilns built and others have had their Mani kilns converted or are considering switching to propane as a fuel source (Chartrand 2010; Cohen 2010b). In some places, this is because the increasing scarcity of wood results in an increase in cost, and/or due to environmental regulations in urban areas. Firing with propane allows for better control of both atmosphere and temperature rise; however, further experimentation and experience is required before recommendations and guidelines can be provided for firing techniques and kiln design (for example, local production of pipefitting burners, tank sizes, methods for connecting tanks, gas pressure, etc.)

When firing with propane, the Yemen factory recommends using several smaller canisters which helps maintain pressure.

## 6.4 The Mani Kiln

The recommended kiln for filter production is the Mani kiln. It is a downdraft kiln (Section 6.2) designed specifically for filter production because existing smaller updraft kilns were found to be inefficient and did not have the capacity to fire a large number of filters. This larger capacity, more fuel-efficient kiln was designed using the following criteria: 1) simple design; 2) inexpensive construction; 3) fuel efficiency; 4) capability of using alternative fuels; and, 5) buildable using local labor and materials. Mani Flat Top or Mani Arch Top kilns are currently being used by 16 factories. Other designs may be used provided they fire evenly—with less than one cone differential in heat distribution (Annex F)—and produce consistent results.

Understanding the Mani kiln and its design should aid in successful firings. Listed below are some of the features that have been designed into the Mani kiln which potters and kiln masters should be aware of when firing the Mani kiln. Many of these features are applicable to other kiln designs.

### 6.4.1 Flat Top Design

The flat top design, inspired by the Minnesota Flat Top, is actually not flat but rather domed, with the center being at least one inch higher than the sides. The domed “flat-top” requires 23 cm long (9 in) angle iron corner braces with tie rods and can be built in less than half a day. However, because there is a structural limit to the distance that can be spanned with a domed roof, if a kiln interior larger than 1m<sup>3</sup> is required, an arched-top Mani kiln design should be used. Mani arch kilns can be designed to hold up to 200 filters; however, building an arched roof requires an elaborate form with angle iron on all four corners and tie rods to secure the walls from being pushed outward by the weight of the arch.



Figure 6-5: Flat Top Mani Kiln  
(Hernandez 2006)

### 6.4.2 Kiln Walls

Mani kilns are built out of common construction grade bricks that have been fired above 1,000°C (1,832°F), which is higher than the 850-900°C (1,560°-1,650°F) firing temperature of filters. Since kiln walls absorb a lot of heat before it is transferred to the wares, and Mani kilns are primarily used in hot climates, the kiln wall is just one brick 15 cm (6 in) thick. This thickness makes heating the kiln and the wares inside easier and faster.

### 6.4.3 Firebox

The firebox, which consists of the grate area and the ashpit, is the area where fuel and air are combined for combustion. The grate was incorporated into the Mani kiln after initial firings found that an accumulation of ash and embers in the firebox did not allow sufficient air to enter the firebox for combustion. By using metal rebar to divide the firebox horizontally, wood can be placed on the grate and the space below serves as an ash pit. With this configuration, ash can be removed and the embers spread without disturbing the burning wood. The rebar were designed to protrude 10-15 cm (4-6 in) on either side of each firebox so they could be removed and replaced easily. Over time, the rebar distorts from the heat and can be difficult to remove if it is not checked regularly and replaced when showing signs of wear. The third generation Mani kiln (3GMK) uses bricks for the grate that can be replaced easily if they break. For this reason, the floor and grate bricks are never mortared in place. The ash pit should be as big, or bigger, than the area above the grate.

In Kenya they found that temperature resistant steel, purchased or found in a scrap yard, make long lasting grates that do not warp easily under regular firing.

### 6.4.4 Bag Wall

Bag walls divide the combustion space from the chamber where filters are stacked and serve to direct heat upwards and deflect flame from direct contact with the wares. The original Mani kilns did not have bag walls. The 3GMKs have adjustable, perforated, stepped back, pyramid design bag walls in the rear corners of the kiln, in front of both fire ports. They are about one-third the height of the interior of the kiln. This design allows the flame entering the kiln to be dispersed both to the bottom of the kiln and upward for more even heat distribution.

### 6.4.5 Temperature Controls

The Mani kiln has three temperature controls. During the preheating and water smoking phase, the manually operated damper in the chimney should be pulled out to the full open position to allow the moisture to escape. During the firing process, it can be pushed in or pulled out to control the draft and pressure within the kiln.

The loose floor bricks over the firebox and the flue channels that run under the floor of the kiln chamber can be separated slightly to allow more heat through the kiln floor and to reduce the chance of cold spots. The bricks over the firebox, from about the middle of the kiln to the flame port, should be separated by about 0.6-1.25 cm (1/4-1/2 inch). The bricks closer to the flue opening should not be separated, as this will cause the heat to be sucked directly into the flue opening.

In addition, the bricks over the firebox and chimney flue can be put in an alternating rowlock (on their sides) and flat position (Figure 6-6). This allows heat from the kiln to get under and into filters stacked upside down.

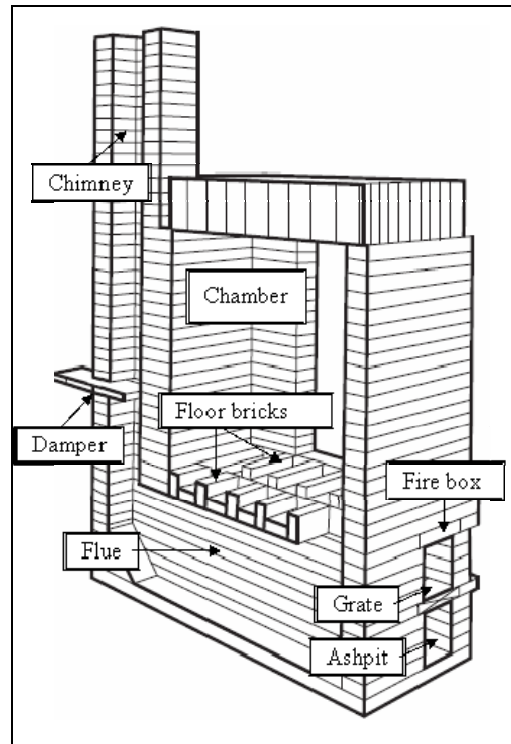

Figure 6-6: Mani Kiln Cross Section (Hernandez 2007)

## 6.5 Monitoring Heatwork and Temperature

### 6.5.1 Visually

Experienced kiln masters can estimate the temperature inside the kiln from about 600°C (1112°F) by observing the change in color of the wares during the firing (Annex B) through a spy hole in the kiln door. The spy hole is usually located in the upper half of the kiln wall to prevent cold air from entering when observing the cones. During the firing it is plugged with a piece of brick that should be removed with caution as hot air will escape. When looking inside the kiln at red to white hot temperatures, proper safety goggles that protect against ultraviolet and infrared light (for example, welder goggles) should be worn. Other visual cues, such as vapor or smoke emissions, can provide information that helps estimate the temperature and the phase of firing.

Although monitoring temperature visually can be reliable, it is recommended that cones and pyrometers with thermocouples be used to support visual estimates. Cones provide feedback on heatwork on the wares in the kiln and pyrometers provide specific information regarding the rate of temperature rise in different parts of the kiln. Pyrometers also assist in the identification of the firing stage, provide specific temperatures that can be charted on firing graphs for comparing firings, facilitate troubleshooting and research, and can aid in improving fuel efficiency.

## 6.5.2 Pyrometric Cones

Pyrometric cones are designed to measure heatwork, which represents the effects of time and temperature on the wares, rather than ambient temperature, which is measured by a pyrometer.

Cones are designed to “squat” or collapse at a specific temperature. The temperature the cone squats may vary slightly depending on the firing conditions such as heating rate, soak time, and atmosphere (oxidation vs. reduction). Cone numbers, which can vary across manufacturers, correlate with specific temperatures and range from low (022) to high (12+) temperatures. There are three types of cones: large, self-supporting, and small. Large and small cones need to be mounted in cone holders or a block of clay. Self supporting cones, as suggested by the name, have a base that supports them. Large cones should extend 2 or 1  $\frac{3}{4}$  inches (5.1 or 4.45 cm) above the mounting base. Small cones will bend at a slightly higher temperature and should have 15/16 of an inch (2.4 cm) exposed above the cone pack.

To give consistent feedback, the same types of cones should be used in each firing and they should be placed at the same angle, considered collapsed in the same position, and placed in the same locations in the kiln each time. Cones should be set at an 8° angle and considered collapsed when the tip is bent over and level with the base. Once a cone starts bending, it takes about 15-25 minutes to bend completely; it will bend slowly at first then faster once it has reached the halfway point (Orton 2001).

Three cones of different numbers should be placed in each cone block, which can be made from filter mixture. To avoid the chance of the cone block exploding, the block should be allowed to dry thoroughly before the firing. The three cone method (cones 012, 011, 010, for example) provides an indication of when different temperatures have been reached. The first cone, the guide cone, collapses as the desired temperature approaches. The second cone, the firing cone, melts when the desired temperature has been reached. The third cone, the guard cone, should not be allowed to melt, as this indicates that the desired temperature has been exceeded.

One cone block should be placed in view of the spy hole in the kiln door. The spy hole is blocked during most of the firing, but can be carefully opened for viewing wares and cones in the kiln. Caution must be used when opening the spy hole and when looking inside as the air coming out will be very hot. Appropriate safety goggles should be worn to protect against damage from ultraviolet and infrared light. An additional two cone blocks, with three cones in each, should be placed at different heights in the kiln to check for temperature variation within the kiln after the firing. If there is concern that the kiln is not firing evenly, more cone packs should be included. The heatwork achieved in different parts of the kiln can be established after the firing based on the deformation of the cones in each location (see Annex F-2).

Cones cannot be reused. Even cones that do not deform during a firing (including guard cones) cannot be reused since they have already been subjected to heatwork and thus will not

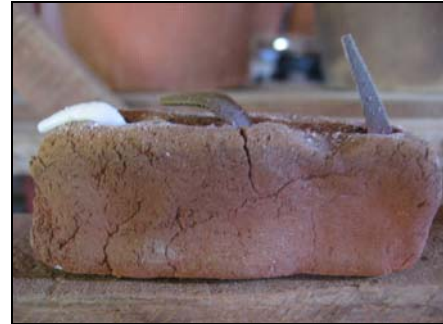

Figure 6-7: Cone Block  
(Rayner 2006)

provide an accurate result. If cones discolour during a firing, either the firing was too fast or there was heavy reduction (not enough oxygen) early in the firing. Readings from discoloured cones might not be accurate as they might have taken longer to deform. Brown cones (containing iron) are intended for use in fully oxidized firings; therefore, if the atmosphere is reduced they might deform early (Hamer and Hamer 2004: 77-79).

### 6.5.3 Pyrometer

A pyrometer with thermocouple(s) (Figure 6-8 and Figure 6-9) is used to measure the ambient temperature in the kiln, thus allowing the rate of temperature change during heating or cooling and the hold/soak temperatures to be monitored and documented. Although other cues, such as vapor or smoke emissions, can provide information to estimate the temperature, using a pyrometer with thermocouples can aid in identifying: 1) temperature variation in different parts of the kiln during firing; 2) temperature fluctuation during sensitive temperatures; and, 3) the rate of temperature change. Monitoring these parameters can aid in fuel efficiency, allow for more consistent and controlled firings, and lead to more consistent results.



Figure 6-8: Digital Pyrometer  
(Source unknown)



Figure 6-9: Protection Tube (top) and Thermocouple (bottom)  
(Source unknown)

Thermocouples can be inserted at different heights to measure the temperature in different parts of the kiln. Some thermocouples are manufactured to withstand the shock of being removed during the firing while others should be left in place throughout the firing. If the pyrometer has a dual-read function, two thermocouples can be connected to it and the reading can be switched between the two during the firing. We recommend that one thermocouple be inserted in the lower third of the kiln and one in the top third of the kiln (not on the side of the kiln where the wood is fed into the firebox) so that the temperature differential between the top and bottom of the kiln can be monitored. Information on pyrometer and thermocouple selection and sources is included in Annex J.

### 6.5.4 Draw Trials

Draw trials are used to confirm that sufficient time, temperature, and oxygen have allowed for the complete burn-out of carbon. They can be made from pieces of failed dry filters or from filter mixture to the same thickness as the filters, and should be included in each firing. Draw trials are placed in a position where they can be accessed during the firing (Figure 6-10). With a Mani kiln, where the flue entrance is right in front of the door, the trials should be placed about 40-50 cm (15-20 in) back from the wall as the draft from the gases exiting the kiln can prevent their oxidation and result in false positives (Cohen 2010b). When the desired firing temperature has been reached, a piece of re-bar can be used to carefully withdraw one trial

through the spy hole in the kiln door (Figure 6-11). The trial should be broken and the profile examined for a black carbon core (Figure 6-12). If the core is black, the firing should be held at temperature (soaked) and the process should be repeated with another draw trial, until a trial is withdrawn that has no evidence of a carbon core (Cohen 2010b).



Figure 6-10: Draw Trials and Cones in Stacked Kiln (Cohen 2010a)



Figure 6-11: Draw Trial Being Removed (Cohen 2010a)



Figure 6-12: Broken Draw Trial with Black Core (Cohen 2010a)

## 6.6 Firing Log

A firing log should be maintained for each firing. The log should include:

- 1) background information (kiln master, filter batch details, date, weather conditions);
- 2) the time the firing started;
- 3) temperature readings from each thermocouple at designated intervals;
- 4) the interpretation of visual cues at various stages (steam, smoke output, color of the filters);
- 5) temperature readings and time when cones fall;
- 6) time, temperature(s), and draw trial results;
- 7) the peak temperature reached;
- 8) soak time;
- 9) the time the firing stopped;
- 10) the temperature and time the door was opened; and,
- 11) additional cone pack locations and results.

Firing curves can be produced from the information recorded and can be used to visualize and compare firings (Figure 6-21). A sample firing log and a sample filter location log for recording each filter location within the kiln are provided in Annex G.

## 6.7 Combustion

Fuel, such as firewood, burns in two stages. When a new piece of wood is added to the fire, the wood first gives off volatile gases that burn. In wood, the volatile gases amount to about 80% of the total mass and the remainder is in the form of fixed charcoal. The flames of the fire



are these burning gases and they often do not touch the wood. After the volatile gases have escaped, only charcoal is left and it burns with gentle blue flames.

The main challenge is to ensure a good strong fire by balancing the air to fuel ratio. The greatest rate of temperature rise will be at the stoichiometric balance (ideal air-fuel ratio), which is when there is just enough air to combine with the carbon to burn all of the fuel allowing for complete combustion. If too little air is let in, a reduction atmosphere will be created and some of the volatile carbon gas will go out the chimney as black smoke, which translates into wasted fuel. A reduction atmosphere will also result in a stalled temperature rise and a darkened clay body. Too much air entering the kiln will have a cooling effect and more fuel will be needed to get to temperature.

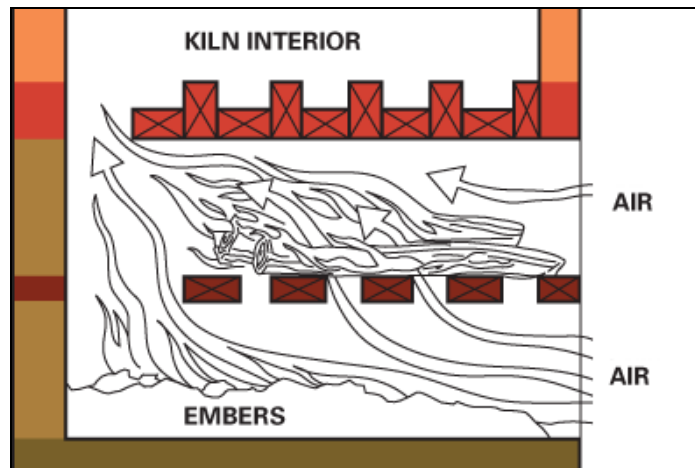

Figure 6-13: Cross Section of Ash Pit and Firebox  
(Adapted from Hernandez 2007)

For complete combustion, enough air needs to enter to burn the volatile gases being released from both the charcoal in the ash pit and the burning wood on the grate above. The grate in the firebox divides the air inlets so that air is drawn into the firebox both above and below the grate (Figure 6-13). The air that enters below the grate passes over the embers and promotes the burning of the volatile gases being released from the charcoal. If enough air has access, it will rise through the grate and help burn the gases being released from the burning wood on top of the grate. The preheating of this air increases thermal efficiency. Additional air entering above the wood on the grate also promotes the complete combustion of the gases released from the wood on the grate.

If enough air for complete combustion has access below the grate, firebox doors (Figure 6-14) can be installed to restrict additional air from entering above the grate. The doors are divided at the grate level, the upper door is closed throughout the firing, except when stoking. Air is forced to enter below the grate and is preheated by the coals. Firebox doors encourage a slower and more complete burn (Chartrand 2010). The damper in the chimney is used to control the amount of air drawn into the kiln by the chimney. When the damper is closed, pressure builds up in the chamber and less air is drawn in through the firebox.

More wood does not mean more heat. Too much wood on the grate will keep air from entering over the burning wood, preventing complete combustion. Wood should be spread out evenly on the grate so that air has easy access to it. The distance between the grates might vary slightly depending on the size of the fuel used, but typically it should be 15-20 cm (6-8 in) so that the wood will fall into the ash pit as soon as it is nearly burnt out. If there is not enough space between the grates, burnt wood will not fall through the grate and this will block air from entering. If there is too much space between the grates, big pieces of wood can fall through and may block air from entering below the grate. A thick layer of embers is needed in the ash pit to preheat the air entering below the grate; however, embers should not be allowed to pile up to the point where they prevent the flow of air. When raking out embers, a sufficient amount (5-10 cm / 2-4 in) must be left to preheat the air.

The density and size of the wood will influence the rate of heating and the heat distribution within the kiln. Soft woods, such as pine, are less dense and release their energy quickly. Smaller pieces of wood will have a quicker rate of combustion, resulting in more heat being released and will produce longer flames. Larger and thicker pieces of wood will combust more slowly, produce a shorter flame, and release less heat (Olsen 2001: 155). Therefore, thicker pieces of wood should be used in the early stages of firing and a combination of thick and thin pieces of wood should be used to raise the temperature towards the end of the firing. The Mani kiln typically fires cooler on the bottom; therefore, larger pieces of wood, which produce a short flame, can help keep the heat lower for a longer time (Olsen 2001).

## 6.8 The Firing Process

Clay passes through several stages during firing and it is important to follow a firing schedule so that certain processes are successfully completed. Due to the size and thickness of filters and the high proportion of burn-out material included in the filter mixture, the firing schedule for filters will differ from that of typical pottery.



Figure 6-14: Firebox Doors

Top: Sliding firebox doors; lower door raises (Chartrand 2011)

Bottom: Hinged firebox doors (Cohen 2010a)

The Nigeria factory found that normal firewood does not reach peak temperatures; therefore they fire with dense wood.

An experienced filter technician can be a valuable resource for learning to fire filters. Experience is key to successful firings and with time and experience kiln masters may develop their own firing style, as long as the key stages are carried out with success. In a successful firing, fewer than 10% of the filters should crack and there should be no evidence of a black core in the filter walls.

Veteran kiln masters may be able to fire filters in as few as 8 hours, but depending on the climate, material characteristics, and the humidity of the filters, most firings will take 10 or more hours. Cooling can take from 12-24 hours depending on the kiln size and climate. In general, it should take 1-4 hours to reach 150°C, so humidity can evaporate gradually from the filters; after 150°C, the temperature can be increased by 100°C per hour to 350°C. It is important to take two hours from 350° to 450°C, when the burn-out material is combusting. Once that phase is complete, the temperature can be raised by 100°C per hour up to 700°C. From 700°C to the peak temperature it can take 1-3 hours. Sufficient oxygen must be present during this phase to burn out the carbon. It may be necessary to hold the firing at peak temperature both to equalize the temperature distribution within the kiln and to ensure that the carbon fully burns out from within the filters. These stages are described in more detail in the following sections. The following graph (Figure 6-15) shows a theoretical firing curve with the stages of firing labeled. A graph from an actual firing is presented in Figure 6-21.

The first firing of a newly-constructed kiln will take longer than usual because the kiln will still be wet after construction. How the kiln reacts to factors such as outside temperature, wind, and the characteristics of the fuel can be adjusted for with the experience gained from the first few firings. New kilns should be mapped for temperature variation (Annex F).

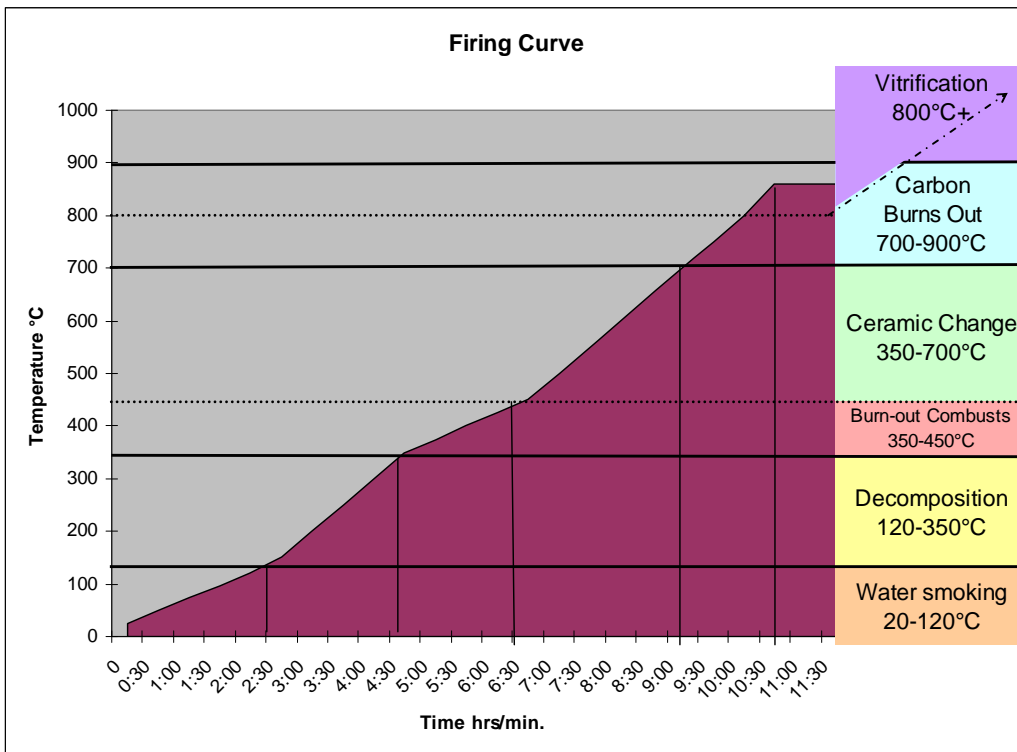

Figure 6-15: Firing Curve and Stages of Firing (Stages of firing adapted from Hamer and Hamer 2004: 139)

### 6.8.1 Stacking the Kiln

Before the kiln is stacked, it should be inspected for cracks in the walls, floor, and roof; bent firebox rods; damage to the wall at the end of the firebox; the roof losing its dome shape; and other defects. Employees should have access to materials and resources to carry out minor repairs to kilns. The bottom of the kiln floor should be as smooth and flat as possible. A layer of sand on the kiln floor will allow filters to move smoothly as they shrink and contract, thus reducing the chances of warping and cracking. Filters should be as dry as possible (Section 5.9) before stacking the kiln. The dryness of a filter can be determined by comparing its weight to that of a known dry filter. The kiln will fire more efficiently, and the heat will hold better and be more evenly distributed, if the kiln is loaded to capacity.



Figure 6-16: Flat Bottomed Filters Stacked in a Kiln (PotterswithoutBorders 2010)



Figure 6-17: Filters Stacked for Firing, Myanmar (Thirst-Aid 2009)



Figure 6-18: Oblong Filters Stacked for Firing (Hernandez 2010)

Filters may crack if they are subjected to stress caused by uneven heating or cooling. As the kiln is heated, the outside of the wares get hot before the heat diffuses to the center of the wares. The time required for this diffusion is proportional to the square of the thickness of the piece (Rado 1988). Since filters are thicker than typical pottery, additional time needs to be allowed to ensure filters heat and cool as evenly and thoroughly as possible. Similarly, stacked wares will take much longer to equalize in temperature than pieces placed separately (Rado 1988: 118). Therefore, spacers or clay wedges should be used between filters to improve heat and air circulation, reduce carbon marks on filters, and prevent warping.

Flat bottomed filters should be stacked end to end and mouth to mouth, with spacers between each filter. Filters should not be stacked more than five high because the filters on the bottom will not be able to support the weight of those above them (Figure 6-16). Round-bottomed, semispherical filters are stacked with spacers (Figure 6-17), and oblong filters are placed either horizontally in the kiln (Figure 6-18) or stacked using especially designed cylindrical clay spacers with cut notches (not shown) to minimize contact points between filters and resulting carbon marks.

At least three cone packs of three cones each should be placed at different heights in the kiln, with at least one within view of the spy hole. In addition, a series of draw trials should be placed in a location accessible from the spy hole but out of the draft of the gases exiting the

kiln (Sections 6.5.2 and 6.5.4). Filter locations should be recorded on a log either while loading or unloading the kiln. The log provided in Annex G, or a version modified to suit factory needs, should be used.

### **6.8.2 Water smoking (20°-120°C / 68°-248°F)**

During water smoking, the first stage of firing, the pore water (Section 5.9) remaining in the filters due to atmospheric humidity evaporates and turns to steam. If the temperature in the kiln rises too quickly, pressure will build inside the filter walls causing the filters to crack. It is therefore important to raise the temperature slowly up to the boiling temperature of water (100°C / 212°F).

Before starting the firing, the damper should be in the full open position, the spy hole should be unplugged, and the door should be built up except for the top three courses of bricks. To help dry the filters, especially in the rainy season, the kiln can be preheated to 100°C (212°F) and left overnight.

An initial fire, called a candling flame, should be started in the ash pit with a few larger pieces of firewood so that the firing begins slowly; this also helps building the layer of embers. It is necessary to continue the candling flame until all the moisture has evaporated from the kiln interior and the filters inside. Although in a typical pottery firing this could take fewer than 2 hours, due to the thickness of filters, and depending on the humidity of the filters, the kiln master should take a minimum of 2 hours, and possibly 4 or more hours, to reach 150°C (300°F).

When steam is no longer coming from the vents, the water smoking stage is complete. When wood or agricultural waste is used as a fuel, a mirror, piece of metal, or a cold, glazed surface can be held next to one of the vent openings to check for steam and vapor. A glove or some kind of protective cloth should be used since the air coming out of the opening will be hot. Since natural and liquid petroleum gas produce vapor as they burn, when using these fuels this method will require interpretation (Hamer and Hamer 2004).

### **6.8.3 Decomposition (120°-350°C / 248°-662°F)**

Once the water smoking stage is complete, it is then safe to raise the temperature more quickly. The fire, which is still on the firebox floor, can be stoked with 2-3 pieces of wood every 10-15 minutes; by using thin pieces of wood the temperature can be raised quickly but can be more easily controlled. Openings, except for the damper which is used to regulate the air entering the kiln, can be closed. Vapor will not come from the kiln vents during this stage.

The temperature can be raised from 120°C to 350°C at a rate of 100°C per hour, because although the filters will expand slightly during this phase, there is not much risk of cracking or breaking. At about 200°C (392°F), vegetable matter remaining in the clay breaks down.



Figure 6-19: Kiln being Fired, Cam-1 (IDECambodia 2009)

#### **6.8.4 Combustion of Burn-out Material (350°-450°C / 662°-842°F)**

Between 350°C and 450°C the volatiles in the burn-out material will vaporize and a lot of smoke will come out of the chimney. The temperature should be controlled so that it takes a minimum of 2 hours to transition through this phase, though the length of time required to successfully burn out the volatiles may vary slightly depending on the volatile-to-carbon ratio of the specific burn-out material used.

It can be difficult to control the kiln temperature during this stage since the combustion of the burn-out material produces additional heat; however, it is important to take this phase slowly because if the temperature is allowed to rise too quickly, it can result in cracked filters. The fires should be kept at the entrances to the fireboxes to help slow down the burn. If the temperature is more than 50°C cooler at the bottom of the kiln, in order to equalize the temperature, the passive damper (removable bricks in the chimney) should be opened completely and the active damper should be pushed in 25% since full chimney width isn't needed at this point. The carbon portion of the burn-out material will fire out later.

#### **6.8.5 Ceramic Change (350°-700°C / 662°-1,292°F)**

From about 450°C, or once the smoke from the combustion of the burn-out has eased off, the fire can then be moved from the floor of the firebox to the grates. The passive damper can be closed, the active damper opened, and the temperature can be raised by 100°C per hour to 700°C.

Between temperatures of 350°C and 700°C, the clay becomes ceramic. The chemically combined water will leave the filters, and again, water vapor will escape from the vents. From about 500°C, the stoking pattern and heat rise will become more predictable.

At around 573°C (1,022°F), the quartz in the clay rearranges itself; this is called the quartz inversion. It results in a sudden expansion during heating and sudden contraction during cooling. Because of this change in size, there is a risk of cracking, often referred to as dunting. Although the normal heating rate of 100°C per hour should accommodate this change, when passing through the temperature range of 550°-575°C (1022°-1067°F), this heating rate should be closely adhered to and a heat spike should be avoided. Effort should also be made to equalize the heat distribution in the kiln, especially if the kiln does not fire evenly. In the firing graph below (Figure 6-21), the top temperature is allowed to drop at this point to accomplish this equalization.

At around 600°C (1,110°F, dull red range), the clay particles are sintered together which results in very slight shrinkage. After 600°C, there is no danger of damaging filters by heat variations. From this point, the fire can be stoked with 4-6 pieces of wood every 15 minutes and the active damper should be kept completely open. Closing the passive damper will help with heat rise, though it may also increase heat variation within the kiln.

### 6.8.6 Burning-out (700°-900°C / 1,292°-1,652°F)

During this process, sometimes called oxidation, the carbon and sulfur in the clay are burned out. This process starts at 700°C, reaches its peak at around 800°C (1,472°F), and most of the carbon will have been burnt out by 900°C. During this phase, filters won't change in size. In order to ensure this process is thoroughly completed, sufficient oxygen should be present and the temperature should be held at around 800°C or 870°C for at least an hour and possibly up to 3 hours. If this stage is hurried or there is insufficient oxygen to oxidize the carbon, a black core consisting of carbon and/or black iron oxide, will remain in the filter walls. The amount of time required to achieve this may vary depending on the amount of carbon in the clay and in the burn-out material. In order to confirm that the carbon has successfully fired out, a draw trial should be carefully withdrawn through the spy hole in the kiln door, broken, and examined for the presence of a black core. If carbon remains, the temperature should be held (soak) and the process should be repeated until the black core has successfully been oxidized (Section 6.5.4).



Figure 6-20: Black Core  
Source unknown

Although two factories aim to leave a carbon lining in the filter wall, we do not recommend this until further research has been carried out on the effects of a carbon core on the microbiological effectiveness, the useful life of the filter, structural integrity, ideal thickness of the carbon core, and on the firing protocol needed to reliably achieve it.

### 6.8.7 Vitrification (800°C+ / 1,472°F+)

For most clays, vitrification starts at around 800°C. This is when the sodium and potassium oxides start to flux with the free silica. During this stage, the body contracts as the clay particles are welded together with glass, thus providing strength. The ideal level of vitrification will be a balance between the desired strength and the desired porosity of the final product. A minimum amount of strength; however, is needed to withstand the shock of the quartz inversion during cooling. The vitrification temperature will vary depending on the composition of the materials in the clay body, including clay minerals, non-clay minerals (fluxes), and the burn-out material. The vitrification range for earthenware clay is much narrower than for higher-fired clays, meaning it can easily be overfired.

From about 750°C until the end of the firing, the passive damper should be completely open. A layer of coals about 10 cm thick (4 in) should be maintained, and additional coal should be removed. The fireboxes should be stoked every 20-25 minutes, with wood kept near the entry of the fireboxes. A strong draft will pull heat through the kiln and the upper temperature will rise rapidly after each stoke. The upper and lower temperatures in the kiln will then start to even out; the top temperature will lower and the bottom temperature will rise 10°-20°C. The fireboxes should be filled again after the bottom temperature stabilizes. The temperature will rise consistently, but probably less than 100°C per hour. Care should be taken to not allow the top temperature to spike over the desired maximum temperature. When nearing the desired temperature, the top temperature should be kept fluctuating around the maximum temperature and the bottom temperature should be brought up to even the heat distribution in the kiln.

When the pyrometer reading nears the desired firing temperature, the peephole can be opened carefully to monitor the cones and the color of the filters. Appropriate safety goggles should be worn to protect eyes against damage caused by ultraviolet and infrared light. Since cones react to heatwork, they may deform before the pyrometer reading reaches the desired temperature. Only the first two cones (for example, 012 and 011) should be allowed to deform. The visual clue for this temperature (887°C or cone 012) in the kiln interior is a cherry red to red orange color (Annex B). A draw trial can be carefully removed and broken to check that the carbon has been fired-out successfully (Section 6.5.4).

When nearing the desired heatwork, the fire should be stoked with 4-6 short pieces of wood placed just inside the entry to the fireboxes about every 5-10 minutes. If the upper temperature drops below the lower temperature, wood can be added more often and pushed farther inside the fireboxes. Once the desired heatwork has taken place, the firing can stop. All coals and the remaining wood should be removed from the fireboxes. The firebox and the firebox openings can be closed off to allow the kiln

to cool slowly and to prevent cold drafts from entering the kiln as cold drafts can crack or warp filters near the flame port. The damper can also be closed to encourage slow cooling.

### 6.8.8 Cooling

During cooling, the clay contracts at a regular rate except during the quartz inversion (573°C / 1,063°F). The change in size, which occurs every time the quartz passes through its inversion point, can result in cracking due to stress caused by uneven contraction, which can be accentuated by variation in temperature. Therefore both firing and cooling should be gradual around 550°-575°C (1022°F-1067°F).

At temperatures above 1,100°C (2,012°F), quartz in clay converts to cristobalite. The cristobalite inversion occurs around 225°C (437°F). Once cristobalite has formed, the temperature change during both heating and cooling should be gradual to prevent cracking caused by the change in size during the cristobalite inversion. Since filters are typically not fired to this high of a temperature, it is unlikely that a significant amount of quartz will convert to cristobalite, and there will be little risk of crystal change each time this temperature is passed (Cuff 1996: 93).

Kilns should be left to cool for 12-24 hours, depending on the size of the kiln and weather conditions. Once the internal kiln temperature is at about 100°C, the kiln door can be opened.

Another method of controlling the upper and lower temperatures in the kiln involves removing one of the bricks covering each of the fireboxes. This creates a gap between the firebox and kiln chamber. Because some of the filters on the floor above the firebox come into direct contact with the flame, it can cause them to become over-fired and unusable. However, this technique is less labor intensive than the one described throughout this chapter.

Altering the position of the fire in the fireboxes also affects the upper or lower temperature in the kiln. In order to raise the bottom temperature in the kiln, the fire is moved to the outer edges of the fireboxes and the passive damper is opened. This causes the fire to rise vertically into the wares chamber, causing the bottom temperature to rise and the top temperature to lower. To raise the top temperature, the fire is moved towards the chamber entries and the passive damper should be closed somewhat (Chartrand 2010).



Handling hot filters should be avoided to prevent burns, or heat resistant gloves should be worn. If filter locations were not recorded during the loading of the kiln, they should be recorded while unloading the kiln. Each filter should be inspected and descriptions of cracks, deformation, discoloration, or other important observations, should be noted on the filter log. This may also be a good time to carry out auditory testing (Section 8.3.2) and record results.

Section 6.8.9 contains a description and firing graph of an actual firing. It provides helpful advice for evening out the heat distribution in a Mani kiln by monitoring both upper and lower temperatures in the kiln, using a pyrometer with two thermocouples, and adjusting the fuel stoking pattern accordingly. It also demonstrates how firing graphs can be used to visualize and interpret firings.

### 6.8.9 Equalizing Temperature Differential in a Wood-Fired Kiln, by Robert Pillers

Mani kilns typically fire hot on top; therefore, using two thermocouples can help monitor the temperatures in both the top and bottom of the kiln (Section 6.5.3). If both thermocouples are connected to a pyrometer with a dual-read feature, readings can alternate between thermocouples during the firing. By adjusting the stoking rate and the damper accordingly, the temperature differential can be reduced.

When the fire is stoked, the temperature in the top of the kiln will rise quickly yet the bottom temperature will remain steady. As more oxygen enters, and as the wood burns, the top temperature will level out and the bottom temperature will begin to rise. Although the inclination is to stoke the fire when the top temperature begins to decrease, stoking then will actually increase the temperature differential between the top and bottom of the kiln by causing the top to rise faster than the bottom. If patience is exercised by not stoking when the top temperature starts to decrease, the bottom temperature will continue to get hotter due to more oxygen and, although the top actually gets cooler, the two will gradually begin to approach equilibrium, although they may not meet at exactly the same temperature.

The next stoke should be when the rate of climb of the bottom temperature levels out, just before it begins to cool. The process will repeat itself and the firing graph will show a series of ups and downs of the top temperature of the kiln, representing each stoke, while the bottom temperature of the kiln will climb with a uniform upward curve.

In the firing graph below (Figure 6-21) thermocouple readings from an 11-hour firing in San Mateo Ixtatán, Guatemala, show that after 6:15, the top temperature (black line) fluctuates; the valleys match each stoke. The middle line (pink) shows that the bottom temperature rises quite evenly. The bottom line (yellow) represents the temperature differential between the top and bottom of the kiln. The temperature differential stayed below 100°C and gradually decreased; at the end of the firing, when cone 010 fell, there was just a 19°C temperature difference between the top and bottom of the kiln. The middle line (pink) follows the theoretical model in Figure 6-15 very closely!

Although this method will result in the most efficient (minimum) use of fuel as well as the most even heat distribution inside the kiln, in practice, it takes a great deal of discipline to fire this way.

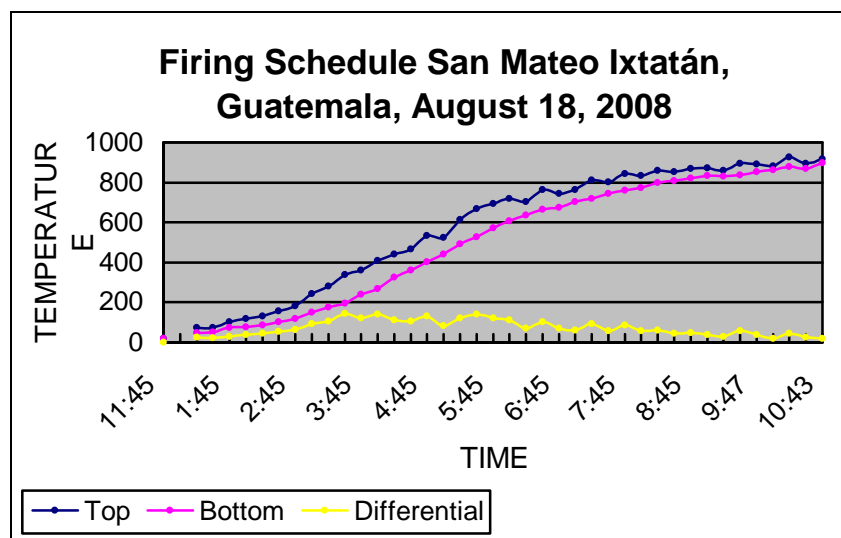

Figure 6-21: Firing Graph, San Mateo Ixtatán, Guatemala (Guate-2)

### 6.8.10 Cracking

Cracks appear when stress caused by the expansion, contraction, or shrinkage is greater than the clay body can absorb. Variation in materials or filter mixture, inconsistent thickness of filter walls or filter base, uneven drying, excessive weight on lower filters in the kiln, uneven pressure on rims, and firing temperature and firing cycle can all contribute towards the forming of cracks. Obvious cracks can form during drying; however, some cracks that open during firing may actually have formed during drying, but were not noticed. Upon close inspection of unfired filters, drying cracks can sometimes be identified. Cracks in filters are often caused by firing too fast during the combustion of the burn-out material as the filters are heated from both the inside and out (Chartrand 2010). Uneven wall thickness will also make filters vulnerable to both drying and firing cracks (Cohen 2010b). Uneven wall thickness is due to mold misalignment or poor mold design and can be diagnosed by examining the cross section of freshly pressed or fired filters (Section 5.5 and Annex F). It can be difficult to identify and correct the causes of some cracks. Detailed documentation of production may assist with this.



Figure 6-22: Cracked Filters

Top: Somaliland (Wagoner 2010), Nicaragua (Rayner 2006), Nicaragua (Rayner 2006).  
Bottom: Myanmar (Thirst-Aid 2010), Somaliland (Wagoner 2010), Nicaragua (Donachy 2010).

The widest part of the crack is the point where the crack started and the width of the crack indicates the amount of stress. Cracks in the rim are usually caused by stresses like uneven drying in the raw stage. Frayed edges and rough faces on the two sides of the crack show that the crack formed slowly and probably at the making and drying stages, even though it might have shown up after the firing (Hamer and Hamer 2004). Variation in color on the inside of the

crack compared with the surface of the filter can also indicate the phase at which the crack occurred. If the color is consistent throughout, it is likely that the crack opened during the early stages of firing, whether caused by uneven drying or heating the kiln too quickly. If the crack formed in the heating phase, there may also be some distortion.

A crack that shows variation in color will likely have formed during cooling. If one part of the filter cools before the other, different parts of the filter may contract at different times causing displacement in addition to the crack. These cracks often start at the rim, run downwards, and curve toward the cooler side. Uniform cooling and preventing drafts in the kiln at temperatures below 600°C (1112°F) can help prevent these cracks (Hamer and Hamer 2004).

Hairline cracks that are both concentric and vertical (Figure 6-23) also may be due to uneven cooling. Using spacers between filters, having an even wall thickness, and cooling slowly past the inversion temperature can help prevent these cracks. The peak temperature must also get hot enough for the clay to gain enough strength in the vitrification stage to withstand the inversion (sudden contraction) during cooling. This can be achieved by: 1) firing to a slightly higher peak temperature; 2) slowing the rate of cooling (maximum 100°C per hour from 600°C / 212°F per hour from 1112°F); 3) reducing the amount of free silica in the clay (quartz, flint, sand, or cristobalite); or, 4) increasing the flux (see 4.2.7) in the clay body to lower the temperature needed to reach maturation (Hamer and Hamer 2004).



Figure 6-23: Firing/Cooling Crack (Pelita 2009)

In addition to comparing the characteristics of cracks, analyzing production logs—including materials evaluations, production details, firing, and filter placement logs—can help identify patterns and diagnose possible causes of cracks.

## 6.9 Recommendations

Based on the knowledge summarized in the previous sections, the following recommendations are made to filter manufacturers by the Working Group:

- 1) Kiln capacity should be tailored to the proposed level of production and take into consideration mixture batch size, daily production capacity, and factory storage capacity. Production can be smoothly coordinated if kiln capacity matches the number of filters that will be produced in 2 days, so that production runs can be fired in one firing and time is allowed for the firing and cooling of the kiln(s).
- 2) Mani kilns are recommended, but other fuel efficient, reliable kilns that fire evenly and produce consistent results may be used.
- 3) Kiln temperature mapping should be carried out on a new kiln, annually, or if firing results (filter quality) are inconsistent.

- 4) Filters should be dry before being fired and should be stacked using clay spacers to promote heat circulation and even heating and cooling. This reduces the chances of warping, cracking, and carbon marks.
- 5) The firing temperature and firing curve appropriate for local clay and burn-out material should be established and followed, and a firing log should be maintained.
- 6) The location of each filter should be recorded on a log either while stacking or while unloading the kiln.
- 7) Firing should be slow and closely monitored during the critical phases of water smoking, combustion of the burn-out, and burning out of carbon to ensure that these processes are properly carried out. A black core should not remain within filter walls, and fewer than 10% of filters should crack per firing.
- 8) Kiln temperature and heatwork should be monitored visually and with pyrometric cones (three cone method), draw trials, and a pyrometer with thermocouples. The use of these methods will help monitor heat distribution in the kiln, aid in consistent firings and provide information to document and compare firings, aid in troubleshooting, and help increase fuel efficiency.
- 9) Fired filters should undergo visual and auditory inspections when unloading the kiln and observations should be recorded.
- 10) Efforts should be made to acquire fuel from sustainable sources and experimentation with the use of agricultural waste or alternative fuel sources is encouraged.
- 11) Health and safety precautions, especially the use of appropriate safety goggles when looking into the kiln at red to white hot temperatures, should be enforced.

## **6.10 Areas for Further Research**

The following areas require further research in order to refine recommendations for best practice in ceramic water filter production:

- 1) What are the effects of different mold releases on the firing process; do they influence the heating or leave a residue on the finished filter?
- 2) Does heating schedule or peak temperature affect arsenic or other inorganic materials or heavy metals in finished filters? Does fuel contribute to arsenic leaching from filters?
- 3) How does the firing profile affect complete combustion of different burn-out materials?
- 4) How does leaving a black core in filters affect filter efficacy and filter lifespan, and can the thickness of the black core be monitored or controlled?
- 5) What are ways to improve efficiency and cost of firing with alternative fuels? Is there potential for a low-cost system for recycling energy from heat exiting the chimney?

## **6.11 Chapter Details**

The information for this chapter was collated by Manny Hernandez and expanded upon and edited by Justine Rayner. Additional support was provided by Peter Chartrand, Robert Pillers,

Burt Cohen, and Barbara Donachy. Participants on this conference call to discuss this chapter included: Bill Austin, Bob, Manny, Tracy, Daniele, Mike, Justine, Robert, and Vinka.

## 7 Variables: Silver Nanoparticles (Colloidal Silver)

In this chapter, information about silver is reviewed, beginning with an introduction to silver nanoparticles (colloidal silver) and how disinfection occurs, followed by a discussion on differences between ionic silver and silver nanoparticles, how silver nanoparticles are produced, and the use of silver nanoparticles in ceramic filters. The chapter concludes with information on environmental and health concerns, silver dilution and application guidelines, and a summary of recommendations and areas where further research is needed.

### 7.1 Introduction

Silver and its compounds have been used for disinfection since the age of the ancient Egyptians when silver vessels were used to preserve water and wine (Russell and Russell 1995). Before the emergence of antibiotics, silver compounds were widely used during World War I to prevent infections in wounds. Metallic silver was also used to treat surgical prostheses and splints, and it served as a fungicide. Soluble silver compounds were used to treat a range of diseases from mental illness to gonorrhea (Drake and Hazelwood 2005). Even today, silver sulfadiazine is the standard antibacterial treatment for serious burns (Chen and Schluesener 2008). Recent advances in nanotechnology have demonstrated that nanosize particles of metallic silver have strong antimicrobial properties.

The two types of silver compounds used to impregnate ceramic filters are silver nanoparticles and ionic silver. Silver nanoparticles are also referred to as colloidal silver or nanosilver. Silver nanoparticles are obtained under controlled conditions using a variety of methods, which are presented later in this chapter. Silver nanoparticles can be suspended in water, and usually the resulting solution is grey-brownish in color. Ionic silver is obtained by dissolving a silver salt, such as silver nitrate, in water. The resulting solution consists of water and single atom silver ions (dissolved silver), contains no silver particles, and is transparent.

A silver nanoparticle is a fine particle of metallic silver that has at least one dimension lower than 100 nanometers (or 0.1 millionth of a meter). Nanosilver particles exhibit physical properties that are different from both the silver ion and the bulk material. Several studies have shown that silver nanoparticles have strong antibacterial properties and could be used in biomedical and environmental applications, such as for the treatment of wounds and burns (Furno *et al.* 2004; Maneerung *et al.* 2007) and for water disinfection (LePape *et al.* 2004; Jain and Pradeep 2005).

Silver nanoparticles have large surface areas and high reactivity compared with the bulk solid; thus, they exhibit remarkable physical, chemical, and biological properties. These properties may include a greater number of strained and dangling bonds, an increased surface free energy relative to the bulk cohesive energy (which means the particle may change phase more easily), and an increase in solubility (Morones *et al.* 2005). This knowledge has led to an increase in interest in using nanosilver as a special class of biocidal agents. Sondi (2004) showed that silver nanoparticles are an effective bactericide against *E. coli*. Other recent studies have demonstrated the antimicrobial properties of silver nanoparticles against other pathogenic microorganisms such as *Bacillus subtilis* (Ruparelia *et al.* 2008), *Staphylococcus aureus* (Dubas *et al.* 2006), *Staphylococcus epidermidis* (Panacek *et al.* 2006), and HIV-1 (Elechiguerra *et al.* 2005). Researchers have investigated the bactericidal properties of silver

nanoparticles supported by a wide variety of materials, such as polyurethane foam (Jain and Pradeep 2005), zeolite (Rivera-Garza *et al.* 2000), alumina (Heinig 1993), activated carbon (LePape *et al.* 2002; LePape *et al.* 2004), textiles (Dubas *et al.* 2006), and ceramic materials (Oyanedel-Craver and Smith 2008).

In April 2005, a partnership between the Woodrow Wilson International Center for Scholars and the Pew Charitable Trusts established The Project on Emerging Nanotechnologies. The Project, which is located in 21 countries, maintains an extensive consumer product inventory of more than 800 products produced by 420 companies. It is dedicated to helping ensure that as nanotechnologies advance, possible risks are minimized, public and consumer engagement remains strong, and the potential benefits of these new technologies are realized. Silver nanoparticles, the active component of more than 20% of the nanoproducts currently available on the market, are the most commonly cited nanomaterial (Scholars 2008). Products that contain silver nanoparticles range from dietary supplements, to spray-on disinfectants, to anti-odor textile applications (Figure 7-1) and approximately 88% of these products have demonstrated some form of antibacterial or antimicrobial activity (Fauss 2008).

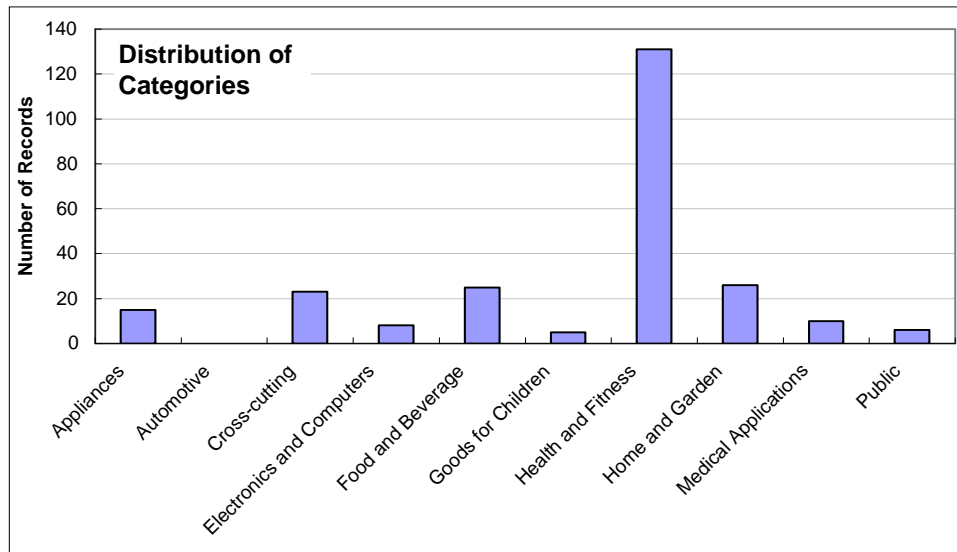

Figure 7-1: Commercial Silver Nanoparticle Products by Category (Fauss 2008)

## 7.2 Overview of Proposed Disinfectant Mechanisms of Silver Nanoparticles

Mechanisms that have been commonly accepted as explanations for how silver nanoparticles act as a disinfectant include: 1) interaction with the cell membrane; 2) silver ion release; and, 3) generation of reactive oxygen species (ROS).

### 7.2.1 Interaction with the Cell Membrane

Several studies have presented data suggesting that silver nanoparticles may interact directly with the cell membrane to inactivate the cells (Cho *et al.* 2005; Panacek *et al.* 2006; Pal *et al.* 2007; Shrivastava *et al.* 2007). In addition, using images produced with a scanning tunneling electron microscope and an X-ray energy dispersive spectrometer, it has been shown that



silver nanoparticles not only attach to the surface of the cell membrane (see Figure 7-2), but also trespass it (Lok *et al.* 2007). They suggested that silver nanoparticles penetrate inside bacterium and cause damage by interacting with phosphorus- and sulfur-containing compounds. This mechanism implies that physical contact between nanoparticles and bacterial membranes is essential for the disinfection process. Additional studies using different sizes of silver nanoparticles showed that smaller particles are more efficient at inactivating *E. coli* than larger particles (Lok *et al.* 2007).

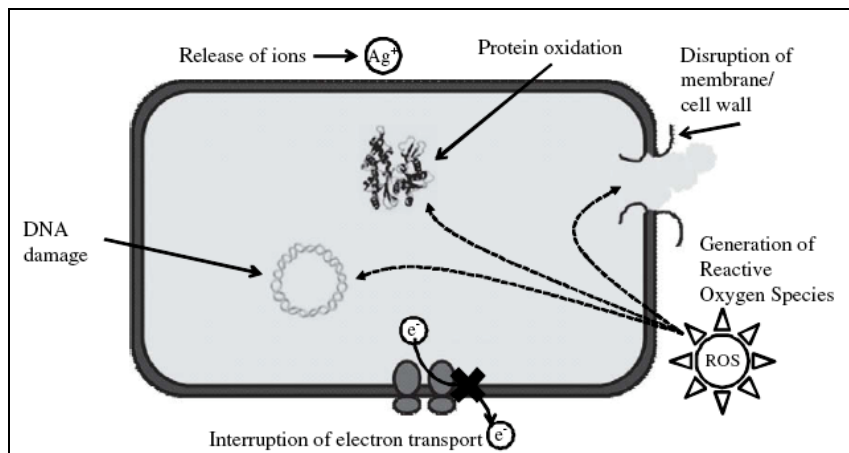

Figure 7-2: Proposed Antibacterial Mechanism of Colloidal Silver (Li. Q. 2008)

The cell-nanoparticle interaction will depend on the net surface charge of both particles (the cell and nanoparticles). Gram-negative bacteria, such as *E. coli* and other waterborne disease-causing organisms, typically have a negatively charged surface at neutral conditions because of the carboxylic groups in their outer membranes (Raffi *et al.* 2008). The surface charge of silver nanoparticles depends on the surface coating of the particle. The reported zeta potentials (indicative of surface charge) for silver nanoparticles varied from -30mV for “naked” silver nanoparticles (Merga *et al.* 2007) to +49mV for particles stabilized with cetyltrimethylammonium bromide (Soukupova *et al.* 2008). It is likely that positively charged nanoparticles experience the greatest electrostatic attraction to negatively charged bacterial surfaces.

The zeta potential value of the nanoparticle surface is also used as an indicator of the stability of colloidal suspension. Higher absolute values (either positive or negative) promote a stable suspension, whereas values closer to zero imply aggregation (an increase in particle size) and possible precipitation of the particles, which could potentially decrease the antibacterial properties.

The net surface charge will also be affected by the pH and ionic strength of the liquid solution. If the cell-nanoparticle interaction mechanism is responsible for the disinfection properties of silver nanoparticles, then dissolved and particulate compounds in the water could have an important influence on the effectiveness of the disinfection process. The concentration of dissolved inorganic compounds (such as carbonates, sulfates, and phosphates commonly present in natural water) determines the ionic strength, and therefore the zeta potential, of both the cell membrane and the nanoparticle surfaces. Also, dissolved organic compounds (such as

humic and fulvic acids) could be sorbed onto the surfaces of silver nanoparticles, thus changing their surface properties.

Of the three mechanisms proposed, the cell-nanoparticle interaction is the one most commonly invoked to explain the antibacterial properties of silver nanoparticles. However, studies using immobilized silver nanoparticles on different surfaces and matrices have also shown a considerable antibacterial effect (Rivera-Garza *et al.* 2000; LePape *et al.* 2002; LePape *et al.* 2004; Jain and Pradeep 2005; Dubas *et al.* 2006; Oyanedel-Craver and Smith 2008). Specifically, a recent study showed that the impregnation of ceramic water filters with a silver nanoparticle solution increased *E. coli* removal (Oyanedel-Craver and Smith 2008). Additionally, these studies suggest that direct cell-nanoparticle interaction could be responsible (or partially responsible) for the biocidal properties of silver nanoparticles.

### **7.2.2 Silver Ion Release**

Other studies have suggested that silver nanoparticle disinfection is caused by the oxidation of the silver nanoparticles and the subsequent release of silver ions. It has been suggested that silver ions released from silver nanoparticles penetrate the cell membrane (LePape *et al.* 2002; Furno *et al.* 2004; Maneerung *et al.* 2007) and either react with the thiol group in vital enzymes to inactivate them (Liau *et al.* 1997) or with DNA (Feng *et al.* 2000) resulting in marked enhancement of pyrimidine dimerization by photodynamic reaction, and possibly preventing DNA replication. This mechanism does not require a physical cell-nanoparticle interaction; however, it requires the oxidation of silver atoms on the surfaces of the nanoparticles and their release from the solid nucleus. It is well known that silver nanoparticles are highly sensitive to oxidation (Heinig 1993), so the concentration of dissolved oxygen in water may control this reaction.

The surface areas of nanoparticles will likely affect the rate of silver-ion release. Smaller particles have higher specific surface areas than larger particles and therefore, a larger area available for silver oxidation. The ionic strength of the water used to prepare the nanoparticle solution as well as the water to be treated will influence this process. High concentrations of dissolved ions will promote the aggregation of silver nanoparticles (reduction of the particle zeta potential), reducing the surface area available for Ag<sup>0</sup> oxidation and the release of silver ions. Although silver ions have been detected in solution either by direct measurement (Maneerung *et al.* 2007) or through the use of scavengers (LePape *et al.* 2002), other authors suggest that the amount of silver ions released from silver nanoparticles is not high enough to deactivate pathogenic microorganisms (Lok *et al.* 2007; Petica *et al.* 2008).

### **7.2.3 Generation of Reactive Oxygen Species**

The last mechanism proposed for silver efficacy was suggested by Heinig (1993), who observed that the bactericidal properties of silver-treated alumina increased when the dissolved oxygen concentration in influent water was increased from 3.2 to 8.5 mg/L. He suggested that silver had a catalytic effect that promoted the oxidation of bacteria and viruses. In studies of the interaction of oxygen and silver clusters, it was found that at temperatures between 77 and 105 Kelvin (K) (the Kelvin scale starts at a theoretical absolute zero which is 273.15°C below the freezing temperature of water) molecular oxygen chemisorbed to the silver particles (Schmidt *et al.* 2003). At temperatures greater than 105 K, chemisorption was

transformed into oxidation, invoking the dissociation of oxygen molecules and the release of highly reactive oxygen atoms (with a  $-2$  oxidation state). This phenomenon was reported in an electron spin resonance spectroscopy study of silver nanoparticles; Danilczuk *et al.* (2006) reported Ag-generated ROS, such as free radicals.

Few studies have been performed to support Heinig's hypothesis. It has been observed that the addition of superoxide dismutase (the enzyme that catalyses the dismutation of  $O_2^-$  to  $O_2$  and  $H_2O_2$ ) reduces damage in *E. coli* cell membranes (LePape *et al.* 2004; Kim *et al.* 2007), thereby proving that ROS compounds participate in the disinfection process with nanoparticles. These experiments did not determine the amount of superoxide produced or the presence of other ROS. Similar to the release of silver ions, the production of ROS depends on the surface area of the particle and the dissolved oxygen concentration in the water. Dissolved organic matter may compete with bacteria for oxidation and, specifically, humic compounds could act as scavengers of ROS because of their large aromatic structures, reducing the amount of ROS available to deactivate bacteria. ROS can contribute to the inactivation of pathogenic organisms other than bacteria and because of the high reactivity of ROS, these compounds could be more effective than chlorine in disinfecting spore- or oocyst-forming organisms such as *Cryptosporidium parvum* (Jeong *et al.* 2006).

#### **7.2.4 Summary**

Although it is clear that nanoparticle silver is effective at inactivating bacteria, the exact mechanism is unclear. The majority of the studies have been performed under different conditions, which makes comparison difficult. In many cases, mechanistic considerations were not the primary focus of the investigation. None of the studies previously discussed determined the optimum conditions for the application of silver nanoparticles as antimicrobial agents in water treatment. It is very likely that the disinfectant action of silver nanoparticles will depend on the properties of each microorganism and the water chemistry in which the disinfection process takes place.

### **7.3 Production of Silver Nanoparticles**

Zero-valent (colloidal) silver can be engineered into fine particles in the nanometer size range. As mentioned above, when at least one dimension of these particles is smaller than 100 nanometers, these particles are commonly called colloidal silver or, more recently termed, silver nanoparticles.

Silver nanoparticles can be synthesized using a variety of techniques, including chemical reduction methods (Soukupova *et al.* 2008), irradiation methods (Long *et al.* 2007), and electric spark discharging methods (Tien *et al.* 2008).

#### **7.3.1 Chemical Methods**

The most common way to synthesize silver nanoparticles is the chemical reduction of a silver salt solution, such as silver nitrate, by a reducing agent such as borohydride, citrate, ascorbate, or a reducing sugar (Soukupova *et al.* 2008). The size of the particles can be manipulated depending on the reducing agent used, for example, using disaccharides as a reducing agent yields a smaller particle size than using monosaccharides. The reduction of silver ions in aqueous solutions generally yields silver nanoparticles with particle diameters of

several nanometers. Initially, the reduction of various complexes with  $\text{Ag}^+$  ions leads to the formation of silver atoms  $\text{Ag}^0$ , which is followed by the agglomeration into clusters. These clusters eventually lead to the formation of silver  $\text{Ag}$  particles.

The synthesis of colloidal silver by chemical reduction methods is often performed in the presence of stabilizers in order to prevent unwanted agglomeration of colloids. Some stabilizers commonly used are polyvinyl alcohol, bovine albumine, citrate, and starch. Solid surfaces can also be used to stabilize colloidal particles, in which case, silver nanoparticles are formed and immobilized on the surfaces of different solid materials that can be added to solid matrices or can provide settling properties (solid/liquid separation). Clays, such as montmorillonites, zeolites, and laponites, silica spheres, hydroxyapatite, ceramic, and cellulose fabrics are the more common surfaces used for this purpose.

### 7.3.2 Irradiation Methods

Colloidal silver solutions can also be prepared by photo-irradiation of a silver source (such as silver salts), without the addition of chemical reducing agents. This process has been used since the 18<sup>th</sup> century for photographic film emersion (Long *et al.* 2007). Lasers, microwave, UV-light, and white light have been reported as irradiation sources for the formation of colloidal silver. Silver nitrate and silver perchlorate have been used as silver sources for irradiation methods.

### 7.3.3 Electrochemical Methods

Electrochemical methods are also called “sacrificial anode methods” or “electric spark discharge.” In this case, two silver wires are used as electrodes (positive and negative). The silver electrodes are placed in a high voltage setting so that silver nanoparticles are synthesized through a sparking process. This creates sufficient zeta potential for a stable silver nanoparticle aqueous suspension (Figure 7-3).

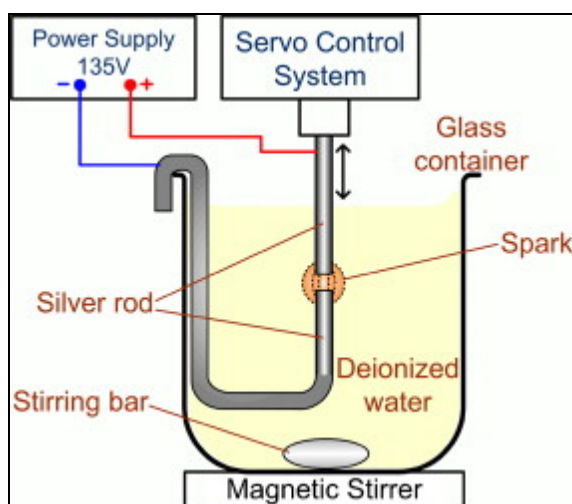

Figure 7-3: Schematic of System used for Electrochemical Reduction of  $\text{Ag}^+$  to  $\text{Ag}^0$

## 7.4 Silver in Ceramic Water Filters

Silver is applied to the filter for two reasons: 1) to take advantage of the bactericidal quality of silver in the purification of water as it is filtered; and, 2) to prevent the growth of a “slime layer” of bacteria that can form on the filter wall. Ceramic filter producers currently use different silver products and application methods. These are summarized in Table 7 and Section 3.9.

The most commonly used silver nanoparticle is Collargol (powder) which is produced by Argenol Laboratories. The zero-valent silver nanoparticle content of Collargol is produced through chemical reduction of silver nitrate ( $\text{Ag}^+$  and  $\text{NO}_3^-$ ). After the reduction process a protein is added to stabilize the nanoparticle suspension. The total amount of silver in Collargol varies from 70% to 75% in weight. Other silver compounds used in ceramic filter factories are Ultra Silver, distributed by Snow Fresh (colloidal silver used by the Ixtatán Foundation), a 3.2% liquid colloidal silver sold by Argenol Laboratories, a 3.2% liquid colloidal silver sold by Reickerman-Spraylat, and silver nitrate (RDI-C, Indo-2, and ThirstAid).

The main reasons for using silver nitrate rather than colloidal silver are the lower price and local availability of silver nitrate. RDI-C claims that most of the silver nitrate is reduced to  $\text{Ag}^0$  either through photo or chemical reduction once it is applied to the ceramic filters because some inorganic groups in the ceramic matrix could act as a reducing agent (RDI-C 2009). Information was not provided to support these claims; however, the organization says the results will be published in a peer-reviewed publication in the near future.

The two most common methods of applying silver are brushing and dipping, although some factories include silver in the clay mixture and fire it into the filter. According to organization protocol, the amount of silver (ionic or nanoparticles) applied to each filter ranges from 80 to 300 mg (Table 7); however, the amount of silver applied to each filter by brushing reported by factories, ranges from 32-96 mg per filter (Table 5). Regardless of the application method and the silver product used, information is not available about the criteria used for the selection of either the silver compound or the application method.

Table 7: Current Application Protocol, Techniques, Products, and Concentration of Silver Nanoparticles in Ceramic Filters

Organization	Product	Method	Concentration	Volume	Ag added	Cost/ filter
Practica	Collargol	Dipping	245 mg/L	400mL	100 mg	\$0.11
PFP	Collargol	Brush	1 g/L	300mL	300 mg	\$0.33
FilterPure	Collargol	Fired in	N.I.	N.I.	N.I.	N.I.
RDI-C	Silver nitrate	Brush	32 mg/L	300mL	70 mg	\$0.09
Ixtatán	Ultra silver <sup>1</sup>	Brush	200 mg/L	400mL	80 mg	\$0.2
Thirst Aid	Silver nitrate	Brush	250 mg/L	300mL	80 mg	N.I.

1: Ixtatán foundation may change to Collargol; N.I. = no information; Contact ThirstAid for information.

The main goal of all three methods of application is to provide a homogeneous distribution of silver throughout the ceramic filters, maximizing the contact between the pathogens and the silver compounds. Each of the application method has advantages and disadvantages that are summarized in Table 8.

Table 8: Advantages and Disadvantages of Silver Application Methods

Method	Advantages	Disadvantages	Concerns
Dipping	<ul style="list-style-type: none"> <li>One batch can be prepared for several filters</li> <li>Faster application</li> </ul>	<ul style="list-style-type: none"> <li>Potential large volumes of waste</li> <li>Difficult to determine amount of silver absorbed by each filter</li> </ul>	<ul style="list-style-type: none"> <li>Potential silver segregation to the surface of the filter during drying</li> <li>Workers exposed to high concentration of colloidal silver</li> </ul>
Brush	<ul style="list-style-type: none"> <li>Amount of silver added to each filter is controlled</li> </ul>	<ul style="list-style-type: none"> <li>Application is more labor intensive</li> </ul>	<ul style="list-style-type: none"> <li>Potential silver segregation to the surface of the filter during drying</li> <li>Frequent worker exposure to low concentration of colloidal silver</li> </ul>
Fired-in	<ul style="list-style-type: none"> <li>It can be included when mixing the clay and sawdust</li> </ul>	<ul style="list-style-type: none"> <li>Colloidal silver in the dry form may have a larger average particle size distribution than in suspension</li> <li>A potential large amount of waste as silver is included in all filters, even those that might get rejected</li> </ul>	<ul style="list-style-type: none"> <li>Colloidal silver oxidation during firing</li> <li>Worker exposure to airborne silver nanoparticles</li> </ul>

Few studies have determined the efficiency of silver compounds applied to ceramic filters (Table 9). To our knowledge only one study comparing the performance of untreated ceramic filters to those impregnated with silver nitrate has been performed in the field (Brown *et al.* 2007). This study did not find differences between filters with and without silver application.

Table 9: *E. coli* Removal in Ceramic Filters with and without Silver Application

Author	Type	No silver	With silver
(Brown <i>et al.</i> 2007)	Field/Silver nitrate/RDI-C	95%	95%
(Lantagne 2001a)	Lab/Microdyn/PFP	97%	>99%
(Oyanedel-Craver and Smith 2008)	Lab/Collargol/L=0.2/Lab	97%	99.99%
(van Halem 2006)	Lab/Collargol/PFP	80%-99.7%	99.999%

At laboratory scale and under controlled conditions, there seems to be some evidence that the application of silver nanoparticles could increase the removal efficiency of pathogens. Although in the field silver nitrate has not been shown to increase bacterial removal in filters, in the lab, with high bacteria concentrations, filters impregnated with silver have consistently demonstrated better performance than filters without it.

One of the main concerns about the application of silver compounds to ceramic filters is the release of silver (ionic or colloidal) from the filters over time. The loss of silver from the filters has two main disadvantages: 1) potentially undesirable health effects for filter users; and, 2) reduction of disinfectant efficiency. A summary of silver concentrations in filtrate water from different ceramic filters both in field and laboratory applications is presented in Table 10. All the values reported are below the US Environmental Protection Agency (EPA) and WHO secondary standards for silver (0.1 mg/L), with the exception of RDI-C filters. It must be noted that the values of silver are not reported in the RDI-C manual and were estimated using the information provided in the report (30% silver release and 33 L of rinse before use) (Hagan *et al.* 2009). A recent study by Bielefeldt *et al.* (2009) showed that the efficiency of ceramic filters decreased to 0.2 to 2.5 log reductions after loading multiple batches of highly contaminated water. The study reported that the impregnation of silver has a beneficial effect in terms of bacteria removal, but it is not enough to sustain high efficiencies for a long period of time.

Table 10: Silver Release from Ceramic Filters

Author	Study type and silver type	Max silver concentration (mg/L)	Method	Digestion	Bacteria removal
(Lantagne 2001b)	Field/Microdyn	0.015	HACH	No	--
(Kallmand 2010)	Field/Snow fresh	0.09	HACH	No	99.99%-91.37% <i>E. coli</i>
(Hagan <i>et al.</i> 2009)	Field*/Silver nitrate	0.63	N.I.	N.I.	95%
(Bielefeldt <i>et al.</i> 2009)	Lab/Collargol	0.00175mg/L	ICP-MS	N.A.	99.99%-10% <i>E. coli</i>
(van Halem 2006)	RDI-C/PFP/Ghana	0.015 mg/L	ICP-MS	N.A.	--

N.I. = no information; N.A. = Non applicable; ICP-MS = Inductively coupled plasma mass spectrometry

Regarding the procedures used to determine the silver concentration in water treated with ceramic filters, although flame atomic absorption and inductively coupled plasma mass spectrometry (ICP-MS) are both capable of determining total silver, they cannot differentiate between ionic and colloidal silver. An additional step of ultracentrifugation may be performed before analysis so that the supernatant may be tested, allowing for determination of the ionic silver fraction. The HACH spectrophotometric method can only determine dissolved silver; however, if the sample is digested, it could be possible to determine total silver. To date, no study has determined the speciation of the silver released from the filters. This information

could be very important, especially considering that the EPA could set new standards for silver depending upon the form (ionic or nanoparticle) that is present in water.

The release of silver from the filters can be affected by factors such as the chemistry of the water to be treated (ionic strength, dissolved compounds, pH, and Oxidation-Reduction Potential) and interactions with the ceramic matrix (predominant clay, porosity, pore size, and surface area).

## 7.5 Environmental and Health Concerns

The lower thresholds for silver ion ( $\text{Ag}^+$ ) toxicity lie between 0.01 and 0.1 mg/L. The WHO has established that 0.1 mg/L of silver in drinking water can be tolerated without risk to human health (WHO 2004). The only adverse effect resulting from chronic exposure to low levels of silver ions in animals and humans is a blue-gray discoloration of the skin and internal organs, termed argyria. The WHO guideline is set to prevent argyria from a 70-year cumulative dose of 10 g (one-half of the human “no observable adverse effect” level). In humans, silver ions cannot cross the blood–brain barrier and are regulated by blood metallothioneins, which bind them in metal-thiolate-cluster structures for transport, storage, and detoxification.

With regards to the toxicity of silver nanoparticles, a number of recent studies have observed cytotoxicity (cellular death or reduction of mitochondrial activity) in rat liver cell cultures (Hussain *et al.* 2005) and aquatic organisms (*Chlamydomonas reinhardtii*) (Navaroo *et al.* 2008) at concentration of 1000 mg/L and 100 mg/L of silver nanoparticles, respectively. The first case of silver cardiomyopathy in humans due to the ingestion of colloidal silver as a food supplement was reported recently (Archer 2008). These studies highlight that silver in high concentration can be toxic.

Although silver concentrations measured in filter effluent are below the EPA and WHO secondary standards for silver (0.1 mg/L), filter manufacturers should recommend that filter owners use the first three flushes of water from the filter to wash the receptacle and tap since: 1) the first few batches contain a higher concentration of silver; 2) the receptacle and tap could have become contaminated during transport; and, 3) the initial water has a bitter taste which might discourage filter acceptance.

## 7.6 Silver Application Guidelines

It is recommended that 64 mg of silver be applied to each filter by brushing on 302 mg of a 211 mg/L solution. Before silver application, filters should have already passed other quality control inspections, including flow rate testing (Section 8.3), and filters should be completely dry in order to promote the absorption of silver.

The silver application area should be set up in an area not directly exposed to light, with a roof to minimize the exposure of silver to ultraviolet light and to protect the area from rain. It is important to minimize the introduction of silver to the environment as it can upset the natural ecosystem; therefore, the floor of the silver application area should be covered with fired, broken, rejected filters or other fired ceramic material that will absorb silver if spilled. If spillage occurs, the ceramic material exposed to the silver should be disposed of in a sealed plastic bag, or in compliance with local regulations. The mixing and application table should be covered with plastic. Health and safety precautions to take when handling silver include the use of gloves and a lab coat or apron. When handling powdered silver a facemask and



goggles should also be worn. These precautionary measures should be used in addition to local health and safety regulations.

For powdered silver, a week's worth of 3.2% (32,000 mg/L or ppm) concentrated silver can be prepared in advance and then further diluted to application strength (0.021%) on a daily basis. Preparing a concentrate will both reduce exposure to airborne silver particles and aid in accurate measurement of silver. Calculations for preparing a concentrated solution are provided in Annex H. Both powdered and concentrated silver should be labeled, stored in airtight containers, and protected from UV exposure.

It is recommended that concentrated silver be diluted to the application strength immediately before applying it to each filter. The application solution should be prepared in a clean container using the cleanest nonchlorinated, boiled, filtered, de-ionized, or bottled water available. The silver should suspend readily in water, that is, the silver particles should not settle to the bottom of the jar as soon as it has been mixed. If settling occurs, the silver should not be used and the supplier should be contacted. If a known number of filters are to be treated in a given day, the appropriate application amount may be diluted daily (Annex H).

The standard amount of colloidal silver added to each filter (established empirically at filter factories) using a brushing application technique, is 2 mL (cc's) of 3.2% liquid colloidal silver, added to 300 mL of water. This has a concentration of 211 ppm (211 mg silver per liter of water). When all 302 mL is applied to one filter, the filter will be coated with 64 mg of colloidal silver.

The date the silver concentrate was prepared, the strength of the silver concentrate, the quantity of silver concentrate added, the quality and quantity of water added, the quantity of silver solution brushed on to each filter, and the date of application should be recorded on the filter log.

### **7.6.1 Silver Application Technique**

Application strength silver should be applied to the inside and outside surfaces of the filter by brushing approximately 100 mL onto the inner surface of the filter, then 100 mL onto the outer surface, and the remaining 100 mL onto the inside. To guide in measuring the quantity applied, marks may be drawn on the outside of the application container at 100 mL, 200 mL, and 300 mL. The following steps will ensure that the entire volume of solution is applied to the filter and the entire surface of the filter is coated:

- 1) Prepare 302 mL of colloidal silver dilution by adding 2 mL of 3.2% colloidal silver to 300 mL of water.
- 2) Using a paint brush (approximately 3" wide), coat the inside of the filter starting on the bottom. Each dip in the liquid should be applied with two strokes on the filter.
- 3) Brush one coat on the outside of the filter, starting at and including the rim, and then the bottom of the filter.
- 4) Brush the remaining 100 mL on the inside of the filter element, starting at and including the rim, working downwards, and including the bottom of the filter.

## 7.6.2 Other Forms of Silver and Application Techniques

Silver nitrate is not recommended until further research has been carried out since silver nitrate may disassociate at a faster rate than colloidal silver causing concern with: 1) the amount of time silver nitrate lasts in the filter; and, 2) whether the amount of silver that initially leaches into filtered water exceeds WHO guidelines.

Until further research has been carried out, application of silver by dipping is not recommended because: 1) the amount of silver actually applied to the filter cannot be controlled and it is unknown how much silver is actually absorbed by the filter; 2) the concentration of the bulk dilution cannot be measured easily or controlled and might change after each filter is dipped; 3) there are environmental concerns with disposal of unused diluted silver; and, 4) associated health and safety risks from increased exposure to silver nanoparticles are unknown.

Currently we do not recommend including silver in the filter mixture as information is not available regarding the quantity of silver that should be added to the filter mixture. If silver is to be included in the filter mixture, it should be diluted in water first, and then added to the dry filter mixture to minimize exposure to airborne silver particles. A facemask, gloves, goggles, and apron should be worn when handling powdered silver.

## 7.7 Recommendations

Based on the knowledge summarized in the previous sections, the following recommendations are made to filter manufacturers by the Working Group:

- 1) Ceramic filter manufacturers should apply colloidal silver to their filters, both to prevent bacterial growth in the filter (Silversty-Rodriguez 2008) and to potentially increase the microbiological reduction through the filter.
- 2) Filters should pass all other quality control inspections before applying silver to avoid wasting silver on noncompliant filters and to reduce the amount of silver released into the environment.
- 3) Colloidal silver should be diluted with nonchlorinated boiled, filtered, bottled, or deionized water, preferably with a low calcium concentration (to prevent the aggregation of silver particles).
- 4) Powdered, liquid, and diluted silver should be stored in a dark, airtight container to protect it from oxidation and ultra-violet light.
- 5) Approximately 64 mg of silver colloidal silver should be applied to each filter by brushing on 302 mg of a 211 ppm solution.
- 6) Filter manufacturers should be aware that there are potential problems with dissociation from the filter when using silver nitrate, so until further research has been carried out we do not recommend the use of silver nitrate on filters.
- 7) Filter manufacturers should recommend that filter owners use the first three flushes of water from the filter to wash the receptacle and tap because: 1) the first few batches contain a higher concentration of silver; 2) the receptacle and tap could have become

contaminated during transport; and, 3) the initial water has a bitter taste which might discourage filter acceptance.

- 8) Health and safety guidelines must be adhered to including the use of gloves and an apron when working with liquid silver, and the additional use of a face mask and protective eyewear when working with powdered silver.

## **7.8 Areas for Further Research**

The following areas require further research in order to refine recommendations for best practice in ceramic water filter production:

- 1) How much silver needs be applied to the filter to make it effective? This requires balancing the desired bactericidal effectiveness with concerns about the quantity of silver in effluent water and the safety of the workers applying the silver.
- 2) How much silver leaches out of a filter over time and how quickly? This has implications for potential user consumption of silver effluent, filter bactericidal effectiveness, and the projected useful life of the filter element.
- 3) How does the quality of the water to be filtered, such as the concentration of ionic salts, which are typically higher in groundwater than in surface water, affect the leaching of silver from the filter and the effectiveness of the filter? Are there circumstances when different types of silver (silver nitrate vs. colloidal silver) are appropriate to use?
- 4) Is silver nitrate as effective as colloidal silver, in terms of both its effectiveness as a disinfectant and its ability to bond with the clay matrix? How does silver nitrate disassociate from the filter? Is there more worker safety risk associated with the use of silver nitrate because it can be reduced more easily than colloidal silver?
- 5) What are the effects of filtering chlorinated water through the filter? What is the nature of the silver/chlorine interaction? Does it compromise or improve upon the silver's bactericidal effectiveness?

## **7.9 Chapter Details**

The information in this chapter was collated by Vinka Craver and edited by Justine Rayner and Daniele Lantagne. Participants on this conference call to discuss this chapter included Mike, Justine, Vinka, Daniele, Tracy, Lisa, Robert, Terry, and Manny.

## 8 Variables: Quality Control

In this chapter, recommended quality control procedures for testing finished filters are presented. The chapter begins with an introduction to quality control and a table outlining recommended quality control tests and the frequency with which they should be carried out. This is followed by a description of indirect quality indicator tests and microbiological testing guidelines. The chapter concludes with a summary of recommendations and a list of areas where further research is needed.

### 8.1 Introduction

The recommendations presented in previous chapters provide suggestions for the evaluation of materials, recommended manufacturing procedures, and the documentation of daily production. A systematic approach that ensures that manufacturing steps are completed as consistently as possible is important to ensure a quality product, reduce the chances of a high filter failure rate, and avoid extra costs incurred by the absence of quality control measures. Consistent materials and consistent manufacturing methods should produce consistent filters. Production consistency is critical to ensure that filters tested for microbiological removal efficiency are representative of their batch. On the production floor documentation can be seen as an unnecessary hindrance, but accurate documentation allows the production details of each filter to be referred to and compared with filter characteristics or quality.

The identification of filters that do not meet quality control standards is essential. Although the implementation of strict quality control procedures may increase the rejection rate initially, by documenting and evaluating failed filters, and identifying and changing the processes during which problems occurred, both the consistency and the quality of filters produced will improve.

Filters should be evaluated individually, but also within the context of their batch. If there is a high failure rate within a batch, the materials and manufacturing process need to be reviewed and that batch should not be released for sale or distribution until the cause(s) of the failure(s) is identified and corrected. Likewise, if filters pass other quality control tests but do not pass microbiological testing, the manufacturing of that batch needs to be reviewed. Failed filters and reasons for rejection should be recorded. Average failure rates and reasons for failure should be monitored over time. Production practices should be evaluated to identify the reason(s) for a change in failure rate.

Each employee plays an important role in producing high-quality ceramic filters and should understand the reasons behind each procedure. Their suggestions should be considered for incorporation into an effective program. A chain of communication for making suggestions and reporting concerns should be established. Recognition of employees for good effort in quality control measures and documentation can increase the level of participation by each individual. If a bonus or awards program is implemented, emphasis should be placed on catching defective filters, rather than achieving the lowest rejection rate by passing as many filters as possible.

This ongoing process of evaluation and documentation will ensure that the quality control system is monitoring the filter quality to an acceptable standard and will allow for improvements and revisions based on a review of data over time.

### **8.1.1 Factory Reviews**

Factories are encouraged to carry out regular internal and/or external reviews: 1) after installation of any new factory; 2) immediately before the initial release of filters for consumer use; and, 3) annually. Factory reviews should include a summary of the quality control measures in place, indirect indicator and microbiological testing results, new material sourcing, number of filters sent through production process, number of rejected filters and reasons for rejection, and results from independent testing (i.e., by NGOs).

### **8.1.2 Certification, Research, and Independent testing**

Each filter factory is encouraged to coordinate with the local government or other authority to determine applicable regulations and ensure that those regulations are met. When possible, factories should obtain certification from the local government.

Factories are encouraged to work with academic researchers, international or local NGOs, health clinics, national health organizations, or other relevant institutions to continue to prove the performance of their filters. Having documented results from independent laboratory testing will be helpful to both consumers and organizations interested in purchasing or promoting the filters.

## **8.2 Quality Control Program**

All factories should: 1) consult an experienced filter technician during factory set-up; 2) establish a quality control program; 3) maintain recommended documentation during prototyping and throughout production; and, 4) follow recommended testing procedures. Records and data should be kept for a minimum of 10 years.

The quality control program is designed to:

- 1) Evaluate the quality and consistency of materials and ensure that production processes are carried out consistently as recommended in Sections 4-7.
- 2) Ensure that materials evaluations and manufacturing processes are documented as recommended in Sections 4-7.
- 3) Ensure that manufacturing consistency is confirmed through the performance of various tests as outlined in Section 8.3.
- 4) Ensure that product quality is confirmed with microbiological testing as outlined in Section 8.3.5.

Recommended quality control procedures and the recommended frequency with which they should be carried out are shown in Table 11. Factories that meet these guidelines are setting the worldwide standard for ceramic filter production.

Table 11: Quality Control Procedures and Testing Frequency

Category	Quality Control Measure	Description (page)	Minimum Testing Frequency
Materials	Source Water Quality (full laboratory analysis)	45	at project outset; yearly; more frequently if intermittent or less safe water source
	Water of Plasticity (Clay)	156	initial sourcing; new raw material; change in material characteristics; annually
	Shrinkage of Dried Clay	156	
	Shrinkage of Fired Clay	157	
	Total Shrinkage of Clay	157	
	Absorption of Fired Clay	157	
	Burn-out Description	55	
	Burn-out Particle Size	55	
	Burn-out Moisture Content	158	
	Burn-out Firing Test	158	
Tap Leak Test	164	if of concern	
Equipment	Sieves (hammermill screen & sifter)	52, 55	daily
	Mold Alignment (Wet and Fired Filters)	66, 163	before start of production; installation of new mold; when misalignment is suspected; 0.4% of fired filters
	Kiln Temperature Mapping	164	2 runs on new kiln; if firing is inconsistent; annually
Process	Dry & Wet Mixing	63	per batch
	Filter Shape	67	each filter
	Drying	68	each filter
	Visual Inspections	112	each filter; stages include: pre-surface finishing, pre-firing, pre-flow rate testing, pre-silver application, pre-packaging
	Soaking and Flow Rate Testing Water Quality	45	evaluated daily
	Establishing Saturation Time	114	before production begins; annually
	Silver Solution Preparation	104, 173	per filter or daily
Silver Solution Application	104	each filter	

<b>Category</b>	<b>Quality Control Measure</b>	<b>Description (page)</b>	<b>Minimum Testing Frequency</b>
Quality Control of Final Product	Independent Laboratory Analysis (Heavy metals, other contaminants)	120	prototype filter effluent; change in raw materials; more frequently depending on local contaminants or concerns
	Independent Lab Analysis (Microbiological)	116	3 prototype filters from 3 batches before production begins; change in mixture ratio; quality control concern; 0.1% of filters destined for sale/distribution
	Membrane Filtration (MF), Most Probable Number (MPN), or Semi-Quantitative Risk Level (in addition to laboratory testing)	118	before production begins; change in mixture ratio; quality control concern; 1% of filters destined for sale/distribution (minimum one filter per firing batch), in addition to laboratory testing
	Auditory Test	88, 113	each filter
	Filter Rim Size Test	113	each filter
	Pressure Test	113	each filter
	Flow Rate	114	each filter

## 8.3 Quality Control of Final Product

Quality control tests of the finished filter can be divided into two categories: direct and indirect tests. Direct tests evaluate microbiological removal efficiency. Due to the associated costs, microbiological testing may be carried out on a sample of filters; however, manufacturing consistency must be verified in order to establish that the samples are representative. Indirect tests are carried out to evaluate manufacturing consistency. Indirect tests should be carried out on 100% of the filters considered for consumer use.

Indirect tests include visual inspection, auditory testing, pressure testing, and flow rate testing. In addition, the filter rim should be checked to ensure that it fits the receptacle properly. These evaluations should be conducted before silver application so that neither silver nor application time are wasted on filters that will potentially be rejected by quality control and to minimize the amount of silver discarded into the environment.

Factories should strive to achieve a consistent rejection rate of 10%, although 15-20% can also be considered acceptable. Although manufacturing cost is an important criterion for defining acceptable failure rates, a rejection rate of more than 20% or a change in the average rejection rate indicate inconsistency in production practices, materials, or methods and should not be considered acceptable. Conversely, a rejection rate of less than 5% likely indicates that quality control evaluations are not strict enough.

### 8.3.1 Visual Inspections

Visual inspections should take place before each major step of the production process so defective filters can be removed from the production line. Formal visual inspections should be carried out and documented before: 1) surface finishing; 2) loading the kiln; 3) flow rate testing; 4) silver application; and, 5) packaging. The documentation of each formal visual inspection, including the production stage and description of the defect, will help when troubleshooting a quality control concern and will also encourage employees to give their full attention to the visual inspection process.

At the Indo-2 factory, to emphasise and reinforce the importance of filter inspections, two people perform visual inspections of finished filters using a magnifying glass; defects are marked with chalk. Defective filters are compared and analyzed to establish the cause of the defect.

In the greenware state, filters should be examined for cracks, warping, inconsistent filter walls, large pieces of burn-out material, and inconsistent surface. In fired filters, filters should be examined for discoloration (including blackened areas indicating insufficient oxidation during firing), warping, cracks, holes or spaces from large pieces of burn-out material, charring, and crumbling. The angle between the rim and wall of the filter and between the base and wall should also be checked for proper alignment.

The filter rim of fired filters should be checked for size and warping by placing a receptacle lid on each filter element. Turn the lid slowly and check that the filter rim meets the lid evenly. If the lid does not fully cover the filter rim, grind the filter rim to fit, taking care to not damage the body of the filter or grind any more material than necessary. The filter rim must still be wide enough to cover the rim of the fitting ring or receptacle, so that untreated water or other debris cannot enter the filter during use; otherwise the filter must be rejected.



### 8.3.2 Auditory Testing

Auditory testing can identify incomplete firing or cracks in the filter walls. After being fired, each filter should be tapped to check for a ringing sound. A suggested test method is as follows:

- 1) balance the filter by its base on an open hand or outspread fingers;
- 2) tap or knock near the rim of the filter, as if ringing a bell;
- 3) if dull thud is heard, the filter should be rejected;
- 4) tap the filter in at least three locations around the rim of the filter.

In Myanmar, third party inspections are performed on a random selection of 5% of all filters sold to NGOs. If any filters fail inspection, the entire shipment is held up until the issue is resolved.

A properly fired filter will make a ringing sound. A filter that makes a blunted, shorter sound, almost a thud, is cracked or improperly fired and should be rejected.

In addition, the open end of the filter can be held up to one's ear and the filter walls gently squeezed. A slight crunching sound will be heard if there are cracks present, and that filter must be rejected.

### 8.3.3 Pressure Testing

Before saturating filters for flow rate testing, a pressure test should be carried out on all fired filters to check for cracks or large pores that allow water to pass through the filter walls too quickly. This test should be performed as follows:

- 1) hold the filter by the rim;
- 2) submerge the filter base in water until the water level is near the rim. Do not allow water to flow into the filter (Figure 8-1);
- 3) keep the filter submerged for 10 seconds;
- 4) if evidence of water entering the filter (Figure 8-1) is present after 10 seconds, especially if it seeps in unevenly, the filter has cracks or large pores and must be destroyed.

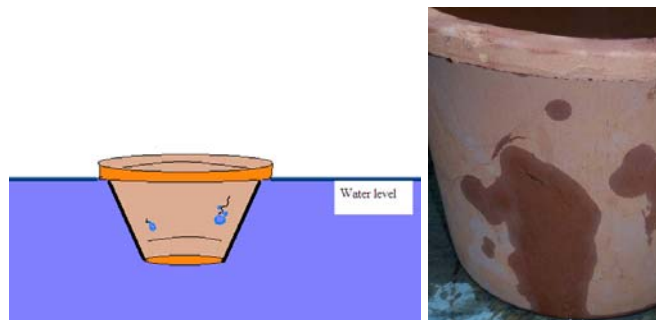

Figure 8-1: Pressure Test and Evidence of Leaks (Pillers and Diaz 2009)

Another way to carry out the pressure test is to invert the filter and fully submerge it rim down in water, trapping air inside the filter. The presence of large pores or cracks may be identified by a stream of bubbles coming from the wall or base of the filter. If a stream of bubbles appears, the filter must be destroyed.

### 8.3.4 Flow Rate

The flow rate is the amount of water that passes through a full, saturated filter in the first hour. It is used as an indicator of production consistency, potential contact time with silver, and can also identify cracks or large pores in the filtering element.

The Myanmar factories report that filters (10 L capacity) with flow rates of 3.5 and 4.5 liters in the first hour have the same likelihood of achieving a 2-log reduction of indicator bacteria.

The minimum flow rate is established based on consumer needs. A minimum flow rate of one liter in the first hour should provide enough drinking water for a family of five if the filter is filled 4-5 times a day. Filters that do not meet a minimum flow rate of one liter per hour should be rejected and destroyed since their failure to treat a sufficient quantity of water could cause the consumer to stop using the filter, thereby placing their health at risk. Filters that do not meet the minimum flow rate may not have reached the appropriate peak temperature during firing, so these filters can be refired. Often this will bring a filter into compliance, but if after a second firing, a filter still does not fall within the flow rate range, it should be destroyed.

Since the amount of time it takes water to pass through the filter will influence some mechanisms of filtration, the thickness of the filter walls and the surface area of the filter should be taken into consideration when determining the maximum flow rate for each filter design. Assuming a minimum 2 cm base thickness and 1.5 cm wall thickness in flat-bottomed filters or 1.5 cm wall thickness in rounded-bottomed filters, the maximum flow rate should be calculated at 0.35 liters per hour per liter capacity of the filter element. Therefore, the maximum flow rate for 7.2-liter capacity filters should be 2.5 liters in the first hour, and a 10-liter capacity filter should have a flow rate of no more than 3.5 liters. Maximum flow rates should be confirmed with microbiological testing and filters that exceed the acceptable flow rate should be destroyed.

While the hydraulic conductivity will influence filtration mechanisms and treatment effectiveness, the flow rate does not guarantee microbiological efficacy. When a factory is first started, prototype filters that meet the flow rate requirements are manufactured and tested for microbiological effectiveness. Since there are many production variables that can influence the flow rate (Section 5.2), filters must be produced with similar materials and methods and fall within the flow rate range in order to be considered representative of the prototype filters. When materials or production vary, microbiological effectiveness must be confirmed, as during prototype evaluations. If there is a high variation in flow rate within a given batch, indicating inconsistency in production, that batch must be held from distribution or sale until microbiological efficacy is confirmed and the materials and production of that batch are evaluated.

#### 8.3.4.1 Establishing Saturation Time

For reliable results, filters should be saturated before flow rate testing (Lantagne 2001a). Although the amount of time required to ensure saturation might vary per factory, Nederstigt and Lam (2005) found that after having soaked for 24 hours, filtration rates became constant. Filters soaked for fewer than 24 hours had lower flow rates (van Halem 2006: A-10). Water quality requirements for soaking filters are discussed in Section 4.1.

In order to establish the amount of time it takes to saturate the filters to achieve a consistent flow rate, a number of filters that have been taken from different locations in the kiln should

be fully submerged. The time the filters are submerged should be recorded. At regular intervals, filters should be removed from the water and their flow rate tested, and the filters returned to the soak tank. When the filtration rate of a specific filter is consistent for two or three consecutive readings, that filter can be considered saturated for flow rate testing purposes. The maximum time it takes the sampled filters to become saturated can be used as the minimum time necessary for saturating filters for future flow rate testing. Saturation time can be expected to be at least 12 hours, and as much, or more than, 24 hours. Based on variations in materials and manufacturing, a different saturation time may be required for each factory; however, filters should be soaked for a consistent amount of time at each factory. This saturation test should be carried out periodically to confirm that filters continue to be fully saturated before flow rate testing.

#### **8.3.4.2 Flow Rate Testing**

The flow rate can be tested by measuring the amount of water filtered after 1-hour. With flat bottomed filters, rather than measuring the amount of water filtered (effluent), the drop in water level can be measured using a calibrated T-device (Figure 8-2). Instructions for making a T-piece are in Annex I. Since the drop in water volume will result in a reduced hydraulic head, the filtration rate will slow as the filter empties; therefore, readings taken after half an hour and then doubled may not provide accurate readings. Water quality requirements for flow rate testing are discussed in Section 4.1.

Saturated filters should be placed in an empty bucket or receptacle supported by the rim only. Flat-bottomed filters should not be resting on their base, as this will reduce the flow rate. Likewise, if the water level in the receptacle reaches the bottom of the filter, the flow rate results will not be accurate. Therefore, if the maximum allowed flow rate is 2 liters in the first hour, there should be room for more than 2 liters of water in the receptacle so that, within the acceptable flow rate range, the water level does not reach the base of the filter element.



Figure 8-2: Calibrated T-device (source unknown)

Filters should be completely filled with water and allowed to filter for 1 hour. If measuring the effluent, carefully remove the filter so that the water remaining in the filter does not spill into the receptacle. Measure the quantity of water that passed through the filter into the receptacle. Alternatively, if it is possible to see the water level through the bucket, lines can be drawn on the bucket at half-liter intervals; however, the receptacle must be on a level surface for this to be accurate. When using a calibrated T-device, the drop in water level can be measured after 1-hour.

Flow rates should be recorded on the filter production log. Average flow rates should be monitored throughout production. Filter elements that fall within the acceptable flow rate range can be emptied and left to dry before silver application and packaging. However, if there is a large variation in flow rates for filters in a given batch, the production records for that batch should be reviewed and compared with the records and results from other batches to see if the cause(s) can be identified, additional microbiological testing should be carried out, and that batch may need to be withheld from distribution until causes are identified and efficacy confirmed.

### 8.3.5 Microbiological Testing

Each factory should establish a testing protocol for both independent laboratory and in-house testing which includes: frequency of testing; percentage of filters from each batch tested; the method for selecting filters; indicator used; and, testing methods.

At the FilterPure factory in the DR, no changes in production procedures are allowed until efficacy is confirmed by microbiological testing.

At a minimum, microbiological efficacy must be confirmed by independent laboratory testing on at least three prototype filters from three different filter batches (a total of nine filters) before production starts, when the mixture ratio or other aspect of production varies, or when a quality control issue arises. Throughout production, for continued verification of production methods, a minimum of 0.1% of filters should be tested at an independent laboratory. When taking samples to a laboratory for testing, the laboratory should be contacted in advance for requirements and guidelines for sample collection. In addition, at least one filter per firing batch and a minimum of 1% of filters destined for sale (that have passed all other quality control inspections) should be tested in-house, at the factory.

If possible, more filters should be tested, the same filters should be tested more than once to confirm results, and an increased number of filters should be tested if there is a change in production or a change in the quality or consistency of filters produced.

Filters selected for testing should be representative of their batch; therefore, they should be selected from different drying locations, different locations in the kiln, from those manufactured during different shifts during the work day, and so on. Microbiological testing should be carried out on filters that have already passed other quality control inspections and tests (Section 8.3), but before applying silver. This avoids wasting money and time testing noncompliant filters, prevents the initial high silver concentration in the filter effluent from influencing test results, and finally, because the duration of the efficacy of silver is unknown, testing without silver provides a more reliable indication of long-term performance. Testing can be carried out on filters with silver if silver has been fired into the filters or if the objective of the test is to measure silver in filter effluent.

If a filter that has met all other quality control tests does not pass microbiological tests, the entire batch must be held from distribution until additional filters from that batch have been tested. The production records of that batch of filters should be evaluated and the problem(s) diagnosed and resolved. Following this, an increased number of filters from subsequent batches must be tested in order to confirm consistency in production. If filters consistently demonstrate microbiological effectiveness, the number of filters tested at an independent laboratory can be reduced, as long as all other aspects of production remain consistent and in-house testing continues. However, routine verification by an independent laboratory should never be eliminated and the frequency of testing should be increased again if any inconsistencies are noticed.

In Myanmar, a traveling technician with a field test kit visits each of the eight factories once per month and tests 10-15 randomly selected filters selected. The technician spends the night and shows the filter manufacturers the results in the morning.

The fact sheet *Microbiological Indicator Testing in Developing Countries: A Fact Sheet for the Field Practitioner* explains the different indicator bacteria and their usefulness; currently available and emerging field test methods including the benefits, drawbacks, and cost

considerations; and, detailed instructions for carrying out the tests. A copy of this document can be obtained by contacting Daniele Lantagne at: [dlantagne@cdc.gov](mailto:dlantagne@cdc.gov). Much of the following sections have been summarized from this fact sheet.

### **8.3.5.1 Indicator Organisms**

Due to the difficulty of monitoring water for specific contaminants, water is tested for the presence of indicator organisms associated with fecal contamination. Commonly used indicator organisms include: 1) total coliforms (TC); 2) thermotolerant or fecal coliforms (TTC); and, 3) *E. coli*. Criteria for indicator bacteria as outlined by the WHO (2006: 142) are that they should be:

- 1) universally present in high numbers in human or other warm-blooded animal feces;
- 2) readily detectable by simple methods; and,
- 3) should not grow in natural water.

Since some coliforms can grow and survive in water and are often present in the absence of fecal contamination, the TC count is not always useful in evaluating health risk; however, it can be useful as an indicator of treatment effectiveness (WHO 2006: 283). TTC are those of the TC group that are able to ferment lactose at 44-45°C. Some TTC are present in the natural environment in tropical countries. *E. coli*, often the predominant TTC organism, is rarely found in the absence of fecal contamination and is therefore a more reliable indicator of water safety, but both *E. coli* and TTC are considered acceptable indicators to measure water safety (WHO 2006: 284). Another indicator, hydrogen sulfide-producing bacteria, is not recommended for testing filter efficacy as currently there is no quantitative testing method available.

The choice of indicator bacteria will depend upon the quality of the challenge water and whether the safety of the water or the treatment efficacy is being tested. Since TC and TTC are more likely to be present in greater numbers, they are often used in place of *E. coli* to evaluate treatment efficacy (percent reduction or LRV). Ideally, filters should be challenged with water containing high concentrations of *E. coli* so that both percent reduction and the safety of the water can be evaluated.

In Myanmar, TTC are measured because TC concentrations are often very high.

### **8.3.5.2 Measuring Microbiological Efficacy**

Microbiological efficacy of filters can be measured by percent reduction of indicator bacteria expressed as LRV (Table 1) or by evaluating the risk level of treated water (Table 2). Challenge water must contain the indicator bacteria being tested for in order to test for treatment effectiveness.

To establish LRV, the indicator bacteria must be present in greater numbers and quantified in both the challenge and treated water. For *E. coli*, TTC, and TC, filters must, at a minimum, provide a 2-log reduction. This means that the effluent concentration of the indicator must be 1/100th or less than that of the influent concentration; thus, if the influent concentration is 1,000 CFU per 100 mL (CFU/100mL), then the effluent must have 10 CFU or fewer per 100 mL sample.

If the challenge water does not have a high enough concentration of indicator bacteria to measure log reduction, then the risk level can be assessed, in which case filtered water should have fewer than <10 CFU/100mL for any of these indicators.

### 8.3.5.3 In-House Testing Methods

Independent laboratory testing should be supplemented with in-house testing. In-house testing allows a greater percentage of filters to be tested because of the lower cost in comparison with having samples tested in a laboratory. In addition, the direct involvement of employees in quality monitoring allows them to see the results of the quality of the filters they produce. Experience in Myanmar has found that this involvement inspires filter producers to apply greater effort to produce high-quality filters.

Field test methods range in complexity, cost, the level of detail, and the quality of results. Field tests are available for *E. coli*, TTC, and TC. Methods that allow for the quantification of bacteria in both the influent and effluent water will provide information regarding treatment capability.

Three recommended methods for testing microbiological indicators are: 1) Presence/absence (P/A) in combination with Petrifilm™ for semi-quantitative risk level analysis; 2) Most probable number (MPN) with IDEXX™, which provides quantitative results using simple methods but is expensive; and, 3) Membrane Filtration (MF) which allows the number of CFU to be counted, can be inexpensive, but requires trained laboratory staff. The three methods will require sample collection, sample processing (including adding a specific growth media), and incubation for 24-72 hours. The manufacturer's instructions for specific tests should be followed; however, instructions on how to carry out each of these tests are provided in *Microbiological Indicator Testing in Developing Countries: A Fact Sheet for the Field Practitioner*. Table 12 shows a summary of the main advantages and disadvantages of each test method and approximate cost.

Table 12: Recommended In-house Testing Methods

Method	Equipment	Advantages	Disadvantages	Approximate Cost (US\$)
Semi-quantitative contamination level	P/A in combination with Petrifilm™	<ul style="list-style-type: none"> <li>• simple testing &amp; analysis</li> <li>• incubation might be suitable at ambient temperature</li> <li>• small size is easier to incubate</li> <li>• provides semi-quantitative contamination level (&lt;10, 10-100, &gt;100 CFU/100mL)</li> <li>• measures both TC and <i>E. coli</i></li> </ul>	<ul style="list-style-type: none"> <li>• not currently approved for water testing</li> <li>• imprecise (semi-quantitative) contamination level results</li> </ul>	\$1.00 per Petrifilm test; \$3-5 per P/A test

Method	Equipment	Advantages	Disadvantages	Approximate Cost (US\$)
MPN	IDEXX Quantitrays	<ul style="list-style-type: none"> <li>• simple testing &amp; analysis</li> <li>• reliable quantitative results</li> <li>• large range of contamination tested in one sample</li> <li>• fast sampling process</li> <li>• Measures both TC and <i>E. coli</i></li> </ul>	<ul style="list-style-type: none"> <li>• relatively large-sized disposable tray per test</li> <li>• relatively large incubation space required</li> <li>• electricity required</li> <li>• relatively large volume of equipment</li> <li>• high up-front cost for sealer</li> </ul>	\$5.00 for consumables per test; \$1,500.00 up-front cost for sealer
MF	Field kit	<ul style="list-style-type: none"> <li>• reliable quantitative results</li> <li>• easily transportable</li> <li>• few disposable parts</li> <li>• can be used with a variety of media</li> <li>• can be used with a variety of power sources</li> <li>• low cost per test if powdered media is used as Petri dishes are reusable</li> </ul>	<ul style="list-style-type: none"> <li>• laboratory-trained personnel needed as operators need to understand dilutions and run multiple samples</li> <li>• requires the use of reusable parts which must be sterilized between each sample</li> <li>• incubators only hold approximately 16 samples</li> <li>• slow sample processing</li> <li>• high up-front cost</li> </ul>	Less than \$1.00 per test (reusable petri dishes and powdered media); \$2,000.00 up-front cost for field kit
	Lab equipment	<ul style="list-style-type: none"> <li>• laboratory quality testing</li> <li>• reliable quantitative results</li> <li>• can be used with a variety of media</li> <li>• relatively small volume of equipment (less than IDEXX; more than the field kit)</li> <li>• fast sample processing</li> <li>• can use disposable or reusable parts</li> <li>• small incubation space required</li> <li>• does not require electricity, non-electric incubator can be used</li> </ul>	<ul style="list-style-type: none"> <li>• laboratory-trained personnel needed as operators need to understand dilutions and run multiple samples</li> <li>• significant amount of disposable equipment</li> <li>• manual processing</li> <li>• high-up front cost</li> </ul>	\$4.00 for consumables per test; \$1,000.00 up-front cost for laboratory equipment

### **8.3.5.4 Guidelines for Taking Samples**

Filters that have met other quality control criteria should be randomly selected from the batch (before silver has been applied). The receptacle and tap should be cleaned with a chlorine bleach solution and thoroughly rinsed and dried. Challenge water should come from a contaminated source, and since water characteristics vary and could influence the results, if possible, water similar to the source water consumers will be using should be used. The challenge (influent) water (positive control) should be tested first and then, after filtering for 1 hour, the effluent should be tested. When collecting filtered water samples, hands should be washed first and samples collected in sterilized plastic bags (for example, Whirl-Pak®) or sterilized disposable bottles to prevent contamination of the samples. All samples should be labeled carefully.

In Myanmar, dry filters are filled with water and left to filter for about 30 minutes before a sample is taken for testing.

Because of the possibility for contamination during the testing procedure, a blank sample (using boiled or bottled water) should be included for every 10-20 samples taken. If the blank sample tests positive for bacteria, there is contamination in the procedure and the results need to be discarded. A positive control with known contamination should also be tested. If the positive control does not show bacterial growth, then either the media is ineffective or the incubation temperature is incorrect or inconsistent, or the source water was not contaminated and the results need to be discarded. In addition, 10% of samples should be duplicated. If results are consistently accurate, fewer duplicates can be tested in subsequent rounds of testing.

Because the concentration of bacteria in a 100 mL sample of challenge water may be too numerous to count, samples will often need to be diluted. Undiluted samples and samples diluted to 1:10 (10 mL of undiluted sample added to 90 mL of sterile water) and 1:100 (1 mL of undiluted sample added to 99 mL of sterile water) should be prepared and tested. The process for diluting samples is explained in detail in the microbiological fact sheet. When using quantitative tests, it is important to always count the bacteria present in the both the challenge water and the filter effluent so that the microbiological efficiency of filters can be measured and compared.

After testing, cultures grown during incubation must be disposed of safely. Bleach should be added to each sample and left for approximately 10 to 15 minutes before pouring the sample with bleach down the drain. The test containers can then be safely disposed of in the normal garbage or sterilized for future use.

## **8.3.6 Additional Testing**

### **8.3.6.1 Heavy Metals and Inorganic Chemicals**

Filter effluent should be tested for heavy metals and inorganic chemicals that could leach into the filtered water. Initially, prototype filters should be tested for all heavy metals and inorganic chemicals. During production, filter effluent should be tested when there is a change in any materials or firing practices, with special attention paid to locally occurring contaminants.

### **8.3.6.2 Arsenic**

Although we do not know the source, arsenic has been detected in the effluent water from filters from some factories (Section 2.1.6). Arsenic testing can be carried out using field test



kits (see Annex J for recommended tests), but it is preferable to take samples to a local laboratory for analysis. Raw or fired clay samples can be tested at an independent laboratory or sent to Vinka Craver for analysis (Annex J). It is important to document the occurrence of arsenic. Though in Myanmar it has not been found to leach from filters in concentrations that would pose a health risk to filter users (Tun 2009), if arsenic is detected in treated water above the WHO provisional guideline value of 0.01 mg/L (WHO 2006), further testing and evaluations will be required. Flushing filters with water may reduce the amount of arsenic to a safe level.

### **8.3.6.3 Silver**

The amount of silver in filter effluent can be measured using a HACH or other brand test kit (Annex J) and should be no more than the WHO guideline value of <0.1 mg/L.

## **8.4 Recommendations**

Based on the knowledge summarized in the previous sections, the following recommendations are made to filter manufacturers by the Working Group:

- 1) Factories are encouraged to carry out internal and/or external reviews after the installation of a new factory, before the initial release of filters for consumer use, and annually.
- 2) Factories are encouraged to obtain certification from the local authorities.
- 3) Factories are encouraged to work with academic researchers, international or local NGOs, health clinics, national health organizations, or other relevant institutions to continue to prove the performance of their filters.
- 4) Production should be well documented to identify changes in materials characteristics, increase efficiency, aid factories in troubleshooting, reduce the risk of having to stop production to resolve a quality control issue, and have manufacturing details available for researchers studying filters.
- 5) Visual inspections should be carried out before each major step of the manufacturing process and observations should be recorded on a filter log.
- 6) Indirect indicator tests including auditory, pressure, and flow rate testing should be carried out and documented for 100% of filters destined for sale or distribution.
- 7) Filters should be saturated before testing their flow rate. Filters that do not meet the minimum flow rate may be refired in attempt to increase the flow rate.
- 8) Flow rate can be determined either by measuring the drop in water level with a T-stick or measuring the water that passes through the filter after one hour. Flat-bottomed filters should be suspended, not placed on their bases.
- 9) The flow rate of each filter should be documented and average flow rates should be monitored over time.
- 10) Each factory should establish a testing schedule for both laboratory and in-house microbiological testing. Filters should be tested after they have passed other quality control tests but before applying silver.
- 11) Routine microbiological testing should be carried out in a laboratory on a minimum of 0.1% of filters. A minimum of a 2-log reduction in TC, TTC, and/or *E. coli* should be achieved.

- 12) Additional testing should be carried out at the factory on a minimum of 1% of filters (minimum one from each batch) using field kits. Results should show either a 2-log reduction or fewer than 10 CFU/100 mL of TC, TTC, and/or *E. coli*.
- 13) Filters that fail any of the quality control tests should be destroyed so they cannot be mistaken for effective filters and used.

## **8.5 Areas for Further Research**

The following areas require further research in order to refine recommendations for best practice in ceramic water filter production:

- 1) How accurately do current indirect testing procedures represent microbiological efficacy?
- 2) How strong is the relationship between flow rate, pore size, and microbiological efficacy?
- 3) Are there additional low-cost indirect performance indicator tests that could be carried out on the filters?
- 4) Improved in-house testing methods that can be used at a factory level need to be developed.

## **8.6 Chapter Details**

The information for this chapter was collated by Mike Stewart. This chapter was edited by Justine Rayner and Daniele Lantagne. Two calls were held on quality control and microbiological testing participants on these conference calls to discuss this chapter included: Robert, Susan, Tracy, Mike, Vinka, Manny, Justine, Lisa, Tracy, Mark, Daniele, and Kaira.

## 9 Variables: The Filter Unit and Packaging

In this chapter, items that make up the complete filtering unit and packaging are presented. These items include the filter element, receptacle, lid, tap, additional items, and O & M instructions. The chapter concludes with a summary of recommendations and a list of areas where further research is needed.

### 9.1 Filters

Filters that have passed all quality control inspections (Section 8.3) and have had silver applied, should be thoroughly dry before packaging. It is recommended that, once dry, each filter be placed in a plastic bag to protect it from dust and dirt.

### 9.2 Receptacle and Lid

The size, shape, and material of the receptacle may depend on local availability and consumer preference.

The size of the receptacle in relation to the size and shape of the filter and pattern of use will influence the volume of water that can be stored and the rate it can be filtered since the flow rate will slow when the water level in the receptacle reaches the bottom of the filter. At a minimum, there should be enough space below the bottom of the filter to hold the volume of water that fits inside the filter, so as not to limit the amount of water that can be filtered over long periods, for example, overnight.

Cam-2 provides a fitting ring that is placed between the receptacle and the rim of the filtering element. This helps to protect the filtering element against damage.

The receptacle can be made from any material that is safe for water storage, including plastic, metal, and ceramic, but not repurposed pesticide containers. Factories currently sell receptacles made from either plastic or ceramic. Colloidal silver, diluted to application strength (Section 7.6), should be applied to the inside of clay receptacles to potentially prevent recontamination and the development of a biological film in the receptacle. Plastic receptacles can be purchased locally. Some factories have a mold made and commission a plastics manufacturer to make their receptacles. Food-grade plastic should be used to manufacture receptacles. Receptacles that can be stacked are convenient for transport.

The hole for the tap should be located as low as possible so that a maximum amount of water can be dispensed, yet high enough that the tap will clear a surface it is set on. Some factories receive their receptacles with the hole for the tap already made. If this is not the case, in a plastic receptacle, the hole can be made either by heating a piece of metal pipe of the same diameter as the tap and using it to melt a hole in the plastic, or by drilling a hole with an appropriately sized drill bit.

The filter should fit in the receptacle so that there are no gaps or spaces near the rim where source water could accidentally be introduced into the filtered water. Some factories provide a fitting ring that protects the filter rim from damage and helps accommodate for slight variation in filter size (Figure 9-1). The receptacle should have a lid with a good enough fit to prevent dirt, dust, debris, and insects from getting into the filter element. Some factories provide lids that are slightly larger than the filter rim and receptacle so that they overhang.

Five factories include a cleaning brush with the filter.

### 9.3 Taps

It is important that taps are of good quality since breakage of the tap is one of the main reasons for discontinuing the use of a filter (Brown and Sobsey 2006). All factories who participated in the survey reported using plastic taps. Some plastic taps have a small ceramic filter inside. Taps that use a metal pin as opposed to a plastic one have been found to be more durable. Some tap suppliers are listed in Annex J.

Cam-1 found metal taps to have a higher failure rate than plastic ones.

### 9.4 Additional Items

Some factories include a fitting ring (Figure 9-1), a scrubbing brush, or an extra tap in the delivery kit. In addition, a locally available cloth that can be used to prefilter the water can be provided for locations with especially turbid water.

### 9.5 Operation and Maintenance (O & M) Instructions

Factories should provide instructional sheets, stickers, and/or have O & M instructions printed on the receptacle during its manufacture. The instructions should include contact information including logo, name, telephone number, and website address if applicable. Examples of O & M instructions are included in Annex K.

Filter manufacturers should recommend that filter owners use the first three flushes of water from the filter to wash the receptacle and tap since the first few batches contain a higher concentration of silver, the receptacle and tap could have become contaminated during transport, and the initial water has a bitter taste, which might discourage filter acceptance.

Scrubbing with a brush is an effective way to remove particles in the surface pores, although internal pores may still remain blocked (van Halem *et al.* 2009). To ensure any microbiological contamination is deactivated, some factories recommend waiting until the filter is dry before setting it up again for use, although this is unproven by evidence and of unknown effectiveness.

Recommendations for cleaning frequency should be “as needed or when the flow rate slows.” Increased handling from frequent cleaning can increase the chances of the filter element breaking, which is often the reason for discontinuing use of the filter (Brown and Sobsey 2006). Frequent cleaning can also increase the chances of contaminating the filter element or receptacle. In Cambodia, it was reported that filters are often cleaned with multi-use cloths and that recontamination through improper handling is a possibility (Brown and Sobsey 2006). Investigations into cleaning practices after measuring an increase in bacteria in filtered water in Peruvian households found that while users followed most cleaning instructions carefully, including the recommended cleaning frequency of the clay filter element of once per month, they cleaned the receptacle 1-2 times per week, thereby increasing the chance of breakage when removing the filter from the receptacle. In addition, over 50% of the households reported “cleaning” their filters with untreated water, many used multi-use rags or cloths to wash and dry the receptacle, and the tap itself was rarely cleaned.



Figure 9-1: Filter Unit with Fitting Ring  
Ceramica Tamakloe, Ghana  
(Source unknown)

Thirty percent did not wash their hands before washing the filter (Dundon 2009). It is therefore important that filter users clearly understand not only how and when to clean the receptacle, tap, and filter element, but also the reasoning behind the process.

Thirst-Aid Myanmar factories ship an extra 5% to accommodate for breakage but have found that fewer than 2% break during transport.

Factories make different recommendations with regards to how long their filters remain effective. Factory recommended lifespan ranges from 1-5 years, unless the filter has cracked or been damaged. The actual lifespan of the filter element has not been determined through research.

Although local context will influence the style, format, and to some extent content, the following should be included in the O & M instructions:

- 1) Wash hands before cleaning the filter.
- 2) Upon receipt of a new filter unit, the first three batches of filtered water should be used to clean the receptacle and tap.
- 3) The filter element, receptacle, lid, and tap should be cleaned when the flow rate slows.
- 4) Upon removing the filter element from the receptacle, it should be placed rim down on the inside surface of the lid.
- 5) The receptacle, tap, and lid should be cleaned when the filter element is cleaned, and not more frequently unless needed. They should be cleaned with a clean sponge or cloth and soap or bleach, and then rinsed with potable (boiled, filtered or chlorinated) water. Clay receptacles coated with silver should not be cleaned with bleach or chlorinated water.
- 6) Only the inside of the filter element should be cleaned and it should be scrubbed with a clean brush and rinsed with potable, boiled, or filtered nonchlorinated water.
- 7) The outside of the ceramic filter element should not be touched during cleaning.
- 8) Soap, bleach, chlorine, or other cleaning agents should not be used on the ceramic filter element.

Because silver is fired into their filters, FilterPure provides different cleaning instructions. They recommend using 1-2 tablespoons of bleach to wash both the receptacle and the element, and they recommend boiling the element for 5 minutes every 3 months.

## 9.6 Packaging

Packaging will vary depending on locally available materials and whether filters are packaged individually or for bulk sale or distribution. All ceramic filtering elements should be packaged in a plastic bag to prevent contamination. If taps are detached from the receptacle for ease of stacking for transport, they should be packaged in a plastic bag and clear instructions on how to attach the tap should be provided or it should be attached by someone properly trained to do so at the destination.

One of the Myanmar factories recently switched their packaging from baskets to cardboard boxes. Although the boxes are easier to stack and NGOs think they look better, they are not as practical because they get soggy when wet and baskets can be reused at the house-hold level.

Factories use a variety of packaging materials. The DR factory reported that popcorn did not prevent breakage, but factories reported success with newspaper, bubble wrap, styro-foam, cardboard separators, and wild grass. Waste material from local industries such as straw, rubber scraps, or shredded paper from a notebook factory can also be used as long as it is not a potential source of contamination.

For individual sale, elements can be packaged directly in the receptacle or in a cardboard box that is the same size as the filtering element. The chance of the filter breaking will be reduced if it cannot move inside the box. Although some factories acquire used boxes, Nica-1 and one factory in Myanmar have their name and logo printed on purchased boxes.

For bulk sale or distribution five or six filters can be packaged together. If filters are stacked, spacers should be used to reduce the risk of cracking and breaking. Filters can be packaged in crates, cardboard boxes, or locally available baskets. Well packaged filters will have enough padding that they do not move inside the container when shaken, if there is movement, they will be more likely to break.



Figure 9-2: Packaged Filters, Myanmar (Thirst-Aid 2009)



Figure 9-3: Packaging Filters, Nicaragua (Rayner 2006)



Figure 9-4: Packaging Filters, Honduras (Hernandez 2009)

## 9.7 Recommendations

Based on the knowledge summarized in the previous sections, the following recommendations are made to filter manufacturers by the Working Group:

- 1) Receptacles should be large enough to hold at least as much water as the filter element before the water level in the receptacle reaches the bottom of the filter.
- 2) Plastic receptacles should be of food grade material and clay receptacles should be coated with colloidal silver diluted to application strength.
- 3) Lids should fit well enough that insects, dust, and debris cannot gain access to the filter or filtered water.
- 4) The tap should be of high quality and located as low as possible to maximize water collection but high enough that it will clear a surface the receptacle is placed on.
- 5) Filter manufacturers should recommend that filter owners wash a new receptacle and tap with the first three flushes of water from the filter because the first few batches of water will contain a higher concentration of silver, the receptacle and tap could have become contaminated during transport, and the initial water has a bitter taste, which might discourage filter acceptance.

- 6) Recommendations for cleaning frequency should be as needed or when flow rate slows.
- 7) The receptacle, tap, and lid should be cleaned when the filtering element is cleaned, and not more frequently, unless needed.
- 8) O & M instructions should be provided with the filter unit and should include the items listed in this section.
- 9) Each filter element should be placed in a bag. Packaging materials and methods that minimize breakage should be used.

## **9.8 Areas for Further Research**

The following areas require further research in order to refine recommendations for best practice in ceramic water filter production:

- 1) How long does the filter element remain effective? What influences the useful life of the filter?
- 2) Are there cleaning methods that can be implemented at a household level to help unclog pores deep within the filter structure?

## **9.9 Chapter Details**

The information for this chapter was collated by Justine Rayner and edited by Daniele Lantagne.

## 10 Conclusions

The objective of this project is to provide consensus-based guidelines for local manufacturing of ceramic water filters. We have worked towards this objective by: 1) forming the Ceramics Manufacturing Working Group; 2) holding conference calls to discuss topics in production; 3) identifying operating filter factories; 4) surveying and documenting existing practice in manufacturing; 5) summarizing knowledge on how filters work; 6) making best practice recommendations; and, 7) identifying areas where further research is needed.

This ceramic water filter technology was designed to be manufactured by artisans and to accommodate variation in methods and materials. Filters are currently being produced at 35 independently run factories in 18 countries. Each factory is limited by locally available materials, equipment, and resources. This results in inevitable variation in production. Variations in production occur not only between factories in different countries, but also within each factory. One of the challenges of standardizing the production process is bridging the art of working with clay, a highly intuitive process, with the manufacturing of a reliably effective health tool. Factories adjust their production practices according to their experience, continually trying to improve upon their production process and end product.

Despite the tolerance for variation, there are aspects of production that are important to control in order to consistently manufacture a product of sufficient quality that it can be used as a public health intervention to improve the microbiological quality of water and reduce diarrheal disease. Further research is required in many areas as the relationships between and the effects of variables are many and are not clear or well understood.

Despite these limitations, we have worked as a group to define best practice recommendations for ceramic water filter manufacturing. We have included theory and reasoning behind our recommendations as we hope this information will help factories make manufacturing decisions within the context of their circumstances. It is important that filter quality is evaluated and verified following any change in materials or production. Thorough documentation of materials and daily production will allow factories to monitor and evaluate changes and trace back how each filter was produced. We encourage factories to produce consistent filters through consistent manufacturing methods and establish a quality control program that routinely verifies the quality of the filters they produce.

In the following sections, information from discussions and research has been summarized into: 1) lessons learned; 2) manufacturing recommendations; and, 3) recommended research.

### 10.1 Lessons Learned

The results of the literature review and filter factory survey suggest seven key lessons learned: 1) little is known about how the many variables in filter production influence filter characteristics and quality; 2) production practices are not consistent and are not well documented; 3) guidelines for diluting silver are needed; 4) microbiological testing needs to be carried out regularly on a minimum number of filters; 5) flow rate testing procedures are not standardized; 6) health and safety precautions need to be enforced; and, 7) factories could benefit from sharing experiences. Each of these lessons is discussed below.



### **10.1.1 Little is known about how the many variables in filter production influence filter characteristics and quality.**

The goal is to create a filter element that improves the microbiological quality of water. Mechanisms that aid in improving water quality are affected by characteristics such as pore size, pore size distribution, porosity, and hydraulic conductivity. These, in turn, are affected by several aspects of the manufacturing process including materials characteristics, how materials interact with each other, materials processing, mixing, pressing and drying, and the firing schedule. Few studies have characterized the effects and relationships of the many variables involved in filter production (Figure 3-1). Additional research is needed in many areas in order to refine recommendations for best practice.

### **10.1.2 Production practices are not consistent and are not well documented.**

Variations in filter production occur both within and between factories, and filters produced in different factories have been found to have different characteristics. Although some variation in daily production might be inevitable, the documentation and analysis of production can encourage consistency in manufacturing and aid in identifying causes of inconsistencies. In addition, investigations into filter characteristics and filter effectiveness could benefit from having production details available.

### **10.1.3 Guidelines for diluting silver are needed.**

During the survey, respondents found it difficult to answer questions regarding the amount and concentration of silver applied to filters. Based on the information reported, silver application is not consistent. Clear information about silver concentration and corresponding dilution guidelines needs to be available to the factories. Further research regarding the effects of different types of silver, different application methods, and different silver concentrations on the efficacy of the filters is needed.

### **10.1.4 Microbiological testing needs to be carried out regularly on a minimum number of filters.**

Factories provided little information regarding which microbiological tests are carried out, which indicator bacteria are used, and the results of tests. Microbiological testing of filters is not consistent between factories: eight factories reported testing 0.2%-15% of their filters regularly. Therefore, guidelines on the percentage of filters that should be tested, the frequency of testing, what should be tested for, and the expectations for filter performance should be outlined and made available to factories. The availability of a local, certified laboratory will vary with factory location so in-house testing, including training, should be implemented to compliment laboratory and third-party testing. Options for in-house testing methods should be made known to the factories.

### **10.1.5 Flow rate testing procedures are not standardized.**

Flow rate testing is used as a primary indicator of filter quality; however, factories do not follow a standard procedure. Lantagne (2001a) noted that to obtain consistent results it is important to soak filters until saturated before testing their flow rate. Nederstigt and Lam found that the flow rate of filters became consistent after a 24-hour soaking period (van Halem 2006). Only five filter factories soak their filters for 24 hours before flow rate testing them and three factories do not soak their filters at all. Although the soaking time required to achieve saturation may vary from factory to factory, it is important that filters are saturated

before flow rate testing to ensure consistent flow rate measurements. Filter characteristics such as capacity, surface area, and wall thickness should be considered when establishing acceptable flow rates.

#### **10.1.6 Health and safety precautions need to be enforced.**

Health and safety risks can include both injuries and long-term health risks. Four factories reported minor injuries to hands and fingers. Although no factories reported back injuries, the use of proper lifting techniques and ergonomic work conditions are important to minimize such risks. Although all factories reported that workers use dust masks or some sort of nose and mouth covering while processing raw materials, these precautions are not strictly enforced or adhered to—only eight factories reported that their employees always wear facemasks while processing raw materials. In order to reduce occupational health risks such as silicosis, which is a serious health risk associated with long-term exposure to clay dust, information about health risks needs to be available to factory managers and employees and the use of appropriate preventative measures needs to be enforced.

#### **10.1.7 Factories could benefit from sharing experiences.**

During the survey, factories were asked about current and previous challenges, solutions, and what they have tried in the past that did not work. The length of the survey likely influenced the amount of detail some participants provided. Although what works at one factory might not work at another, many participants expressed curiosity about the experiences at other factories and many were interested in sharing their experiences with others.

### **10.2 Summary of Best Practice Recommendations**

The following summary of recommendations to filter manufacturers is based on the knowledge summarized in this report.

- 1) **FACTORY SETUP:** Before establishing a factory, it is recommended that a production manager visit a fully functioning filter factory. An experienced filter technician and local potters should be involved when setting up a factory and developing the mixture ratio.
- 2) **WATER:** A reliable source of reasonably clean water is required for filter manufacturing. Both production and flow rate testing water should be tested for heavy metals, inorganic chemicals, arsenic, and microbiological contaminants at project outset and yearly, or more regularly if the factory is using an intermittent or less safe source. In addition, flow rate testing water should be evaluated for turbidity.
- 3) **RAW MATERIALS:** A reliable source for raw materials, including clay, burn-out materials, and any additional materials added to the filter mixture should be identified and materials should be evaluated during initial sourcing, yearly, when characteristics vary, or if a change in filter quality is observed. Evaluations should be documented and analyzed, and a variation greater than 10% or a change in filter characteristics or quality must be followed-up with microbiological confirmation of filter effectiveness.
- 4) **MATERIALS PROCESSING:** Both clay and burn-out material should be processed onsite to a consistent powdered form using a 25 or 30 mesh sieve. Additional materials, such as sand, grog, or laterite, should be processed and included

consistently according to the factory filter mixture ratio. Both raw and processed materials should be stored safely and under appropriate conditions.

- 5) **ESTABLISHING RATIO:** The appropriate clay:burn-out ratio should be determined at project outset, and used consistently throughout production and any changes in ratio should be confirmed with microbiological testing of finished filters. To confirm clay:burn-out ratio, a minimum of 9 prototype filters from 3 different batches should be tested and achieve 99% (2-log) reduction of microbiological indicators. The effluent water from prototype filters should be tested for heavy metals and inorganic chemicals before starting production.
- 6) **MIXTURE PREPARATION:** In preparing the filter mixture, raw materials should be measured by weight, not volume, and the burn-out material should be dehydrated before it is weighed. Materials should be mixed in a mortar mixer operating at 40-50 rpms, if available. Before adding water, mixed dry materials should be inspected visually for even distribution of clay and burn-out material and again after water has been added. The mixture should be processed through a pug mill, if available. Filter mixture should be wedged or kneaded before pressing. A standard weight of filter mixture should be used to press each filter. Filters should be pressed the same day that the filter material is prepared, and filters manufactured from the same batch of filter mixture should be kept together throughout production and fired in the same kiln load.
- 7) **FILTER PRESSING AND DRYING:** A press with a high-quality mold should be used to press the filter mixture into shape. Freshly pressed filters should be handled as little as possible to prevent deformation or warping. Filters should be stored in conditions that allow them to dry slowly and evenly, protected from direct sun, wind, and rain. Artificial drying from a wet stage is not recommended. Once leather-hard, the surface of the filter may be touched up and each filter should be stamped with a batch, filter number, and logo. Filters should be inspected visually after pressing and periodically throughout the drying process for even drying, deformation, and cracks, holes or other flaws. Once beyond the leather-hard stage, filters should never be patched: rejected filters should be destroyed, and the mixture should not be reused to make filters.
- 8) **KILNS:** The Mani kiln is recommended for filter production, but other fuel efficient, reliable kilns that fire evenly and consistently may be used. Kiln capacity should be tailored to the projected level of production taking into consideration mixture batch size, daily production capacity, and factory storage capacity. Production can be smoothly coordinated if kiln capacity matches the number of filters that will be produced in 2 days, so that a production run can be fired in one firing and time is allowed for the firing and cooling of the kiln(s). Kiln temperature mapping should be carried out on a new kiln, annually, or if firing results (filter quality) are inconsistent. Effort should be made to acquire fuel from sustainable sources. Experimentation with and the use of agricultural waste or alternative fuel sources is encouraged.
- 9) **FIRING:** Filters should be completely dry before being fired and should be stacked using spacers to promote heat circulation and even heating and cooling to reduce the chances of warping or cracking and minimize carbon marks on the filters. The firing temperature and firing curve appropriate for the local clay and burn-out material should be established and followed, and a firing log should be maintained. To ensure

processes are properly carried out, firing should be slow and closely monitored during the critical phases of water smoking, combustion of the burn-out material, and burning out of carbon. Fewer than 10% of filters should crack per firing. It is not recommended that a black core be allowed to remain within filter walls. Kiln temperature and heatwork should be monitored visually, with pyrometric cones (the three cone method), draw trials, and a pyrometer with thermocouples. The use of these methods will help monitor heat distribution in the kiln, aid in consistent firings, and provide information to document and compare firings, aid in troubleshooting, and help increase fuel efficiency.

- 10) **HEALTH AND SAFETY:** Employees should be required to follow national and local health and safety regulations in addition to the guidelines outlined in each section of this report. In particular, anyone exposed to airborne particles should be required to wear face masks, remembering that very fine silica dust can remain airborne for several hours. In addition, preventative measures should be taken to reduce the suspension of dust including cleaning with water (as opposed to dry sweeping) and securing the collection bag to the hammermill during operation. Wearing goggles can prevent eye irritation from dust. When working with machinery, long hair should be tied back, and loose clothing, which could get caught, should not be worn. Earplugs should be worn when working with or near loud machinery. When looking into a hot kiln safety goggles that protect from ultraviolet and infrared light should be worn. When working with liquid silver, gloves and an apron should be worn and when working with powdered silver, a face mask, protective eyewear, gloves, and an apron should be worn.
- 11) **DOCUMENTATION:** Materials evaluations, production, and firing logs should be maintained. Materials should be evaluated regularly. A detailed production log that documents the manufacturing process and the results of quality control evaluations and tests should be maintained for each filter. A firing log should be kept to document each firing and the location of each filter in the kiln should be recorded. Recommended items to record are suggested throughout this report and example logs are included in Annex G.
- 12) **INSPECTING AND TESTING FILTERS:** Visual inspections should be carried out before each major step of the manufacturing process, observations should be recorded on a filter log, and filters which do not pass should be destroyed. Indirect indicator tests including auditory, pressure, and flow rate testing should be carried out and documented for 100% of filters destined for sale or distribution. Filters should be saturated before testing their flow rate. Flow rate can be determined either by measuring the drop in water level with a T-stick or measuring the water that passes through a suspended filter after 1-hour. Filters that do not meet the minimum flow rate may be refired in attempt to increase the flow rate. The flow rate of each filter should be documented and average flow rates should be monitored over time.
- 13) **MICROBIOLOGICAL TESTING:** Each factory should establish a microbiological testing schedule that includes both independent laboratory testing and in-house testing. Microbiological testing should be carried out before silver application. A minimum of 0.1% of the filters should be tested in a laboratory. A minimum of a 2-log reduction in TC, TTC, and/or *E. coli* should be achieved. Additional testing should be

carried out at the factory on a minimum of 1% of filters (minimum one from each batch). Results should show either a 2-log reduction or fewer than 10 CFU/100 mL of TC, TTC, and/or *E. coli*. Filters that do not pass quality control tests should be destroyed so they cannot be mistaken for effective filters and used.

- 14) SILVER APPLICATION: Colloidal silver should be applied to filters to prevent bacterial growth in the filter (Silversty-Rodriguez 2008) and potentially increase the microbiological reduction through the filter. Silver should be applied to filters that have passed all other quality control inspections to avoid wasting silver on noncompliant filters and reduce the amount of silver released into the environment. Colloidal silver should be diluted with nonchlorinated boiled, filtered, bottled or deionized water, preferably with a low calcium concentration (to prevent the aggregation of silver particles). Approximately 64 mg of colloidal silver should be applied to each filter by brushing on 302 mg of a 211 ppm solution. Powdered, liquid, and diluted silver should be stored in a dark, airtight container to protect it from oxidation and ultra-violet light. Because there are potential problems with dissociation of silver nitrate from the filter, the use of silver nitrate is not recommended until further research has been carried out.
- 15) THE FILTER UNIT AND PACKAGING: Receptacles should be large enough to provide enough space below the bottom of the filter to contain the volume of water that fits inside the filter. Lids should fit well so that insects, dust, and debris cannot gain access to the filter or filtered water. The tap should be of high quality and located to maximize the amount of water that can be dispensed yet clear a surface the receptacle is placed on. Plastic receptacles should be made of food grade material and clay receptacles should be coated with colloidal silver diluted to application strength. Filter elements should be placed in a bag. Packaging of filter units should be developed to minimize breakage.
- 16) OPERATION AND MAINTENANCE INSTRUCTIONS: Filter manufacturers should recommend that filter owners wash the receptacle and tap with the first three flushes of water from the filter since: 1) the first few batches contain a higher concentration of silver; 2) the receptacle and tap could have become contaminated during transport; and, 3) the initial water has a bitter taste, which might discourage filter acceptance. Operation and maintenance instructions should be provided with each filter unit and should state: cleaning frequency should be as needed or when flow rate slows; the receptacle, tap, and lid should be cleaned when the filtering element is cleaned, and not more frequently, unless needed; hands should be washed before cleaning the filter; once removed from the receptacle, the filter element can be placed rim down on the inside of the lid; the receptacle, tap, and lid can be cleaned with bleach or soap (except clay receptacles); and, cleaning products should not be used on the filter element and only the inside of the element should be cleaned and scrubbed, the outside should not be touched.
- 17) ONGOING EVALUATIONS: Factories are encouraged to obtain certification from local authorities and carry out internal and/or external reviews after the installation of a new factory, before the initial release of filters for consumer use, and annually. Factories are encouraged to work with academic researchers, international or local NGOs, health clinics, national health organizations, or other relevant institutions to continue to prove the performance of their filters. Production should be well documented to aid factories

in troubleshooting, identify changes in materials characteristics, increase efficiency, reduce the risk of having to stop production to resolve a quality control issue, and to have manufacturing details available for researchers studying filters.

### **10.3 Summary of Areas for Further Research**

The following is a summary of areas that require further research in order to refine the recommendations for best practice in ceramic water filter production:

- 1) **CHEMICAL CONTAMINANTS:** Further research is needed to understand the effects of arsenic, fluoride, chlorine, and other inorganic contaminants in the water or other raw materials used to manufacture filters on the quality of filtered water. The possibility of altering firing practices in order to eliminate or reduce any negative impacts identified should also be investigated.
- 2) **VIRAL CONTAMINANTS:** Investigations into possible additives or coatings that could make filters effective against viruses are needed. A method of identifying local sources of these additives or coatings and processing requirements are needed.
- 3) **CLAY CHARACTERISTICS:** Research is needed into the effects of different types of clay microstructures on fired filter strength, as well as how these microstructures can be evaluated and influenced on a local level. The influence of clay characteristics on the filter mixture ratio needs to be investigated. The effects on filter performance of using unfired commercial bricks or failed, unfired filters in the filter mixture need to be evaluated.
- 4) **BURN-OUT CHARACTERISTICS:** Further investigation is needed into how different burn-out materials (such as sawdust, rice husks, or peanut shells) influence filter performance, including the workability of the mixture, flow rate, appropriate clay:burn-out ratio, whether some burn-out materials leave a residue in the filter, and microbiological efficacy. Further research is needed into whether variation within a given type of burn-out material (such as using sawdust from different types of trees or using different parts of the rice husks) affects the flow rate, clay:burn-out ratio, or microbiological efficacy. Little is understood about the role burn-out material particle size plays in pore structure and hydraulic properties. An acceptable range of clay:burn-out ratio to achieve optimal flow rate and microbiological effectiveness needs to be evaluated for each burn-out material. It would be useful to identify optimum firing profiles that accomplish complete combustion of each type of burn-out material.
- 5) **MIXTURE PROCESSING:** It is unknown whether storing prepared filter mixture before pressing affects filter characteristics and performance. For example, does the sawdust absorb moisture and expand during storage, and are pore sizes and resulting filtration rates affected by this? Also, does the storage of filter mixture affect the plasticity of the mixture? Also untested, is whether dried, unfired filters can be pulverized, screened, and reprocessed into future batches of filter mixture without compromising quality, and if so, what is the practical limit of recycled material that can be included in the filter mixture? The identification of a visual indicator that can be added in the mixture without affecting filter effectiveness would aid in determining when dry mixing is complete.

- 6) **ADDITIONAL PROCESS VARIABLES:** Process variables that can affect the pore structure and fired filter strength, such as the use of a pug mill in processing the mixture or the amount of pressure applied in the pressing process, need to be identified. Research is needed to confirm that the use of different oils as a mold release does not affect the firing or leave a residue in the finished filter.
- 7) **FILTER SHAPE:** Further Investigation is required into the advantages and disadvantages of each of the three filter shapes and how other filter characteristics such as diameter, depth, volume, and wall thickness affect filter strength, hydraulic properties, and biological effectiveness. Is there an optimal design for filter size and shape for different circumstances?
- 8) **FIRING VARIABLES:** It is currently unclear whether heating schedule and peak temperature could neutralize arsenic, heavy metals, or other inorganic materials that occur naturally in some clay sources, possibly by melting them into the fired clay matrix. Also unknown is whether a fuel source could contribute towards contaminating filters. Research needs to be carried out on the effects on the efficacy and lifespan of the filter of leaving a black core within the filter walls, and on how the thickness of the black core can be monitored or controlled. Ways of improving efficiency and reducing the cost of firing, perhaps by using alternative fuels, and whether there is potential for a low-cost system for recycling energy from heat exiting the chimney, could be investigated.
- 9) **SILVER APPLICATION:** Research is needed to determine the optimum amount of silver required to achieve the desired bactericidal effectiveness taking into consideration the quantity of silver that leaches into effluent water, and the safety of workers applying the silver. The amount and rate of silver leaching over time needs to be quantified since it has implications for user consumption of silver, the bactericidal effectiveness of the filter, and the projected useful life of the filter. How source water quality and characteristics, such as ionic salt concentration which is typically higher in groundwater than in surface water, affect silver effectiveness and leaching rates needs to be evaluated. Research is needed to determine whether silver nitrate is an acceptable substitute for colloidal silver and under which circumstances each type of silver may be appropriate. The effectiveness of silver nitrate as a disinfectant needs to be evaluated. Its ability to bond with the clay matrix, how it disassociates from the filter, and potential worker health risks associated with its use, need to be determined. The nature of the silver-chlorine interaction needs to be investigated: it remains unknown whether chlorine compromises or improves upon the bactericidal effectiveness of silver. Also unknown are the effects of filtering chlorinated water and washing filters with bleach.
- 10) **TESTING PROCEDURES:** The strength of the relationship between flow rate, pore size, and microbiological efficacy needs to be evaluated to determine whether current indirect testing procedures correlate with microbiological efficacy. Additional low-cost indirect performance tests, which could be carried out on the filters, need to be developed along with improved in-house microbiological testing methods that can be implemented by individual factories. Standard water quality parameters for influent water used in disinfection testing also need to be defined.

- 11) FILTER LIFESPAN: Research into the variables that influence filter lifespan can help develop evidence-based guidelines for manufacturer lifespan recommendations. Investigations are needed into the development of improved cleaning methods that will unclog pores deep within the filter structure.

#### **10.4 Voluntary Nature of Recommendations**

The members of the Ceramics Manufacturing Working Group have discussed whether the recommendations outlined in this report should be voluntary or enforced. The group also discussed the logistics associated with establishing a quality assurance program, including the possibility of quality certification. Currently, no board exists to inspect, oversee, or certify production at the different facilities, although some individuals and organizations hope to see this develop in the future. At the moment we believe that filter factories are interested in producing quality filters that improve the microbiological quality of water and will voluntarily implement improvements based on the theory and guidelines presented in this report.

In conclusion, we encourage factories and organizations to report whether they are adhering to the recommendations in these guidelines, fully or in part, and/or how they have adapted them to meet the needs of their facility. In addition, we invite any interested parties to participate in revisions of these guidelines over time. At this point, no one in the group plans to act as an enforcer, regulator, or certifier of these guidelines. We see this document, much like *Minimum Standards in Disaster Response* published by The Sphere Project, as a document which shares the best information we have at this time to define best practice in ceramic water filter manufacturing. We look forward to revising this document over time, as new information and research becomes available.



# 11 Glossary

**Colloidal silver (also, silver nanoparticles or nanosilver)** A fine particle of metallic silver that has at least one dimension lower than 100 nanometers (or 0.1 millionth of a meter). Nanosilver particles exhibit physical properties that are different from both the ion and the bulk material.

**Cones** See Pyrometric cones.

**Downdraft kiln** A kiln that does not have an opening in the roof. When the heat reaches the roof it is directed downwards into an opening in the kiln floor that directs it into the chimney.

**Dunt** A crack that occurs in pottery as a result of the stress caused by the sudden expansion or contraction that occurs during the silica inversion, when the lattice structure of silica rearranges itself during heating or cooling.

**Flow rate** The amount of water that passes through a full, saturated filter after a specific period of time, typically 1 hour.

**Flux** An oxide that promotes ceramic fusion by lowering the melting temperature of the clay body.

**Goethite** See Laterite.

**Greenware** Clay that has been formed or shaped but has not yet been fired.

**Grog** Previously fired ceramic material that has been ground into a powder and screened for consistent size; it is added to a clay body to reduce plasticity, aid in even drying, and reduce shrinkage.

**Heatwork** A term used to describe the effects of both time and temperature on clay.

**Hydraulic conductivity** The rate water can move through a medium, for example, the filter walls.

**Ionic silver** A form of silver obtained when a silver salt, such as silver nitrate, is dissolved in water. The solution is transparent, consists of water and single-atom silver ions (dissolved silver), and contains no silver particles.

**Kelvin** A unit of measurement for temperature. The Kelvin scale starts at a theoretical absolute zero which is 273.15°C below the freezing temperature of water (0 kelvin = -273.15°C).

**Laterite** A soil layer consisting of several minerals including goethite, an iron oxide. Laterite is sometimes included in filter mixture as it is thought to provide additional viral binding sites. It also increases the flow rate and the weight of filters.

**Leather-hard** A term used to describe clay that has dried to the point that the clay particles are touching. It can be handled without distortion, yet it is still soft enough that it can be worked on.

**Lime popping** If there is lime in raw clay, after it has been fired, the lime slowly absorbs moisture from the air (calcium hydroxide). This causes it to expand, and results in a section of the body popping off, leaving a half-moon shaped crack in the fired clay body. The size of the lime particle, as opposed to the presence of it, results in lime popping. Lime popping has not been reported in filters.

**Log Reduction Value (LRV)** Used to express the microbial removal efficiency by factors of 10; the log of 10 equals 1, the log of 2 equals 100, etc. It can easily be converted to percent reduction: a 1-log reduction is 90%, 2-log 99%, and 3-log is 99.9%.

**Mani Kiln** A downdraft kiln designed by Manny Hernandez specifically for filter production. The flat top design was inspired by the Minnesota flat-top kiln. It actually has a domed roof.

**Mesh** A screen or sieve used to control the particle size of a material, the size of the openings determine the size of the particle that can pass through the sieve. Mesh numbers are not standardized internationally. In this document the Tyler Mesh Equivalent is used: the mesh number represents the number of threads or openings per linear inch of a screen or sieve.

**Maturation range** The temperature range during which a clay body reaches the desired strength and compactness through vitrification. Below this range, the body will be under-fired (weak and very porous) and above this range it will be over-fired (possibly deformed and brittle). The maturation range varies for each clay.

**Plasticity** A property held by clay that allows it to be deformed or shaped, and hold its shape. Plasticity, the ability of clay particles to slide, is influenced by particle size, purity, moisture content, particle uniformity, plasticizers, and strength of particle bond. Clay lacking in plasticity is often referred to as “short”.

**Porosity** The volume of void spaces in a material, expressed as percent porosity.

**Pug mill** A machine used to mix and compress wet clay. It helps create a homogeneous mixture and improves strength. It reduces, but does not eliminate, the need for kneading and wedging.

**Pyrometer** A device used to measure the ambient temperature within the kiln. Information is transmitted by wire to the pyrometer from a thermocouple, a device inserted through the kiln wall that heats up inside the kiln; the pyrometer reads the temperature of the tip of the thermocouple.

**Pyrometric cones** Cone-shaped devices made from a specific formulae of refractory and fluxing materials and used to measure the effects of both time and temperature, known as “heatwork.” Cones are numbered and different-numbered cones are designed to bend, or deform at specific temperatures. Cones range from low (cone 022) to high temperatures (cone 14). Correlating temperatures vary across manufacturers.

**Short clay** A clay is considered “short” when it has low plasticity, either because it has a predominantly large particle size or because it contains a large proportion of non-plastic material. This results in more friction between particles, giving the clay a “bouncy” feel. Because of the friction between particles short clay tends to resist shaping, will break apart more easily, and typically is not as strong.

**Silica inversion** Occurs when the lattice structure of silica in the clay rearranges itself, resulting in a sudden expansion on heating or contraction on cooling accompanied by a change in size that can cause cracking, or dunting, in pottery. Two important inversion temperatures are the quartz inversion which occurs around 573°C (1,063°F) and the cristobalite inversion which occurs around 226°C (439°F). The cristobalite inversion is of concern only if a significant amount of quartz has converted to cristobalite, which starts to occur at temperatures above 1,100°C (2,012°F).

**Soak** When the kiln temperature is held constant for a period of time.

**Thermocouple** See Pyrometer

**Tortuosity** Describes the path water takes through the filter walls. A more tortuous filter material will have a more winding or twisting path with bends and turns, increasing the distance water must travel to exit the filter.

**Updraft kiln** A kiln in which the heat flows up through the wares and exits through opening(s) at the top; though some updraft kilns have a chimney, it is not required.

**Vitrification** The process during firing when clay particles are welded together by glass. As the glass forms it begins to fill the void spaces. Therefore as ceramic vitrifies, it loses porosity. Earthenware clays tend to deform before losing much porosity to vitrification. Vitrification begins around 800°C (1,472°F).

**Wedging** Working clay to homogenise the material and remove air bubbles; it is sometimes compared to kneading bread dough, although kneading bread dough is designed to add air to the mixture.

## 12 References

- AFA (1995) *Contra la morbilidad infantil: Filtros artesanales y educación*. Instituto de Investigaciones Económicas y sociales (IDIES): Guatemala.
- Archer, S.L. (2008) Dilated cardiomyopathy and left bundle branch block associated with ingestion of colloidal gold and silver is reversed by British antiLewisite and vitamin E: the potential toxicity of metals used as health supplements. *Canadian Journal of Cardiology* 24(5): 397-399.
- Asopafin (2009). Colombia: Photograph provided by Asopafin, Colombia in response to questionnaire.
- AZoM (2009) <http://www.azom.com/details.asp?ArticleID=1417>. (Accessed 2009).
- Bielefeldt, A.R., Kowalski, K. and Summers, R.S. (2009) (In Press) Bacterial treatment effectiveness of point-of-use ceramic water filters. *Water Research* (2009) doi: 10.1016/j.watres.2009.04.047.
- Bloem, S.C., van Halem, D., Sampson, M.L., Huoy, L.S. and Heijman, B. (2009) *Silver Impregnated Ceramic Pot Filter: Flow Rate versus the Removal Efficiency of Pathogens*. International Ceramic Pot Filter Workshop. Atlanta, GA, USA.
- Boschi-Pinto, C., Velebit, L. and Shibuya, K. (2008) Estimating child mortality due to diarrhoea in developing countries. *Bull World Health Organ* 86(9): 710-717.
- Brown, J. (2007) *Effectiveness of ceramic filtration for drinking water treatment in Cambodia*. Unpublished Thesis, University of North Carolina.
- Brown, J. and Sobsey, M. (2006) *Independent Appraisal of Ceramic Water Filtration Interventions in Cambodia*. Submitted to UNICEF:
- Brown, J., Sobsey, M. and Proum, S. (2007) *Use of Ceramic Water Filters in Cambodia*. Water and Sanitation Program/UNICEF: Cambodia.
- Brown, J. and Sobsey, M.D. (2009) Ceramic media amended with metal oxide for the capture of viruses in drinking water. *Environmental Technology* 30(4): 379-391.
- Brown, J., Sobsey, M.D. and Loomis, D. (2008) Local drinking water filters reduce diarrheal disease in Cambodia: a randomized, controlled trial of the ceramic water purifier. *Am J Trop Med Hyg* 79(3): 394-400.
- Campbell, E. (2005) *Study on Life Span of Ceramic Filter Colloidal Silver Pot Shaped (CSP) Model*. Managua, Nicaragua.
- CeramicArtsDaily (2010) *2010 Workshop Handbook*, Ceramic Publications Company.
- Chartrand, P. (2010) Personal Communication (with J. Rayner).
- Chartrand, P. (2011): Photograph provided by Peter Chartrand.
- Chen, X. and Schluesener, H.J. (2008) Nanosilver: A nanoparticle in medical application. *Toxicology Letters* 176: 1-12.
- Cho, K., Park, J., Osaka, T. and Park, S. (2005) The study of antimicrobial activity and preservative effects of nanosilver ingredient. *Electrochimica Acta*: 956-960.

- Clasen, T. and Bastable, A. (2003) Faecal contamination of drinking water during collection and household storage: the need to extend protection to the point of use. *J Water Health* 1(3): 109-15.
- Cohen, B. (2010a): Photographs provided by Burt Cohen.
- Cohen, B. (2010b) Personal Communication (with J. Rayner).
- Cuff, Y.H. (1996) *Ceramic Technology for Potters and Sculptors*. A & C Black (Publishers) Limited: London.
- Danilczuk, M., Lund, A., Saldo, J., Yamada, H. and Michalik, J. (2006) Conduction electron spin resonance of small silver particles. *Spectrochimica Acta Part A* 63: 189-191.
- Desmyter, D., Adagwine, A.P., Ibrahim, S., Jaackson, M.K. and Murcott, S.E. (2009) *Monitoring and Evaluation of 1,000 Households receiving Ceramic Pot (Kosim) Filters after an Emergency Flood Mass Distribution in Northern Ghana*. WEF09. Atlanta.
- Drake, P.L. and Hazelwood, K.J. (2005) Exposure-Related Health Effects of Silver and Silver Compounds: A Review. *Annals of Occupational Hygiene* 49: 575-585.
- Dubas, S., Kumlangdudsana, P. and Potiyaraj, P. (2006) Layer-by-layer deposition of antimicrobial silver nanoparticles on textile fibers. *Colloids and Surfaces A: Physicochemical and Engineering Aspects* 289: 105.
- Dundon, S.M. (2009) *Use and Effectiveness of Potters for Peace Ceramic Water Filter in a Peri-Urban Slum in Lima, Peru*. HWTS09. RCSI, Dublin, Ireland.
- Elechiguerra, J.L., Burt, J.L., Morone, J.R., Camacho-Bragado, A., Gao, X., Lara, H.H. and Yacaman, M.J. (2005) Interaction of silver nanoparticles with HIV-1. *Journal of Nanobiotechnology* 3(6): 1-10.
- Fahlin, C.J. (2003) *Hydraulic Properties Investigation of the Potters For Peace Colloidal Silver Impregnated, Ceramic Filter*. Unpublished Thesis, University of Colorado at Boulder, Boulder, CO, USA.
- Fauss, E. (2008) *Silver Nanotechnology Commercial Inventory Analysis*. Unpublished Work. Woodrow Wilson International Center for Scholars.
- Feng, Q.L., Wu, J., Chen, G.Q., Cui, F.Z., Kim, T.N. and Kim, J.O. (2000) A mechanistic study of the antibacterial effect of silver ions on *Escherichia coli* and *Staphylococcus aureus*. *Journal of Biomedical Materials Research* 54: 662-668.
- FilterPure (2009). Dominican Republic: Photograph provided by FilterPure in response to questionnaire.
- Furno, F., Morley, K.S., Wong, B., Sharp, B.L., Arnold, P.L., Howdle, S.M., Bayston, R., Brown, P.D., Winship, P.D. and Reid, H.J. (2004) Silver nanoparticle and polymeric medical devices: a new approach to prevention infection? *Journal of Antimicrobial Chemotherapy* 54(1019-1024).
- Hagan, J.M., Harley, N., Pointing, D., Sampson, M., Smith, K. and Soam, V. (2009) *Resource Development International - Cambodia Ceramic Water Filter Handbook-, Version 1.1*. Phnom Penh, Cambodia.
- Hamer, F. and Hamer, J. (2004) *The Potter's Dictionary of Materials and Techniques*. A&C Black Publishers Ltd: London.

- Heinig, C.F. (1993) O<sub>3</sub> or O<sub>2</sub> and Ag: A new catalyst technology for aqueous phase sanitation. *Ozone Science & Engineering* 15: 533-546.
- Hernandez, M. (2006) *Kiln Building*. ETHOS Conference Presentation. Kirkland, WA, USA.
- Hernandez, M. (2007) *Firing the Mani Kiln*. Unpublished
- Hernandez, M. (2009). Professor of Art. Northern Illinois University: Illustrations and photographs provided by Manny Hernandez.
- Hernandez, M. (2010): Photographs provided by Manny Hernandez.
- Hussain, S., Hess, K., Gearhard, J., Geiss, K. and Schlager, J. (2005) In vitro toxicity of nanoparticles in BRL 3A rat liver cells. *Toxicology in Vitro* 19: 975.
- IDECambodia (2009): Photographs provided by IDE Cambodia in response to the questionnaire.
- Jain, P. and Pradeep, T. (2005) Potential of silver nanoparticle-coated polyurethane foam as an antibacterial water filter. *Biotechnology and Bioengineering* 90(1): 59-63.
- Jeong, J., Kim, J.Y. and Yoon, J. (2006) The role of reactive oxygen species in the electrochemical inactivation of microorganisms. *Environmental Science and Technology* 40: 6117-6122.
- Johnson, S.M., Peletz, R.L. and Murcott, S. (2008) *Results from household ceramic filter evaluation in northern Ghana*. Access to Sanitation and Safe Water: Global Partnerships and Local Actions. 33rd WEDC International Conference, Accra, Ghana.
- Kallmand, E., Oyanedel-Craver, V., and Smith J. (2010) Ceramic Filters Impregnated with Silver Nanoparticles for Point-of-Use Water Treatment in Rural Guatemala. *Journal of Environmental Engineering (accepted)*.
- Kim, J.S., Kuk, E., Yu, K.N., Kim, J.-H., Park, S.J., Lee, H.J., Kim, S.H., Park, Y.K., Park, Y.H., Hwang, C.-Y., Kim, Y.-K., Lee, Y.-S., Jeong, D.H. and Cho, M.-H. (2007) Antimicrobial effects of silver nanoparticles. *Nanomedicine: Nanotechnology, Biology, and Medicine* 3: 95-101.
- Klarman, M. (2009) *Investigation of Ceramic Pot Filter Design Variables*. Unpublished Thesis, Emory University, Rollins School of Public Health, USA.
- Lantagne, D. (2006) *Potters for Peace: Filter Production Facility Best Practices*. Potters for Peace: Managua, Nicaragua.
- Lantagne, D., Klarman, M., Mayer, A., Preston, K., Napotnik, J. and Jellison, K. (2009) Effect of production variables on microbiological removal in locally-produced ceramic filters for household water treatment. *International Journal of Environmental Health Research*.
- Lantagne, D.S. (2001a) *Investigation of the Potters for Peace Colloidal Silver Impregnated Ceramic Filter Report 1: Intrinsic Effectiveness*. Alethia Environmental: Allston, MA, USA.
- Lantagne, D.S. (2001b) *Investigation of the Potters for Peace Colloidal Silver Impregnated Ceramic Filter Report 2: Field Investigations*. Alethia Environmental: Allston, MA, USA.

- Larimer, C., Ostrowski, N., Speakman, J. and Nettleship, I. (2010) The segregation of silver nanoparticles in low-cost ceramic water filters. *Materials Characterization* 61: 408-412.
- LePape, H., Solano-Serena, F., Contini, P., Devillers, C., Maftah, A. and Leprat, P. (2002) Evaluation of the anti-microbial properties of an activated carbon fibre supporting silver using a dynamic method. *Carbon* 40: 2947-2954.
- LePape, H., Solano-Serena, F., Contini, P., Devillers, C., Maftah, A. and Leprat, P. (2004) Involvement of reactive oxygen species in the bactericidal activity of activated carbon fibre supporting silver: Bactericidal activity of ACF(Ag) mediated by ROS. *Journal of Inorganic Biochemistry* 98: 1054-1060.
- Li. Q., M.S., Lyon. D.Y., Brunet. L., Liga. M.v., Li. D., and Alvarez. P. J.J. (2008) Antimicrobial nanomaterials for water disinfection and microbial control: Potential applications and Implications. *Water Research* 42: 4591-4602.
- Liau, S.Y., Read, D.C., Pugh, W.J., Furr, J.R. and Russell, A.D. (1997) Interaction of silver nitrate with readily identifiable groups: relationship to the antibacterial action of silver ions. *Letters in Applied Microbiology* 25: 279-283.
- Lok, C.-N., Ho, C.-M., Chen, R., He, Q.-Y., Yu, W.-Y., Sun, H., Tam, P.K.-H., Chiu, J.-F. and Che, C.-M. (2007) Silver nanoparticles: partial oxidation and antibacterial activities. *Journal of Biological Inorganic Chemistry* 12: 527-534.
- Long, D., Wu, G. and Chen, S. (2007) Preparation of olichitosan stabilized silver nanoparticles by gamma irradiation. *Radiation Physics and Chemistry* 76: 1126-1131.
- Maneerung, T., Tokura, S. and Rujiravanit, R. (2007) Impregnation of silver nanoparticles into bacterial cellulose for antimicrobial wound dressing. *Carbohydrate Polymers* 72(1): 43-51.
- Merga, G., Wilson, R., Lynn, G., Milosavljevic, N.H. and Meisel, D. (2007) Redox catalysis on "naked" silver nanoparticles. *Journal of Physical Chemistry C* 111: 12220-12226.
- Miller, T.R. (2010) *Optimizing Performance of Ceramic Pot Filters in Northern Ghana and Modeling Flow through Paraboloid-Shaped Filters*. Unpublished Thesis, Massachusetts Institute of Technology
- Morones, J.R., Elechiguerra, J.L., Camacho, A., Holt, K., Kouri, J.B., Ramirez, J.T. and Yacaman, M.J. (2005) The bactericidal effect of silver nanoparticles. *Nanotechnology* 16: 2346-2353.
- Mossman, A. and Lam, S. (2004) *Ceramic Water Purifier Factory Equipment Manual*. Unpublished
- Navaroo, E., Peiccapietra, F., Wagner, B., Marconi, F., Kaegi, R., Odzak, N., Sigg, L. and Behra, R. (2008) Toxicity of silver nanoparticles to *Chlamydomonas reinhardtii*. *Environmental Science and Technology* 42(33): 8959-8964.
- Netherlands Water Partnership (2010) *Smart Disinfection Solutions*. KIT Publishers: Amsterdam.
- Olsen, F.L. (2001) *The Kiln Book materials, specifications & construction*. A & C Black: London.

- Orton (2001) [http://www.ortonceramic.com/resources/pdf/wall\\_chart\\_horiz.pdf](http://www.ortonceramic.com/resources/pdf/wall_chart_horiz.pdf). (Accessed November 2010).
- Oyanedel-Craver, V.A. and Smith, J.A. (2008) Sustainable colloidal-silver-impregnated ceramic filter for point-of-use water treatment. *Environmental science & technology* 42(3): 927-933.
- Pal, S., Tak, Y.K. and Song, J.M. (2007) Does the antibacterial activity of silver nanoparticles depend on the shape of the nanoparticle? A study of the gram-negative bacterium *Escherichia coli*. *Applied and Environmental Microbiology*: 1712-1720.
- Panacek, A., Kvittek, L., Pucek, R., Kolar, M., Vecerova, R., Pizurova, N., Sharma, V.K., Nevecna, T.j. and Zboril, R. (2006) Silver colloid nanoparticles: synthesis, characterization, and their antibacterial activity. *Journal of Physical Chemistry* 110: 16248-16253.
- Pelita (2009). Indonesia (Indo-2): Photograph provided by Pelita Indonesia in response to questionnaire.
- Peterson, B.E. (2009) *Kiln Types by Construction*. About.com:Pottery. <http://pottery.about.com/od/potterykilns/tp/typkilncons.htm>. (Accessed 2009).
- Petica, A., Gavrilu, S., Lungu, M., Buruntea, N. and Panzaru, C. (2008) Colloidal silver solutions with antimicrobial properties. *Materials Science and Engineering B* in press.
- PFP (2008) *PFP Home Page*. <http://www.pottersforpeace.org>. (Accessed 2008 Jan 20).
- Pillers, B. and Diaz, R.T. (2009) *Factory Overview; Addressing Recontamination*. International Ceramic Pot Filter Workshop, WEF Disinfection. Atlanta, GA, USA.
- Potters Without Borders (2010) Potters without Borders. [www.potterswithoutborders.com](http://www.potterswithoutborders.com). (Accessed September, 2010).
- POUZN (2007) *Best Practices in Social Marketing Safe Water Solution for Household Water Treatment: Lessons Learned from Population Services International Field Programs*. The Social Marketing Plus for Diarrheal Disease Control: Point-of-Use Water Disinfection and Zinc Treatment (POUZN) Project: Bethesda, MD.
- Rado, P. (1988) *An Introduction to the Technology of Pottery*. Pergamon Press, The Institute of Ceramics: Oxford.
- Raffi, M., Hussain, F., Bhatti, T.M., Akhter, J.I., Hameed, A. and Hasan, M.M. (2008) Antibacterial characterization of silver nanoparticles against *E. coli* ATCC-15224. *Journal of Material Science and Technology* 24(2): 192-196.
- Rayner, J. (2006) *Potters for Peace Ceramic Filter Production Manual*. Unpublished
- Rayner, J. (2009) *Current Practices in Manufacturing of Ceramic Pot Filters for Water Treatment*. Unpublished Thesis, Loughborough University
- RDI-C (2009) Personal Communication (with V. Craver).
- Rhodes, D. (1973) *Clay and Glazes for the Potter*. Krause Publications: Iola Wisconsin.
- Rivera-Garza, M., Olguin, M.T., Garcia-Sosa, I., Alcantara, D. and Rodriguez-Fuentes, G. (2000) Silver supported on natural Mexican zeolite as an antibacterial material. *Microporous and Mesoporous Materials* 39: 431-444.



- Roberts, M. (2004) *Field Test of a Silver-Impregnated Ceramic Water Filter*. People-Centred Approaches to Water and Environmental Sanitation. 30th WEDC International Conference, Vientiane, Lao PDR.
- Roberts, M.M.S. (2003) *Ceramic Water Purifier Cambodia Field Tests*, International Development Enterprises. IDE Working Paper No. 1.
- Ruparelia, J.P., Chatterjee, A.K., Duttagupta, S.P. and Mukherji, S. (2008) Strain specificity in antimicrobial activity of silver and copper nanoparticles *Acta Biomaterialia* 4: 707-716.
- Russell, A.D. and Russell, N.J. (1995) *Biocides: Activity, Action and Resistance*. Fifty Years of Antimicrobials: Past Perspectives and Future Trends. P. A. Hunter, G. K. Darby and N. J. Russell. Cambridge, Cambridge University Press.
- Sapsford, R. and Jupp, V. (1996) *Data collection and analysis*. Sage.
- Schmidt, M., Masson, A. and Brechignac, C. (2003) Oxygen and silver clusters: Transition from chemisorption to oxidation. *Physical Review Letters* 91(24): 3401-3405.
- Scholars, W.W.I.C.f. (2008) *The project on emerging nanotechnologies*.
- Shrivastava, S., Bera, T., Roy, A., Singh, G., Ramachandrarao, P. and Dash, D. (2007) Characterization of enhanced antibacterial effects of novel silver nanoparticles. *Nanotechnology* 18: 1-9.
- Silversty-Rodriguez, N.B., K.R., Slack, D.C., Uhlmann, D.R., and Gerba, C.P. (2008) Silver as a residual disinfectant to prevent biofilm formation in water distribution systems. *Applied and Environmental Microbiology* 74(5): 1639-1641.
- Sobsey, M., Stauber, C.E., Casanova, L.M., Brown, J. and Elliott, M.A. (2008) Point of use household drinking water filtration: A practical, effective solution for providing sustained access to safe drinking water in the developing world. *Environ Sci Technol* 42(12): 4261-7.
- Sondi, I. and Salopek-Sondi, B. (2004) Silver nanoparticles as antimicrobial agent: A study on *E. coli* as a model for gram-negative bacteria. *Journal of Colloid and Interface Science* 275: 177-182.
- Soukupova, J., Kvitek, L., Panacek, A., Nevecna, T. and Zboril, R. (2008) Comprehensive study on surfactant role on silver nanoparticles (NPs) prepared via modified Tollens process *Materials Chemistry and Physics* 111: 77-81.
- Thirst-Aid (2009): Photograph provided by Thirst-Aid in response to questionnaire.
- Thirst-Aid (2010): Photograph provided by Curt Bradner.
- Tien, D.-C., Tseng, K.-H., Liao, C.-Y. and Tsung, T.-T. (2008) Identification and quantification of ionic silver from colloidal silver prepared by electric spark discharge system and its antimicrobial potency study. *Journal of Alloy and Compounds* in press.
- Tun, W.W. (2009) *A Study of Arsenic Leaching from Colloidal Silver Ceramic Water Filters Manufactured in Myanmar*. UNICEF, Myanmar:
- UNICEF/WHO (2008) *Progress on drinking water and sanitation: special focus on sanitation*. UNICEF/WHO: Geneva, Switzerland.

- van Halem, D. (2006) *Ceramic silver impregnated pot filters for household drinking water treatment in developing countries*. Unpublished Thesis, Delft University of Technology, Delft.
- van Halem, D., van der Laan, H., Heijman, S.G.J., van Dijk, J.C. and Amy, G.L. (2009) Assessing the sustainability of the silver-impregnated ceramic pot filter for low-cost household drinking water treatment. *Physics and Chemistry of the Earth* 34(1-2): 36-42.
- Wagoner, K. (2010): Photograph provided by Kaira Wagoner.
- Web Resources Depot (2010) <http://www.webresourcesdepot.com/free-vector-world-maps-collection>. (Accessed 2010).
- WHO (1997) *Guidelines for drinking-water quality, 2nd Edition: Volume 3; Surveillance and control of community supplies*: Geneva, Switzerland.
- WHO (2004) *Guidelines for drinking-water quality, 3rd Edition; Volume 1: Recommendations*. World Health Organization: Geneva, Switzerland.
- WHO (2006) *Guidelines for drinking-water quality: first addendum to third edition*. World Health Organization: Geneva, Switzerland.
- Wright, J., Gundry, S. and Conroy, R. (2004) Household drinking water in developing countries: a systematic review of microbiological contamination between source and point-of-use. *Trop Med Int Health* 9(1): 106-17.

# Annex A. Scope of Work

## Scope of Work and Deliverables for Ceramic Manufacturing Working Group

### Goal:

Provide guidance to assist filter factories in producing the lowest-cost, most-effective ceramic filters possible.

### Objectives:

The objectives of this working group are to:

- summarize the existing knowledge on ceramic filter production and effects of production variables;
- identify lessons learned from existing filter factories;
- make recommendations on how to produce the lowest-cost, most-effective filters; and,
- identify research indicated.

### Deliverable:

The deliverable for this project will be a report from the panel of experts. The report will include the following chapters:

- Introduction (Daniele)
- Literature Review and Background on ceramic production and variables (Justine)
- Survey of production processes in existing ceramics filter factories (Justine)
- Chapters on the filter production processes, detailing:
  - Materials processing and source
  - Silver
  - Filter production
  - Firing
  - Delivery
  - Quality Control
- Conclusion (Daniele)
  - Lessons learned and what does/does not matter
  - Recommendations we can make now
  - Research indicated and identification of unknowns

The following cross-cutting themes that will be considered throughout the report include: cost, health and safety, environmental impact, breakage, microbiological efficacy, and end-user considerations.

In the report, the production variables associated with each topic will be discussed, and, depending on the groups discussion, the report will include the following outputs for each variable: 1) document what is known about the variable; 2) identify research needed; 3) make recommendations to filter producers;

4) establish a minimum standards; and/or, 5) describe best practices. It is understood that different variables may have different outputs.

**Timeline:**

The group will conduct a series of phone calls to develop the report. Each call will be lead by one member of the group, who will prepare information and an agenda for the call in advance and send to the entire group. After the call, the lead for that 'chapter' will draft a ~10-page chapter that will include a discussion of all the production variables identified relevant to the topic, and what is known about each variable, and recommendations from the working group. The chapters will be collected and collated by Daniele. The final report will be discussed in person in meetings in Ireland and Oklahoma City, as well as in a phone call in October. The goal is to release the report by first quarter 2010.

Call 1 (Scope, deliverables, lead – Daniele)	April 21 <sup>st</sup> , 2009
Call 2 (Materials, lead – Robert/Burt)	May 5 <sup>th</sup> , 2009
Call 3 (Silver, lead - Vinka)	May 27 <sup>th</sup> , 2009
Call 4 (Filter production – Lisa/Tracy)	June 10 <sup>th</sup> , 2009
Call 5 (Firing, lead ??)	June?
Call 6 (Delivery, lead ??)	July?
Call 7 (Quality control, lead ??)	July?
Call 8 (Survey results, lead Justine)	August?
Review and discuss draft report:	September 21-23 (Ireland) October 29 <sup>th</sup> (Oklahoma City)

The scope of work for the report will include only information relevant to production within the filter factory, and will not include field evaluation, behavior change, user training, or other 'outside the gates of the filter factory' information.

## Annex B. Conversion Tables

### B-1 Tyler Mesh Equivalent

US Sieve Size	Tyler Equivalent	Opening	
		mm	in
-	2½ Mesh	8.00	0.312
-	3 Mesh	6.73	0.265
No. 3½	3½ Mesh	5.66	0.233
No. 4	4 Mesh	4.76	0.187
No. 5	5 Mesh	4.00	0.157
No. 6	6 Mesh	3.36	0.132
No. 7	7 Mesh	2.83	0.111
No. 8	8 Mesh	2.38	0.0937
No. 10	9 Mesh	2.00	0.0787
No. 12	10 Mesh	1.68	0.0661
No. 14	12 Mesh	1.41	0.0555
No. 16	14 Mesh	1.19	0.0469
No. 18	16 Mesh	1.00	0.0394
No. 20	20 Mesh	0.841	0.0331
No. 25	24 Mesh	0.707	0.0278
No. 30	28 Mesh	0.595	0.0234
No. 35	32 Mesh	0.500	0.0197
No. 40	35 Mesh	0.420	0.0165
No. 45	42 Mesh	0.354	0.0139
No. 50	48 Mesh	0.297	0.0117
No. 60	60 Mesh	0.250	0.0098
No. 70	65 Mesh	0.210	0.0083
No. 80	80 Mesh	0.177	0.0070
No. 100	100 Mesh	0.149	0.0059
No. 120	115 Mesh	0.125	0.0049
No. 140	150 Mesh	0.105	0.0041
No. 170	170 Mesh	0.088	0.0035
No. 200	200 Mesh	0.074	0.0029
No. 230	250 Mesh	0.063	0.0025
No. 270	270 Mesh	0.053	0.0021

(AZoM 2009)

## B-2 Firing Chart

# Kiln Firing Chart

Firing converts ceramic work from weak greenware into a strong, durable permanent form. As the temperature in a kiln rises, many changes take place at different temperatures and understanding what happens during the firing can help you avoid problems with a variety of clay and glaze faults related to firing.

TEMPERATURE		CONE (approx.)	INCANDESCENCE	EVENT
°C	°F			
1400	2552	14	Brilliant white	End of porcelain range.
		13		
		12		
		11		
1300	2372	10	White	End of stoneware range.
		9		
		8	Yellow-white	
		7		
1200	2192	5	Yellow	End of earthenware (red clay) range.
		4		
		3		
		2		
1100	2012	03	Yellow-orange	1100–1200°C: Mullite and cristobalite (two types of silica) form as clay begins to convert to glass. Particles start melting together to form crystals, and materials shrink as they become more dense. Soaking (holding the end temperature) increases the amount of fused material and the amount of chemical action between the fluxes and the more refractory materials.
		04	Orange	
1000	1832	06	Red-orange	800–900°C: the beginning of sintering, the stage where clay particles begin to cement themselves together to create a hard material called bisque.
		07		
		08		
		09		
900	1652	011	Cherry red	300–800°C: Carbonaceous materials (impurities in the clay along with paper, wax, etc.) burn out. The kiln requires ample air during this stage since after 800°C sintering begins and the clay surface begins to seal off, trapping unburned materials and sulfides, which can cause bloating and black coring.
		012		
800	1472	013	Dull red	573°C: Quartz inversion occurs where the quartz crystals change from an alpha ( $\alpha$ ) structure to a beta ( $\beta$ ) structure. The inversion is reversed on cooling. This conversion creates stresses in the clay so temperature changes must be slow to avoid cracking the work.
		014		
		015		
		016		
700	1292	017	Dark red	Between 480–700°C chemical water ("water smoke") is driven off.
		018		
		019		
		020		
600	1112	021	Dull red glow	Upon cooling, cristobalite, a crystalline form of silica found in all clay bodies, shrinks suddenly at 220°C. Fast cooling at this temperature causes ware to crack.
		022		
500	932	022	Black	Water boils and converts to steam at 100°C. Trapped water causes clay to explode so keep the kiln below 100°C until all water has evaporated.
		022		
400	752			
300	572			
200	392			
100	212			

(CeramicArtsDaily 2010)

## Annex C. Survey Results Tables

### C-1 Mold and Filter Details

Country	Country of Manufacture	Material	Filter Height (cm)	Filter Diam. (cm)	Walls Thick (cm)	Capacity (liters)	Quantity in press (kg)
Benin	blank	Aluminum	24	32	0.1*	8	8
Cam-1	Cambodia	Cast-iron	24	33.5	1.7	10	9
Cam-2	Cambodia	Aluminum	blank	blank	blank	11	8
Colombia	blank	Aluminum	blank	blank	blank	blank	8
DR	Dominican Republic	Cement	28	28	1.6	6	5.4
Guate-1	Guatemala	Aluminum	23	32	blank	7	don't know
Guate-2	blank	Aluminum	28**	30.5**	2	11**	blank
Indo-1	Nicaragua	Aluminum	25	32	1.5	9	8.4
Indo-2	Indonesia	Aluminum	blank	blank	1.8	8	5.7
MM-All	Myanmar	Cast iron, Carved teak, Steel, or Aluminum	blank	blank	1.4	10	7
Nica-1	Managua	Aluminum	23.5	32	1	8	7.3
Nica-2	Nicaragua	Aluminum	22.5	31	blank	7	5
Nigeria	Nicaragua	Aluminum	blank	blank	blank	blank	blank
SL-1	Cambodia	Cast Iron	14*	blank	3	10	10.5
SL-2	Cambodia	Cast Iron	23	32	2.5	8	10
Tanz-1	Tanzania	Cement	29	33	2.1	8	8
Tanz-2	Nicaragua	Aluminum	blank	blank	0.5*	7	3*
Yemen	Nicaragua	Aluminum	blank	blank	blank	7	9
*this information does not appear to be accurate							
**calculated from responses provided in inches and US gallons.							

## C-2 Firing Practices

Country	Fuel	Pyro-meter	Cones	Visual	Number of Cones	Cone numbers	Target Temp °C	Frequency Achieved	Fire Time (hrs)
Cam-2	Wood	x	x		2	012,014	866	Always	10 - 12
MM-all	Wood	x	x	x	2	09,010	900	Almost Always	6 - 7
Nigeria	Wood	x	x		3	06	900	Almost Always	10 - 12
Tanz-1	Wood & Propane	x	x	x	3	012	880-900	Always	8
Cam-1	Wood		x		1	014	830	Always	12
Guate-1	Wood		x	x	varies	012	private	blank	private
Guate-2	Wood		x		2	014,012	847	Almost Always	11
Nica-1	Wood		x		3	010,012, 014	886	Always	8
Nica-2	Wood		x	x	1	012	830	Almost Always	8
Benin	Oil	x			n/a	n/a	900	Almost Always	12
Colombia	Wood	x			n/a	n/a	900	Usually	6
DR	Wood	x		x	n/a	n/a	980	Always	12
Indo-1	Wood	x			n/a	n/a	900	Always	8.5
Indo-2	Wood	x		x	n/a	n/a	832	Always	10 - 14
SL-1	Wood	x			n/a	n/a	800	Almost Always	15
SL-2	Wood	x			n/a	n/a	800	Almost Always	10 - 11
Tanz-2	Wood	x			n/a	n/a	700-920	Usually	6 - 8
Yemen	Propane	x			n/a	n/a	880	Always	11



### C-3 Production Logs

Information recorded by factories that always maintain production logs									
Country	Date made	Filter #	Lot #	Flow rate	Discard date	Discard reason	Date sold	Buyer Info.	Other
Cam-1	x	x	x	x					monthly account of number of filters sold
Guate-1	x	x	x	x			x	x	operator, conditions, materials/where from
Guate-2							x		
Indo-1	x	x	x	x	x	x	x	x	filter weight, drying time, kiln temp, visual faults
Indo-2	x	x	x	x	x	x	x	x	payments
MM-All	x	x	x	x			x	x	
Nica-1	x	x	x	x					dates cs applied, packaged, time, and date of firing
Nigeria	x	x	x	x	x			x	
SL-1	x	x		x	x			x	
SL-2	x	x	x	x	x	x*			formula for batch
Tanz-1			x	x		x			number of filters fired, microbiological test results
Tanz-2	x	x	x	x		x	x	x	
Yemen	x	x	x	x					
Benin	x								
Colombia		x	x	x					
DR	x	x		x*			x		microbiological test results

\*information is sometimes recorded

## C-4 Filter Testing

Country	Regular Testing	Quantity (%)	Factory	Lab	Turbidity	pH	TC	TTC	Fluoride	Silver	Arsenic	Comments
Guate-1	yes	blank	x	x	F/L	F/L	F/L	F/L	F/L	F/L	F/L	Based on quality control manuals.
Indo-1	yes	15%	x			F	F	F				
Indo-2	yes	2%		x		L	L	L	L	L	L	Two filters per week chosen randomly. Monthly: effluent water from 5-10 filters in the field is tested.
Benin	yes	blank		x	L	L	L		L	L	L	blank
DR	yes	8%		x		L	L					Effluent water is also tested from two filters in use every 2 months.
Cam-1	yes	0.2%	x	x			L			F		Microbiological tests carried out in lab. Field kit is used to confirm silver application.
MM-All	yes	1%		x			L					
Tanz-1	yes	4%	x	x			F/L					4% from each firing tested at factory, 4% from every other firing tested in lab.
Cam-2	yes	blank		x								Water quality index and primary chemical contaminants are tested for on a random sample monthly.
Guate-2	yes	blank		x								

Country	Regular Testing	Quantity (%)	Factory	Lab	Turbidity	pH	TC	TTC	Fluoride	Silver	Arsenic	Comments
Nigeria	yes	10%	x	x								Hach tests in factory. Two or three samples (in 9 months) tested in lab for <i>E. coli</i> and chemical analysis.
SL-2	yes	2%	x	x								Presence/Absence Hydrogen Sulfide kit in factory and some samples to lab.
Tanz-2	yes	blank		x								
Nica-1	no	blank		x			L	L				Also tests for streptococcus & <i>E. coli</i> .
SL-1	no	blank	x	x			F/L	F/L		F/L	F/L	
Yemen	no	blank	x				F					Hach tests from time to time. Clients conduct complete tests.
Colombia	no	blank										Others have tested the filters.
Nica-2	no	blank	x									

\* Key: F= in factory testing, L= laboratory testing

## Annex D. Raw Material Evaluations

The following sections describe simple tests for evaluating clay and burn-out material for quality and consistency. As raw materials are likely to change over time, carrying out these tests regularly and documenting the results is recommended. This will enable the comparison of characteristics to provide an indication of the consistency of the materials being used. When materials or material characteristics change, microbiological testing is needed to confirm the change has not adversely affected the quality of the filters produced.

### D-1 Clay Tests

The clay tests described below are recommended for determining the water of plasticity, shrinkage rates (dry, firing & total shrinkage), the firing temperature of a clay (using total shrinkage and percent porosity), and identifying the presence of lime (Rhodes 1973).

While a chemical analysis of a clay may aid in determining its composition, evaluating the physical nature of a clay and its reaction to firing are good ways of determining a clay's usefulness. Clays with different properties can be combined in order to achieve a clay body that has the desired characteristics.

#### D-1.1 Test for the Water of Plasticity

This test determines the amount of water required for a clay to become workable, of the desired consistency. Clay with a finer grain structure will require more water and will therefore shrink more during drying (Rhodes 1973). Carrying out this test periodically will identify changes in clay characteristics that might affect filter mixture ratio and the flow rate of the filter, because the amount of water required to achieve a plastic mixture is one determinant of the pore structure.

- 1) Thoroughly dry the clay sample, mill it, and sieve it through a 30 mesh screen.
- 2) Place 500 grams of clay (approximately one pound) onto a smooth, non-porous surface, such as glass.
- 3) Fill a 500 mL (cc) graduated cylinder with water and add the water to the clay a little at a time, mixing well after each addition.
- 4) Wedge the clay, adding more water from the cylinder, until the clay is a smooth mass of about the right consistency for modeling.
- 5) Note how much water was added to the clay.
- 6) Calculate the amount of water of plasticity using the following formula:

$$\text{Percent water of plasticity} = \frac{\text{Weight of water}}{\text{Weight of dry clay}} \times 100$$

#### D-1.2 Shrinkage

The amount of shrinkage is an important characteristic of any clay and will be partly determined by the amount of nonplastic material in the clay, the particle size, and the water content. A clay with a high shrinkage rate (more than 15% total shrinkage) probably will not be useful because it will warp and crack during drying and firing. Knowing the total shrinkage rate of the filter mixture will be useful for designing molds of the proper dimensions so that

after firing the filter element will fit precisely inside the available receptacle. Shrinkage tests should be carried out regularly on both the source clay and the filter mixture to monitor the consistency of raw materials.

### D-1.3 Dry Shrinkage

In this test, the dry linear shrinkage, or how much the clay shrinks during the drying process, is determined.

- 1) From a well-kneaded mass of clay using a specific water-to-clay ratio (for example, the amount of water used in the water of plasticity test above), make 9 bars that are 14 cm long, 4 cm wide, and about 1 cm thick.
- 2) On the face of each bar make a sharp scratch exactly 10 cm long.
- 3) Allow the bars to dry slowly and evenly; turn them as needed to prevent warping.
- 4) Once dry, re-measure the length of the scratch.
- 5) Determine dry shrinkage using the following equation:

$$\text{Percent linear shrinkage} = \frac{\text{Plastic length} - \text{dry length}}{\text{Plastic length}} \times 100$$

### D-1.4 Firing Shrinkage

Firing shrinkage is usually determined on samples that have been fired to several different temperatures (for instance, 800°C, 850°C, and 900°C), following the standard firing schedule. This gives an idea of the progressive shrinking of the clay as the temperature is increased.

- 1) Mark each bar made for the previous test with a test firing temperature.
- 2) Fire the dried bars: three bars should be fired to each test temperature.
- 3) Measure the length of the scratch on the fired bar.
- 4) Calculate the firing shrinkage using the following equation:

$$\text{Firing shrinkage} = \frac{\text{Dry length} - \text{Fired length}}{\text{Dry length}} \times 100$$

### D-1.5 Total Shrinkage

Total shrinkage is how much the clay or filter mixture shrinks from its plastic state to its fired state and can be calculated using the following equation:

$$\text{Total shrinkage} = \frac{\text{Plastic length} - \text{fired length}}{\text{Plastic length}} \times 100$$

### D-1.6 Percent Absorption (Porosity)

The firing temperature of a clay can be assessed by evaluating total shrinkage (see above) and absorption test results. During the ceramic change (approximately 600°C), the chemically-bound water fires out leaving leaves spaces where the water was, thus making the ceramic porous. As firing continues, the clay shrinks and these spaces fill up (vitrification). As a clay body vitrifies, it becomes less porous. Therefore, the degree of water

absorption of the fired clay, or percentage porosity, is also a measure of the maturity of a fired clay body. Earthenware clay, by definition, will have a greater than 5% porosity when fired to maturity. Porosity of filters has been measured to range from 30-44% (van Halem 2006; Oyanedel-Craver and Smith 2008).

- 1) Use the test bars fired to different temperatures from the firing shrinkage test above.
- 2) While still warm from the kiln, carefully weigh the fired pieces to the nearest centigram.
- 3) Boil the fired pieces in water for 5 minutes.
- 4) Dry the surface of the bars with a damp sponge and weigh each one again.
- 5) Calculate the absorption, using the following equation:

$$\text{Percent absorption} = \frac{\text{Saturated weight} - \text{dry weight}}{\text{Dry weight}} \times 100$$

### **D-1.7 Test for the Presence of Lime**

Although lime has not been observed to cause a problem in filters, if a clay contains whitish lumps or the area from which the clay was mined is known to contain limestone, finished filters should be checked for “lime popping” and clay should be tested for calcium. After firing, lime will slowly absorb moisture from the air and expand (calcium hydroxide), causing a section of the body to pop off, leaving a half-moon shaped crack in the fired clay.

To detect the presence of calcium in a clay source, a sample of the clay is put into a glass container containing a 50% solution of hydrochloric acid (HCl). If lime is present, the clay will release gasses in the form of bubbles (Rhodes 1973: 65). Screening clay with a 40 mesh should be sufficient to remove lime large enough to cause a problem in filters. If this does not work, another clay source might need to be found.

## **D-2 Burn-out Material Tests**

### **D-2.1 Measuring Moisture Content**

Burn-out material should be dehydrated before it is weighed since the ambient humidity can affect the weight of burn-out material enough to affect the accuracy of the filter mixture ratio. Variation in moisture content of the burn-out can be measured to provide an idea of how much it is affected by the ambient humidity during different seasons. Heat a measured amount (by weight) of burn-out material to approximately 100°C, hold the temperature for a few hours, and then compare the weight of the heated, fully dried mass to the weight of the initial mass.

### **D-2.2 Test for Purity of Burn-out**

Place one spoonful (approximately 5 grams), of burn-out material in a ceramic dish and fire it under a standard firing profile. Material remaining in the dish after the firing is complete can be evaluated for contamination to determine whether a different source of burn-out material should be found.

## Annex E. Clay Blending Methods

When preparing a clay body with two or more ingredients, methods of line and triaxial blending are essential in determining the materials ratio. Line blending is useful when two materials are used, such as a local clay and a burn-out material. Triaxial blending is useful in cases where a single clay may not be suitable, but a combination of two local clays may work. For example, in a case where a blend of two local clays and one burn-out material (or alternatively, one local clay and a combination of two types of burn-out material) will be used. Filter mixture typically contains 40 – 60% clay. In most cases, experimentation will start with an initial body composition of 50% clay and 50% (by volume) burn-out material, with testing proceeding within the relatively narrow range of 60% of one material to 40% of the other. Explanations of blending methods follow.

### E-1 Line Blending

The simplest type of methodical blend is the line blend. This kind of blend establishes a series of variations or mixes between two materials. Since we know that the acceptable range of materials in a filter mixture varies from 40% to 60% by volume of clay to burn-out material, we can begin the initial testing process by preparing the following ratios:

Clay	40%	45%	50%	55%	60%
Burn-out	60%	55%	50%	45%	40%

If, for example, in the initial round of testing, the most successful candidates were the mixtures containing 50% and 55% clay, a second series of tests could be performed within this range as follows:

Clay	50%	51%	52%	53%	54%	55%
Burn-out	50%	49%	48%	47%	46%	45%

In this manner, the most effective ratio of the two ingredients can be efficiently arrived at with a minimum of testing.

Another type of line blend may be illustrated as follows:

1	2	3	4	5	6
	1-2	1-3	1-4	1-5	1-6
		2-3	2-4	2-5	2-6
			3-4	3-5	3-6
				4-5	4-6
					5-6

The top numbers, 1 to 6, may be any set of variables. In the next row down, 1-2 is a half-and-half mixture of number 1 and number 2; 1-3 is a half-and-half mixture of 1 and 3; and, so on. This type of blend exhausts all the mathematically possible 50-50 combinations of the variables in the top row.

## E-2 Tri-axial blending

When three materials are to be blended, such as when clay from two sources needs to be blended with a burn-out material, the triaxial blending method is used to test various combinations of the three materials.

In the diagram below, A and B could represent clays from two different sources, and C could be the burn-out material. Since the points on the outside lines of the triangle only contain two of the three materials, they are, in effect, the same as straight line blends. The points between A and B represent a line blend of the two clays; the points between B and C represent a blend of Clay B with Burn-out C; and the points between A and C represent a blend of Clay A with Burn-out C. The midway point in each line represents half of one ingredient and half of the other. Since the triangle is divided into ten parts, each point at the intersection of the lines represents a 10% change in the amount of each material. So, each point on the outside lines of the triangle will have more or less of the end ingredients, depending on its distance from that ingredient's corner. Point Y, for example, represents a mixture of 60% of Clay A and 40% of Burn-out C. This would be within the normal range for filter mixture testing.

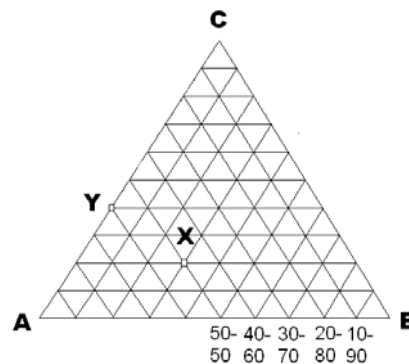
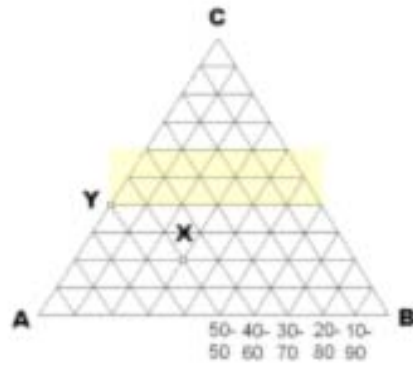

Figure E-2-1 Triaxial Blending Triangle  
(Rhodes 1973)

The points inside the triangle represent various mixture ratios of all three ingredients. The composition of a point on the inside similarly depends on its distance away from the points at the corner. Point X, for example, will contain 50% of Clay A, since it is five spaces removed from A. It will contain 30% of Clay B, since it is seven spaces removed from B, and 20% of Burn-out C, since it is eight spaces removed from C, which would be outside the normal range for filter mixture testing since the burn-out material is less than 40%. The composition of any other point in the diagram can likewise be determined by counting the number of spaces it is from each corner. The total of the three ingredients must always add up to 100%.

In filter mixture testing, we do not need to use the entire triangle. Since we normally test burn-out ratios between the ranges of 40%-60%, we can simplify our testing by eliminating the portions of the triangle outside of those ranges, to create a new diagram that only includes the ranges to be tested. To begin, we highlight the portion of the diagram that represents Burn-out C within the ranges of 40%-60%:





The horizontal line at Point Y represents 40% of Burn-out C, the line above it 50% of Burn-out C, and the top highlighted line 60% of Burn-out C. Next, the section of the triangle within the desired range for Clay A is highlighted:

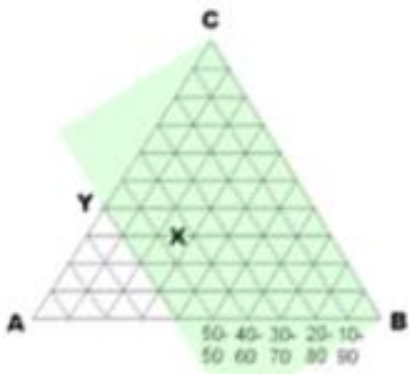

And then do the same for Clay B:

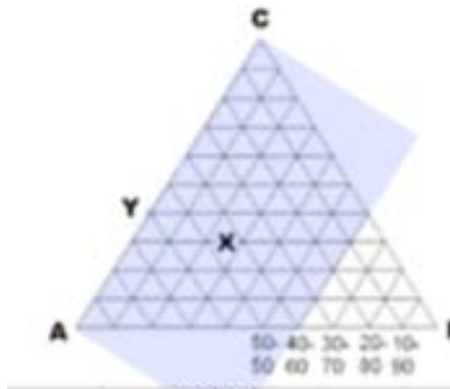

By selecting the area where the colors overlap, the proportions of each material to be tested are determined:

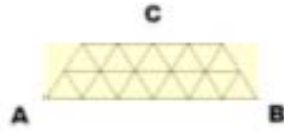

We have now reduced the number of tests necessary from 66 to 18. The proportions of each of the three ingredients at each point on the diagram are calculated as follows:

<b>A 40</b>	<b>A 30</b>	<b>A 20</b>	<b>A 10</b>	<b>A 0</b>
<b>B 0</b>	<b>B 10</b>	<b>B 20</b>	<b>B 30</b>	<b>B 40</b>
<b>C 60</b>	<b>C 60</b>	<b>C 60</b>	<b>C 60</b>	<b>C 60</b>

<b>A 50</b>	<b>A 40</b>	<b>A 30</b>	<b>A 20</b>	<b>A 10</b>	<b>A 0</b>
<b>B 0</b>	<b>B 10</b>	<b>B 20</b>	<b>B 30</b>	<b>B 40</b>	<b>B 50</b>
<b>C 50</b>	<b>C 50</b>	<b>C 50</b>	<b>C 50</b>	<b>C 50</b>	<b>C 50</b>

<b>A 60</b>	<b>A 50</b>	<b>A 40</b>	<b>A 30</b>	<b>A 20</b>	<b>A 10</b>	<b>A 0</b>
<b>B 0</b>	<b>B 10</b>	<b>B 20</b>	<b>B 30</b>	<b>B 40</b>	<b>B 50</b>	<b>B 60</b>
<b>C 40</b>	<b>C 40</b>	<b>C 40</b>	<b>C 40</b>	<b>C 40</b>	<b>C 40</b>	<b>C 40</b>

These 18 options can be used for initial testing. If one of them is not the obvious best choice, the three options that give the best results can be chosen for new corners of the triangle, and by testing the ratios between the corners in a way similar to the explanation given in the line blend section, we can target the precise ratio of materials to be used in production.

## Annex F. Additional Tests

### F-1 Filter Cross Section

When a new mold is installed in a press it must be checked to ensure that the male and female molds are centered and not tilted. The mold alignment is checked by cutting a freshly pressed filter in half and then quarters lengthwise with a wire and then measuring the thickness of the wall and the base of the filter in several places with calipers (Figure 5-8). Even though this is a destructive test, some fired filters meeting other quality control guidelines should be cut in half and the cross section evaluated to check the mold alignment and for complete firing. A handsaw or another appropriate tool can be used to cut fired filters lengthwise into at least 2 pieces. The cross section of 20% of fired prototype filters should be evaluated. Once a factory starts regular production, 0.4% of fired filters produced should be checked (Table 11). If high discard rates are noted, cross sections of rejected filters should be evaluated to identify potential causes.

#### F-1.2 Check Mold Alignment:

The alignment of the mold can be checked by evaluating the cross section of freshly pressed and fired filters (see Figure 5-8):

- 1) Once the filter has been cut, measure the wall thickness to the nearest millimeter with calipers and record the thickness of the filter wall.
- 2) Measure and record the thickness of the opposing filter wall at the same height on the filter.
- 3) Do this at several heights of the filter walls.
- 4) Measure and record the thickness of the base of the filter in various locations.
- 5) Compare the thicknesses; if either the wall thickness or the base thickness varies more than 10%, the molds need to be checked and corrected for alignment.

#### F-1.3 Check Complete Firing:

The cross section of fired filters should be examined to check for complete combustion of burn-out material:

- 1) Visually inspect the cross section of the filter walls for consistent color throughout; a small amount of color variation is acceptable.
- 2) Look for evidence of incomplete burn out of burn-out material or a dark core.
- 3) Record observations and compare with the firing-log from the specific firing.

Until further research has been carried out, leaving a black core in the filter walls is not recommended. If there is evidence of a black core in fired filters, the amount of time and the amount of oxygen in the kiln should be increased when firing between 700°-900°C (Section 6.8.6), draw trials should be used (Section 6.5.4), and an increased number of filters from future firings should be checked to confirm the black core has been successfully oxidized.

## **F-2 Kiln Temperature Mapping**

Kiln temperature mapping should be carried out on new kilns (two runs), annually, and when there is concern the kiln is not firing evenly. By evaluating the deformation of cones placed in different parts of the kiln during a firing the sections of the kiln that are subjected to more or less heatwork can be identified.

- 1) Prepare seven cone packs of three cones each (for example, cone 012 as a guide cone, 011 as the firing cone, and 010 as the guard cone).
- 2) Place each cone pack in a different location in the kiln including: one cone pack in each of the four corners (one at each end of the bag wall), one by each of the spy holes, and one in the middle of the kiln about halfway up.
- 3) Stack the kiln with filters so the firing will be representative of a normal firing and fire the kiln according to a standard firing profile.
- 4) After the kiln has cooled, label each cone pack as it is removed from the kiln and mark the location where it was in the kiln on a drawing of the interior of the kiln.
- 5) Note the difference in cone deformation to learn where the cool spots versus hot spots are in the kiln.
- 6) Any adjustments that need to be made to the kiln to even out the temperature distribution should be made before the next firing.

Adjustments to the kiln could include lowering, raising, or adding openings in the floor near the bag wall. Bricks should only be separated near the flame port; if the bricks close to the flue exit are separated, heat will be sucked in from the firebox. During the firing, the damper can be adjusted to influence heat distribution. See Chapter 6 for more tips on controlling heat distribution during firing.

## **F-3 Tap Leak Test**

Taps typically leak at the screw tap or at the inlet seal. One person should be able to test approximately 250-300 taps in 4-5 hours. RDI-C tests their taps using the following method:

- 1) Attach compressed air to an open end of the tap.
- 2) Apply approximately 1 kg/cm<sup>2</sup> (100 kPa) of air pressure.
- 3) Submerge the tap in water.
- 4) Bubbles rising from the tap indicate a leak.

# Annex G. Sample Production Logs

## G-1 Clay Evaluation Log

Clay Evaluation Log			
Factory:	<input type="text"/>	Date:	<input type="text"/>
Employee:	<input type="text"/>	Code:	<input type="text" value="C-"/>
Clay Source:	<input type="text"/>		
Location:	<input type="text"/>	Level in mine:	<input type="text"/>
Reason for carrying out tests: <input type="text"/>			
Description of Raw Clay:	Color:	<input type="text"/>	
	Texture:	<input type="text"/>	
	Other:	<input type="text"/>	
Observations : <input type="text"/>			
Processing:	Sieve mesh #:	<input type="text"/>	
	Amount discarded:	<input type="text"/> kg	per: <input type="text"/> kg
Water of Plasticity	<input type="text"/>	%	
	Starting Mass:	<input type="text"/>	gr
	Water Added:	<input type="text"/>	ml
Dry Shrinkage	<input type="text"/>	%	
	Plastic length	<input type="text"/>	cm
	Dry length	<input type="text"/>	cm
Temperature fired: <input type="text"/> °C <input type="text"/> °C <input type="text"/> °C			
Fired Shrinkage	Fired length	<input type="text"/> cm	<input type="text"/> cm
	Fired shrinkage	<input type="text"/> %	<input type="text"/> %
Total Shrinkage	<input type="text"/>	%	
	<input type="text"/>	%	
	<input type="text"/>	%	
Water Absorption	Fired weight	<input type="text"/> gr	<input type="text"/> gr
	Saturated weight	<input type="text"/> gr	<input type="text"/> gr
	Percent absorption	<input type="text"/> %	<input type="text"/> %

## G-2 Burn-out Evaluation Log

Burn-out Evaluation Log			
Factory:	<input style="width: 95%;" type="text"/>	Date:	<input style="width: 95%;" type="text"/>
Employee:	<input style="width: 95%;" type="text"/>	Code:	<input style="width: 95%;" type="text" value="B-"/>
Supplier:	<input style="width: 95%;" type="text"/>		
Date Received:	<input style="width: 95%;" type="text"/>		
Type:	<input style="width: 95%;" type="text"/>		
Reason for evaluation:		<input style="width: 95%;" type="text"/>	
Description:	Part of husk:	<input style="width: 95%;" type="text"/>	
	Color:	<input style="width: 95%;" type="text"/>	
	Texture:	<input style="width: 95%;" type="text"/>	
	Other:	<input style="width: 95%;" type="text"/>	
Processing by supplier:		<input style="width: 95%;" type="text"/>	
Particle size received:		<input style="width: 95%;" type="text"/>	
In-house processing:			
	Mill/grinder:	Type:	<input style="width: 95%;" type="text"/>
	Sieve	Mesh #1	Estimated particle size for production: <input style="width: 95%;" type="text"/>
		Mesh #2	
Quantity discarded	<input style="width: 95%;" type="text"/>	kg	per <input style="width: 95%;" type="text"/>
Moisture content:	<input style="width: 95%;" type="text"/>	%	
Contaminants test result:		<input style="width: 95%;" type="text"/>	
Observations:		<input style="width: 95%;" type="text"/>	

### G-3 Filter Mixture Log

Filter Mixture Log			
Factory:		Date:	
Employee:		Code:	M-
Clay Code:			
Burn-out Code:			
Estimated number of Filters:			
Ratio (this batch):		Established Ratio:	
Clay:		Clay:	kg
Burn-out:		Burn-out:	kg
Water:	kg/liters	Water:	kg/liters
Additional Materials:			
Description:			
Quantity:	kg		
Reason for variation in ratio:			
Dry mix machine/method:			
Dry mix time:		min	
Wet mix machine/method:			
Wet mix time:		min	
Additional Processing:			
Kneading/Wedging:			
Pug mill:			
<b>Mixture Evaluation:</b>			
Plastic length		cm	
Dry length		cm	
Dry Shrinkage		%	
Temperature fired:		°C	
Fired Shrinkage:	Fired length	cm	
	Fired shrinkage	%	
Total Shrinkage:			
	%		
Water Absorption:	Fired weight	gr	
	Saturated weight	gr	
	Percent absorption	%	

# G-4 Filter Weight and Filtration Rate Log

<b>FILTER FACTORY NAME</b>										<b>DP 1</b>	
<i>Daily Production YEAR</i>											
<b>#of Filters</b>			Pressed		DATE						
<b>BATCH XX</b>										<input type="text"/> Fire Date	
Code: S/N per factory			12 ltr water		MIX ratioXX						
No: filter	Weight check				Filtration after firing	No: filter	Weight check				Filtration after firing
	Press	Before firing	Out kiln	Wet			Press	Before firing	Out kiln	Wet	
1						26					
2						27					
3						28					
4						29					
5						30					
6						31					
7						32					
8						33					
9						34					
10						35					
11						36					
12						37					
13						38					
14						39					
15						40					
16						41					
17						42					
18						43					
19						44					
20						45					
21						46					
22						47					
23						48					
24						49					
25						50					
<b>#of Filters low filtration after firing</b>											



# G-5 Production Control Log

		LOT #		KILN:			FIRING TIME:			
FILTER #	DATE	DRY	DATE	FILTRATION RATE			DATE	DATE	DATE	OBSERVATION
	PRESS		FIRE	<1 LR/H	1-2.5 LR/H	>2.5 LR/H	REFIRE	SILVER	PACK	
1										
2										
3										
4										
5										
6										
7										
8										
9										
10										
11										
12										
13										
14										
15										
16										
17										
18										
19										
20										
21										
22										
23										
24										
25										
26										
27										
28										
29										
30										
31										
32										
33										
34										
35										
36										
37										
38										
39										
40										
41										
42										
43										
44										
45										
46										
47										
48										
49										
50										
TOTAL										

# G-6 Production Control Log

## Filter Production workshop

### Production Control

Item	Pressed Code	Fired		Filtration rate		Comments and final destination, NGO and user	Item	Pressed Code	Fired		Filtration rate		Comments and destination
		Date	Damaged in firing	Lt/hr	Not Accepted				Date	Damaged in firing	Lt/hr	Not accepted	
1		/ /					31		/ /				
2		/ /					32		/ /				
3		/ /					33		/ /				
4		/ /					34		/ /				
5		/ /					35		/ /				
6		/ /					36		/ /				
7		/ /					37		/ /				
8		/ /					38		/ /				
9		/ /					39		/ /				
10		/ /					40		/ /				
11		/ /					41		/ /				
12		/ /					42		/ /				
13		/ /					43		/ /				
14		/ /					44		/ /				
15		/ /					45		/ /				
16		/ /					46		/ /				
17		/ /					47		/ /				
18		/ /					48		/ /				
19		/ /					49		/ /				
20		/ /					50		/ /				
21		/ /					51		/ /				
22		/ /					52		/ /				
23		/ /					53		/ /				
24		/ /					54		/ /				
25		/ /					55		/ /				
26		/ /					56		/ /				
27		/ /					57		/ /				
28		/ /					58		/ /				
29		/ /					59		/ /				
30		/ /					60		/ /				
<b>Total</b>							<b>Total</b>						

# G-7 Firing Log

Process Control Report No.:			Factory:			Activity:		Date:	
Item	Broken		Rejected		Filtration			Observations	
	Trim	Dry	Fire	Dim.	Other	Lt/hr			
						Low	Pass		
1									Pressed
2									Trimmed
3									Fired
4									Flow rate test
5									<b>Firing Log</b>
6									Time
7									Firing Time
8									T1
9									T2
10									T3
11									T4
12									00:00
13									00:15
14									00:30
15									00:45
16									01:00
17									01:15
18									01:30
19									01:45
20									02:00
21									02:15
22									02:30
23									02:45
24									03:00
25									03:15
26									03:30
27									03:45
28									04:00
29									04:15
30									04:30
31									04:45
32									05:00
33									05:15
34									05:30
35									05:45
36									06:00
37									06:15
38									06:30
39									06:45
40									07:00
41									07:15
42									07:30
43									07:45
44									08:00
45									08:15
46									08:30
47									08:45
48									09:00
49									<b>Peak Temperature Reach</b>
50									Cone Fall Times (Do not let the control cone fall!)
51									014
52									012
53									010
									08
									06
									Temp
									Time
									<b>Materials Used</b>
									Clay
									Burnable
									Water
									Mould release
									Fuel
									<b>Number of Rejected Filters:</b>

# G-8 Filter Placement Log in Kiln

FILTER FACTORY NAME										PF2			
Filter postion in Kiln										##	filters		
EXAMPLE SHEET										BATCH	##		
row 1											Kiln No:	#	
layer5											Controle	NAME	
layer4					38								
layer3				9		13							
layer2			5		8		41						
layer1	14	10		32		33		4					
										Inlet			
row 2													
layer5						56		58					
layer4					46		47		53				
layer3				19		61		43		68			
layer2			3		34		66		37		36		
layer1	19		11		30		14		15		65		
row 3													
layer5							55						
layer4						50		49					
layer3					70		72		1				
layer2				51		57		60		71			
layer1	14			25		21		22		54			
										outlet			
row 4													
layer5						52							
layer4					27		31						
layer3				29		26		73					
layer2			2		45		67		42				
layer1	14		20		75		44		40				
row 5													
layer5						69							
layer4				28		38							
layer3			48		17		74						
layer2		24		59		16		12					
layer1	14	23		18		62		64					
										Inlet			
	75												

## Annex H. Silver Dilution

The following sections provide guidelines for diluting powdered and liquid colloidal silver for application to fired ceramic filters by brushing. Concentrated silver may be prepared on a weekly basis and diluted for application to filters on a per filter (recommended) or daily basis. Silver should be diluted with non-chlorinated boiled, filtered, bottled, or deionized water, preferably with a low calcium concentration to prevent the aggregation of silver particles. The equations provided can be used to calculate the amount of colloidal silver (in mg) actually applied to each fired filter. The standard amount of colloidal silver applied to each filter is 64 mg achieved by brushing 302 mL of 211 ppm (211 mg of silver per liter of water, 0.021%) solution.

The first section provides guidelines for preparing a 3.2% concentrated solution from powdered colloidal silver. The second section provides instructions for diluting the 3.2% concentrated solution to the 0.021% strength required for application to each filter and instructions for preparing a batch of application strength solution for same day application. Additional instructions are provided for preparing the appropriate dilution if liquid silver of a concentration other than 3.2% is purchased. Although silver nitrate is not recommended until further research has been carried out, instructions for silver nitrate dilution are provided.

Recommended health and safety precautions and methods to reduce environmental contamination by silver, including disposal recommendations, should be followed according to local regulations in addition to those outlined in Section 7.6.

The following conversions might be helpful in understanding the quantities discussed:

Conversions: 0.001 gram/L = 1 mg/L = 1 ppm = 0.0001%;

Concentrated solution: 32 gram/L = 32,000 mg/L = 32,000 ppm = 3.2%; and,

Application solution: 0.211 gram/L = 211 mg/L = 211 ppm = 0.021%.

### H-1 Preparing a 3.2% concentrated solution from powdered silver

Dry silver powder is rarely 100% silver. Collargol, from Laboratorios Argenol in Spain, ranges from 70-75% silver. To calculate the dilution factor needed to create a 3.2% liquid concentrated solution, first find out from the label, or directly from the manufacturer, the silver content of the powder to be used. The goal is to add 16 grams of silver to 500 mL of water.

Calculate the quantity of powder to add using the following formula:

$$\frac{16}{\text{Silver concentration (decimal)}} = \text{Amount of powder to add (grams)}$$

EXAMPLE: If the powder contains 70% silver, 23 grams of 70% (0.70 in decimal) silver powder should be added to 500 mL of water, found by dividing 16 by 0.70:

$$\frac{16}{0.70} = 23 \text{ (grams)}$$



specified. Measure out 302 mL of this solution in a separate container and applied to each filter to ensure each filter receives 302 mL of solution according to the application guidelines in Section 7.6.

EXAMPLE: For a batch of 50 filters, add 100 mL of 3.2% concentrate solution to 15 L of dilution water:

$$\begin{aligned} (50 \text{ filters} \times 2\text{mL}) &= 100 \text{ mL of concentrate} \\ &+ \\ (50 \text{ filters} \times 0.30) &= 15 \text{ L of water} \end{aligned}$$

### H-3 Preparing the application solution (0.021%) from a colloidal silver solution other than 3.2%

If the starting colloidal silver solution has a concentration greater than 3.2%, first dilute the solution to 3.2%, then prepare the application solution for each filter. Use the following equation to calculate the quantity of water required to dilute 100 mL of colloidal silver solution:

$$\left[ \frac{\% \text{ strength colloidal silver solution}}{3.2} \right] - 1 = \text{water (mL)}$$

Add the amount of water calculated above to 100mL of the colloidal silver solution to dilute it to the concentrated strength of 3.2%.

EXAMPLE: If the colloidal silver solution contains 5% silver, add 155 mL of dilution water to 100 mL of the 5% solution to obtain 255 mL of 3.2% solution:

$$\left[ \frac{5}{3.2} \right] - 1 = 1.55\text{mL water} + 100\text{mL (of the 5\% solution)} = 255 \text{ mL (3.2\% solution)}$$

If the starting colloidal silver solution contains less than 3.2% silver (but more than 0.021%, or 211 ppm), then create the application solution directly, using the same calculations suggested above for the batch preparation, but scaled. After determining the number of filters to be coated in the batch, use the following equation:

$$\begin{aligned} (\text{number of filters}) \times 0.30 &= \text{water (L)} \\ &+ \\ (\text{number of filters} \times 2) \times \left[ \frac{3.2}{\% \text{ silver concentration}} \right] &= \text{concentrate solution (mL)} \end{aligned}$$

EXAMPLE: To prepare an application strength solution from a 1% silver solution, 320 mL of the 1% colloidal silver solution would be added to 15 L of water; this will be enough to coat 50 filters, each with 302 mL of the newly created application solution:

$$\begin{aligned} 50 \times 0.30 &= 15 \text{ (L)} \\ &+ \\ (50 \times 2) \times \left[ \frac{3.2}{1} \right] &= 320 \text{ (mL)} \end{aligned}$$

## H-4 Silver Nitrate Dilution

At present, we do not recommend using silver nitrate on ceramic water filters until further research has been carried out as it may disassociate from the filter at a faster rate than colloidal silver. This causes concerns with: 1) the amount of time silver nitrate would last in the filter; and, 2) whether the amount of silver that initially leaches into filtered water exceeds WHO guidelines. Effort must be made to obtain colloidal silver for application to ceramic water filters. Although we do not recommend the use of silver nitrate, dilution instructions follow.

The following instructions were copied from the RDI-C manual (Hagan *et al.* 2009) for diluting silver nitrate:

- 1) Add 100g AgNO<sub>3</sub> crystals (99.8% purity) to 500 ml of deionized water, mix well.
- 2) Add another 1000 ml of deionized water and mix for 1 minute.
- 3) Store the silver solution concentrate in a light proof plastic container.
- 4) To dilute silver concentrate for use, dilute 100 ml of the silver concentrate with 18 liters of distilled water and mix.

This makes enough for approximately 60 filter elements. Keep containers closed to prevent oxidization. Approximately 47 mg of silver nitrate (200 ml) is applied to the inside and approximately 23 mg (100 ml) is applied to the outside of the filter by brushing.



# Annex I. Equipment Information

Whenever possible equipment should be purchased or manufactured locally both to support the local economy but also for easier access to local repair.

## I-1 How to make a T-Piece

A calibrated T-piece can be used to measure the drop in water level for flow rate testing. Factories which choose to use this method should make their own to ensure it measures the drop in water level accurately in the filters they produce. Instructions for making a T-piece have been adapted from the RDI-C Ceramic Water Filter Handbook (Hagan *et al.* 2009).

- 1) Take two pieces of plastic pipe about 45 cm long and cut one piece of pipe to a length that is 2 cm longer than the rim width of the ceramic filter (this will be the horizontal pipe).
- 2) Cut out a horizontal section (about 5 cm long) from half the width of the pipe at both ends so the pipe sits flat on the rim of the filter element.
- 3) Drill a hole about 3 cm from the end of the remaining pipe (the vertical pipe). The size of the hole should allow the horizontal pipe to be inserted with a tight fit.
- 4) Insert the horizontal pipe through the hole in the vertical pipe until it forms a T shape.
- 5) Drill a small hole in the bottom of a fired filter.
- 6) Saturate the filter.
- 7) Set up the filter with the t-piece inside and a measuring container below to collect the water. The horizontal pipe should rest evenly on the filter rim and the vertical pipe should be inside the filter element.
- 8) Fill the filter with water.
- 9) When 0.5 L is collected in the measuring container, block the hole and make a notch on the vertical pipe to indicate the water level after that volume of flow.
- 10) Repeat the previous step after the collection of 1L, 1.5L, 2L, 2.5L, 3L, etc.
- 11) Double-check the measurements by setting up the t-piece in another saturated filter that does not have a hole in the bottom. Add a measured amount of water to the filter to reach the lowest level marked on the t-piece.
- 12) Add water in half liter increments and check that the water level matches the marking for each addition of water.
- 13) Drill a small hole in the t-piece at each notch and label the drop in water volume at each point with waterproof paint.

Note: The hole drilled during step 6 must be small enough to have a steady but slow discharge rate. After the t-piece is made, the filter with a hole in the bottom should be destroyed. Water levels other than those suggested above can be marked on the t-piece if required. Variation in filter shape and volume will affect the accuracy of the t-piece.

## I-2 Mixer

Manny Hernandez manufactured a mixer for a Haiti project by modifying a car differential which was used as the transmission. This was cheaper than buying a reduction motor or a transmission. The formula he used was:

$$\frac{\text{Velocity of motor}}{\text{Diameter of pulley on motor (3" dia)}} = \frac{\text{Diameter of Pulley (mounted on Drive Shaft - 16" dia)}}{\text{Velocity of shaft (modified wheel shaft) 5 to 1 ratio}}$$

A 7.5 HP motor with a 3" pulley was used. The modified differential on the drive shaft side had a 15" pulley which was turned by the motor. A 3" diameter sprocket was mounted on the wheel shaft side of the differential. The sprocket on the mixer shaft was 16" diameter. The sprockets and the chain were heavy duty at #80.



Mixer in Haiti  
(Hernandez 2010)

## I-3 Press

Plans for the construction of a press using a hydraulic truck jack can be reviewed and downloaded from <http://www.pottersforpeace.org/>.

## I-4 Molds

### I-4.1 Flat Bottomed Mold

The following drawing is for the PFP flat bottomed mold (February, 2006).

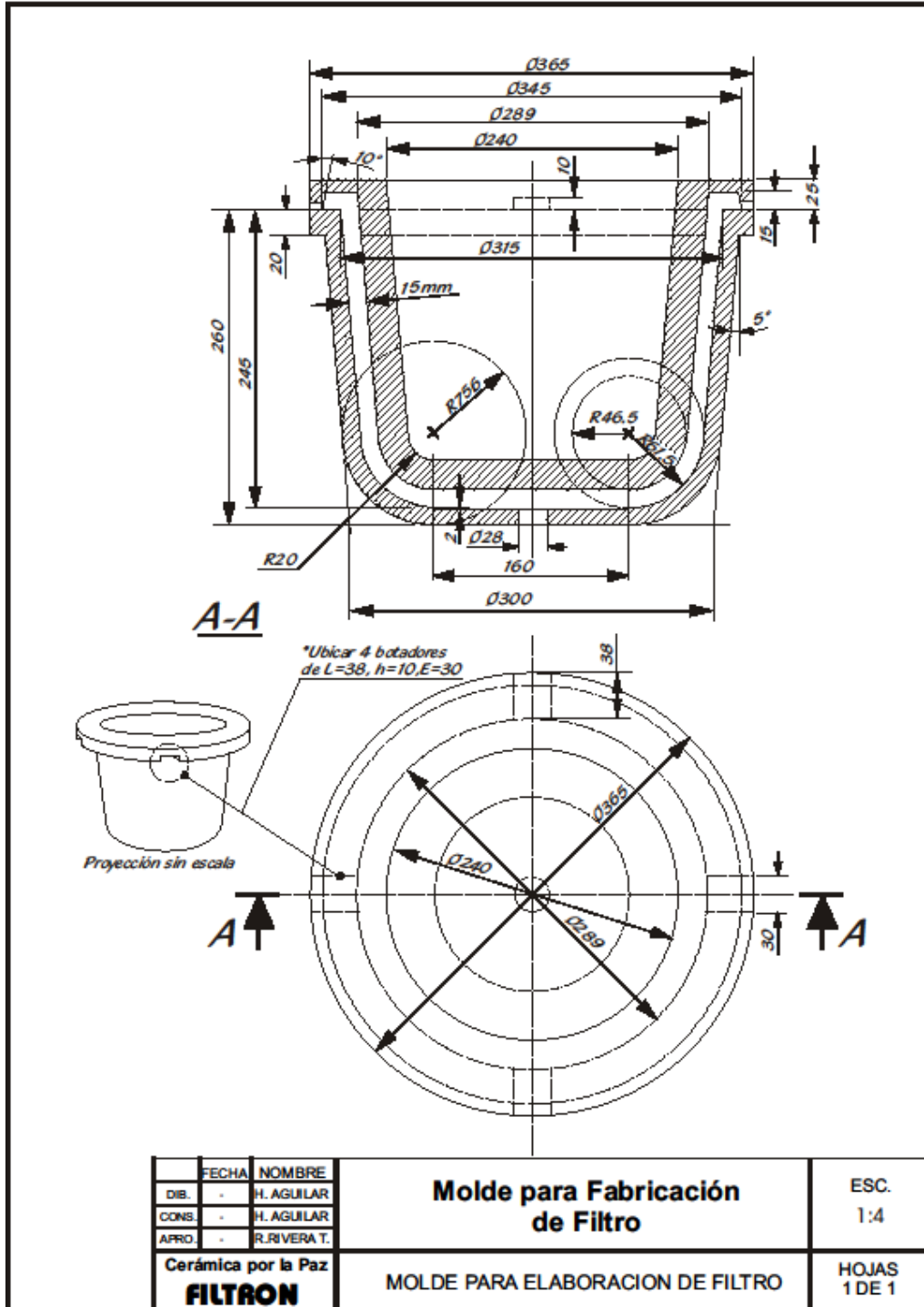

## I-4.2 How to Make a Cement Mold

To make a mold using cement, Manny Hernandez first makes a prototype filter on a pottery wheel. Once fired, this prototype will be used as the core to make the cement mold. Because the prototype will shrink during drying and firing, the shrinkage rates of the clay and filter mixture need to be calculated and added to the dimensions of the prototype filter design so the final filter will fit well in the receptacle. The prototype is formed to the required dimensions and then air-dried. After it has dried sufficiently it is fired in the kiln, usually with other items so as not to waste fuel.

Keep in mind that the mounting of the cement molds on the hydraulic filter press is opposite to the PFP press (Figure 5-6, Figure 5-7). In this press, the female mold is fixed at the top of the press with the opening facing down and the male mold is mounted face up on a frame table that slides out to clear the female mold. The male mold is mounted to a plywood base that can be adjusted in any direction to make sure it is centered with the female mold.

The fired prototype is used to make a cross-sectional drawing of the mold and a metal cage to fit around it. The cross-sectional drawing is made by clamping the rim of the prototype to a vertical surface. A piece of paper, such as craft paper, is placed on a horizontal surface below the prototype. Using a carpenter square, project the outline of the prototype on the paper by making dots about 1 to 1 ½ inches apart. After completing the outside profile, connect the dots. The next step is to draw the inside profile of the filter. Mark dots about 1 to 1 ½ inches apart and about ¾ of an inch from the outside profile, then, connect the dots. The inside profile of the filter is also the outside profile of the male mold.

The metal cage, which is made to fit loosely around the rim of the prototype, is used for reinforcement when cement is poured over it. The cage for the female mold is attached to a metal ring that is about 1/8 by 1 ½ inch wide flat stock which will act as a cutter to separate the excess clay from the pressed filter. The cage also has 4 bolts welded to the top ring for mounting to the horizontal "H" member that the female mold is attached to. The "H" member moves up and down within the vertical sides of the hydraulic press. A hand winch is attached to the side of the press frame and is used to raise and lower the female mold.

Two cones are used to retain the cement when it is poured to make the female mold. The two cone shapes, which were calculated on the cross-sectional drawing, are cut out of a piece of metal which is about as flexible and thick as aluminum flashing. One metal cone fits outside of the metal cage and the other fits around the metal ring and against the outer cone. The cone shaped metal form used to retain the cement from the outside is secured firmly with wire to hold it down, otherwise the pressure of the cement will raise the metal cone and all the cement will spill out (lesson learned). The prototype (core) retains the cement for the inside of the mold. Both the inside of the cone shaped metal forms and the prototype must be coated with Vaseline so that they can be easily separated.

A core is also set directly on the crowned top of the prototype to create a hole at the top of the mold. After the cement has hardened and the core is pulled out, the hole allows access to force the prototype filter out of the female mold. This is usually accomplished with a wooden dowel and a hammer.

Before the prototype is removed, the male mold is poured. The male mold is set up by attaching a board across the middle of the open end of the prototype. The board has two bolts set into it which will be used to attach the male mold to the moveable table mount. After the male mold is attached to the female mold, it is leveled with a bubble level or a spirit level. Apply Vaseline and pour the cement inside the prototype. When the male portion of the set

of molds is dry, the male mold can be removed from the inside of the prototype. Then the prototype can be removed from the female mold with the dowel and hammer. Both of the sheet metal cones can then be removed from the outside of the female mold. Any defects, such as air pockets, in either mold can be filled with plaster of Paris, then sanded.

## Annex J. Materials Suppliers

Whenever possible, materials should be sourced in country.

### J-1 Cones

Orton Cones can be purchased at: [www.ortonceramic.com](http://www.ortonceramic.com). Seger is another well known brand name for pyrometric cones. Large, self supporting, or small cones may be used; however, cone numbers are not standardized: different sized cones and cones from different manufacturers are designed to deform at different temperatures; therefore, manufacturer specifications should be checked.

### J-2 Pyrometers and Thermocouples

Pyrometers provide a measurement of the temperature inside the kiln. A thermocouple is a device inserted through the kiln wall which heats up inside the kiln; information is transmitted by wire to the pyrometer which reads the temperature of the tip of the thermocouple. A pyrometer with two inputs is recommended, as it can be used with two thermocouples to measure the temperatures at relatively higher and lower locations in the kiln, identifying the temperature differential between hot and cool spots. A single-input model will only measure the temperature from one thermocouple in one location, and thus is not helpful to bring a kiln to an even temperature distribution.

#### J-2.1 Pyrometers

- Fluke Double input, model #52-2 NIST:  
<http://www.grainger.com/Grainger/FLUKE-Hand-Held-Thermometer-4YV89>
- Fluke Single input, model #FLUKE 51 II (not recommended unless on a tight budget, it is US\$120 cheaper):  
<http://www.grainger.com/Grainger/FLUKE-Hand-Held-Thermometer-4YV88>
- EXTECH Double input, model #421502 (Probably the most cost effective for a factory without computer access, US\$90 cheaper than the Fluke single-input):  
<http://www.grainger.com/Grainger/EXTECH-Hand-Held-Thermometer-4PC60>
- Other more expensive models can be purchased at: [www.grainger.com](http://www.grainger.com); however, the models listed above are adequate.

Digital data loggers are a better deal. For about the same price as the Fluke single-input pyrometer, the Extech 3-input data logger has memory storage that can be programmed to log in temperature data at set time intervals. After the firing, the data can be transferred to a computer, and the firing curves will be automatically generated; these are used at Filtrón in Nicaragua.

- EXTECH, model # HD200 is recommended:  
<http://www.grainger.com/Grainger/EXTECH-Thermometer-IR-Thermometer-4TXH8>



EXTECH HD200  
Data logger

- Fluke, model # FLUKE 52 II, is more expensive, and has less memory storage:  
<http://www.grainger.com/Grainger/FLUKE-Hand-Held-Thermometer-4YV90>

### J-2.2 Thermocouples (Type K)

- Tempco, model # MTA00804:  
<http://www.grainger.com/Grainger/TEMPCO-General-Purpose-Thermocouple-5ZY12>
- Tempco, model # MTA01187:  
<http://www.grainger.com/Grainger/TEMPCO-Thermocouple-Probe-3AEY4>



Tempco MTA00804  
Thermocouple

## J-3 Silver Products

### J-3.1 Collargol

Laboratorios Argenol sells Collargol powdered colloidal silver as per specifications below. The current price is US\$ 806 for one kilogram. They also sell colloidal silver in liquid form with a 3.2% concentration. Their website address is: <http://www.laboratorios-argenol.com/quiensomosi.htm>

PRODUCT DATA SHEET	
PRODUCT	COLLOIDAL SILVER
PHARMACOPEA	French IX Edition
DETERMINATIONS	SPECIFICATIONS
CHARACTERISTICS	Grey to black-blue brilliant flakes or granulated powder. Almost odorless.
SOLUBILITY	Insoluble in alcohol and ether. Slowly soluble in water.
IDENTIFICATION	Corresponds
ASSAYS	
S Solution	Complete
Sol. Appearance	Corresponds
Alkalinity	$\geq 1,5$ ml NaOH 0,1 N
Silver Salt	No opalescence
SILVER CONTENT	70 - 75%
SYNONIMS	Collargol, Argentum Colloidale
USAGE	Strong antiseptic
STORAGE	In well closed containers, protected from Light
PHARMACOPEAS	French IX, Belgian, Swiss, Spanish, DAB-6, Russian

### **J-3.2 Ultra silver**

The 40,000 ppm (mg/L) Ultra Silver colloidal silver solution is not available to purchase online. Snow Fresh produces this solution for industrial purposes (personal communication with the manufacturer at 1-888-396-1893). The price is US\$100/quarter.

They claim the average particle size is 34-35 nm (similar in size as silver supplied by Argenol), though no documentation was provided. The process used to prepare the solution is using the electrochemical reduction of silver. After they produce the electrolysis a protein is added to stabilize the colloidal silver suspension.

### **J-4 Taps**

One recommended plastic tap manufacturer in the United States is Tomlinson Industries, available at [gstrunak@tomlinsonind.com](mailto:gstrunak@tomlinsonind.com).

RDI-C uses taps from a supplier in China: Ruxlin Manufacturing Model F20E1, this model is ceramic inside.

IDE purchases metal taps manufactured in Vietnam from Mr. Ly To Ha, House #493, St. Gla Phu, Quarter 3, District 6, Ho Chi Minh City, Vietnam. Telephone: 0938-168608

### **J-5 Water Quality Analysis**

#### **J-5.1 Microbiological Testing**

For information on microbiological testing, brands and suppliers, please refer to: *Microbiological Indicator Testing in Developing Countries: A Fact Sheet for the Field Practitioner* (contact: Daniele Lantagne at: [dlantagne@cdc.gov](mailto:dlantagne@cdc.gov)).

#### **J-5.2 Silver Testing**

Silver tests can be purchased from: <http://www.hach.com/>.

#### **J-5.3 Arsenic Testing**

Recommended field tests for arsenic in water:

- 1) HACH Arsenic Test Kit, Product # 2800000 available from: <http://www.hach.com/>
- 2) Arsenic Quick Test, model # 481396-2 by Industrial Test Systems available at: <http://filter.filtersfast.com/search?w=Arsenic+Test+Kit&submit1=Search>

Or, samples of raw or fired clay can be sent to Vinka Craver for testing at the following address: Vinka O. Craver, Assistant Professor, Department of Civil and Environmental Engineering, University of Rhode Island, Bliss Hall 213, Kingston, RI 02881. Phone (401) 874 2784; Fax (401) 874 2786. Fired clay and filter samples should be 20 cm x 20 cm and clearly labeled.



# Annex K. Sample Operation and Maintenance Instructions

**ARCIFILTR**  
AGUA SEGURA PARA BEBER

**1** Lavarse muy bien las manos.

**2** Lavar la tapa y el balde con agua clorada (o hervida) y jabón.

**3** lavar el filtro con un cepillo y enjuagar con agua desinfectada.  
**Ojo:** nunca lave el filtro con cloro ni jabón!

**4** Colocar el filtro encima del balde.

**5** Llenar el balde pasando el agua por un paño limpio. (retirarlo al terminar).

**6** Poner la tapa, (mantener siempre lleno y tapado).

**7** lavar manos y grifos con jabón y agua limpia antes de servir el agua.

**Cruz Roja Colombiana**

**Oxfam**

**unicef**

**FUNDACIÓN CREDISERV**  
Ocaña N.S.

Fabricado por:  
**ASOPAFIN**  
Vereda el Haniño - Parcela 9 32  
Telefax (7) 5698004  
E-mail: asopafin@hotmail.com  
www.asopafin.es.tl  
Ocaña N. de S.

Fecha de entrega:

K-1 Cleaning Instructions, Colombia  
(Asopafin 2009)

## HOW TO USE YOUR FILTRON

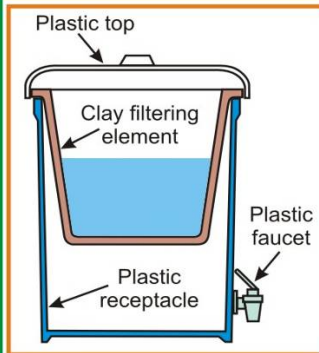

### 1. Washing the RECEPTACLE

Wash your hands with soap .  
 Attach the spigot (faucet) to the plastic receptacle.  
 Fill the receptacle one quarter full with water and add two tablespoons of chlorine bleach.  
 Leave this for thirty minutes to disinfect the plastic receptacle.  
 Use this water to wash the entire inside of the plastic receptacle and the lid with a brush or cloth.  
 Drain the water out through the spigot to disinfect.  
 If you do not have bleach, wash the receptacle and lid with soap and water as described above.  
 You can use either filtered or boiled water to rinse.



2) Place the plastic receptacle in a location that is stable and out of the way of activity.

Using both hands on the edge of the clay filter, place it on the mouth of the receptacle.



3) To get rid of the clay taste of the new filter, fill it with water and drain through the spigot. Repeat until all taste is gone.

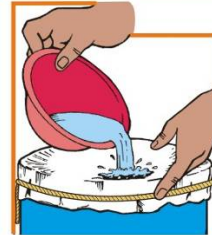

4) If your water is turbid, strain it through a clean piece of fine cloth. Tie the cloth in place around the outside of the plastic receptacle.



5) Keep your filter filled and covered at all times.

The filter will flow more rapidly (one to two liters per hour) if it is kept full.  
 Remember: Before serving water wash your hands and cups with soap.

## HOW TO CLEAN YOUR FILTRON



### Cleaning your CLAY FILTER

1) When the flow rate decreases, it is a signal that the pores of the clay filter are clogged.

To wash:

- Do not lift the clay filter when it is full of water. Wait until the clay filter is empty and there is filtered water in the plastic receptacle.
- Wash your hands with soap.
- Remove the clay filter from the plastic receptacle and put it on a plate that has been washed with filtered water.



- Pour a few inches of filtered water back into the filter.
- Scrub the filter with a stiff laundry brush on the inside and outside to remove any debris or particles.
- Do not worry if some of the clay comes off. It means you are scrubbing well.
- Rinse with filtered water until the water is clear.

**Attention! Never use chlorinated water or soap to wash the clay filter.**



### 3) Washing the PLASTIC RECEPTACLE

Wash the plastic receptacle each month with chlorinated water or with soap as explained in part 1. Once you have finished washing, return the clay filter to the plastic receptacle to begin use.

**Attention: The Filtron filter generally functions well for a year and a half or more. If you have problems, contact the organization that distributed your filter for advice on what to do.**

 <p><b>Address:</b> Prek Tom village, Kbal Kos commune, Kean Svay district Kandal Province. Tel:(855) 24 399 577</p> <p>www.rdic.org Email: rdibus@rdic.org</p> <p><b>1-Filter is Fragile</b></p> <ul style="list-style-type: none"> <li>• Handle with care.</li> <li>• Do not clean the filter with soap water.</li> <li>• Do not touch interior and exterior surface of the filter.</li> <li>• Only handle the filter from the rim.</li> <li>• Do not poke your finger in the faucet hole.</li> </ul>	<p><b>2-Cleaning</b></p> <ul style="list-style-type: none"> <li>• Take the filter out it and place in a clean area.</li> <li>• Clean the filter with water that has been filtered or boiled.</li> <li>• Clean the water bucket (not the filter it self) with soap and water then allow the bucket to air dry.</li> </ul> <p><b>4-How to assemble Faucet</b></p> <ol style="list-style-type: none"> <li>1 Faucet.</li> <li>2 Washer inside the filter bucket.</li> <li>3 Fastening nut.</li> </ol>	<p><b>4-Daily Usage</b></p> <ul style="list-style-type: none"> <li>• Assemble the filter as shown.</li> <li>• Cover with lid to prevent dust and insects.</li> <li>• Place it in a clean and safe area.</li> </ul> <p><b>Note:</b></p> <ul style="list-style-type: none"> <li>- The filter lasts for 2 years. After 2 years replace it with a new.</li> <li>- The filter can be used to filter any kind of water, such as pond, river, stream, water fall, etc.</li> <li>- For more information please contact us at the address provided below:</li> </ul> <p>Office Phone: (855) 24 399 577 Website: www.rdic.org Email: rdibus@rdic.org</p>
--	---	--

**K-3 Operation and Maintenance Instructions, RDI-C**  
(Hagan et al. 2009)