

# Zimbabwe's user-friendly Bush Pump

by Peter Morgan

The Zimbabwe Bush Pump last featured in *Waterlines* in October 1989 (Vol.8, No.2). Already described by more than one commentator as 'a remarkable pump', a great deal of research and development has been carried out over the last six years. What are the results?

THE BUSH PUMP has been Zimbabwe's national handpump for over sixty years, and remains the pump of choice for all community settings in rural areas. The pumphead was first designed in 1933 by Tommy Murgatroyd in Matabeleland, western Zimbabwe. Since then it has undergone many refinements and, since 1989, the 'B' type Bush Pump has been the national standard model. All the pump's components are manufactured locally, and this means that spare parts are also available. Over 11 000 'B' type pumpheads have been locally manufactured to date, and the total number of pumps installed in the country amounts to about 25 000. This includes a few of Murgatroyd's original 1930s pumps.

Currently, the District Development Fund (DDF) — an arm of government within the Ministry of Local Government — is responsible for maintaining the pump. The DDF supervises 'pump minders' who operate at ward level, and 'pump caretakers' operating at the pump site itself. In recent years, the move has been towards involving local communities in maintaining the pump. This community involvement is currently a case of assisting the pump minders in their duties, but the government is anxious to increase the role of the users even further, especially for routine maintenance procedures.

## The standard Bush Pump

Bush Pumps are designed to be robust: they are made from steel, and use a hardwood block as a lever and bearing surface. The wooden blocks are made from mopane or teak, and last for 20 years. They are boiled in oil to provide self-lubricating properties. The handle is made of steel pipe, 2.5m long and 40mm and 50mm wide. This diameter and length suit the lifting requirement from just a few, to over 80m. Down-the-hole components are made of brass and steel and — like the pumphead — are well tested. Most pumps use 75mm-diameter brass cylinders

attached to 50mm nominal bore galvanized-iron rising main; pump rods are usually 16mm mild steel.

In its standard form, the 'down-the-hole' components of the Bush Pump are not easy to maintain. A seal replacement, for example, the most commonly replaced component, necessitates the removal of all rods and pipes to gain access to the piston. This is a heavy job, requiring specialized lifting tools and trained labour, and is certainly not an easy task for villagers to undertake.

## Making things easier

Most research developments in recent years, therefore, have focused on the down-the-hole components, especially those which make routine maintenance far easier. These have concentrated on the use of 'open-top' 50mm cylinders, used in combination with the standard pumphead. Open-top cylinders permit the extraction of the piston and its seal through the 50mm steel pipe, without the necessity for lifting the heavy pipes; this simple change reduces the complexity of routinely replacing the piston seal.

## 'Down-the hole' components

The cylinder is a 600mm long, 50mm-internal diameter brass tube with a wall thickness of 3mm. The upper and lower ends are expanded and processed with BSP threads. The lower end of the

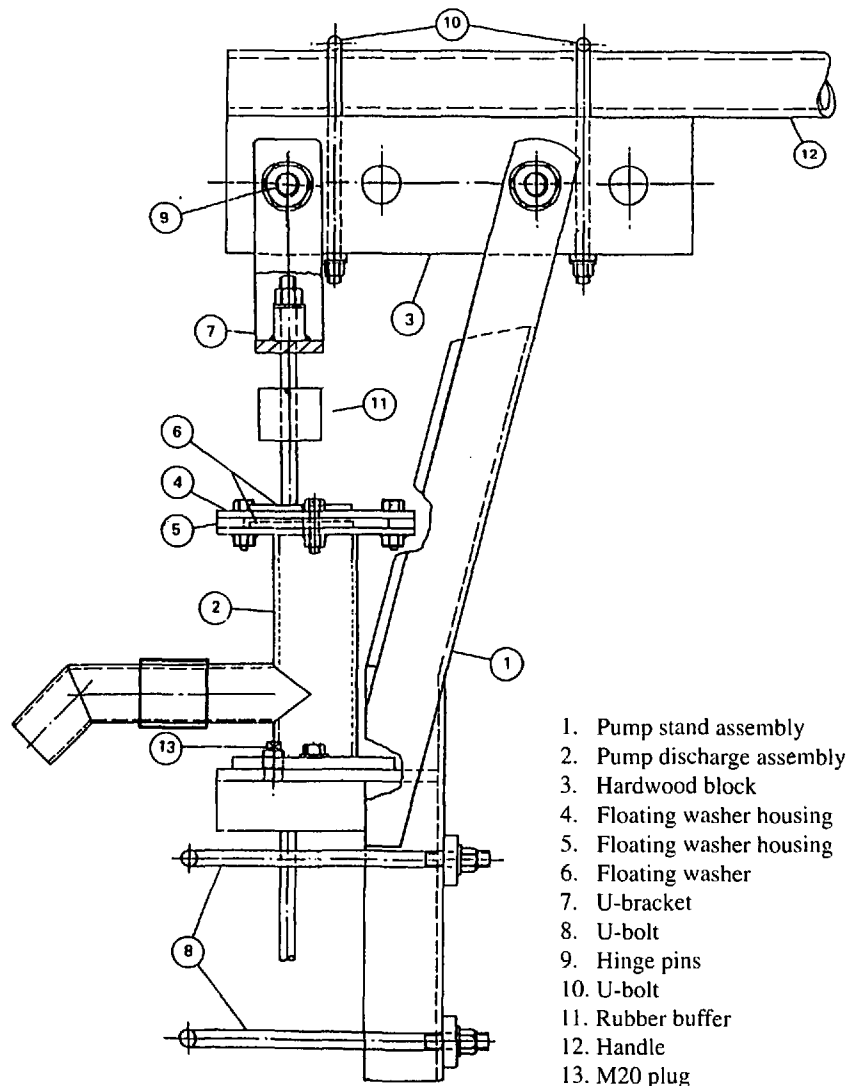

Figure 1. The 'B' type Bush Pumphead and all its parts.

cylinder is fitted to a reliable, heavy-duty brass footvalve, while the upper end is fitted to a standard BSP steel socket, which is itself attached to the lower end of the rising main.

The **rising main** is standard 50mm nominal bore galvanized-iron piping, with the internal surface cleaned out to provide an internal diameter of 53mm+. Trials are also being undertaken with 65mm brass cylinders and steel rising main. Although the weight is heavier, and the costs higher, the extra water flow, which rises from 20l/m to 30l/m is thought, in some cases, to be desirable.

The **piston** is made of brass, and is cast and milled in one piece. It uses the same nitrile rubber seal and rubber poppet valve developed for the 'Afridev' handpump. The upper end of the piston is threaded internally, and a 3-metre length of 16mm-diameter galvanized-steel rod is threaded into the piston body. It is held firmly in position with a locknut and brass pin. The outer diameter of a new piston seal attached to the piston assembly is 51mm.

The **pump rods** are made in 3-metre lengths, and are either 12mm or 16mm in diameter. 16mm rods are galvanized, whilst the lighter 12mm rods — which become weaker more rapidly in aggressive waters — are coated with Copon EP 2300 (or Copon K.S.16.W), a specialized epoxy resin which protects the rod.

The **rods** (both 12mm and 16mm)



Peter Morgan

*The Bush Pump undergoing trials at Idaho Farm in Norton, Zimbabwe.*

are connected with case-hardened steel hooks and eyes which are fabricated in bright mild steel. The hooks and eyes are processed separately, being threaded internally before they are case-hardened. Each rod is fitted with a hook at one end and an eye at the other, the eye being at the upper end of each rod. The hooks and eyes are threaded and welded to each rod in the factory. The rods hang down under their own weight and little slack develops during the operation of the pump.

Some experimentation is still being undertaken to determine the best rod diameter for different depths. 16mm rods are stronger, and have been the

standard for many years, but they are also heavy and difficult to lift out by hand in pumps set to 35m or more. The lighter 12mm rods now on trial will probably replace the 16mm rods as confidence in them grows. Technically, it would be possible to attach the hooks and eyes to any rod, including 10mm stainless steel but, so far, this combination has not been tried.

## Pump testing

The 'extractable' system described above has been tested under field conditions since April 1991. For the first two years, mild-steel hooks and eyes were tested, followed by a further 18 months with case-hardened hooks and eyes. Currently, about 40 extractable pumps are on trial in Zimbabwe, and a great deal of information has already been collected from these units. The results below indicate the measurements of wear on the parts.

**Wear on hooks and eyes** Researchers have paid particular attention to the measurements of the vertical member of the hook (see photo) which is the most vulnerable part of the pumping system. Undue wear on this portion of the eyes can cause the joint to collapse; this happened with early mild-steel (unhardened) joints when, after 14 months of wear, 4.8mm of the total diameter of 15.3mm of the hook diameter was lost (rate of wear = 4.11mm/year). The case-hardening process of the hook and eye joint greatly reduces this rate of wear at the vital part of the hook to 0.145mm/year (mean of eight joints on longest-serving and hardest-working test pump over 17 months). At this rate of wear, a standard case-hardened hook and eye joint is expected to last at least five years, possibly 10, before it has to be

Peter Morgan



*The brass piston assembly showing rubber poppet valve and seal in place.*

*Close-up of hook-and-eye rod joint after 18 months' operating in aggressive water conditions at Idaho Farm.*



Peter Morgan

replaced.

Wear on the eye is greater than the hook (mean of 0.30mm/year as measured on longest-serving and hardest-working test pump). Wear on the eye is less critical, however, as the opening of this component is supported on both sides. Wear on the horizontal faces of the joint — where the hooks and eyes touch — is small, and is not regarded as a critical point of wear. Measurements made on other trial pumps for the hook and eye joints are less than those indicated above.

**Wear on steel rising main** Wear on the internal surface of the steel rising main has also been measured over a 20-month test period. The results of this test revealed a rate of wear of only 0.06mm/year of the 3.5mm total wall thickness. Such a rate of wear would not influence the overall length of the life of the pipe.

**Wear on piston seal and poppet valve** These two components are used in the Afridev handpump. The nitrile rubber seal is flexible, and can easily be attached to the solid piston (i.e. one that does not unscrew). Seal life varies somewhat, depending on the smoothness of the internal wall of the cylinder, the quality of the water, and the amount of pump use. Most seals last for at least six months, and a period of between six months and one year seems to be the normal range of life expectancy. One year for a component which is easily replaced seems reasonable. Wear on the poppet valve is negligible, and very few of these components have been replaced in the trials.

## Maintenance

When the water output of the pump is reduced, the time has come to replace the seal:

1. The two main head bolts holding the wooden block, and the three bolts retaining the 'floating-washer' assembly are removed with two spanners.
2. The uppermost rod is withdrawn (with U bracket, rubber buffer and two floating washers).
3. The rods are now lifted by hand, one by one, and held up at each joint by a simple rod-holding tool (see photo above), whilst the joints are disconnected. The hooks and eyes disconnect easily once the hook has been moved to one side. A 30-metre string of rods can be removed in little more than five minutes by a trained team and, possibly, in 10 minutes by a less-experienced team.



Peter Morgan

*The 16mm rods are lifted one by one — stage 3 of replacing the seal.*

4. The worn seal is replaced by hand using a small screwdriver. All the components are then replaced in

### Costs

In December 1994 the pumphead cost Z\$122.90 (£9), with 50mm galvanized pipe costing Z\$61.48 per metre (£4.50) and 16mm rod at Z\$62.50 per 3-metre length (fitted with hooks and eyes). The combined costs of the 50mm open-top cylinder, piston, and footvalve is Z\$650 (£47.55). Tools (two spanners) cost Z\$73.25. In Zimbabwe, all these costs are increased by a 10 per cent local sales tax, taking the total cost of a 30-metre pump, supplied with spanners, to Z\$4747.10 (£347.26).

reverse order. The procedure is simple enough and the rod-holding tool acts as a safety measure, allowing less well-trained personnel to rest and reflect on their operation. A rod-extraction tool has also been designed to remove rods which are lost down the pipe.

Simple tools (including a few piston seals) must be kept with each pump. In practice, these are held by the pump minder where pumps of this type have been fitted. A full set of manuals has been produced for the pump.<sup>1</sup>

## Acceptance

The extractable version of the Bush Pump was officially endorsed by the National Action Committee (NAC) of the Zimbabwean Government in

November 1994 and, as a result, it will be used more and more in the country's handpump programmes. The introduction of the pump is seen as providing an ideal opportunity for the Government to disseminate more widely the concept of increased community management of the handpump programme.

At first, some communities tend to view the pump with scepticism. When a community pump is 'converted' from an existing standard model to an 'extractable' model, there is a considerable reduction in water output. At their peak, 75mm cylinders can deliver 40 litres of water per minute, whereas the 50mm extractable system only delivers about half this amount. Initially, this can deter the users, but the advantages soon become apparent when the replacement of a seal is to be undertaken by the pump minder with community assistance. DDF staff are far more receptive, as conversion makes their own working lives easier.



*Final assembly of the pump after the 'down the hole' parts have been inspected. The whole operation of lifting the rods, inspecting and replacing the seals, and reassembly takes less than 20 minutes on a 30m-deep pump.*

### Longer-term maintenance

Some local communities have already shown that they can manage routine maintenance alone, provided they have the seals and tools. In Zimbabwe, the concept of 'Community-Based Maintenance,' or 'Community-Assisted Maintenance' (CAM) is still in its infancy, and much has still to be learned.

Whilst the simple procedure of replacing seals and tightening bolts may suffice for several years, there will come a time when more costly parts of the pump will need to be replaced. Pump rods and piping, and even the pumphead itself, wear away over the years, and need either total replacement or, in the case of the pumphead,

refurbishment — at the very least. At the time of writing, the life expectancy of the rod system is between five and 10 years; the piping should last for approximately 10 years. Foot-valves are known to last at least this long and, since the cylinder is a simple brass tube, it may last longer than 10 years.

The cost of replacing these parts must be met if the pump is expected to provide a long-term service extending over decades. At the present time, the funds provided by the Government through the DDF are insufficient to keep the national fleet of pumps in full working condition. When a pump becomes old and is in need of a substantial refit, it is often replaced completely as part of a donor-funded pump-rehabilitation programme.

### Time will tell

Ideally, the refurbishment of older pumps and the replacement of old parts should be undertaken as part of a locally funded, recurrent maintenance and rehabilitation programme, and should not depend on donor support. Such funding should be provided either by the Government itself, or by the users in some way. This is an area in which Zimbabwe still has a long way to go.

The introduction of this new Bush Pump model in Zimbabwe is in keeping with international trends to make handpumps 'user friendly', with a bias towards village-level maintenance. Whilst pumps of this type will be serviced by the DDF for some years to come, in Zimbabwe the experience of the next few years will determine whether the pump can be routinely maintained with village inputs alone, and whether the pump can keep abreast of international standards of pump design and performance.

### Acknowledgements

Many people and organizations have contributed to the recent development of the Bush Pump. The Zimbabwe Government has encouraged continued development through the Technical Sub-Committee of the NAC which oversees water and sanitation activities within Zimbabwe's rural areas.

Particular thanks to Erwin Von Elling who has been at the forefront of Bush Pump manufacture, and who has fabricated all the specialized parts described in this article. The field team, led by Ephraim Chimbunde, has played a crucial role in training, and in demonstrating the pump throughout the country. Special thanks also to George Nhunhama of the National Co-ordination Unit, and to Raston Muzamhindo and other DDF staff. Anthony Waterkeyn, the Director of the Mvuramanzi Trust, has given his wholehearted support.

Several organizations have contributed to the development of the Pump. UNICEF purchased the first ten 'B' type pumps for trials in 1987, and SIDA has supported the development of the pump since 1990. WaterAid, the ODA, and the Oak Foundation have willingly included experimental pumps in their development programmes. To all these organizations and individuals I pass on my thanks for keeping our Zimbabwean technology alive.

### References

1. *A manual for the installation, dismantling, and maintenance of the 'B' type Bush Pump. Vol. I: The 50mm extractable piston model; and Vol. II: The 75mm model non-extractable piston model*, Mvuramanzi Trust, Harare, 1995. A limited number of free copies are available.

*Peter Morgan is Chairman of the Mvuramanzi Trust. Contact the Trust at: 215 Second Street Ext./Cnr. Lomagundi Road, Avondale, Harare, Zimbabwe. Tel/Fax: +263 4 335172.*